

The Significance of Cultural Risks for Western Consultants Executing Gulf Cooperation Council Megaprojects

Alan Walsh, Peter Walker

Abstract—Differences in commercial, professional and personal cultural traditions between western consultants and project sponsors in the Gulf Cooperation Council (GCC) region are potentially significant in the workplace, and this can impact on project outcomes. These cultural differences can, for example, result in conflict amongst senior managers, which can negatively impact the megaproject. New entrants to the GCC often experience ‘culture shock’ as they attempt to integrate into their unfamiliar environments. Megaprojects are unique ventures with individual project characteristics, which need to be considered when managing their associated risks. Megaproject research to date has mostly ignored the significance of the absence of cultural congruence in the GCC, which is surprising considering that there are large volumes of megaprojects in various stages of construction in the GCC. An initial step to dealing with cultural issues is to acknowledge culture as a significant risk factor (SRF). This paper seeks to understand the criticality for western consultants to address these risks. It considers the cultural barriers that exist between GCC sponsors and western consultants and examines the cultural distance between the key actors. Initial findings suggest the presence to a certain extent of ethnocentricity. Other cultural clashes arise out of a lack of appreciation of the customs, practices and traditions of ‘the Other’, such as the need for avoiding public humiliation and the hierarchal significance rankings. The concept and significance of cultural shock as part of the integration process for new arrivals are considered. Culture shock describes the state of anxiety and frustration resulting from the immersion in a culture distinctly different from one's own. There are potentially substantial project risks associated with underestimating the process of cultural integration. This paper examines two distinct but intertwined issues: the societal and professional culture differences associated with expatriate assignments. A case study examines the cultural congruences between GCC sponsors and American, British and German consultants, over a ten-year cycle. This provides indicators as to which nationalities encountered the most profound cultural issues and the nature of these. GCC megaprojects are typically intensive fast track demanding ventures, where consultant turnover is high. The study finds that building trust-filled relationships is key to successful project team integration and therefore, to successful megaproject execution. Findings indicate that both professional and social inclusion processes have steep learning curves. Traditional risk management practice is to approach any uncertainty in a structured way to mitigate the potential impact on project outcomes. This research highlights cultural risk as a significant factor in the management of GCC megaprojects. These risks arising from high staff turnover typically include loss of project knowledge, delays to the project, cost and disruption in replacing staff. This paper calls for cultural risk to be recognised as an SRF, as the first step to developing risk management strategies, and to reduce staff turnover for western consultants in GCC megaprojects.

Alan Walsh is with the University of Salford, Qatar (e-mail: alanwalsh1@hotmail.com).

Keywords—Western consultants in megaprojects, national culture impacts on GCC Megaprojects, significant risk factors in megaprojects, professional culture in megaprojects.

I. INTRODUCTION

THIS paper discusses the implications of a recent case study which examined the impacts of cultural dissonance associated with high staff turnover of western consultants executing GCC megaprojects. For this research, western consultants include nations within an Anglo cluster, which includes Australia, Canada, England, New Zealand, South Africa and the USA [1]. They are also referred to as an English speaking cluster [2]. Before examining the findings of the case study, this paper contextualises megaprojects, and their characteristics, in particular their known high level of risk. Western consultants are engaged for their expert professional knowledge in construction management, and the impact of professional culture and associated belief systems is considered. The paper contextualises national culture and reviews the complexities of measuring culture. The paper examines to what degree culture is a risk for megaprojects and considers whether this risk is particularly significant in the execution of GCC megaprojects, which are heavily reliant on western consultants. The case study methodology, analysis and findings are reviewed and interpreted, and the experience of different nations with cultural dissonance is considered.

II. RISK AS A MEGAPROJECT CHARACTERISTIC

Megaprojects were initially considered as projects with a construction value greater than \$1 billion [3]. This financial benchmark has been updated in the search for a definition more suited to the complex combination of characteristics of megaprojects. Researchers typically identify critical components such as the large-scale of mega-projects; the technical and management complexity; the long timescales required to design, develop and build; the involvement of multiple public and private stakeholders; and their transformational nature. Recent work has examined the degree to which megaprojects are risk-filled ventures that can impact millions of people [4]-[8]. Despite megaprojects being generally unique, the criticality of sub-components varies according to its specific nature. Risks are defined by the Project Management Institute as ‘an uncertain event or condition that, if it occurs, has a positive or negative effect on one or more project objectives’ [9]. This paper considers Significant Risk Factors (SRF) as those containing extensive

risk and subsequently, a high impact on the successful execution of megaprojects. The high level of risk associated with megaprojects is well publicised and successful completion has been labelled as improbable with successful completion considered as 'An Anatomy of Ambition' [2]. Risks that have been identified include financial and programme risk, political risk, social risk, stakeholders risk, cultural risk, design risks and overall feasibility risks [10]-[13]. This paper focuses on cultural risk, which can lead to cultural dissonance. Experience suggests that this risk is often overlooked or given little or no consideration until it becomes a factor too late to address.

III. CULTURE AS A RISK FACTOR

Research concerning the influences of cultural dissonance on the execution of megaprojects has tended to focus on European and American megaprojects, such as the Panama Canal and the Channel Tunnel [14], [10], [15]. These studies identify the severe nature of cultural risks in megaprojects and research examining the most common causes of megaproject failures suggests that culture is a risk that should be considered within 'all future megaprojects' [16]. Despite this, there is little research to date, which explores the execution of the 300 plus megaprojects in the GCC. Multi-cultural megaprojects are common in the GCC due to local skills shortages and high capital expenditure on megaprojects [17]. This results in the GCC importing construction expertise to manage the execution of these works. This execution team comprises of a multicultural workforce, from an extensive gathering of culturally diverse hired in experts from a pool of highly qualified resources from across the globe [18]-[20]. This research finds that the impacts of cultural dissonance are a Significant Risk Factor for GCC megaprojects and identifies that the higher the cultural distance between the nations, the more likely and damaging the potential conflict.

Professional Culture

Professional culture is described as a distinction between loyalty to the employing organisation versus commitment to the industry [21]. Western consultants are engaged in the GCC to follow professional guidelines while providing expert knowledge and advice. Despite some criticisms of the standards of professionalism in the industry [22]-[24], a professional culture is extensively promoted by construction industry institutions such as the RICS, CIOB and RIBA. These bodies have aspired to set universal standards and practices amongst construction professionals. Those entering the GCC market are typically required to be members of these bodies, in addition to passing local examinations and providing attested evidence of educational qualifications. The sponsor not unreasonably expects that the hired professional consultants are familiar with their field of engagement, appropriately trained, professionally accredited, subject to some form of governance, and adhere to ethical standards [23].

Consultancy services have become more global and are influenced by cultural transformations associated with

migration, immigration and acculturalisation. Research points to cultural attitudes changing across generations with the impact of global communications, cheaper modes of travel and better standards of education [25]. Historically, the physical location of a company's headquarters had a considerable influence on its culture (this was particularly the case for famous American brands such as Apple or MacDonalds [26]). It is now common for organisations to adopt a *healthy dose of particularism* as they enter new markets [27]. Initial research with western professional consultancy firms suggests that they have only made minor changes to their head office policies, mostly to suit local legislation and regulations governing construction standards, holiday benefits and working hours.

National Culture

This paper considers culture at a national level. Researchers describe national culture as an entire nations group collective experiences, society rules, and norms or *mental software for the mind* [28]-[30]. National culture helps distinguishes the people of one country from those of another [31]. Culture is often reported as a dynamic phenomenon [32], [33], which may not be evident unless the participant physically experiences it [34], [35], [25]. To measure and compare different nations, researchers typically provide a numeric value for standard components they have identified within a culture, such as freedom of expression or independence. They often label these components as *dimensions, values or orientations* [36], [37]. The sum of these dimensions, values or characteristics, then forms a national outlook or a notional 'national culture'. This numeric value provides a tool for comparing different nations. Work in this area is both prolific and contested: researchers have identified more than 180 measurement tools, each claiming to accurately 'measure the culture' of a country [38].

Cultural Measurement

Hofstede, a social psychologist from the Netherlands, is credited with producing a research framework which examines or predicts social behaviours and norms [36]. His popular framework for measuring national culture [38]-[40], has received over 50,000 citations [41], [42]. It is even suggested that 97.5% of all culture measurement models have traces of his original framework [38]. There are significant debates as to the validity of his framework. Researchers debate whether his findings are valid today [43]-[45], and many vigorously contest the reliability of his recorded data. Criticisms include an acceptance of country-level validity, but a rejection of the suggested values [46]-[48]. Some cross-cultural researchers challenge Hofstede's framework for its lack of replication or consistency [49]-[52], or for its inability to be used as a predictive tool [49], [53], [54].

This paper does not seek to validate or question these divergent research findings. For this paper, a more pragmatic stance is adopted. Such cultural frameworks, as provided by Hofstede and others, reinforce the concept that individuals within different nations can be expected to behave predictably and consistently. Differences in outlook, behaviour and

attitude are in this context referred to as the cultural distance between nationals. The application of Hofstede's model in this paper serves to demonstrate the potential effects of expected cultural gaps between members of different nations working together on the execution of a megaproject. We neither seek to endorse or reject Hofstede's framework; the framework is, however, helpful at a practical and applied level in providing and defining and six cultural dimensions as given in Table I. It is these that we use as a framework for examining cultural dissonance as a risk factor.

TABLE I
 HOFSTEDE'S CULTURAL DIMENSIONS [84]

<p>1. Power Distance (high versus low) The extent to which the less powerful members of a society accept that power is distributed unequally.</p> <p>2. Individualism (Individualist versus Collectivist) Collectivism: people belong to in-groups (families, organisations, etc.) who look after them in exchange for loyalty. Individualism: people only look after themselves and their immediate family.</p> <p>3. Masculinity (high versus low) Masculinity: the dominant values in society are achievement and success. Femininity: the dominant values in society are caring for others and quality of life.</p>	<p>4. Uncertainty Avoidance (high versus low) The extent to which people feel threatened by uncertainty and ambiguity and try to avoid such situations.</p> <p>5. Long Term Orientation (long term versus short term orientation) The extent to which people show a pragmatic or future-oriented perspective rather than a normative or short-term point of view.</p> <p>6. Indulgence (Indulgence versus Restraint) The extent to which people try to control their desires and impulses. Relatively weak control is called "Indulgence", and relatively strong control is called "Restraint".</p>
---	---

Cultural Distance

Hofstede originally defined four dimensions [31], adding

TABLE III
 CULTURAL DISTANCES BETWEEN THE GCC AND CASE STUDY NATIONALITIES

Country	Power Distance Gap	Uncertainty Avoidance Gap	Individualism /Collectivism Gap	Masculinity/Femininity Gap	Nationals Engaged	Impacted by Culture
Australia	44	17	52	-8	2	2
Great Britain	45	33	51	-13	30	16
Canada	41	20	42	-1	3	2
New Zealand	58	19	41	-5	3	3
South Africa	31	19	27	-10	3	3
United States	40	22	53	-9	7	5
Others					16	9
Arab Countries	80	68	38	53	64	40

Cultural Integration

When a professional consultant takes up an appointment in another culture, a process referred to as cultural integration follows. When the individual enters a society where the cultural attributes are distant from their personal experiences, they frequently experience 'culture shock' [57]. This is described as an uneasy feeling in which *precious values and unshakeable core beliefs take a battering when we venture abroad* [58]. Hofstede describes the process as the visitor in a foreign culture returning to the mental state of an infant, in which the most straightforward things must be learned over again. This experience usually leads to feelings of distress, of

the dimension Indulgence [55] and completed the current schedule by including the dimension labelled as Long term orientation [56]. Only the first four original dimensions captured data for Arab nations and are used as a comparative measure in considering the cultural distance between the GCC and other countries. By examining the differentials between dimensional scores for different nations, cultural distance can be anticipated between the countries. The larger the delta in the scoring, then the more significant the culture gaps between the nations.

TABLE II
 SCORES FOR REGIONS OF THE FIVE MOST FREQUENT NATIONALITIES IN THE CASE STUDY

Country	Power Distance	Uncertainty Avoidance	Individualism /Collectivism	Masculinity /Femininity
	Index	Index	Index	Index
Canada	39	48	80	52
Great Britain	35	35	89	66
New Zealand	22	49	79	58
South Africa	49	49	65	63
United States	40	46	91	62
Arab Countries	80	68	38	53

Table II represents the dimensional scores for the nations with the most significant representations amongst the combined western consultants (Fig. 5). Table III highlights the cultural distance between these nations and those of GCC nations forming part of the Arab countries groupset. The higher the gap, the greater the cultural distance for the relevant dimensions.

helplessness, and of hostility toward the new environment [59]. Personal inherent cultural bias and ethnocentricity are often in conflict with aspirations towards cultural integration.

Research suggests that people possess an ingrained prejudice, as consciously or unconsciously, they may be biased as a result of their individual cultural experiences [31]. This includes an attitude towards 'other' cultures [60], which may delay or frustrate the integration process, and this has its roots in ethnocentricity. This is regarded as a common cause of cultural tension [40], [61]. Research refers to historic cultural legacies and feelings of superiority sometimes exhibited by geographical dominance of American, British,

French and Spanish conquerors, enforcing the conquerors' culture on the incumbents [58]. Current research [62] theorises that there is a current trend of cultural backlash against some of the 'other' cultures. They suggest that some racist phobias are reemerging, in response to impending wars and influences of economic deprivation and large influxes of migrants. There are between four and nine steps associated with the cultural integration according to the level of detail recognised [63], [64]. A four-stage approach is common. A conventional four-stage approach is shown in Fig. 1.

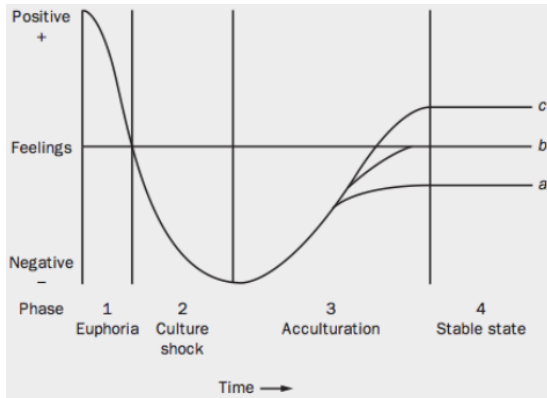

Fig. 1 Cultural Integration from Hofstede's "Exploring Cultures" [29]

In Hofstede's portrayal of cultural shock, he describes the initial journey is a feeling of euphoria, 'a honeymoon, filled with the excitement of travelling to a new land'; then culture shock occurs when real life starts in the new environment. Acculturation follows as the outsider slowly learns to function in the new environment, accepting some of the local values, and integrates (with varying success) into a new social network. He describes the final integration as a stable state of mind [29].

There are two sides to engaging with a nation. There are social integration and professional integration experiences. Those who emigrate in search of work, whether motivated by a desire for wealth or the necessity of employment, are obliged to integrate to these social and professional norms. Researchers have suggested that 10-20% of Americans return from the Middle East early due to job dissatisfaction or culture shock [65]. It is suggested that the costs incurred range from \$50,000 to \$1,000,000 for every premature exit [66], [67]. There is a wide range of financial costs dependent on the professional consultants' experience, making a universal assessment of costs hard to predict. However, this calculation does not attempt to quantify the intangible costs associated with the early departure of key personnel. This study has found significant project impacts, including disruption of management, lower staff morale, loss of momentum on the project, and loss of reputation.

IV. A GCC MEGAPROJECT PILOT CASE STUDY

Field-based research was conducted on a representative GCC megaproject, based in Qatar for a \$40 billion infrastructure megaproject, to investigate this phenomenon.

The case study focused on the three principal construction management consultants overseeing the execution of a megaproject in Qatar. The western consultants were headquartered in Germany, the United States and the UK. The churn rate of senior western consultants was monitored, and the positions tracked with the position turnover indicated on a programme. Analysis of this programme identified the turnover for each consultancy position, showing both the tenure of that position and the number of times the same position was filled. In terms of overall posts, the sponsor had approved 28 senior positions. This case study considered the most senior positions within these organisations. This purposeful restriction applied 28 jobs out of 733 personnel, as they were the consultant's representatives who directly engaged regularly (mostly daily) with the sponsor. There were 64 individuals (75 positions including internal promotions) involved in filling these 28 positions, and the findings indicated that 11 individuals held more than one position at various stages in the six-year review period, due to either internal transfers or promotions within this group. The pilot study investigated the factors which influenced this turnover (total position turnover is 75).

Initially, the research investigated if the individual consultants met the selection criteria mandated by the terms of the consultancy contract before project engagement. This was achieved through an examination of their curriculum vitae's. There were strictly enforced selection criteria governing each of the senior positions. The Programme Director position required a minimum of 20 years' experience in large-scale development projects. The job required previous management of large, complex programs together with a minimum qualification of a 4-year degree in engineering or related technical field, broad general technical and construction background, and registration as a professional (chartered) engineer. The Senior Project Manager position required 15+ years' experience to include ten years in major project design or development, a BSc/BEng in civil engineering, and certification from a recognised professional body. A review of the professional details provided confirmed that each candidate had met or exceeded these mandatory requirements.

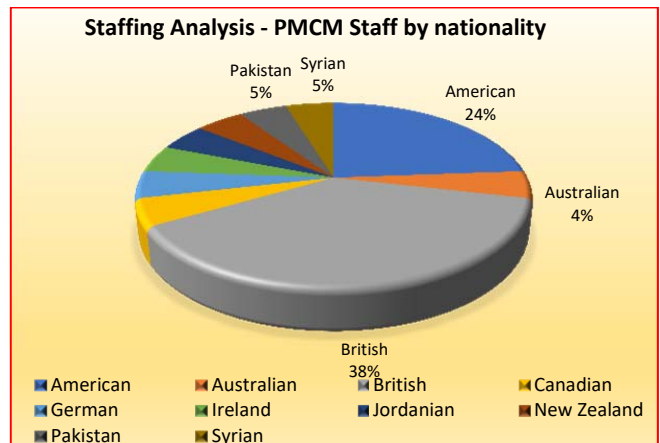

Fig. 2 Nationalities performing PMCM Services

Interestingly, the physical headquarters of the three principle western consultants did not reflect the nationalities engaged on the megaproject. The American registered company employed four American nationals, the German supervision Consultant had no German citizens, but the UK based cost consultant did engage mostly UK nationals (77%). The nationalities for each consultant are as detailed in Figs. 2-4.



Fig. 3 Nationalities performing Site Supervision Services



Fig. 4 Nationalities performing Site Supervision Services

An overall analysis of consultants confirmed 18 different nationalities, confirming the broad cultural diversity in the execution of GCC's megaprojects.

Analysis of the overall staffing matrix by nationality is provided as Fig. 5. The five most common nationalities working for the western consultants which formed part of this case study were British (34%), American (13%), Australian (5%), Canadian (5%) and South African (5%). Cross-culture experts suggest that national culture characteristic analysis may offer a blueprint to what may be expected when dealing with consultants from differing nationalities [26]. Known cultural attributes may provide an anticipatory attitude towards issues of uncertainty or proposals for change or confrontation, in addition to potential management strategies.

The next stage of the investigation explored the underlying reasons associated with the individual's departure; these were categorised as either elective or forced reasons for leaving the

project. The factors linked to a *natural departure* included personal choices such as retirement, career progression, or completion of tenure. Tenure completion occurs when the project has reached the stage where the need for a role undertaken by the individual professional consultant has been fulfilled and is no longer required. Consultants also make lifestyle choices to work abroad for a fixed duration and then return home as planned [68]. In considering natural turnover, it was necessary to find all possible reasons for departure and then thematically categorise these choices. Individual data were coded with a unique identification code. Later the interview transcripts were re-examined, and each interview was reconsidered and analysed until three general categories emerged. After the three groups were addressed, the research focused on Category C candidates - individual professional consultants where the sponsor terminated the contract. The findings were thematically analysed. In summary, the study found five primary causes of unnatural turnover, which ranged from public disagreements to appearing too slow and unproductive. The methodological sequence is detailed in Fig. 6.

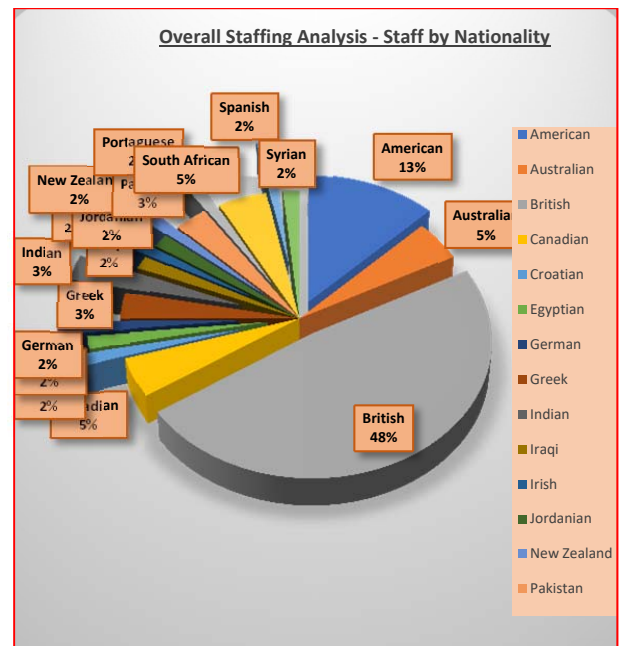

Fig. 5 Overall Staffing by Nationality

V. ANALYSIS OF PILOT STUDY DATA

The first Category A – (Role Completion) reflects the condition that megaprojects are temporary endeavours and individual roles may have a limited but necessary function for part of the megaproject [69], [70], [8]. For example, the RIBA acknowledges differing stages in any project lifecycle from initial concept through to detail design. Once detailed design has been completed, then the need for significant input from the design team is reduced. Category A considers specific time related and functional roles, and if the project requirements had fulfilled that role or if the position had been optimised.

Optimisation occurred where staff was reduced to save costs, allowing minimum levels to remain. Several state-funded GCC megaprojects were subject to such fee reducing measures as a result of the reduction in the availability of state funding between 2015-2018 when the market price of oil

declined [71]. Category A considers staff departures where the consultant had fulfilled the functional role or been optimised, and also includes changing positions as a result of promotions or demotions.

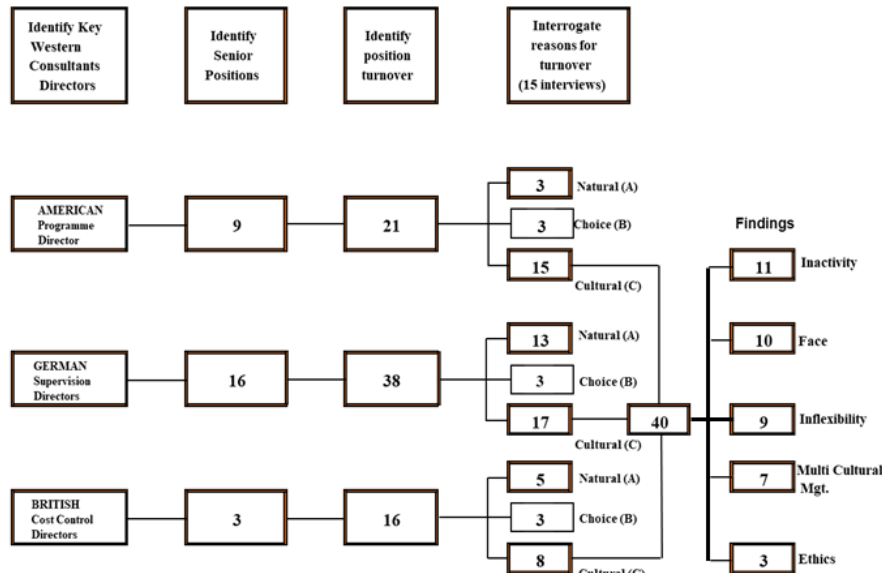

Fig. 6 Removal of Executives form pilot Study

The remaining data were further analysed, and coding was then applied, which identified a second Category B – (Personal Choice). This included consultants who left due to retirement, returned to their home country as planned or received a better employment offer. Participants in this research often held 25 to 40 years plus of post-graduate experience, placing them at a theoretical retirement age of 65. The actual number of participants who retired was three. Category B considers those candidates who had elected to leave.

Categories A and B are considered as natural or elective turnover and not necessarily influenced by cultural dissonance. Although not examined as part of this research, it is accepted that cultural dissonance may have been an unknown factor in some individual cases. In terms of the number of professional consultants impacted, Category A affected 21 personnel. Category B – (Personal Choice) impacted a further 14 professionals who either elected to retire or return to their home country following the end of their overseas service. Through this research, it was also identified (through social media), that two members had since come out of retirement. Cross-cultural experts recommend that it is only appropriate to consider cultural impacts *if all other factors have been reviewed and eliminated* [85]. The departure of the professional consultants who did not fall into Category A or B were then examined to understand the potential phenomena that culture dissonance may have influenced this departure. It was found that 40 departures were linked to cultural disagreements, clustered as Category C – (Culturally impacted). These findings were further thematically analysed,

and sub-clusters identified. The data are presented in Table IV.

In summary, this analysis found that 30 professionals left due to ‘elective’ reasons, such as retirement or a desire to return to their home country; five remained in post, and the remaining 40 were forced to leave their job due to factors influenced by cultural disharmony.

TABLE IV
 SENIOR POSITIONS TURNOVER FOR THE CONSULTANTS

Turnover Analysis of Senior Management		PMCM	SC	CC	Total
Category A	Role fulfilment, optimisation or promotion.	3	13	5	21
Category B	The Choice to return home, retire, engage in a better employment opportunity.	3	8	3	14
Category C	Incompatible culture-related issues.	15	17	8	40
		21	38	16	75

Application of Case Study to Examine Cultural Dissonance Based on Nationality

This analysis considers the nationalities of 40 consultants identified in the pilot case study impacted by cultural dissonance, which resulted in the termination of their employment. There are, of course, complex difficulties in establishing national and ethnic boundaries and therefore in attributing a particular national cultural identity to a specific individual. Researchers are often accused of failing to distinguish between individual and national studies, resulting in the provision of false results [50]. This failure has been labelled as an *ecological fallacy* level [72] or believing that national-level averages apply to all individuals of that nation.

For this research, we have used a pragmatic approach that is not applied at a fine grain level, but we consider sufficient to provide robust indicators of the impact of cultural dissonance on mega-projects in a particular and specific context.

Findings Concerning Nationalities Impacted by Cultural Dissonance

The case study identified five categories of cultural dissonance, summarised as follows:

Finding 1 - A Perception of Being Too Slow or Not Active Enough (Inactivity)

There are several instances where the sponsor considered that the consultant did not appear dynamic enough to justify the level of expertise that the position commanded. Arabs have a tendency to multitask [58]. This characteristic explains how Arabs exhibit multi-linear, multi-active tendencies and suggests such characteristics as manifesting as appearing extrovert, impatient, talkative, curious, doing several things at once, not punctual, changing plans, juggling plans, delegating to relations. In practice, it is common to seek out the top management and frequently interrupts [58]. In line with the sponsor's beliefs, this may lead to interpreting a slow

methodological approach as inactivity or complacency. In this study, British and Canadian citizen, followed by Canadian and New Zealanders were the most impacted by the sponsors' interpretation of this finding.

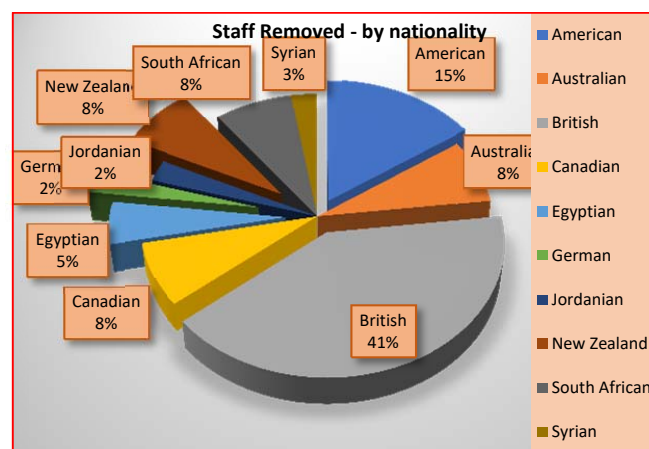

Fig. 7 Analysis of Turnover by Nationality

TABLE V
 NATIONALITIES DISPLACED DUE TO CULTURAL DISSONANCE

Country	Finding 1 Inactivity	Finding 2 Face	Finding 3 Inflexibility	Finding 4 Multi-cultural Management	Finding 5 Ethical	Total Consultants Removed
Australia	1	1				2
Great Britain	3	2	7	3	1	16
Canada	2					2
New Zealand	2	1				3
South Africa	2	2				3
United States		3	1		1	5
Jordan, Syria, Germany, Greece, Pakistan, Egypt	3	2	1	2	1	9
Totals	12	11	9	5	3	40

Finding 2 - Public Displays of Criticism and Unacceptable Behaviours (Face)

Local project sponsors removed several consultants due to public confrontation. Formal correspondences were issued for consultants to dismiss staff for lack of respect for an employer who publicly challenged the sponsors' authority. The emotional dimension *face* is derived from a Chinese concept described as *dignity based on a correct relationship between a person and the collectives to which he belongs* [72]. It is suggested that while society has become more tolerant over the years, the concept of face is still prominent within the Middle East [86]. It is suggested that a loss of face occurs through *insult or criticism in front of others* [34]. This loss of face is considered more painful than physical mistreatment [73]. It is suggested that a good personal relationship is the most critical factor when doing business with the Arab world [74]. The nations most impacted by this factor were from the USA, followed by the South Africans and British.

Finding 3 – A Lack of Flexibility in the Adoption of Local Norms (Inflexibility)

Overly rigid interpretations of contract documents or

practices and insistence on a 'home country' standard can be interpreted as non-professional. The sponsor expressed concerns as to the consultant rigidity in norms applied. Global consultancies are continually struggling to harmonise their core policies globally [33], [75]. There are some aspects to each professional discipline that cannot carry through all regions, so rather than insisting on replicating each specific national standards, a *healthy dose of particularism* is often required [76]. The sponsor expects local norms and practices be implemented. Cross-cultural specialists recommend that expatriates must be open and flexible, willing to communicate, socially adaptable, and manage stress as part of the adjustment process [77]. The most impacted nations for this finding was the UK.

Finding 4 – Failure to Manage the Multi-Cultural Workforce (Multi-Cultural Management)

The project sponsor, in some cases, expressed the view that managers were unable to control their teams. Failure to manage a team became an issue in several instances in which the senior manager was not seen to be able to coordinate and control his junior managers. These failures were noted through

cases where the team leader allowed speaking over the projects team, where policies and approaches were not in line with local norms, or where the manager was not considered sufficiently involved. Team management is also indirectly related to an Arab multi-linear tendency [58]. Failures or delays in ensuring works are completed to deadlines was also perceived as inexperienced management. The sponsor expects active leadership and guidance from the consultant. Leadership is considered as a global challenge, and not restricted to the GCC. The prescreening and acceptance criteria for engagement were designed to ensure the leadership skills were adequate for the project. UK consultants were the most impacted nations for this finding.

Finding 5 - Ethical Concerns (Ethics)

Three consultants were removed from office for ethical considerations. On two occasions, the sponsor suspected the professional consultant to be working 'too closely' with the contractor. While ethical issues are a global phenomenon, it is noteworthy that one consultant was also removed for crossing boundaries with female Qatari staff. National characteristics associated with Arab nations confirm that they are family orientated, conservative, religious, and consultative [78], [79], [63]. Family orientation has resulted in a small percentage of females working in the GCC. Specific guidance concerning not seeking direct eye contact or shaking hands are available and must be respected, as gender cultural issues differ significantly from western norms. No particular nation dominated ethics findings, and what occurred appear to have been isolated issues.

This pilot study has been further expanded to consider the experiences of 25 construction directors of Western Consultants active within megaprojects throughout the GCC. Although the research is ongoing, issues related to Face and removal of consultants due to perceived inactivity appear frequently. The full findings will be available in late 2022.

The research carried out to date suggests the following steps may contribute to mitigating the risk arising from cultural dissonance:

Managing Risk: Identification of cultural risk is only the beginning of the process -those involved in Risk Management suggest that the best strategy for managing risk is *to approach the uncertainty in a structured way to maximise success* [80]. The identification of significant turnover amongst western consultants in a pilot study on GCC megaprojects, resultant from cultural dissonance, is the initial step in the process. Risk management aims first to identify risk and then to avoid, control, transfer or mitigate all hazards. Initial finding from on-going field research suggests the following mitigative measures.

Dedicated Training: Most respondents did not feel prepared for working life in the GCC and suggested that training would be beneficial, although the format of this training ranged from a half-day workshop to a several days workshop. There were further training queries related to the leadership of megaprojects, where participants believe that additional training was required. The variety of training proposed

included suggestions for enhanced communication skills, the teaching of the Arabic language, and a range of training including cultural awareness, empathy and people and intercultural management. There are cultural experts and software analysis that aim to provide constructive advice before engagement with a new culture.

Ethnocentricity: As long as wealth exists and borders remain open, the GCC is likely to remain a very multi-cultural environment. It is apparent that local standards need to be respected, and there needs to be an awareness that the GCC has been engaged in megaprojects for almost five decades. The virtues of tolerance and flexibility are portrayed as critical findings, and an open attitude to how the GCC operates is fundamental to success.

Strong Leadership: Professionalism is required, together with an active and confident managerial approach, and these appear to be prerequisite to succeeding in megaproject management.

Cultural integration: This relates to a human element or the 'soft skill' of personnel management. These observations are echoed by specialised recruitment agencies such as [81] who suggest that a critical requirement recognised in placing executives in megaprojects is the need for those taking up the posts to learn the soft skills necessary to manage cultural differences.

VI. CONCLUSIONS

Risk Identification leads to Risk mitigation. Research has confirmed that cultural dissonance is a risk factor during megaproject execution [16], [82], [83], and this research demonstrates that it is a significant risk factor in GCC megaprojects. In the GCC, there is often a considerable cultural distance between the local project sponsor and the expatriate consultant (Table III). This case study links high staff turnover, to associated delays and disruption to the project execution, while staff is replaced. It appears that these staff replacements are often the result of miscommunication and failure to appreciate the culture of the sponsor. However, it is suggested that these miscommunications and cultural clashes can be reduced through a better understanding of the host nations cultural beliefs and practices. We found that experienced GCC megaproject professional consultants were adept at promoting cultural awareness to assist with cultural integration. They also recognised that dedicated training might help reduce culture shock and make cultural integration easier.

On-going research confirms that a failure to accept and appreciate cultural differences is currently impacting negatively on the execution of GCC megaprojects. Based on our interim findings, it is apparent that adaptability and flexibility are critical characteristics required when executing GCC megaprojects. Although more work is needed, it is also suggested that different nationalities are more or less flexible in adopting and adapting to the local GCC's culture. The research highlights the necessity to respect cultural etiquette, including recognising *face*, a need for public harmony and the adoption of active leadership. In this study, British consultants experienced the most difficulty with adopting and adapting to

local norms and standards. Americans consultants were least accepting of the need to respect professional dignity and keep disputes private. Canadians and British consultants experienced difficulty in demonstrating a management style to suit the sponsors' expectations. British consultants were often removed due to a failure to describe what the local project sponsor considered to be 'strong leadership skills'. Notwithstanding the on-going nature of this research, evidence to date suggests that culture is a significant risk factor for western consultants currently executing GCC megaprojects.

REFERENCES

- [1] GLOBE. (2019). Results - Anglo GLOBE Project. Retrieved June 29, 2019, from [Globeproject website: https://globeproject.com/results/clusters/anglo?menu=list#list](https://globeproject.com/results/clusters/anglo?menu=list#list)
- [2] Flyvbjerg, B. (2013). Quality control and due diligence in project management: Getting decisions right by taking the outside view. *International Journal of Project Management*, 31(5), 760–774. <https://doi.org/10.1016/j.ijproman.2012.10.007>
- [3] Capka, J. R. (2004). Megaprojects -They Are A Different Breed. Federal Highway Administration.
- [4] Davies, A., Dodgson, M., Gann, D. M., & Macaulay, S. C. (2017). Five Rules for Managing Large, Complex Projects.
- [5] Flyvbjerg, B. (2017). *The Oxford Handbook of Megaproject Management*.
- [6] Mok, K. Y., Shen, G. Q., & Yang, J. (2015). Stakeholder management studies in mega construction projects: A review and future directions. *International Journal of Project Management*, 33(2), 446–457. <https://doi.org/10.1016/j.ijproman.2014.08.007>
- [7] Pollack, J., Biesenthal, C., Sankaran, S., & Clegg, S. (2018a). Classics in megaproject management: A structured analysis of three significant works. *International Journal of Project Management*, 36(2), 372–384. <https://doi.org/10.1016/j.ijproman.2017.01.003>
- [8] Turner, J. R. (2018). The management of the project-based organisation: A personal reflection. *International Journal of Project Management*, 36, 231–240. <https://doi.org/10.1016/j.ijproman.2017.08.002>
- [9] Hillson, D. (2012). How much risk is too much risk? Understanding risk appetite. *PMI Global Congress Proceedings*, 1–7. <https://doi.org/10.1103/PhysRevB.89.115114>
- [10] Pollack, J., Biesenthal, C., Sankaran, S., & Clegg, S. (2018b). Classics in megaproject management: A structured analysis of three major works. *International Journal of Project Management*. <https://doi.org/10.1016/j.ijproman.2017.01.003>
- [11] Dyer, R. (2017). Cultural sense-making integration into risk mitigation strategies towards megaproject success. *International Journal of Project Management*, 35(7), 1338–1349. <https://doi.org/10.1016/j.ijproman.2016.11.005>
- [12] Flyvbjerg, B. (2018). *PMI REVIEW Are project forecasters “fools or liars”?* 4–7.
- [13] Söderlund, J. |, Sankaran, S. |, Biesenthal, C., Söderlund, J., Sankaran, S., & Otto, W. -. (2017). The Past and Present of Megaprojects. *Project Management Journal*, 48(6), 5–16. Retrieved from <https://www.pmi.org/learning/library/past-present-megaprojects-10985>
- [14] Flyvbjerg, B., Bruzelius, N., & Rothengatter, W. (2003). Megaprojects and Risk An Anatomy of Ambition (Vol. 4). <https://doi.org/10.1177/147309520500400107>
- [15] Van Marrewijk, A., Smits, K., Clegg, S. R., Pitsis, T. S., & Veenswijk, M. (2008). Managing public-private megaprojects: Paradoxes, complexity, and project design. *International Journal of Project Management*, 26(3), 591–600. <https://doi.org/10.1016/j.ijproman.2015.07.004>
- [16] Merron. (1988). *Merron1988 - Understanding the Outcomes of Mega-Projects* (page vi).
- [17] Walsh, A., & Walker, P. (2019). Trust in Major & Mega Projects. In *IPMA (Ed.), Trust in Major & Mega Projects* (Vol. 1, pp. 1–933). Zagreb: Croatian Association for Construction Management (page 231).
- [18] Archibald, R. D. (1991). Overcoming cultural barriers in project management. *Project Management Journal*, 5(4), 27–30. Retrieved from <http://marketplace.pmi.org/Pages/ProductDetail.aspx?GMProduct=00100568800&iss=1>
- [19] Dulaimi, M., & Hariz, A. (2011). The impact of cultural diversity on the effectiveness of construction project teams. *Engineering Project Organization Journal*, 1(4), 213–221. <https://doi.org/10.1080/21573727.2011.621419>
- [20] El-sabek, L. M. (2017). Framework for managing integration challenges of production planning and control in international construction megaprojects
- [21] Karahanna, E., Evaristo, R. J., & Srite, M. (2005). Levels of Culture and Individual Behavior: An Integrative Perspective. *Journal of Global Information Management*, 13(2), 1–20. <https://doi.org/10.4018/jgim.2005040101>
- [22] Egan, J. (1998). Rethinking the Report of the Construction Task Force. *Construction*, 38. <https://doi.org/Construction Task Force. Uk Government>
- [23] Foxwell, S. (2019). Professionalism in the Built Environment. In *BRI*. [https://doi.org/ISBN: 978-1-138-90020-2 \(hbk\)](https://doi.org/ISBN: 978-1-138-90020-2 (hbk))
- [24] Latham, M. (1994). Constructing the team: a joint review of procurement and contractual arrangements in the United Kingdom construction industry. *Hmso*, 53(9), 1689–1699. <https://doi.org/10.1017/CBO9781107415324.004>
- [25] Trompenaars, F. (1993). Riding the waves of cultures. <https://doi.org/10.3163/1536-5050.96.2.85>
- [26] Waisfisz, B. (2015). *Constructing the Best Culture to Perform*.
- [27] Trompenaars, F., & Woolliams, P. (2006). Getting the measure of culture: from values to business performance. *Adaptive Options*.
- [28] GLOBE. (2004). Understanding the Relationship Between National Culture, Societal Effectiveness and Desirable Leadership Attribute: A Brief Overview of the GLOBE Project. *Globe*, 1–4. Retrieved from http://globeproject.com/study_2004_2007
- [29] Hofstede, G. (1991). *HOFSTEDE: Cultures And Organizations - Software of the Mind*. Development, 1–29. Retrieved from <http://westwood.wikispaces.com/file/view/Hofstede.pdf>
- [30] Trompenaars, F., & Woolliams, P. (2003). A new framework for managing change across cultures. *Journal of Change Management*, 3, 361–375.
- [31] Hofstede, G. J., Pedersen, P. B., & Hofstede, G. (2002a). Exploring Culture.
- [32] Inglehart, Roland. (1997). World Values Surveys and European Values Surveys, 1981–1984, 1990–1993, and 1995–1997. *ICPSR Inter-University Consortium for Political and Social Research*, 1990–1993. <https://doi.org/10.1111/febs.12522>
- [33] Schein, E. H. (2004). *Organisational Culture and Leadership*. *Leadership*, 7, 437. <https://doi.org/10.1080/09595230802089917>
- [34] Hammerich, K., & Lewis, R. D. (2013). Fish can't see water.
- [35] Myer, E. (2018). *Erin Meyer Website*. (October 2013).
- [36] Hofstede, G., Hofstede, G. J., & Minkov, M. (2010). *Cultures and Organizations: Software of the Mind*, Third Edition. McGraw-Hill Education; 3 Edition, 38(1), 576. <https://doi.org/10.2307/2393257>
- [37] Strodbeck, K. &. (1961). Variations in value orientations.
- [38] Taras, V., Rowney, J., & Steel, P. (2009). Half a century of measuring culture: Review of approaches, challenges, and limitations based on the analysis of 121 instruments for quantifying culture. *Journal of International Management*, 15(4), 357–373. <https://doi.org/10.1016/j.intman.2008.08.005>
- [39] Minkov, M., Dutt, P., Schachner, M., Jandosova, J., Khassenbekov, Y., Morales, O. ... Mudd, B. (2018). What Values and Traits Do Parents Teach to Their Children? New Data from 54 Countries. *Comparative Sociology*, 17(2), 221–252. <https://doi.org/10.1163/15691330-12341456>
- [40] Smith, P. B. (2006). When elephants fight, the grass gets trampled: The GLOBE and Hofstede projects. *Journal of International Business Studies*, 37(6), 915–921. <https://doi.org/10.1057/palgrave.jibs.8400235>
- [41] Beugelsdijk, S., & Welzel, C. (2018). Dimensions and Dynamics of National Culture: Synthesizing Hofstede with Inglehart. *Journal of Cross-Cultural Psychology*, 49(10), 1469–1505.
- [42] Venkateswaran, R. T., & Ojha, A. K. (2019). Abandon Hofstede-based research? Not yet! A perspective from the philosophy of the social sciences. *Asia Pacific Business Review*, 00(00), 1–22. <https://doi.org/10.1080/13602381.2019.1584487>
- [43] Minkov, M., & Hofstede, G. (2012). Hofstede's fifth dimension: New evidence from the world values survey. *Journal of Cross-Cultural Psychology*, 43(1), 3–14. <https://doi.org/10.1177/0022022110388567>
- [44] Smith, P. B., Dugan, S., & Trompenaars, F. (1996). National culture and the values of organisational employees: A dimensional analysis across 43 nations. *Journal of Cross-Cultural Psychology*, 27(2), 231–264. <https://doi.org/10.1177/0022022196272006>
- [45] Sondergaard, M. (2001). Geert Hofstede, Culture's Consequences:

- Comparing Values, Behaviours, Institutions, and Organizations Across. *International Journal of Cross-Cultural Management*, (January), 447–456. <https://doi.org/10.1002/ejoc.201200111>
- [46] Beugelsdijk, S., Kostova, T., & Roth, K. (2017). An overview of Hofstede-inspired country-level culture research in international business since 2006. *Journal of International Business Studies*, 48(1), 30–47. <https://doi.org/10.1057/s41267-016-0038-8>
- [47] Beugelsdijk, S., Maseland, R., & van Hoorn, A. (2015). Are Scores on Hofstede's Dimensions of National Culture Stable over Time? A Cohort Analysis. *Global Strategy Journal*, 5(3), 223–240. <https://doi.org/10.1002/gsj.1098>
- [48] Eringa, K., Caudron, L. N., Rieck, K., Xie, F., & Gerhardt, T. (2015). How relevant are Hofstede's dimensions for intercultural studies? A replication of Hofstede's research among current international business students. *Research in Hospitality Management*, 5(2), 187–198. <https://doi.org/10.1080/22243534.2015.11828344>
- [49] Devinney, T. M., & Hohberger, J. (2017). The past is prologue: Moving on from Culture's Consequences. *Journal of International Business Studies*, 48(1), 48–62. <https://doi.org/10.1057/palgrave.jibs.8400202>
- [50] Kirkman, B. L., Lowe, K. B., & Gibson, C. B. (2006). A quarter-century of culture's consequences: A review of empirical research incorporating Hofstede's cultural values framework. *Journal of International Business Studies*, 37(1), 285–320. <https://doi.org/10.1057/palgrave.jibs.8400202>
- [51] Minkov, M., Dutt, P., Schachner, M., Morales, O., Sanchez, C., Jandosova, J., ... Mudd, B. (2017). A revision of Hofstede's individualism-collectivism dimension: A new national index from a 56-country study. *Cross-Cultural and Strategic Management*, 24(3), 386–404. <https://doi.org/10.1108/CCSM-11-2016-0197>
- [52] van Witteloostuijn, A. (2016). What happened to Popperian falsification? Publishing neutral and negative findings. *Cross-Cultural & Strategic Management*, 23(3), 481–508. <https://doi.org/10.1108/CCSM-03-2016-0084>
- [53] McSweeney, B. (2013). Fashion founded on a flaw: The ecological mono-deterministic fallacy of Hofstede, GLOBE, and followers. *International Marketing Review*, 30(5), 483–504. <https://doi.org/10.1108/IMR-04-2013-0082>
- [54] McSweeney, B., Brown, D., & Iliopoulou, S. (2016). Claiming too much, delivering too little: testing some of Hofstede's generalisations. *The Irish Journal of Management*, 35(1), 34–57. <https://doi.org/10.1515/ijm-2016-0003>
- [55] Fang, T. (2003). A critique of Hofstede's fifth national culture dimension. *International Journal of Cross-Cultural Management*, 3(3), 347–368. <https://doi.org/10.1177/1470595803003003006>
- [56] Hofstede. (2015). Background of the Hofstede Multi-Focus Model on Organisational Culture: the Research Instrument. <https://doi.org/10.2307/239339>
- [57] Oberg, K. (1960). Cultural Shock: Adjustment to New Cultural Environments. *Practical Anthropology*. <https://doi.org/10.1177/009182966000700405>
- [58] Lewis, R. D. (2016). When Cultures Collide : Leading Across Cultures. <https://doi.org/10.1108/eb059499> (page 19)
- [59] Hofstede, G., Jan, H. G., & Michael, M. (2010). *Cultures and Organizations - Software of the Mind - 3rd Edition*. In *Cultures and Organizations*. <https://doi.org/10.1007/s11569-007-0005-8>
- [60] Kultur, T., Chalhoun, N., & Justice, D. (2005). Ryszard Kapuscinski: On Others. *Religion*, (87).
- [61] Naeem, A., Nadeem, A. Bin, & Khan, I. U. (2015). Culture Shock and Its effects on Expatriates. *Global Advanced Research Journal of Management and Business Studies*, 4(6), 2315–5086. Retrieved from <http://garj.org/garjmbs/index.htm>
- [62] Inglehart, R. F. (2018). Cultural Evolution
- [63] Moran, R. T., Harris, P. R. ., & Moran, S. V. (2011). Managing Cultural Differences. In *Managing Cultural Differences*. <https://doi.org/10.1016/B978-1-85617-923-2.00015-X>
- [64] Robin Kay. (2014). *Passing the PMP (R) Examination (PMBOK (R) Fifth Edition)*. E. 249.
- [65] Black, J. S., & Gregersen, H. B. (1999). The Right Way to Manage Expats. *International Business*, 2(March-April). Retrieved from <http://www.hbsp.harvard.edu>
- [66] Harrison, J. (1994). Developing successful expatriate managers: a framework for the structural design and strategic alignment of cross-cultural training programs. *Human Resource Planning*, 17, 17–35. Retrieved from <http://onlinelibrary.wiley.com/doi/10.1002/>
- [67] Leiß, G. (2013). *International Human Resource Management Master ,, International Business “*. 1–125.
- [68] Cole, N., & Nesbeth, K. (2014). Why Do International Assignments Fail? *International Studies of Management and Organization*, 44(3), 66–79. <https://doi.org/10.2753/IMO0020-8825440304>
- [69] Brookes, N., Sage, D., Dainty, A., Locatelli, G., & Whyte, J. (2017). An island of constancy in a sea of change: Rethinking project temporalities with long-term megaprojects. *International Journal of Project Management*, 35(7), 1213–1224. <https://doi.org/10.1016/j.ijproman.2017.05.007>
- [70] Dwivedula, R., Bredillet, C., & Müller, R. (2018). Work Motivation in Temporary Organizations: Establishing Theoretical Corpus. *Management and Organizational Studies*, 5(3), 29–42. <https://doi.org/10.5430/mos.v5n3p29>
- [71] Deloitte GCC. (2016). *Deloitte GCC Powers of Construction 2016 The funding equation*.
- [72] Hofstede, G. (2011). Dimensionalizing Cultures: The Hofstede Model in Context. *Online Readings in Psychology and Culture*, 2(1), 1–26. <https://doi.org/10.9707/2307-0919.1014> (Ref page 7)
- [73] Hofstede, G. (1983). *Cultural Dimensions in Management and Planning*. Conference Paper, 1–15.
- [74] Meyer, E. (2014). *The Culture Map*.
- [75] Trompenaars, F., & Woolliams, P. (2006). *Getting the measure of culture: from values to business performance*. Adaptive Options.
- [76] Trompenaars, F., & Woolliams, P. (2001). *Dilemmas of Multi-Cultural Leaders A New Unified Model of Trans-Cultural Competence*. Velocity, Quarter 1.
- [77] Waxin, M.-F. (2004). Expatriates' interaction adjustment: the direct and moderator effects of culture of origin. *International Journal of Intercultural Relations*, 3(4), 527–528. [https://doi.org/10.1016/0147-1767\(79\)90014-2](https://doi.org/10.1016/0147-1767(79)90014-2)
- [78] Bakhtiari, H. (1995). Cultural Effects on Management Style. *Int. Studies OfMgt. & Org*, 25(3), 97–118.
- [79] Erin, M. (2014). *Navigating the cultural minefield*. Harvard Business Review, 92(May).
- [80] Hillson, D. (2018). *Managing risk in complex megaprojects (webinar) - YouTube*. Retrieved February 2, 2019, from Online website: <https://www.youtube.com/watch?v=PZiuARCSSTM>
- [81] Struggles & Heindrick. (2015). *A new era for megaproject leadership*.
- [82] Smits, K., & Brownlow, R. A. (2017). *Collaboration and Crisis in Mega Projects: A Study in Cross Corporate Culture Conflict and its Resolution*. *Independent Journal of Management & Production*, 8(2), 395. <https://doi.org/10.14807/ijmp.v8i2.556>
- [83] Van Marrewijk, A. H. (2018). Introduction: a megaproject as culture perspective. *Inside Mega-projects: Understanding 5*(2015), 2018.
- [84] *Culture ComPass™ Consolidated Report, 2014*.
- [85] Discussion Egbert Schram CEO Hofstede Insights April 2019
- [86] Webb, E. (2015). A contract manager abroad: cultural awareness in Asia. *Proceedings of the Institution of Civil Engineers - Management, Procurement and Law*, 168(6), 261–268. <https://doi.org/10.1680/jmapl.15.00034>