

The Delaying Influence of Degradation on the Divestment of Gas Turbines for Associated Gas Utilisation: Part 1

Mafel Obhuo, Dodeye I. Igbong, Duabari S. Aziaka, Pericles Pilidis

Abstract—An important feature of the exploitation of associated gas as fuel for gas turbine engines is a declining supply. So when exploiting this resource, the divestment of prime movers is very important as the fuel supply diminishes with time. This paper explores the influence of engine degradation on the timing of divestments. Hypothetical but realistic gas turbine engines were modelled with Turbomatch, the Cranfield University gas turbine performance simulation tool. The results were deployed in three degradation scenarios within the TERA (Techno-economic and environmental risk analysis) framework to develop economic models. An optimisation with Genetic Algorithms was carried out to maximize the economic benefit. The results show that degradation will have a significant impact. It will delay the divestment of power plants, while they are running less efficiently. Over a 20 year investment, a decrease of \$0.11bn, \$0.26bn and \$0.45bn (billion US dollars) were observed for the three degradation scenarios as against the clean case.

Keywords—Economic return, flared associated gas, net present value, optimisation.

I. INTRODUCTION

IN some parts of the world, associated gas is being wasted to flaring. Associated gas can be defined as natural gas that is found in a mixture with crude oil within a reservoir [1], [2]. Associated gas flaring is the controlled burning of natural gas produced in a mixture with crude oil in the process of routine oil and gas production operations. The option of releasing natural gas to the atmosphere by flaring is a key practice in oil and gas production, mainly for safety concerns [3].

Associated gas flaring leads to great economic waste and life-threatening environmental pollution. Very great quantity of energy and economic return are derivable when associated gas is being utilised as fuel for industrial gas turbines. In order to invest in the economic utilisation of associated gas for power generation using gas turbine engines, a model would be needed to evaluate the best divestment time for the redundant units of engines and to estimate the effect of gas turbine

M. Obhuo was with Cranfield University, Bedfordshire, MK43 0AL UK. He is now with the Nigeria Maritime University, Okerenkoko, Delta State, Nigeria (corresponding author, phone: +2349038633366; e-mail: obhuo.mafel@nmu.edu.ng).

D. I. Igbong was with Cranfield University, Bedfordshire, MK43 0AL UK. He is now with the Department of Mechanical Engineering, Cross River University of Technology, Calabar, Cross River State, Nigeria (e-mail: d.i.igbong@crutech.edu.ng).

D. S. Aziaka and P. Pilidis are with the Propulsion Engineering Centre, Cranfield University, Bedfordshire, MK43 0AL UK (e-mail: d.aziaka@cranfield.ac.uk, p.pilidis@cranfield.ac.uk).

degradation on the divestment time. The redundancy of some units of the engine is due to insufficient associated gas availability over the duration of the project. Over time, gas turbines exhibit the effects of wear and tear; this necessitated the need to consider the effect of degradation on divestment time. AD43 engine is the gas turbine engine used for this study; it is inspired from the General Electric LM6000 engine. It is a two-shaft, simple-cycle, high performance gas turbine engine.

A. Fuel Resources and Associated Gas Availability

Fig. 1 shows the data for the associated gas availability for the project for a period of 20 years. The gradual decline as seen in Fig. 1 is as a result of the natural depletion of natural gas which is the source of associated gas. Clean natural gas and associated gas were used as fuel for simulating the performance of the same model engines. It was observed that the performance results showed close similarity and there was no significant difference between the results for both fuels [4, p.60-71], [9, p.142, 144]; clean natural gas was therefore used in the simulations presented in this paper in place of associated gas.

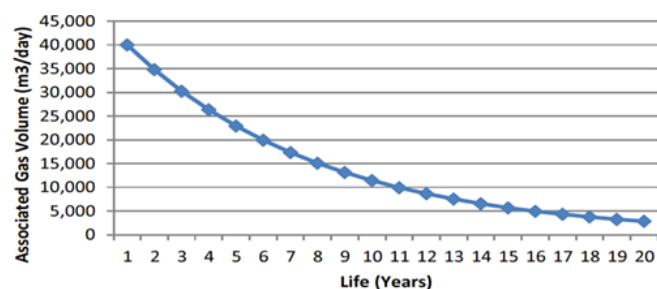

Fig. 1 Associated Gas Decline over 20 Years Period [1]

B. Gas Turbine Divestment

At some point in the life span of this project, some units of engines in the fleet will become redundant due to limited associated gas availability as seen in Fig. 1. The best economic decision would be to divest the redundant engines. Any government, industry or organisation intending to invest in the economic use of associated gas using gas turbines should make proper plans on when to start divesting the redundant units of engines.

The option of which gas turbine unit to divest out of all the engines in the fleet considered involves selection of engine units and the management of the redundant units of engines.

For a given associated gas production profile and a selected fleet of engines; the number of engines to be withdrawn and the timing are major decisions to be taken. The number of redundant units of engines is dependent on two major factors; they are the decline rate of the associated gas and the Ultimate Recoverable Resources (URR) [4].

Reference [4] did some work on divestment of engine units. The research employed a methodology in which the engine unit divestment algorithm depended on the output from the associated gas production profile module in order to predict the power plant engine mix. Also, this prediction was based on the available engine within the eight engines used as study engines. In order to ascertain the exact engine due for divestment, the determinant factors used were the performance and economic parameters of the engines. The thermal efficiencies and fuel consumptions of the engines are the performance parameters considered, whereas, the economic criterion considered is the purchased equipment cost (PEC) of the gas turbine unit. Results show that achieving engine operation with engine divestment option requires multiple mix of engine units. Also, it was observed that due to the divestment stratagem used, there was increase in the economic performance of the power plants considered [4].

Reference [1] worked on the use of associated gas for power generation. They analysed the effect of degradation on the economic utilisation of associated gas, and showed the onset of resource decline and the palliative divestment protocol. They suggested that it is very needful to explore the influence of gas turbine degradation on the divestment time for the redundant engines.

Regarding the economic use of associated gas using gas turbine engines, the research gap as seen in the public domain is the lack of literature that demonstrates the effect of engine degradation on the divestment time for the redundant units of engines. This is very vital for investors who would like to invest in the economic use of associated gas fuel using gas turbine engines.

C. Gas Turbine Degradation and Levels of Degradation Considered

Over time, gas turbines exhibit the effects of wear and tear. The long life span of this associated gas utilisation project prompted the need to explore the effect of degradation on the divestment time and on the economic return from the fleets. The effect of degradation on engine divestment time is the key interest in this research. Degradation in the compressor accounts for more than 50% the degradation that occurs in the gas turbine engine, as a result, this work only considered degradation in the compressor of the engine.

The degradation is assumed to be caused by Compressor fouling. Varying levels of gas turbine degradation were implemented for the compressor pressure ratio, non-dimensional mass flow and efficiency; this was done in the performance simulation model used for the degraded engines. The degradation was implemented for the above three parameters because the degradation in the compressor affects the compressor pressure ratio, flow capacity and efficiency

[1]. The effects of varying levels of degradation on the project are considered. These varying levels of degradation are designated as optimistic (slow), medium and pessimistic (fast) degradation.

II. METHOD DESCRIPTION

This study is about optimising power generation and maximising the economic returns of various fleets of gas turbines, and also to explore the influence of engine degradation on the divestment time for the redundant units of engines. The TERA (Techno-economic & environmental risk assessment) and optimisation models from this study will serve as decision-making guide for governments, industries and organisations who want to invest in the economic utilisation of associated gas for power generation using gas turbines. The duration for this project is 240 months (20 years).

TABLE I
 LEVELS OF GAS TURBINE DEGRADATION CONSIDERED

Year	Optimistic (%)	Medium (%)	Pessimistic (%)
1	0	0	0
2	1.333	2.666	4.0
3	2.0	4.0	6.0
4	0.667	1.333	2.0
5	1.333	2.666	4.0
6	2.0	4.0	6.0
7	0.667	1.333	2.0
8	1.333	2.666	4.0
9	2.0	4.0	6.0
10	0.667	1.333	2.0
11	1.333	2.666	4.0
12	2.0	4.0	6.0
13	0.667	1.333	2.0
14	1.333	2.666	4.0
15	2.0	4.0	6.0
16	0.667	1.333	2.0
17	1.333	2.666	4.0
18	2.0	4.0	6.0
19	0.667	1.333	2.0
20	1.333	2.666	4.0

In order to ascertain the accuracy of the results that were obtained from the optimised fleets of engines, there is a baseline analysis of the same results obtained from the optimiser. For the purpose of comparison, the same TERA approaches were adopted for the baseline and optimised fleet (of the same type of engine). However, the methodology used in ascertaining the best divestment time for the redundant engines in the baseline fleet varies from that which was used for the optimised fleets. The fleet composition and best divestment times for the redundant units of engines for the optimised fleets were given by the optimiser while that for the baseline fleet were ascertained through critical human techno-economic judgement.

The TERA methodology for the baseline scenario is shown in Fig. 2. As seen in Fig. 2, the first action is to decide the initial fleet; this is followed by operating the engines with the

associated gas available per year of the project. The performance simulations of the engines were done using a Cranfield University in-house FORTRAN-based code called TURBOMATCH. This code is used in simulating both design and off-design point engine operating conditions.

The fuel flow for operating the engine at design point is known (from public domain); the sum of the fuel flow for all the units of engines in the fleet (ΣF) is calculated. FL is the designation for the fuel flow of the last unit of engine in the fleet. There is a gradual decrease in the fuel available (FA) as the project goes on progressively from one year to the other. For each year of the project the following conditions will be considered (Fig. 2);

- Is $(\Sigma F - FL) > FA$? (Condition 1):
 If a “NO” is the answer to condition 1, a second condition will be considered;
- Is $(\Sigma F) \leq FA$ or is $(\Sigma F) > FA$? (Condition 2)

If “ $(\Sigma F) \leq FA$ ” is the answer for condition 2, it means that there is sufficient fuel that will meet the fuel consumptions of all the units of engines in the fleet when they are all operated at design point. On the other hand, if “ $(\Sigma F) > FA$ ” is the answer for condition 2, it means that the FA will not be sufficient to meet the fuel consumptions of all the units of engines in the fleet when they are all operated at design point, it therefore implies that the last unit of engine in the fleet will be operated at part-load condition. If “YES” is the answer for Condition 1, the last unit of engine in the fleet should be divested, it implies that the FA is not sufficient to meet the fuel consumptions of all the engines in the fleet, even if the last unit of engine in the fleet is operated at part-load condition. This redundant unit of engine is divested and the divestment sale is incorporated into the economic analysis for the fleet as seen in Fig. 2.

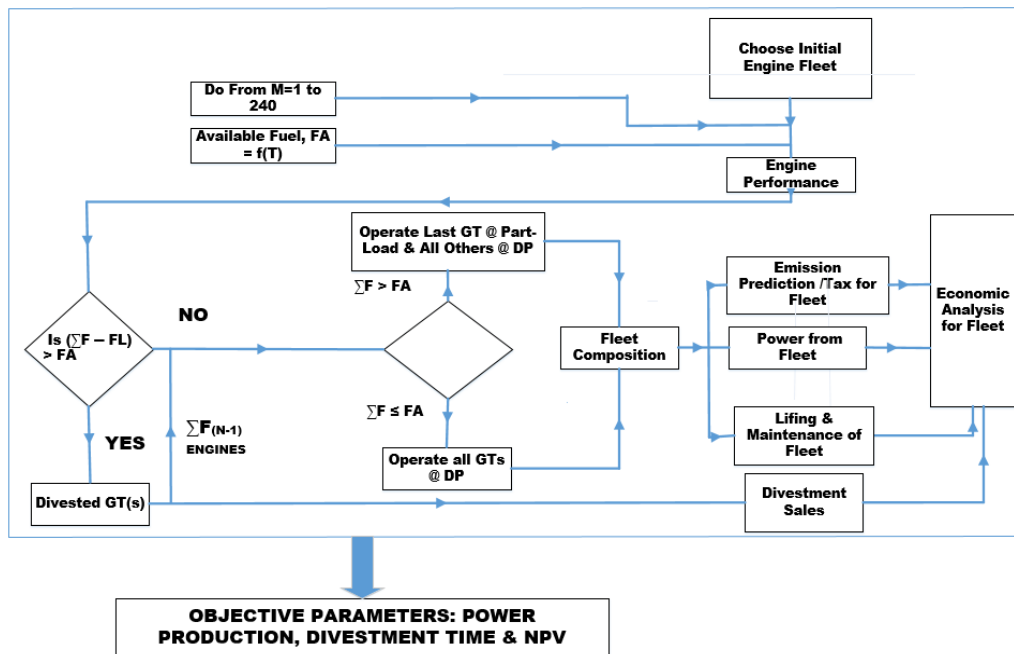

Fig. 2 TERA Methodology for Associated Gas Utilisation (Baseline)

The methodology adopted for the optimised fleets is shown in Fig. 3. It is similar to that of the baseline fleet, the only difference is that the optimiser gives the best divestment time for the optimised fleets. The optimiser ascertains the most techno-economic favourable time to divest the redundant unit (s) of engines in the fleet. The outcome of the optimised best divestment times for the units of engines in the degraded fleets will demonstrate the influence of engine degradation on divestment time; this is the key contribution to knowledge presented by this paper.

III. RESULTS AND DISCUSSION

A. Optimised Best Divestment Time and the Effect of Degradation on the Divestment Time of the Redundant Units of Engines in the Fleets

In order to invest in the economic use of associated gas for power generation using gas turbines; a model would be required to ascertain the best divestment time for the redundant units of engines and also to estimate the effect of gas turbine degradation on the divestment time. This model would be a very useful decision-making tool in guiding investors in the economic use associated gas for power generation using gas turbines. When an investor makes the best decision on the timing of the divestment and the exact unit(s) of engines to divest, he gets far better techno-economic return that would worth billions of US Dollars in excess of

what he could have achieved if he has not optimised the divestment time.

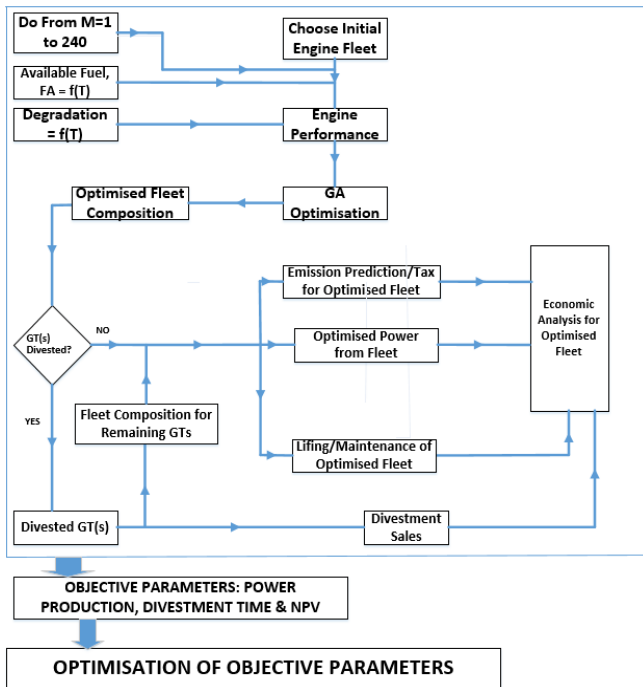

Fig. 3 TERA and Optimisation Methodologies for Associated Gas Utilisation

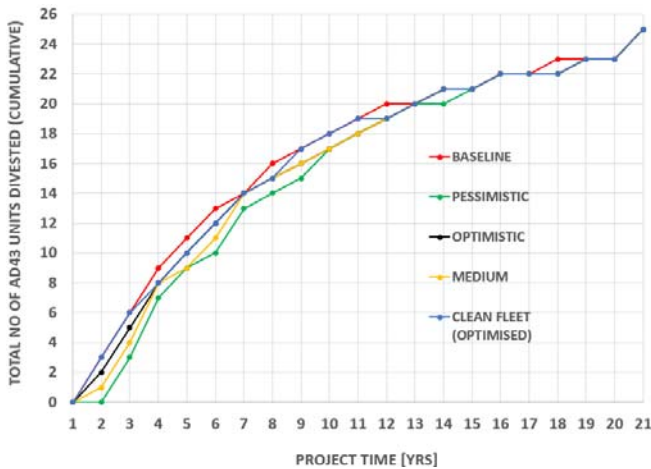

Fig. 4 Optimised Engine Units' Best Divestment Time & the Effect of Gas Turbine Degradation on Divestment Time

Fig. 4 shows the optimised best divestment time and the effect of gas turbine degradation on the divestment time of redundant units of engines in different fleets. As expected, results show that engine degradation extends the divestment time. For example, at the 2nd year of the project; 0, 1, 2, 3, 3 are the respective number of units of engines divested in the pessimistic degraded, medium degraded, optimistic degraded, clean (optimised) and baseline fleets. At the 3rd year, the total (cumulative) number of units of engines that have been divested are 3, 4, 5, 6, 6 for the pessimistic degraded, medium degraded, optimistic degraded, clean (optimised) and baseline

fleets respectively. The effect of degradation in extending the divestment time for the redundant units of engines continued until the 15th year of the project as seen Fig. 4.

For the same turbine entry temperature (TET); the higher the degree of the degradation, the less is the fuel requirements to operate an engine. Since the divestment was prompted by the redundancy of some units of engines due to limited associated gas availability, it therefore means that the fleets with higher degree of degradation will have their units of engines in operation for a longer time as seen in Fig. 4. This prolonging of the period of usage of the engines in the degraded fleets has a positive effect on the economic use of the fleets. It helps in achieving better economic returns from the engines in the fleet; in comparison to a scenario where these same units of engines in these degraded fleets get divested much earlier. Maximal utilisation of an engine is ensured when it is divested at the appropriate time, this helps in increasing the economic productivity of that engine.

B. Gas Turbine Divestment Sales and the Effect of Degradation on the Divestment Sales

The salvage value of a gas turbine engine is the estimated resale value of the gas turbine engine at the expiration of its useful life [5], or its estimated resale value at a time in which the owner feels it techno-economically wise to sell it.

The divestment sale of an engine is greatly determined by its divestment time. The depreciation rate for the clean gas turbine engine is assumed to be 0.0516/annum [6]. 0.0616, 0.0716 and 0.0816/annum are the assumed depreciation rates for the optimistic, medium and pessimistic degraded engines respectively. \$973/KW is used as the engine capital cost [7]. Fig. 5 shows the total divestment sales for all the fleets in the study. As expected, the fleets with higher level of degradation have lower total divestment sales; this is as a result of their prolonged usage time and their higher depreciation rates.

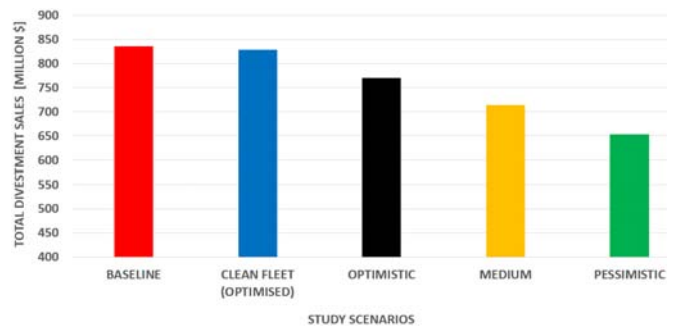

Fig. 5 Total Divestment Sales for the Various Fleets

C. Economic Return (NPV) from Optimised Fleets

Fig. 6 shows the economic return (NPV) for investing in associated gas utilisation. The results shown were taken from a robust model developed for the economic use of associated gas which integrated several technical and economic factors. These factors are capital investment, fleet operations and maintenance cost, emission tax, staff salaries, gas turbine divestment sales, loan repayment and revenue from sold electricity. The gas turbine divestment sales are one of the

sources of revenue in this project.

It is necessary to state that the contents of this paper are based on a research carried out by the author [8].

IV. CONCLUSION

Associated gas is being wasted to flaring in many countries. In order to invest in the economic use of associated gas for power generation using gas turbines; a model would be required to ascertain the best divestment time for the redundant units of engines and to evaluate the effect of gas turbine degradation on the divestment time. This model would serve as a very useful techno-economic decision-making guide to associated gas investors.

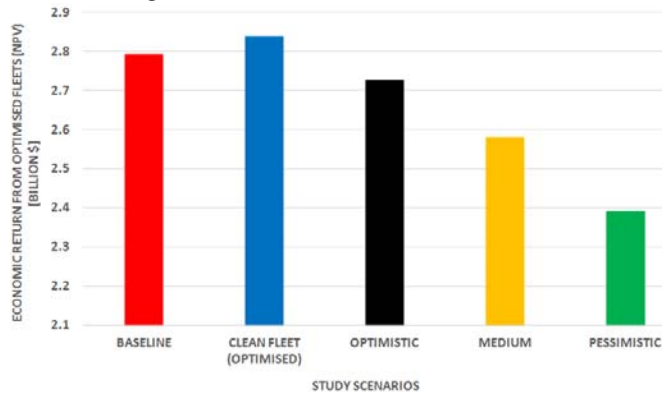

Fig. 6 Economic Return (NPV) for the Various Optimised Fleets

A MATLAB Genetic Algorithm code has been successfully developed, it was used to optimise the best divestment time for the redundant units of engines and also evaluate the effect of degradation on divestment time. As expected, results of the optimisation show that engine degradation extends the divestment time of the redundant units of engines in the various fleets. For example, at the 2nd year of the project; 0, 1, 2, 3, 3 are the respective number of units of engines divested in the pessimistic degraded, medium degraded, optimistic degraded, clean (optimised) and baseline fleets of the engine.

This research has successfully developed a model for evaluating the best divestment time for the redundant units of engines and for estimating the effect of gas turbine degradation on the divestment time. This model serves as a guide for investors who would want to invest in the economic utilisation of associated gas using gas turbines. The results of the optimised divestment times for the degraded fleets are very useful for associated gas investment planning, and it is a contribution to knowledge.

APPENDIX

A. Schematics of the AD43 Engine



Fig. 7 Schematics of the AD43 engine

Fig. 7 shows the schematic representation of the AD43 engine. The components of the engine are intake, low pressure compressor (LPC), high pressure compressor (HPC), burner, high pressure turbine (HPT), low pressure turbine (LPT), and exhaust.

B. Genetic Algorithm Optimisation Flow Chart

TET1, TET2 ... TETn in the chart refer to the various TETs of the units of engines in the fleet.

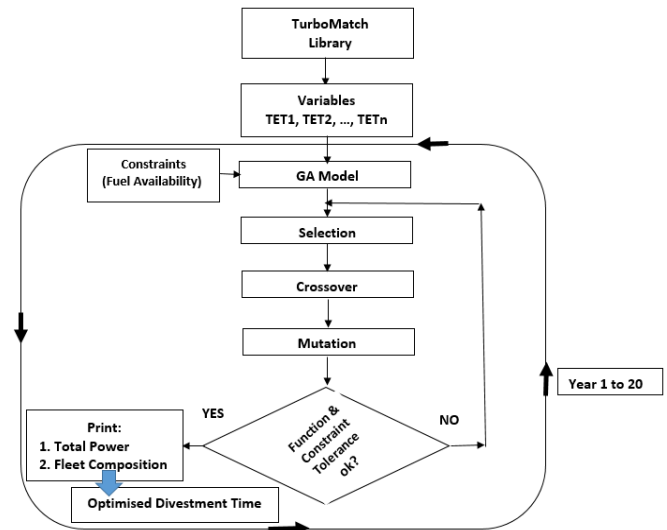

Fig. 8 Genetic Algorithm Optimisation Flow Chart

C. Off-Design Performance of the Study Engine

1) Graph of TET (in Kelvin) against Power Output (MW – Mega Watts) at Various Levels of Degradation (in Percentage)

Fig. 9 that the variation between the TET and power output of the AD43 engine at clean mode and at various levels of degradation.

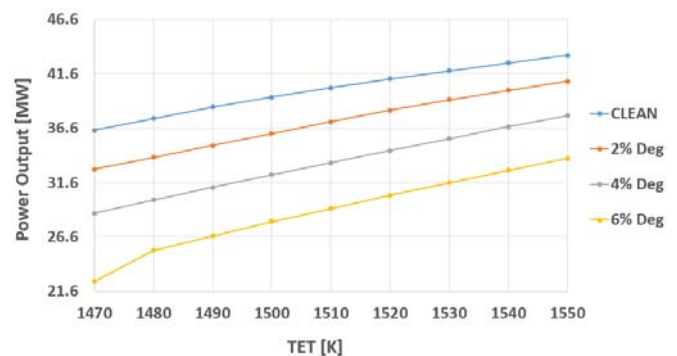

Fig. 9 TET (in K) against Power Output (in MW)

2) Graph of TET against Thermal Efficiency

Shown in Fig. 10 is the variation between the TET and thermal efficiency of the AD43 engine at clean mode and at various levels of degradation.

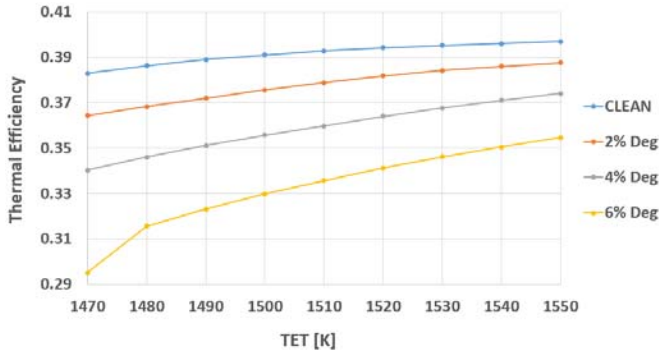

Fig. 10 TET (in K) against Thermal Efficiency

D. Optimised Fleet Composition – Graph of Project Time (in Years) against Annual Number of Clean AD43 Units in the Fleet and Their TETs (in Kelvin)

Fig. 11 gives the details about the units of engines in the fleet (clean) for each year of the project; it shows the optimised operating TETs of the various units of engines.

E. Total Energy from Optimised Fleets

Fig. 12 shows the total energy from the various scenarios considered in the research.

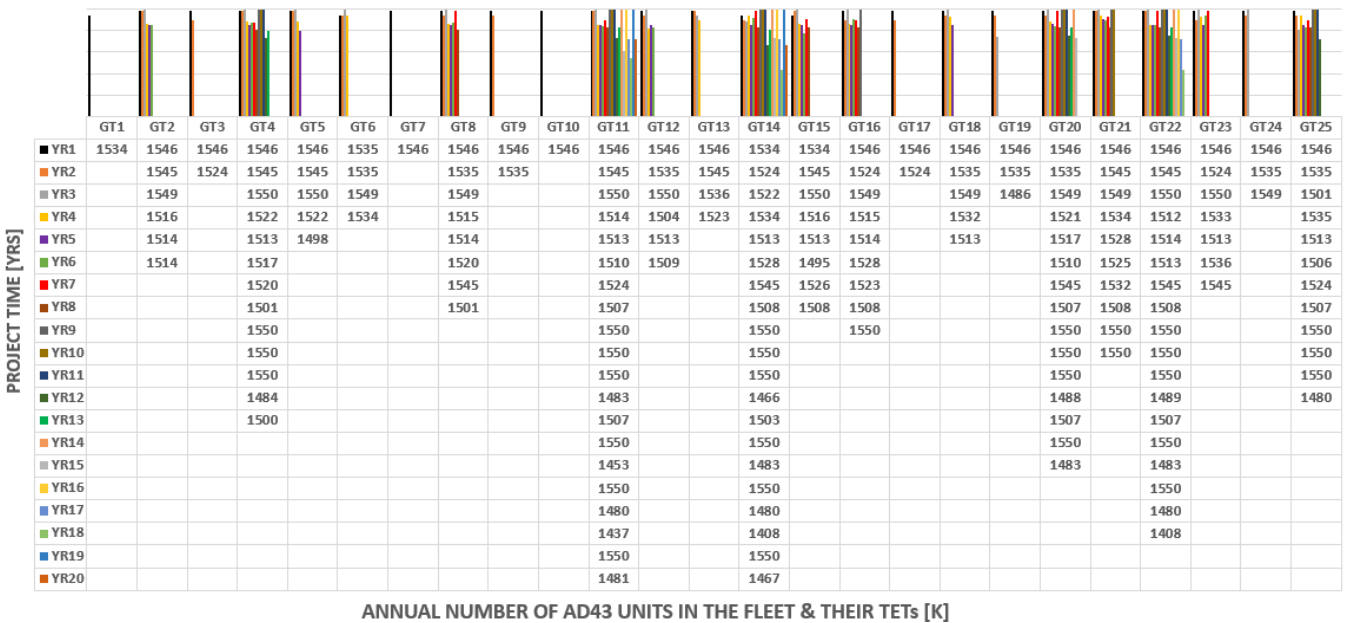

Fig. 11 Project Time against Annual No. of Clean AD43 Units in the Fleet

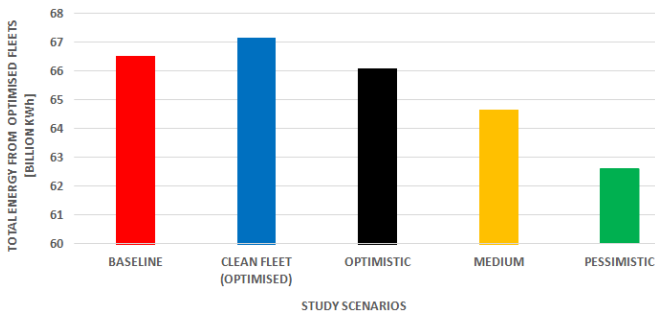

Fig. 12 Total Energy from the Various Study Scenarios

ACKNOWLEDGMENT

M. Obhuo thanks Mr Chika Njoku for his effort at the preliminary stage of the modeling of the optimisation code. The assistance of Dr Dawid Bosak in starting and perfecting the optimisation code is much appreciated. The guidance of Dr Allison Isaiah during the research is well acknowledged and appreciated.

REFERENCES

- [1] I. Allison, "Techno-economic evaluation of associated gas usage for gas turbine power generation in the presence of degradation and resource decline," unpublished, PhD thesis, Cranfield University UK, 2014.
- [2] 2b1st Consulting, "Associated gas", 2012. Available at: <https://www.2b1stconsulting.com/associated-gas/> (Accessed: 17 Dec. 2017)
- [3] J. Kearns et al., "Flaring and venting in the oil and gas exploration and production industry: an overview of purpose, quantities, issues, practices and trends". International Association of Oil & Gas Producers, 2000. Available at: <https://2ch417pds.files.wordpress.com/2014/04/flaring-venting-in-the-oil-gas-exploration-production-industry.pdf> (Accessed: 19 February 2018).
- [4] B. N. Anosike, "Technoeconomic evaluation of flared natural gas reduction and energy recovery using gas-to-wire scheme," unpublished, PhD thesis, Cranfield University UK, 2013.
- [5] Accounting Tools Incorporation, "Salvage value," 2017. Available at: <https://www.accountingtools.com/articles/what-is-salvage-value.html> (Accessed: 22 January 2018).
- [6] Bureau of Economic Analysis – United States (2003), "BEA depreciation estimates," pp. 262-265, 1979. Available at: http://www.bea.gov/national/pdf/fixedassets/BEA_depreciation_2013.pdf
- [7] A. E. Ogiriki, "Effects of environmental factors on gas turbine engine creep life and performance," unpublished, PhD thesis, Cranfield University UK, 2015.
- [8] M. Obhuo, "Techno-economic and environmental risk assessment of

gas turbines for use with flared associated gases," unpublished, PhD thesis, Cranfield University UK, 2018.

- [9] Anosike, N., El-Suleiman, A., and Pilidis, P., (2016), Associated gas utilization using gas turbine engine, performance implication – Nigerian case study. *Energy and Power Engineering*, 8, 137-145.

Mafel Obhuo obtained a Bachelor of Technology degree in Mechanical Engineering in 2010 from the Rivers State University, Port Harcourt, Nigeria. He obtained his MSc and PhD degrees in thermal power (gas turbines) in 2013 and 2018 respectively from Cranfield University, Bedfordshire, MK43 0AL UK.

He is currently a lecturer and the coordinator (the head), Department of Mechanical Engineering, Nigeria Maritime University, Okerenkoko, Delta State, Nigeria.

Dr Obhuo was a student Member of the American Society of Mechanical Engineers (ASME) UK and the Institute of Diesel and Gas Turbine Engineers (IDGTE) UK. He is a Graduate Member of the Nigerian Society of Engineers (NSE) Nigeria.

Dodeye I. Igbong obtained a Bachelor degree in Mechanical Engineering in 2008 from the Cross River University of Technology, Calabar, Nigeria. He obtained his MSc in Process System Engineering in 2010 and PhD in gas turbine propulsion in 2018, both from Cranfield University, Bedfordshire, MK43 0AL UK.

He is currently a lecturer, Department of Mechanical Engineering, Cross River University of Technology, Calabar, Cross River State, Nigeria.

Duabari S. Aziaka obtained a Bachelor of Technology degree in Mechanical Engineering in 2007 from the Rivers State University, Port Harcourt, Nigeria. He obtained his MSc and PhD degrees in thermal power (gas turbines) in 2014 and 2019 respectively from Cranfield University, Bedfordshire, MK43 0AL UK.

He is a lecturer in the Department of Mechanical Engineering, Kenule-Saro Wiwa Polytechnic, Bori, Rivers State, Nigeria.

Dr Aziaka is a Member of various national and international professional bodies. He is a Member of the following; American Society of Mechanical Engineering (ASME) USA, Institute of Diesel and Gas Turbine Engineers (IDGTE) UK, Nigerian Society of Engineers (NSE) Nigeria. He is a Chartered Engineer, registered with the Council for the Regulation of Engineering in Nigeria (COREN). He has worked with the Mobil Oil Nigeria Plc, Nigeria. He has published several articles in both national and international reputable journals.

Pericles Pilidis obtained his PhD degree in gas turbine engineering in 1983 from Glasgow University, UK.

His first employment was with the British Caledonian group in the gas turbine overhaul business. He joined Cranfield University, Bedfordshire UK in 1986 as a Lecturer and was promoted to the director of the thermal power Masters course and the head of the gas turbine engineering group. In 2006 he was appointed head of the power and propulsion department. Throughout his career at Cranfield, he has supervised 150+ postgraduate students. He has authored/co-authored many scholarly articles in journals and conference papers.

Prof. Pilidis is a Fellow of the Royal Aeronautical Society, Fellow of the Higher Education Academy and was Chairman of the ASME Cycle Innovations. He has acted as a consultant to several organizations and his active contributions have resulted in many international honours.