

Voltage Sag Characteristics during Symmetrical and Asymmetrical Faults

Ioannis Binas, Marios Moschakis

Abstract—Electrical faults in transmission and distribution networks can have great impact on the electrical equipment used. Fault effects depend on the characteristics of the fault as well as the network itself. It is important to anticipate the network's behavior during faults when planning a new equipment installation, as well as troubleshooting. Moreover, working backwards, we could be able to estimate the characteristics of the fault when checking the perceived effects. Different transformer winding connections dominantly used in the Greek power transfer and distribution networks and the effects of 1-phase to neutral, phase-to-phase, 2-phases to neutral and 3-phase faults on different locations of the network were simulated in order to present voltage sag characteristics. The study was performed on a generic network with three steps down transformers on two voltage level buses (one 150 kV/20 kV transformer and two 20 kV/0.4 kV). We found that during faults, there are significant changes both on voltage magnitudes and on phase angles. The simulations and short-circuit analysis were performed using the PSCAD simulation package. This paper presents voltage characteristics calculated for the simulated network, with different approaches on the transformer winding connections during symmetrical and asymmetrical faults on various locations.

Keywords—Phase angle shift, power quality, transformer winding connections, voltage sag propagation.

I. INTRODUCTION

VOLTAGE sags (or dips) are sudden drops of the root mean square (rms) voltage with a typical duration that can range between few cycles of the power system frequency and a few seconds. Usually, they are characterized by the remaining magnitude. The most severe sags are caused by short-circuits in the power transmission or distribution system. Their effect on sensitive equipment, such as adjustable speed drives or control devices, can be as important as voltage interruptions, which are more severe, but less frequent [1], [2].

Voltage sags are mainly caused by symmetrical or asymmetrical faults in the power transmission or distribution systems. A large number of buses may experience the voltage sags when the faults occur in the transmission system. Even though some of these buses are considered electrically far away from the original position of the fault, they still experience the voltage sag. Most transmission systems' topology is in the form of meshed networks and they deliver most of the power they transfer at high voltage levels. On the other hand, faults in a distribution system are usually the cause for voltage sags only on local buses [3].

Voltage sag spreading through different transformer winding connections results in a different experience of the

fault on the other winding side of transformers. This matter is discussed in detail in [1]-[5]. This sag spreading is referred as voltage sag propagation and points to the flow of the sags from the higher to the lower voltage level. Due to the impedance of the step-down transformers, the reverse direction of the propagation is not significant [3].

The performance of voltage sags at the different voltage level can be assessed by either monitoring or a stochastic approach. The performance at the equipment's terminals may alter again from that at the upstream buses due to the winding connections of the service transformers [3].

This study is presented using transformer winding connections commonly used in Greek distribution networks taking into account simulation results of faults and measurements in different buses and nodes across the network (numbered 1 to 5), as shown in Fig. 1.

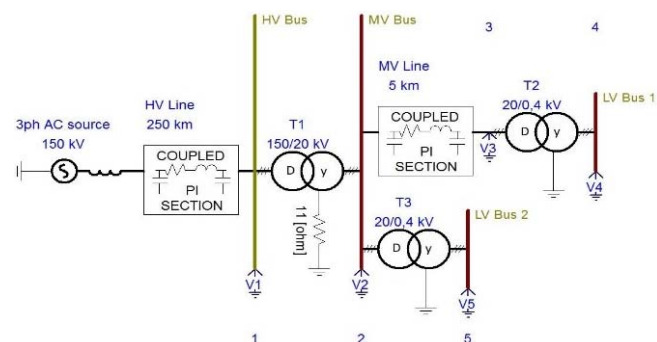

Fig. 1 Proposed model of the distribution network used for this study

II. VECTOR GROUPS AND CONNECTIONS

The terminology for vector groups and winding connections of power transformers along with common (or preferred) connections are described in international standards, such as IEC [6] or IEEE [7], [8]. IEC standards and transformer manufacturers propose the term “Vector group”. It refers to the way in which the windings are connected and the phase position of their respective voltage vectors. A vector group identification consists of:

- 1) Two letters (one capital and one lower-case) for identifying the configuration of phase windings. Winding connections are divided into Delta (D, d), Star or Wye (Y, y), Interconnected star or zigzag (Z, z) and Open or Independent (III, iii) windings [13]. When referring to the High-Voltage (HV) windings, the capital letter is used and a lower-case letter for the Medium-Voltage (MV) and Low-Voltage (LV) windings. The vector group begins with the capital letter.

Marios Moschakis is with the University of Thessaly, Greece (e-mail: mmoschakis@teilar.gr).

- 2) One letter (N, n) which indicates that the neutral of a winding in star or interconnected star is brought out.
- 3) One number, which indicates the phase displacement between the voltages of the windings, having as reference the HV winding. Multiplied by 30° , this number states the angle by which the vector of the LV winding lags that of the HV winding. The angle of any LV winding is expressed by the 'clock notation'. Meaning that the hour is indicated by the winding phasor when the HV winding phasor is at 12 o'clock (a bigger number indicates larger phase lag). Table I presents the common three-phase transformer connections (with no reference to the neutral point of the star-connected windings) according to IEC 60076-1 [14].

As an example, vector group YdN11 indicates that the transformer has a wye-connected HV winding and a delta-connected LV winding with its neutral point brought out. The angle of the LV winding phase voltage lags the HV by 330° (or leads by 30°). Fig. 2 shows the angle difference between the primary and secondary winding of the said Dyn11 transformer with VA, VB and VC representing the three phases on the primary side and Va, Vb and Vc the phases on the secondary side.

Most common criteria for selecting a transformer's vector group are elimination of harmonics, earth fault currents, neutral stabilization and type of application (transmission or distribution system, connection of a generator, power electronic converter, industrial load etc.) [9].

TABLE I
 COMMON CONNECTIONS ACCORDING TO IEC 60076-1

Number	Connections	Number	Connections
0	Yy0, Dd0, Dz0	2	Dd2, Dz2
1	Yd1, Dy1, Yz1	4	Dd4, Dz4
5	Yd5, Dy5, Yz5	7	Yd7, Dy7, Yz7
6	Yy6, Dd6, Dz6	8	Dd8, Dz8
11	Yd11, Dy11, Yz11	10	Dd10, Dz10

III. VOLTAGE SAG CHARACTERISTICS

A voltage sag is defined as a sudden decrease in the rms value of the AC voltage. Remaining voltage takes values between 0.1 p.u. and 0.9 p.u. and typical voltage sags last from 0.5 cycles to 1 min [10]-[13]. Voltage sag duration refers to the time interval between the point-on-wave of sag initiation and recovery [11]-[14]. The magnitude of the voltage sag referred in this paper is the remaining bus voltage during the fault, whereas the angle shift refers to the difference of the respective phase angles between the phase in fault and its healthy reference. Most important characteristics of a voltage sag is its magnitude and its duration and they are used for developing equipment compatibility charts and indices. In addition to these, other characteristics such as unbalanced voltage sags, phase angle shifts, the point on the wave of initiation and recovery, and waveform distortion have been found to influence significantly the equipment's sensitivity to the voltage sags [1].

IV. STUDY CASE

Assessing voltage sags has greater importance for industrial installations, though, in order to have a more accurate assessment, we should not ignore the contribution of faults at the transmission network feeding the distribution network.

For the study's simulations, we specified the network components according to the Hellenic Grid Code (HGC). The studied power system, shown in Fig. 1, consists of the 150 kV equivalent source and impedance, a HV 250 km transmission line, a step-down transformer (T1) 150 kV/20 kV, two step-down transformers (T2 and T3) 20 kV/400 V and a 5 km MV line connecting T2 to the MV bus (T3 is connected directly to the MV bus).

The HGC states that the design and function of a power network by the Network Operator is executed in a manner ensuring that the maximum expected fault current will not exceed 31 kA for the HV (150 kV) network [15]. Accordingly, we calculated the impedance for the 150 kV source equivalent to be equal to 0.0089 H. It is also specified by the HGC that in any MV network, the neutral junction is grounded on the HV/MV substations through an ohmic resistance in order for the earth-fault current to be limited to a maximum of 1000 A [16]. According to this specification, we simulated a resistor between the neutral point and ground connection on transformer T1, with a value of 11 Ohms, which after our simulations, has been effective into keeping the fault current at a maximum of 0.814 kA.

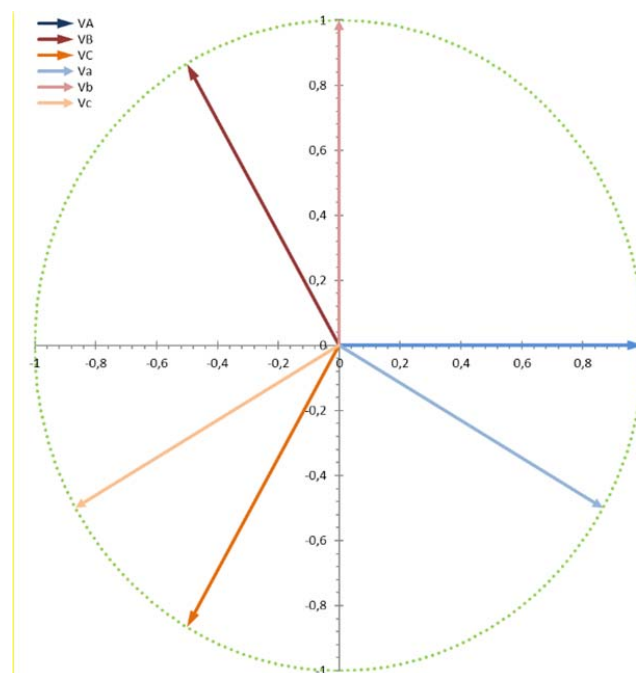

Fig. 2 Phase angle difference between primary and secondary winding in a Dyn11 transformer

We used five discrete points on the network to measure and simulate faults, also shown in Fig. 1 (named 1 to 5) and simulated the four categories of faults (1ph-N, 2ph-N, 2ph, 3ph) on points 1, 3 and 5. We also measured the rms voltage

on all five points, while both voltage magnitude and phase angle measurements were made in the p.u. system. Vector groups Dyn1, Dyn5, Dyn7, and Dyn11 were used for transformers T1 and T2, while transformer T3 remains with the same vector group (Dyn11) for all iterations. Those transformer vector groups are commonly used in Greek power systems and industrial consumer's interconnection with the distribution network.

The analysis of simulation results of voltage magnitude and phase angle shifts for each voltage phase during the faults are presented in the next section. For 1ph-N faults we assume phase A is in fault, for 2ph-N and 2ph, we assume phases B and C. In order to present the findings and to have a common reference, we will be referring to any case measurements in this sequence: *T1 vector group - T2 vector group - Fault point - Fault type - Measurement point*. For example: 1-5-3-1phN-2 refers to T1 vector group Dyn1, T2 vector group Dyn5, fault point is 3, fault type is 1ph-N and the measurements refer to point 2, all as shown in Fig. 1. Moreover, measurements made on the system in fault are compared to measurements made on the same point in the same system in its' healthy status. Thus, all phasor diagrams used in the next section contain six phase voltage vectors in total: VaF, VbF, VcF (the voltage vectors in the faulty system) and VaH, VbH, VcH (the voltage vectors in the same point of the healthy system). Voltage magnitude is always considered 1 p.u. for the healthy system and the phase angle shift refers to the phase angle difference between the respective faulty system phase and its' healthy counterpart.

TABLE II

CASE CODING EXAMPLES USED FOR REFERENCE IN ITERATIONS EXECUTED					
Case Code	T1 Vector Group	T2 Vector Group	Fault Point	Fault Type	Meas. Point
1-1-1-1PhN-1	Dyn1	Dyn1	1	1PhN	1
1-5-3-2PhN-2	Dyn1	Dyn5	3	2PhN	2
7-11-5-2Ph-4	Dyn7	Dyn11	5	2Ph	4

Using PSCAD simulation package [17] we were able to cover most network characteristics for our simulation except for the different transformer vector groups. The software contains models for Dyn1 and Dyn11 (30° lagging or leading of the primary side) and in order to overcome this, we used phase sequence swaps, introducing 120° phase angle shifts, additional to the 30° of the available connections, resulting into the equivalent of vector groups Dyn5 and Dyn7.

V. ANALYSIS OF RESULTS

The first thing we can notice is that when a 1ph-N fault occurs on one side of the transformer, the other side experiences a sag in two phases. In Fig. 3 we simulated a 1ph-N fault on the HV side of T1, which drops phase A to zero while phases B and C reach 1.43 p.u. on point 1. On the other side of T1, on point 2, it is perceived as a 2ph fault, with phases A and B dropping to 0.82 p.u., whereas on the LV side of T2 it is again perceived as a 1ph fault with phase B dropping to 0.75 p.u. on point 4.

TABLE III

SAG CHARACTERISTICS FOR CASE 1-1-1-1PHN						
Meas. Point	VaF p.u.	VbF p.u.	VcF p.u.	Angle Shift A	Angle Shift B	Angle Shift C
1 (HV)	0	1.42	1.42	-77.48°	-22.08°	22.51°
2 (MV)	0.82	0.82	1	-7.48°	7.92°	-0.02°
3 (MV)	0.82	0.82	1	-7.48°	7.92°	-0.02°
4 (LV)	0.94	0.75	0.95	-6.63°	0.36°	6.71°
5 (LV)	0.75	0.95	0.94	0.36°	6.71°	-6.63°

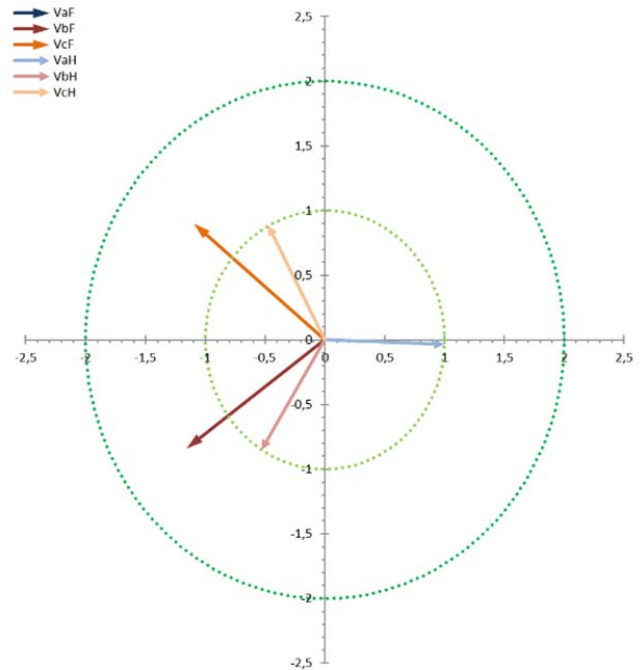

(a)

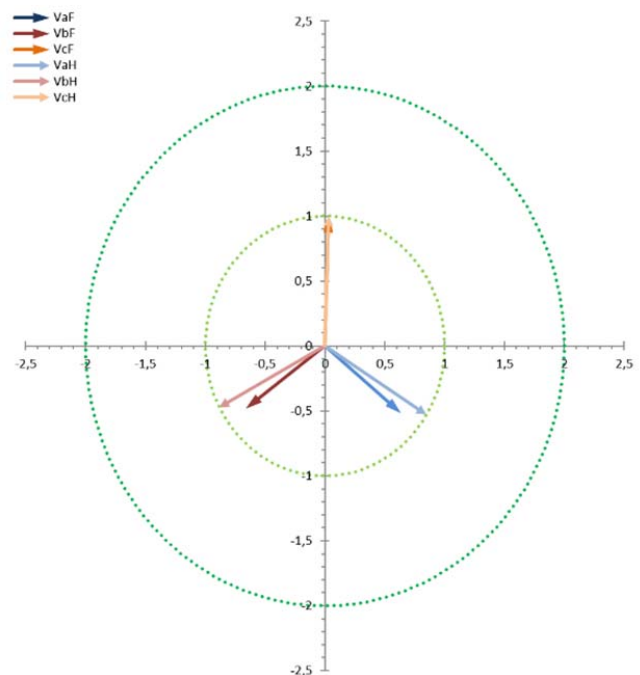

(b)

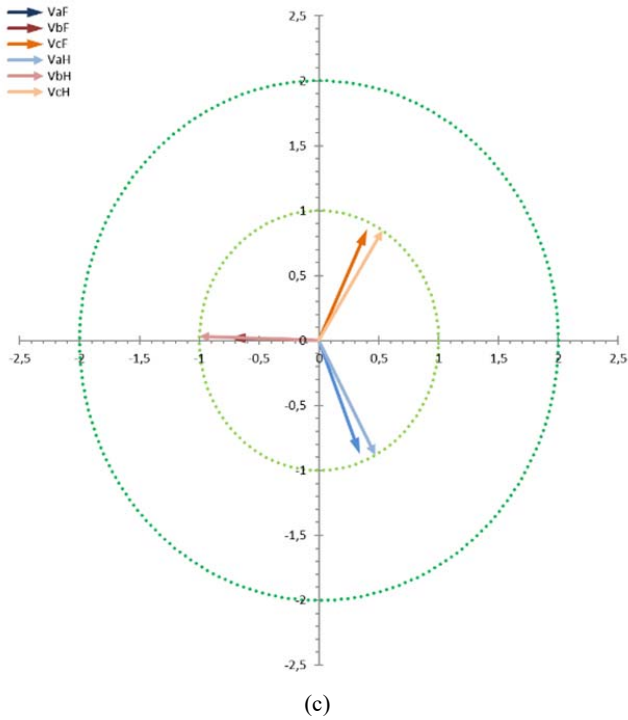

Fig. 3 Cases (a) 1-1-1-phN-1, (b) 1-1-1-phN-2, (c) 1-1-1-phN-4

TABLE V
SAG CHARACTERISTICS FOR CASE 1-1-3-1PHN

Meas. Point	VaF p.u.	VbF p.u.	VcF p.u.	Angle Shift A	Angle Shift B	Angle Shift C
1 (HV)	0.93	1	0.99	-1.51°	0°	-4.28°
2 (MV)	0.27	1.26	1.71	42.97°	-37.6°	12.77°
3 (MV)	0	1.38	1.69	-27.26°	-34.29°	17.55°
4 (LV)	0.97	0.8	1	-12.41°	-4.3°	0°
5 (LV)	0.88	1	1	-3.91°	0°	-7.99°

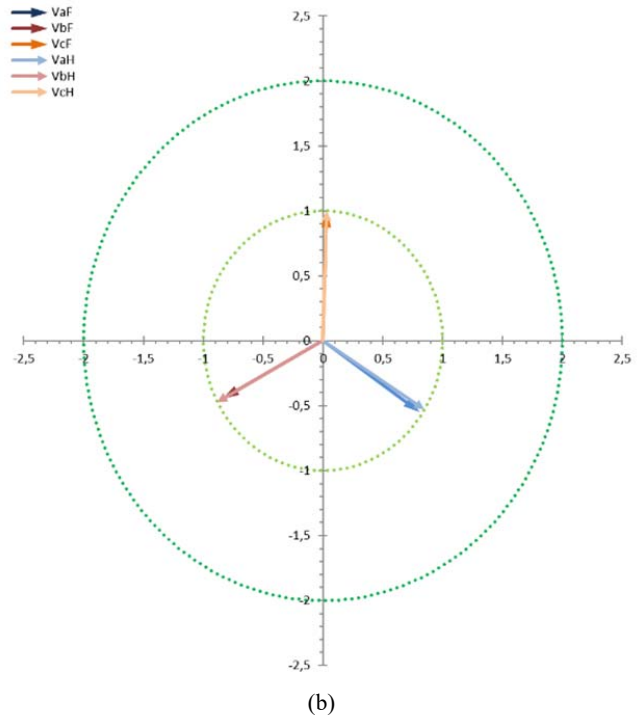
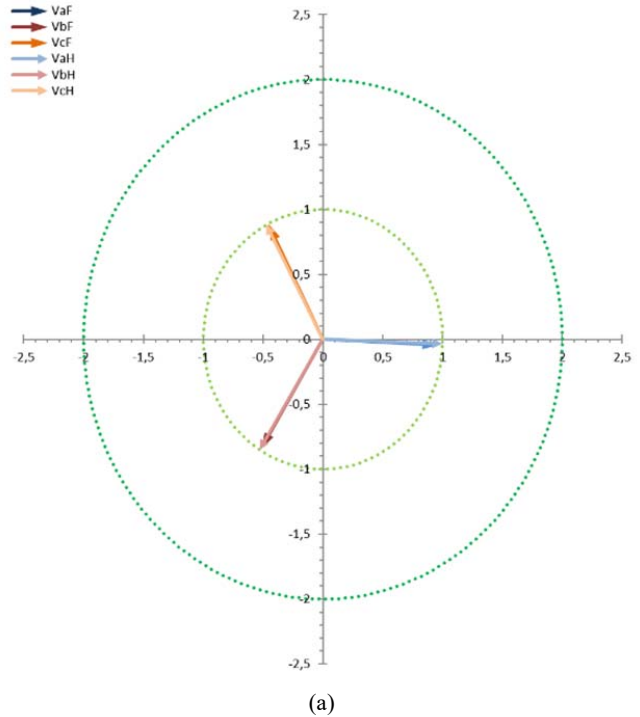

TABLE IV
SAG CHARACTERISTICS FOR CASE 1-1-5-1PHN

Meas. Point	VaF p.u.	VbF p.u.	VcF p.u.	Angle Shift A	Angle Shift B	Angle Shift C
1 (HV)	0.97	0.99	1	-0.66°	0.5°	-0.8°
2 (MV)	0.98	0.95	1	-2.33°	0.04°	0°
3 (MV)	0.98	0.95	1	-2.33°	0.04°	0°
4 (LV)	1	0.95	0.98	-1.53°	-1.56°	0.8°
5 (LV)	0.59	0.98	1	-53.57°	0.8°	-1.53°

We notice that the closer is the point of measurement to the point of fault, the bigger is the angle displacement, as for this case we can see 22° for each phase on point 1, 7.5° for each phase on point 2 and 6° per phase on point 4. Point 5 shows the same measurements as 4 with the difference of the phase sequence due to the different vector groups of T2 (Dyn1) and T3 (Dyn11).

In the opposite case, as shown in Fig. 4, when we simulated a 1ph-N fault on point 5 (LV side of T3), there were both a severe voltage sag (down to 0.59 p.u.) and phase angle shift (-53.57°) on phase A. These were local only to that point, as the differences on the phase vectors on other points of the network (with reference to the healthy circuit) were negligible. On the LV side of T2 the fault was perceived as a 0.95 p.u. sag with -1.5° phase angle shift. On the MV bus, as a 0.95 p.u. sag with 0° phase angle shift on phase B and 0.98 p.u. sag with -2.33° phase angle shift on phase A. Finally, on the HV side of T1, the difference was practically non-existent with 0.97 p.u. sag and -0.66° phase angle shift on phase A.

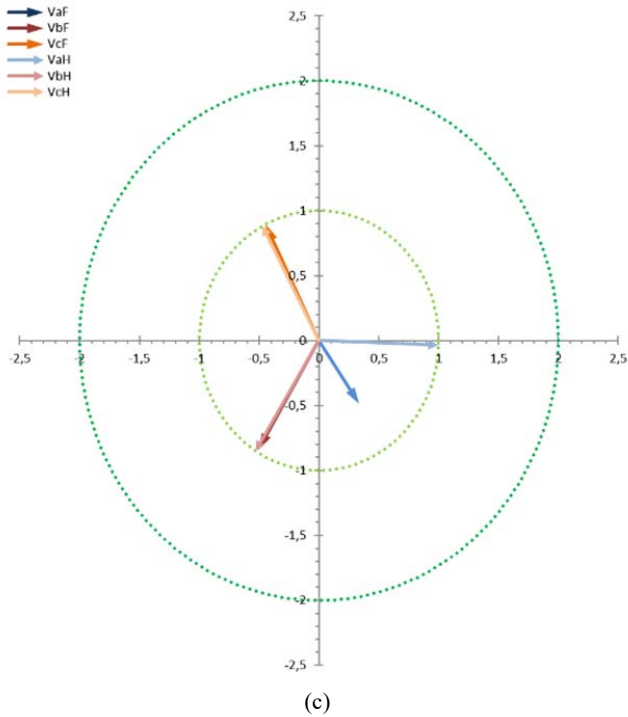

Fig. 4 Cases (a) 1-1-5-1phN-1, (b) 1-1-5-1phN-2, (c) 1-1-5-1phN-5

When we simulated a 1ph-N fault on the MV segment, as shown on Fig. 5, (almost no differences in the measurements, whether the fault was before or after the MV line) the HV side of T1 did not perceive a severe sag. We measured 0.93 p.u. magnitude and -1.51° angle shift for phase A and 0.99 p.u. magnitude and -4.28° angle shift for phase C. The situation was different for the MV and LV segment of the network. For the MV bus, phase A was of course short-circuited, phases B and C experienced a swell with 1.38 p.u. and 1.69 p.u. respectively and a -34.29° and 17.5° angle shift. For the LV network segment, even though there were similarities on the measurements taken on the LV side of T2 and T3, there were differences as well. The different vector groups impose a kind of rotation between phases for the angle shift. Moreover, the MV line itself seems to affect the magnitude of the sags, since we the fault was not so severely experienced on the LV side of T3. Indeed, while on point 4 (LV side of T2) the simulation measures 0.97 p.u. magnitude, -12.41° angle shift for phase A and 0.8 p.u. magnitude, -4.3° angle shift for phase B, on point 5 (LV side of T3) there was a 0.88 p.u. magnitude and -3.91° for phase A while phase C experienced only a -8° angle shift.

Repeating the same procedure accordingly for a 2ph fault for the same vector groups and fault points shows the various results, as shown in Figs. 6-8.

Fig. 6 presents the effects of a phase-to-phase fault on the HV side of T1, as experienced on points 1, 3 and 5. On point 1 there is a 0.5 p.u. voltage magnitude on phases B and C with an angle shift of 300° and 60° respectively. Points 2 and 3, the MV bus, and the MV side of T2 after the MV line show identical behavior. As expected, the 2ph fault on the HV side of T1 is perceived as a 1ph fault on the other side of the transformer, as one phase (C on this instance) drops to zero

whereas the other two magnitudes limit the drop to 0.87 p.u. remaining. On the other side the phase angle shift is significant as the two standing phases shift 30° and -30° (or 330°) respectively. Finally, the LV side of transformers T2 and T3 (points 4 and 5 respectively) experience the fault as a 2ph one with phases B and C dropping to 0.5 p.u.. Phase angle shifts $[60^\circ]$, though the different vector groups of T2 and T3 force the healthy A phase on T2 to not shift its angle, whereas on T3, it is phase B (with 0.5 p.u.) that does not shift angle while phases A and C shift by -60° and 60° respectively.

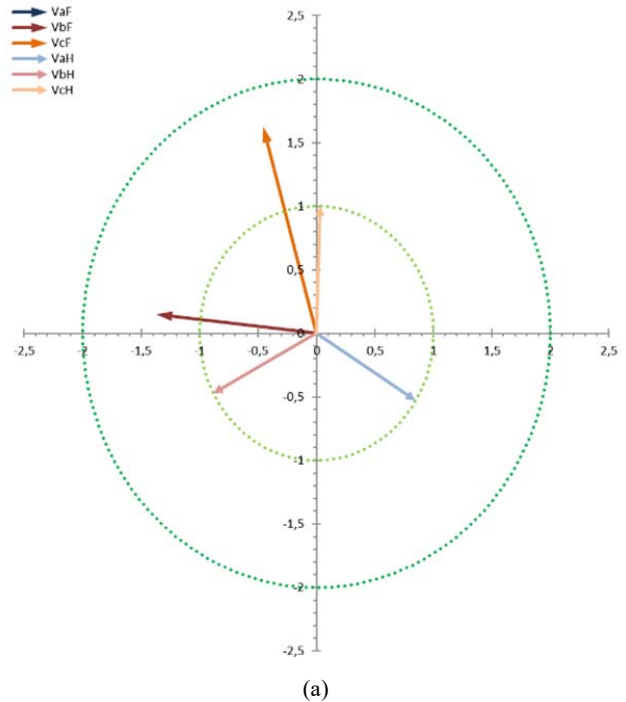

(a)

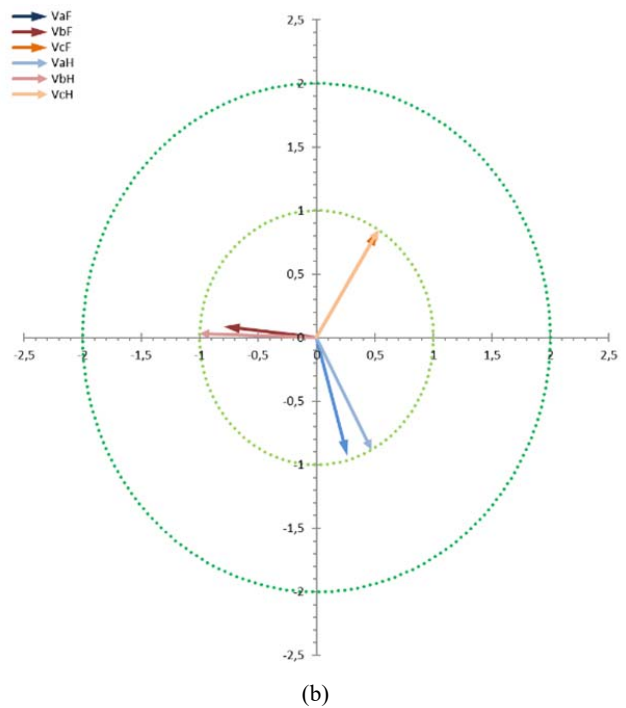

(b)

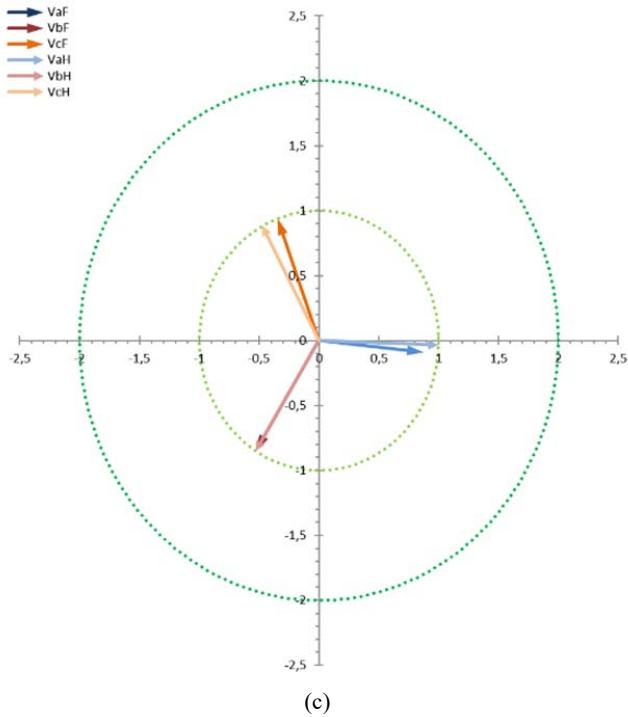

Fig. 5 Cases (a) 1-1-3-1phN-3, (b) 1-1-3-1phN-4, (c) 1-1-3-1phN-5

TABLE VI
 SAG CHARACTERISTICS FOR CASE 1-1-1-2PH

Meas. Point	VaF p.u.	VbF p.u.	VcF p.u.	Angle Shift A	Angle Shift B	Angle Shift C
1 (HV)	1	0.5	0.5	-0.02°	-60.03°	59.97°
2 (MV)	0.87	0.87	0	29.97°	-30.03°	-76.36°
3 (MV)	0.87	0.87	0	29.97°	-30.03°	-76.36°
4 (LV)	1	0.5	0.5	59.97°	-0.02°	-60.02°
5 (LV)	1	0.5	0.5	-0.02°	-60.03°	59.97°

Respectively, Fig. 7 presents the effects of a phase-to-phase fault on the MV side of T2, after the MV line (point 3), as it is experienced on the different points of the network. When this happens, the HV side of T1 experiences a voltage sag on phase B (as expected, it is “seen” as a 1ph fault on the other side) with 0.65 p.u. magnitude remaining and less than 2° angle shift, while phases A and C remain *above* 0.9 p.u. with *less than* |10°| phase shift. On the point of fault, the two faulty phases drop to 0.5 p.u. magnitude with |60°| phase angle shift. Similar to the point of fault but with the MV line in between, point 2 experiences a 2ph fault, though on this case the two phases with the voltage sag, show uneven behavior and 0.67 p.u. and 0.5 p.u. remaining on phases B and C. Similarly, phase angles shift -30° and 20° respectively, thus, creating a greatly unbalanced scenario. The same behavior as points 2 and 3 can be seen in points 5 and 4, which is to be expected, due to the position of the fault and the measuring points. On point 4 phase C drops to *zero* and phases A and B to 0.87 p.u. with |30°| phase angle shift. On the other hand, on point 5, we measure 0.94, 0.37 and 0.83 p.u. magnitude for the three phases respectively with angle shifts of almost |20°| for all of them.

TABLE VII
 SAG CHARACTERISTICS FOR CASE 1-1-3-2PH

Meas. Point	VaF p.u.	VbF p.u.	VcF p.u.	Angle Shift A	Angle Shift B	Angle Shift C
1 (HV)	0.93	0.65	0.92	-9.6°	-1.61°	9.2°
2 (MV)	1	0.67	0.51	0°	-33.13°	22.6°
3 (MV)	1	0.5	0.5	0°	-60°	60°
4 (LV)	0.87	0.87	0	29.98°	-29.98°	-73.34°
5 (LV)	0.94	0.37	0.83	-18.88°	-16.23°	17.49°

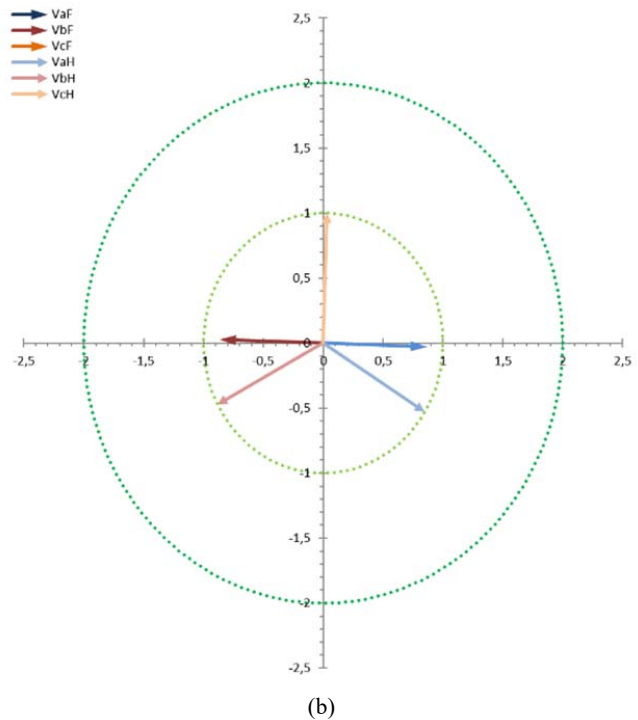
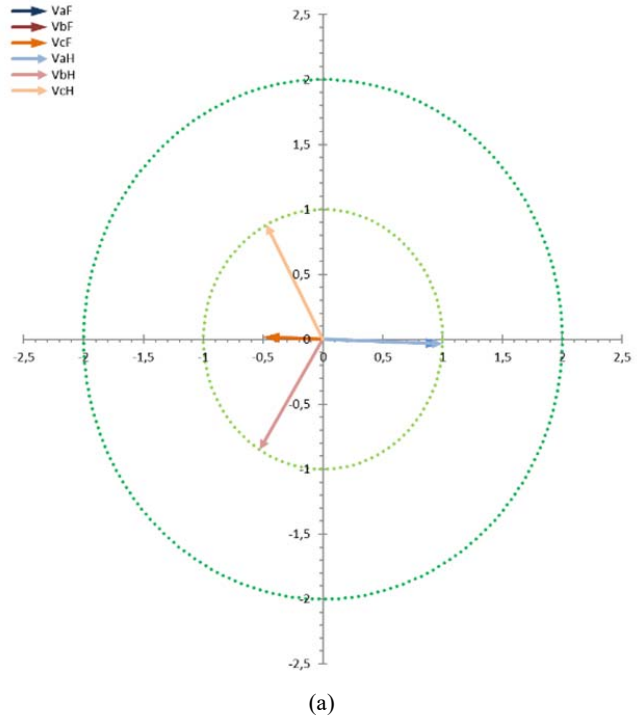

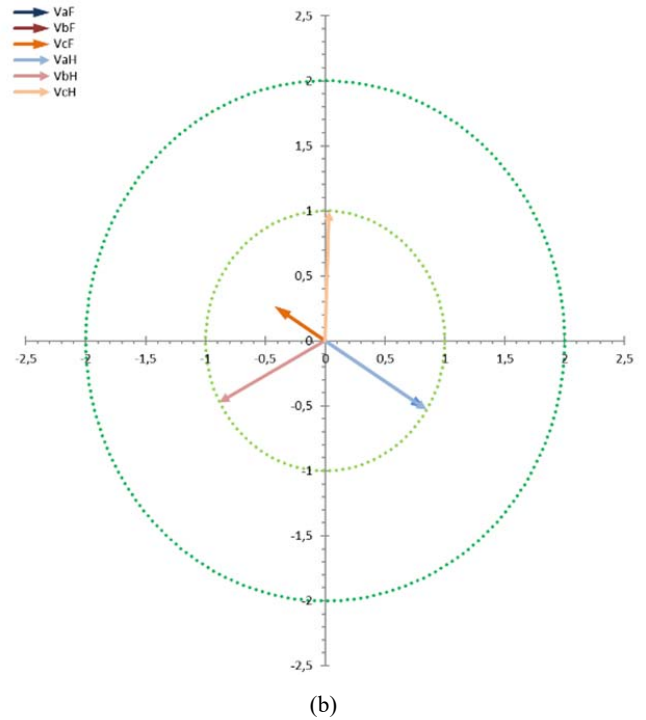
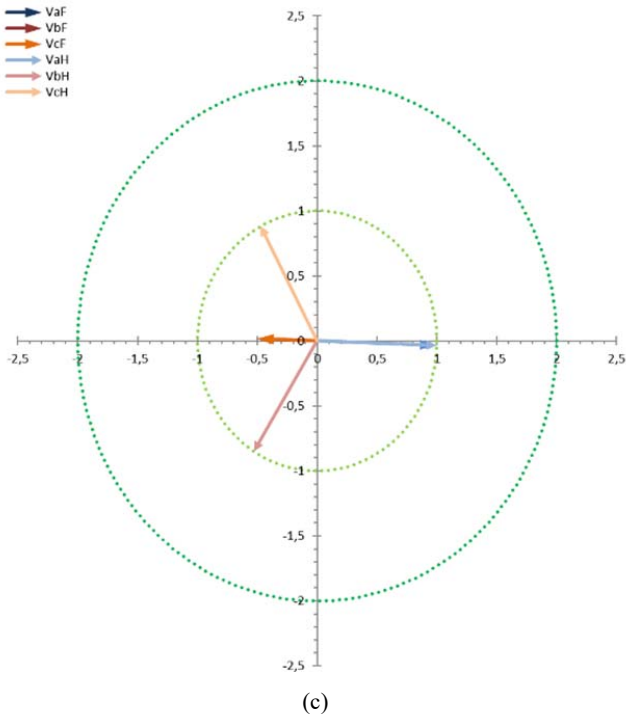
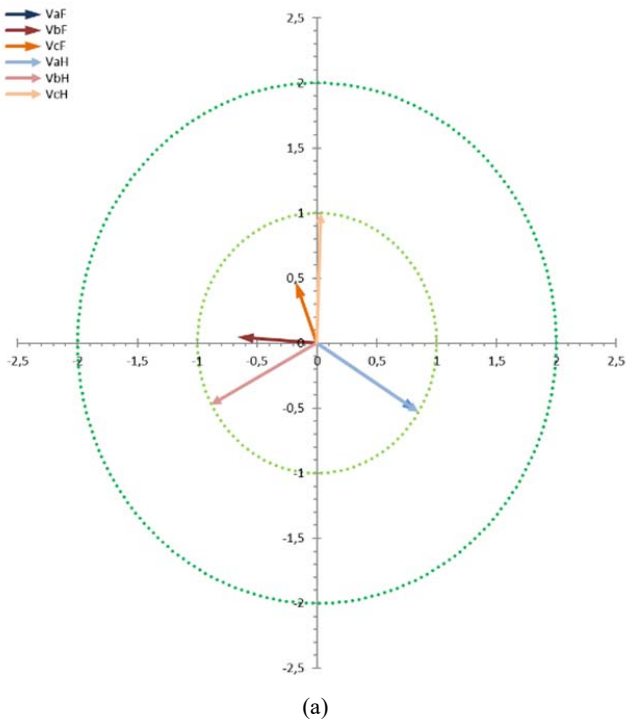
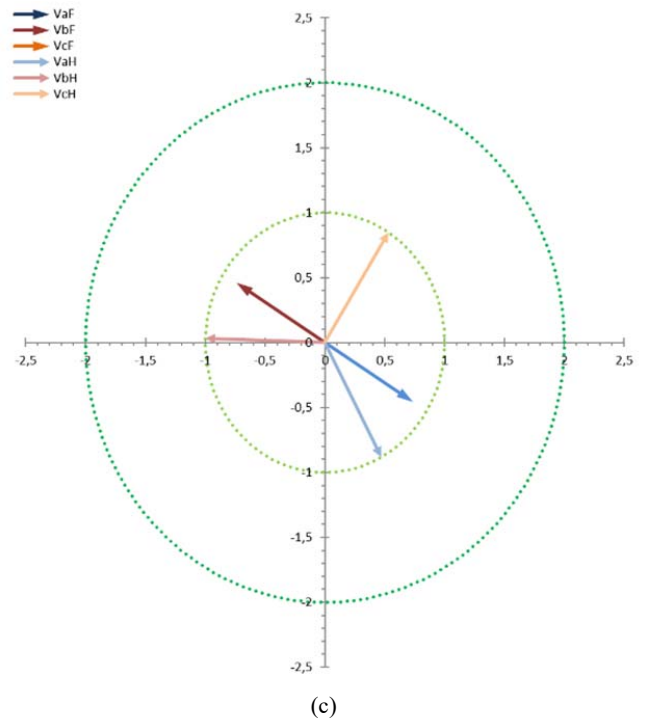

Fig. 6 Cases (a) 1-1-1-2ph-1, (b) 1-1-1-2ph-3, (c) 1-1-1-2ph-5

TABLE VIII
 SAG CHARACTERISTICS FOR CASE 1-1-5-2PH

Meas. Point	VaF p.u.	VbF p.u.	VcF p.u.	Angle Shift A	Angle Shift B	Angle Shift C
1 (HV)	1	0.97	0.96	0°	-1.49°	1.01°
2 (MV)	0.97	0.99	0.91	1.97°	-2.51°	-1.26°
3 (MV)	0.97	0.99	0.91	1.97°	-2.51°	-1.26°
4 (LV)	0.93	1	0.95	1.44°	0°	-3.24°
5 (LV)	1	0.78	0.25	0°	-52.7°	36.82°



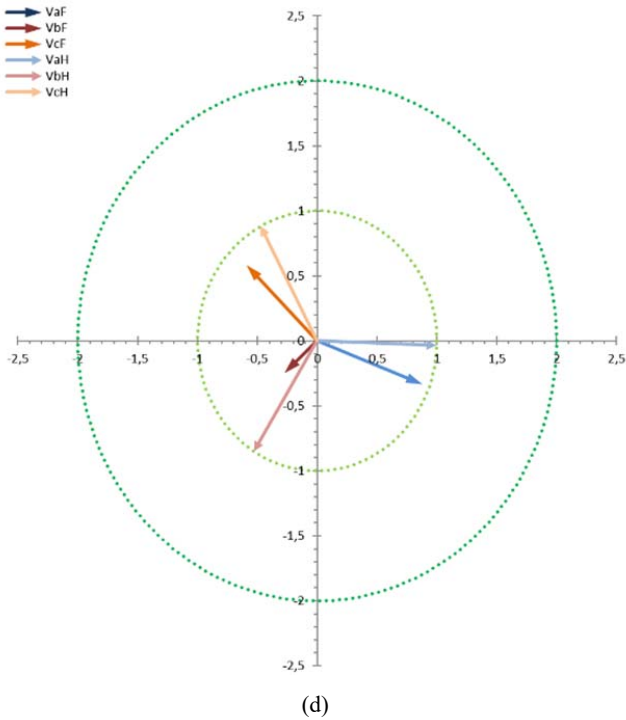

Fig. 7 Cases (a) 1-1-3-2ph-2, (b) 1-1-3-2ph-3, (c) 1-1-3-2ph-4, (d) 1-1-3-2ph-5

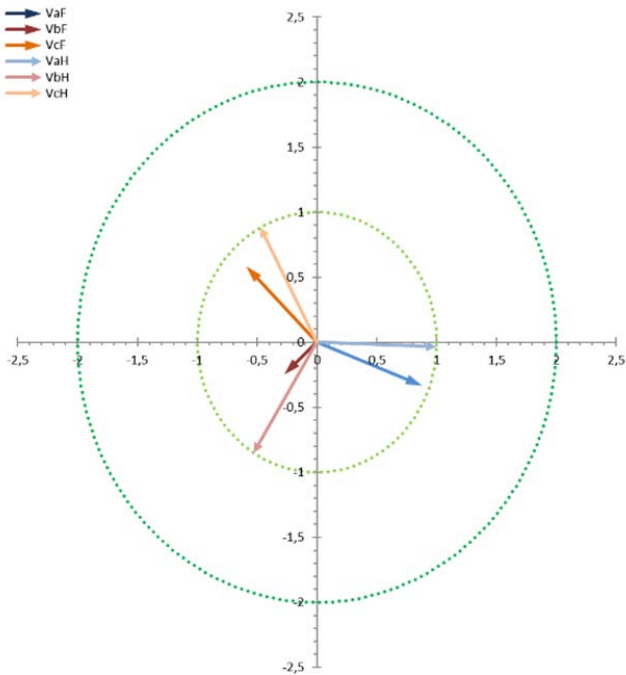

Fig. 8 Case 1-1-5-2ph-5

Differently to the faults in the HV and MV segments of the network, which affect essentially the whole network, a fault occurring on the LV side of any transformer, affects severely only the localized area, while the rest of the network experiences light, almost negligent, effects, same as in case of 1ph faults. Fig. 8 shows the case for the 2ph fault in point 5 and its respective measurements. In this case, a *highly*

asymmetrical fault is experienced, as the faulty phases B and C experience a sag with remaining magnitudes of 0.78 and 0.25 p.u. respectively and similarly different angle shifts with -52° and 37° . All other points of the network retain voltage magnitudes higher than 0.9 p.u. and phase angle shifts less than 3° .

Similarly to a phase-to-phase fault, a 2phase to ground fault creates 2ph sags that are experienced as 1ph sags on the other side of each transformer, though in this case, there is symmetry between the phases in fault. As a result, the two faulty phases drop to the same magnitude (which again depends on the point of fault and the point of measurement), while the phase angle shift is nearly mirrored between the two faulty phases. As such, when the 2ph-N occurs on the MV segment, both HV and LV segments experience a severe sag on one phase while the other two phases remain around 0.9 p.u. with similar and relatively low angle shifts.

Repeating the simulations for a 3ph fault reveals similar results but as expected with a symmetrical profile. A 3ph fault on any point on the network leaves all downstream points on *zero* magnitude, whereas the results defer on the rest of the system, depending on the voltage level segment, and the distance from the point of the fault.

Fig. 9 shows the results for a 3ph fault on the MV side of T2 with measurements on the HV segment, on the MV bus and on the LV side of T3. On the HV bus we notice a 0.65 p.u. voltage magnitude with negligent angle shift (-1.64°) on all phases. On the MV bus we see 0.37 p.u. voltage and a more noticeable phase angle shift of -16.29° . Same results for point 5, except that the phasor is shifted due to the T3's vector group. Points 3 and 4 show voltage magnitude dropping down to *zero*.

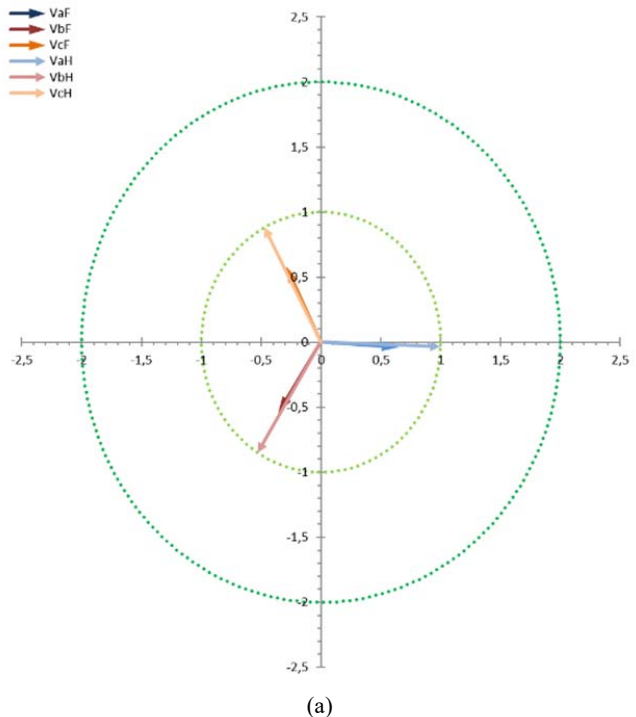

(a)

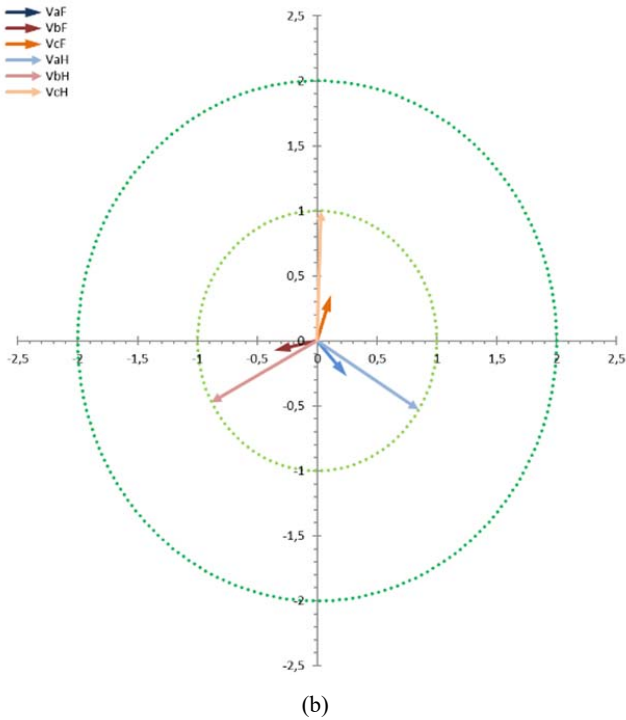

(b)

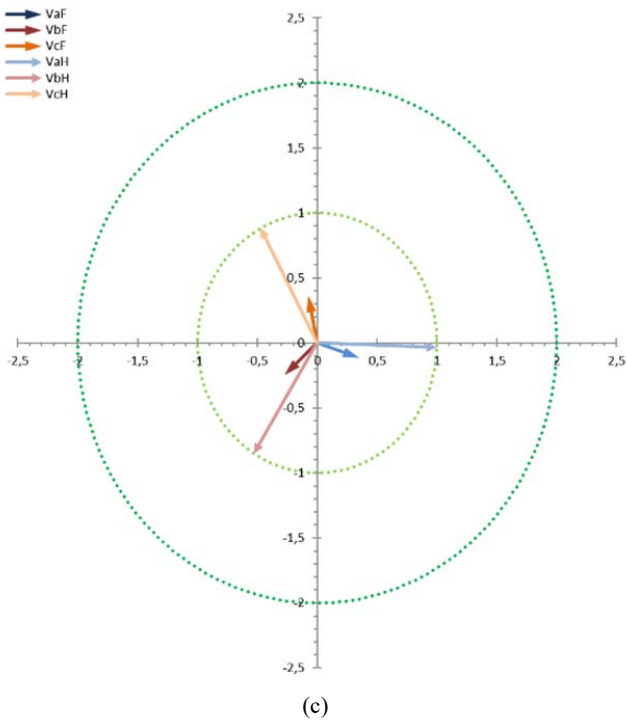

(c)

Fig. 9 Cases (a) 1-1-3-3ph-1, (b) 1-1-3-3ph-2, (c) 1-1-3-3ph-5

TABLE IX
 SAG CHARACTERISTICS FOR CASE 1-1-5-2PH

Meas. Point	VaF p.u.	VbF p.u.	VcF p.u.	Angle Shift A	Angle Shift B	Angle Shift C
1 (HV)	1	0.97	0.96	0°	-1.49°	1.01°
2 (MV)	0.97	0.99	0.91	1.97°	-2.51°	-1.26°
3 (MV)	0.97	0.99	0.91	1.97°	-2.51°	-1.26°
4 (LV)	0.93	1	0.95	1.44°	0°	-3.24°
5 (LV)	1	0.78	0.25	0°	-52.7°	36.82°

Fig. 10 shows respectively the results for the same fault on the LV side of T3. The HV side seems almost unaffected as voltage magnitude stays at 0.96 p.u. with less than -1° angle shift. On the MV segment, both before and after the MV line, the results are the same: Voltage remains above 0.9 p.u. with a -2.29° angle shift, as it is for the LV side of T2. On the point of the fault, voltage magnitude drops to 0.57 p.u. with a severe angle shift, as it reaches $-54,3^\circ$.

Even though 3ph faults are the most *severe* downstream of the fault, since voltage is *interrupted*, statistically, they are those with the less occurrences [5] and they affect network loads on the rest of the network lightly. This is due to transformers' ability to contain voltage sags on the secondary winding and not allow it to travel on the primary side due to their high short-circuit impedance [4].

TABLE X
 SAG CHARACTERISTICS FOR CASE 1-1-3-3PH

Meas. Point	VaF p.u.	VbF p.u.	VcF p.u.	Angle Shift A	Angle Shift B	Angle Shift C
1 (HV)	0.65	0.65	0.65	-1.64°	-1.64°	-1.64°
2 (MV)	0.37	0.37	0.37	-16.29°	-16.29°	-16.29°
3 (MV)	0	0	0	-73.29°	-73.29°	-73.29°
4 (LV)	0	0	0	-73.29°	-73.29°	-73.29°
5 (LV)	0.37	0.37	0.37	-16.29°	-16.29°	-16.29°

TABLE XIII
 SAG CHARACTERISTICS FOR CASE 3PH FAULTS ON THE MV BUS

Meas. Point	VaF p.u.	VbF p.u.	VcF p.u.	Angle Shift A	Angle Shift B	Angle Shift C
1 (HV)	0.65	0.65	0.65	-1.64°	-1.64°	-1.64°
2 (MV)	0.37	0.37	0.37	-16.29°	-16.29°	-16.29°
3 (MV)	0	0	0	-73.29°	-73.29°	-73.29°
4 (LV)	0	0	0	-73.29°	-73.29°	-73.29°
5 (LV)	0.37	0.37	0.37	-16.29°	-16.29°	-16.29°

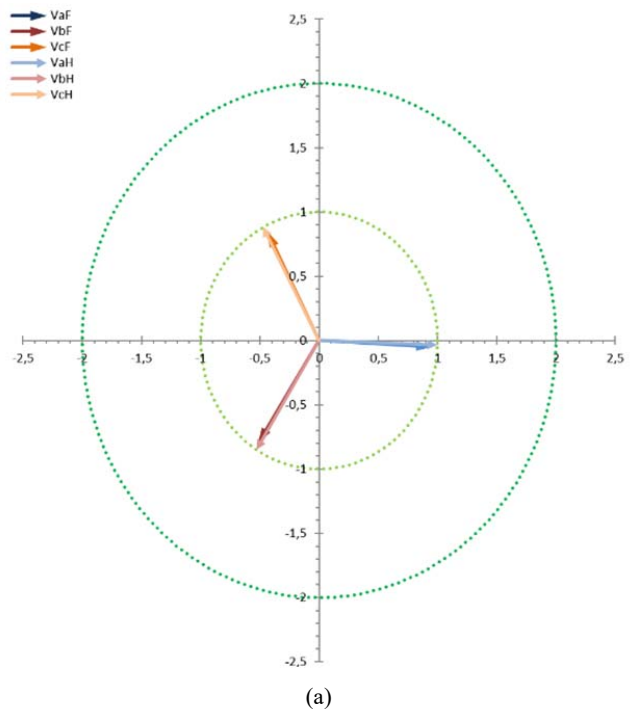

(a)

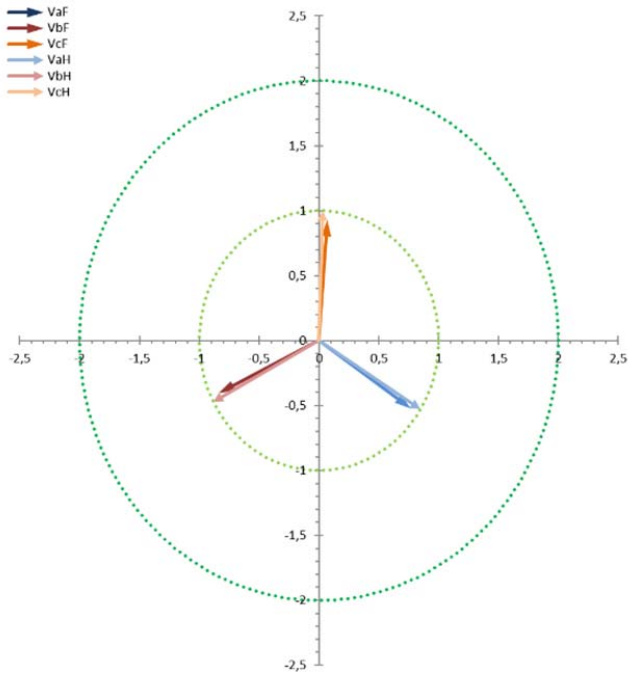

(b)

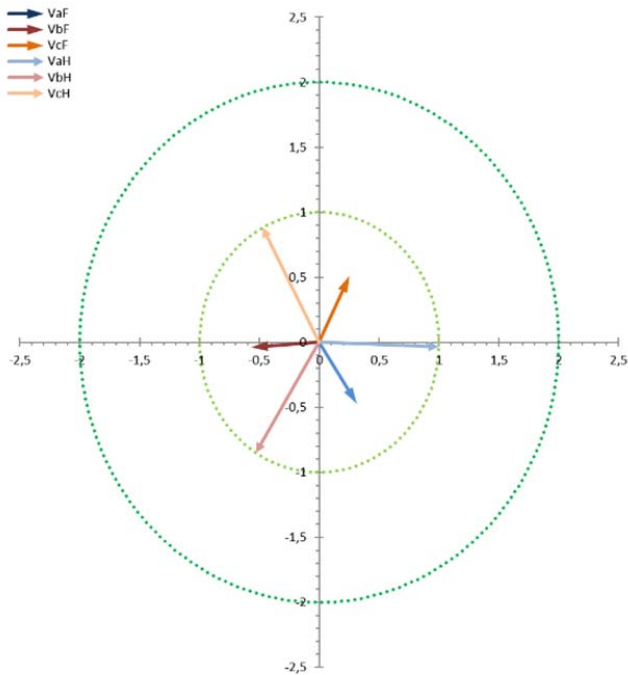

(c)

Fig. 10 Cases (a) 1-1-5-3ph-1, (b) 1-1-5-3ph-2, (c) 1-1-5-3ph-5

There were similar findings when we repeated the simulations for different transformer vector groups, as shown in Figs. 11 and 12. Those present the same fault scenarios as Fig. 6, only this time instead of vector group Dyn1 for transformers T1 and T2, we simulated Dyn5 for T1, Dyn7 for T2 in Fig. 11 and Dyn11 for T1, Dyn5 for T2 in Fig. 12.

While there were no differences on the absolute numbers of voltage magnitude and angle phase shifts, the results rotated

from phase to phase and the sequence changes as the vector group changes.

TABLE XI
 SAG CHARACTERISTICS FOR CASE 5-7-1-2PH

Meas. Point	VaF p.u.	VbF p.u.	VcF p.u.	Angle Shift A	Angle Shift B	Angle Shift C
1 (HV)	1	0.5	0.5	-0.02°	-60.03°	59.97°
2 (MV)	0.87	0	0.87	-30.03°	-76.36°	29.97°
3 (MV)	0.87	0	0.87	-30.03°	-76.36°	29.97°
4 (LV)	1	0.5	0.5	-0.02°	-60.03°	59.97°
5 (LV)	0.5	0.5	1	-60.03°	59.97°	-0.02°

TABLE XII
 SAG CHARACTERISTICS FOR CASE 11-5-1-2PH

Meas. Point	VaF p.u.	VbF p.u.	VcF p.u.	Angle Shift A	Angle Shift B	Angle Shift C
1 (HV)	1	0.5	0.5	-0.02°	-60.03°	59.97°
2 (MV)	0.87	0	0.87	-30.03°	-76.36°	29.97°
3 (MV)	0.87	0	0.87	-30.03°	-76.36°	29.97°
4 (LV)	0.5	0.5	1	-60.03°	59.97°	-0.02°
5 (LV)	0.5	0.5	1	-60.03°	59.97°	-0.02°

After simulating different scenarios while rotating transformer winding connections and fault points, it became apparent that the more transformers installed between the fault and a possible affected point on the network, the less severely perceived was the fault.

Our simulations have shown that faults on the primary side of a step-down transformer affect the downstream installation severely. On the other hand, faults on the secondary side of a step-down transformer do not affect the primary side as much. As depicted on Fig. 10, where a 3ph fault on the LV side of T2 is simulated, measurements on points 1 and 2 (HV and MV segment respectively), indicate that those network points are relatively unaffected by the severe fault on the LV side.

The worst case scenario of a fault affecting the primary side of T1 was that of a 3ph fault on the secondary side (MV segment), where all phases experience a voltage sag with remaining magnitude of 0.65 p.u. and a minor phase angle shift of -1.64°. Faults on the LV segment of the network have practically no effect on the HV line.

As far as absolute values are concerned for measurements on our model network for the different fault types and points simulated, it is interesting to take into account the maximum and minimum absolute values of both voltage magnitude and angle shifts. We noticed that the voltage magnitude could vary from the lowest value of 0 p.u. up to a maximum of 1.71 p.u. whereas angle shifts have varied from 0° up to 100° towards either direction (lagging or leading) on the most severe occasions.

VI. CONCLUSION

This paper presented the results of voltage characteristics in a generic power network during symmetrical and asymmetrical faults. It is clear that during an electrical fault we experience two major events that can affect severely any installed equipment.

First, *voltage magnitude*, depending on the kind of fault and the transformers connected between the fault and the measuring point, can vary significantly. 2ph faults on one side of a transformer are experienced as 1ph sag on the other side. During those sags, phase voltage magnitude can take values from zero to a maximum simulated of 1.71 p.u.

Secondly, *phase angle*, depending again on the kind of fault and the transformers' vector group, can shift in absolute values from zero to 180° (worst case for our simulations was 100°, though it was in cases of where voltage magnitude dropped to zero) which can create great asymmetries.

It is also important how each side of the transformer experiences a specific fault on the other side. A phase-to-ground fault, which drops one phase voltage to zero and swells the other two on one side, is perceived as a minor two-phase voltage sag on the other with some angle shift. Thus, short-circuits, for example on the LV side of one transformer, have almost no effect on another transformer's LV side; even with the transformers being on the same MV bus.

Generally, all faults on the primary side of a step-down transformer, affect the downstream installation severely. On the other hand, faults that occur on the secondary side of a step-down transformer do not affect the primary side as much. Thus, when planning for events in an electrical network, we have to take into account both the possible remaining voltage magnitude (either a sag or a swell) and the phase angle shift that is inserted during the fault, thus creating greater asymmetries.

APPENDIX

A. Line and Transformer Data Used

Table XIV presents data of the two lines, the HV and the MV coupled pi section, while Table XV presents data for the three transformers and the lines that were used for our simulations.

TABLE XIV
 LINE DATA

Parameter	HV Line	MV Line
Line Length	2.5×10^5 m	5×10^3 m
Positive Sequence Resistance	0.097×10^{-3} ohm/m	0.215×10^{-3} ohm/m
Positive Sequence Inductive Reactance	0.391×10^{-3} ohm/m	0.334×10^{-3} ohm/m
Positive Sequence Capacitive Reactance	2000 Mohm*m	2000 Mohm*m
Zero Sequence Resistance	0.497×10^{-3} ohm/m	0.363×10^{-3} ohm/m
Zero Sequence Inductive Reactance	2.349×10^{-3} ohm/m	1.556×10^{-3} ohm/m
Zero Sequence Capacitive Reactance	4000 Mohm*m	4000 Mohm*m

TABLE XV
 TRANSFORMER DATA

Parameter	T1	T2	T3
Apparent Power	50 MVA	1 MVA	1 MVA
Voltage Ratio	150 / 20	20 / 0.4	20 / 0.4
Positive Sequence Leakage Reactance	0.2 p.u.	0.06 p.u.	0.08 p.u.

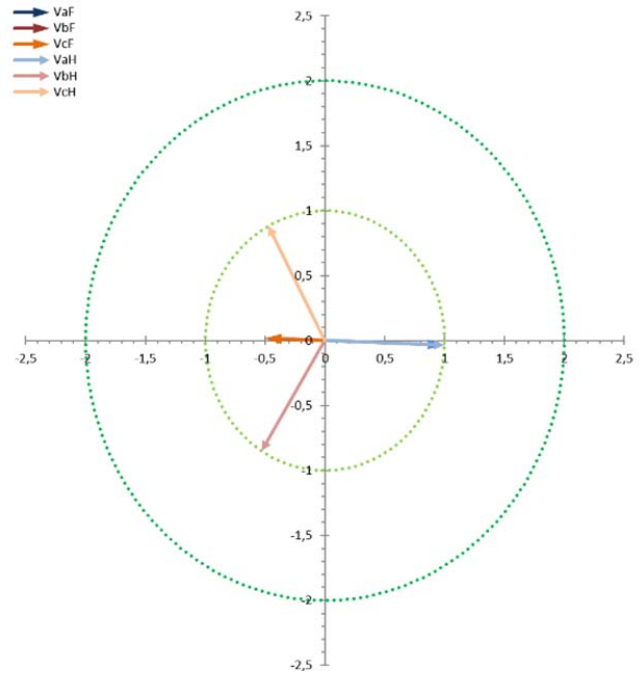

(a)

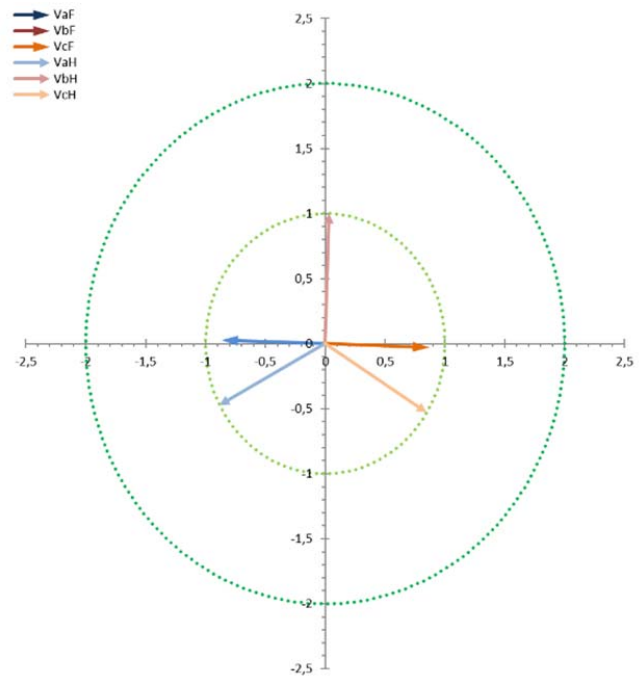

(b)

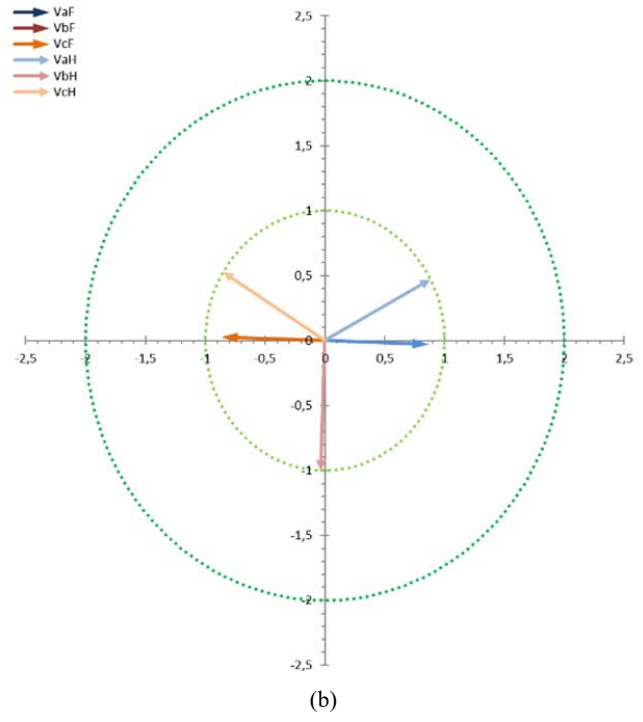
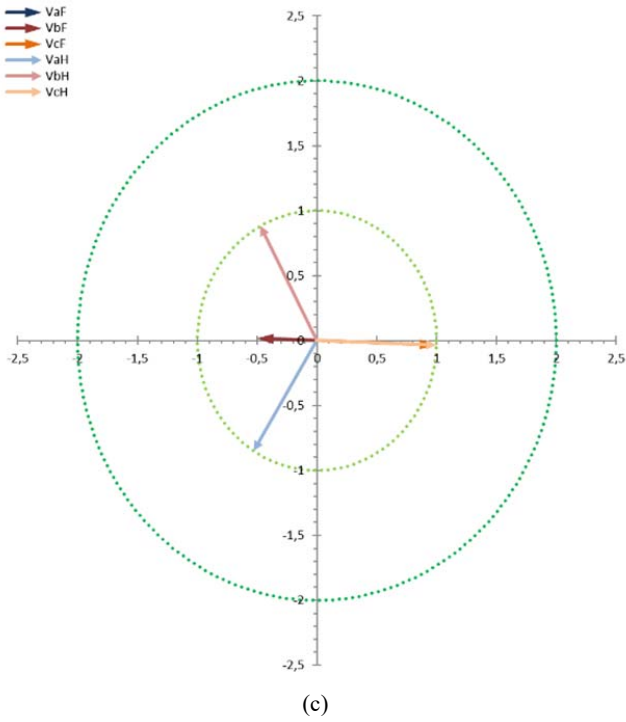

Fig. 11 Cases (a) 5-7-1-2ph-1, (b) 5-7-1-2ph-3, (c) 5-7-1-2ph-5

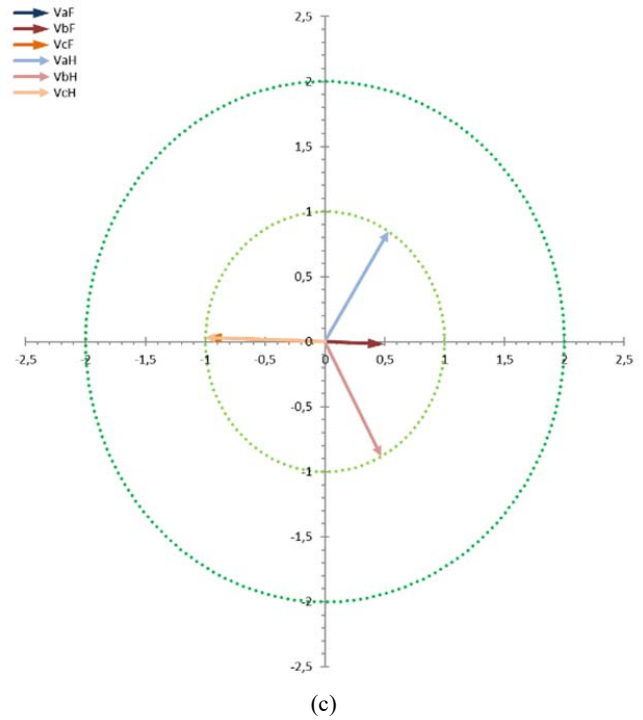
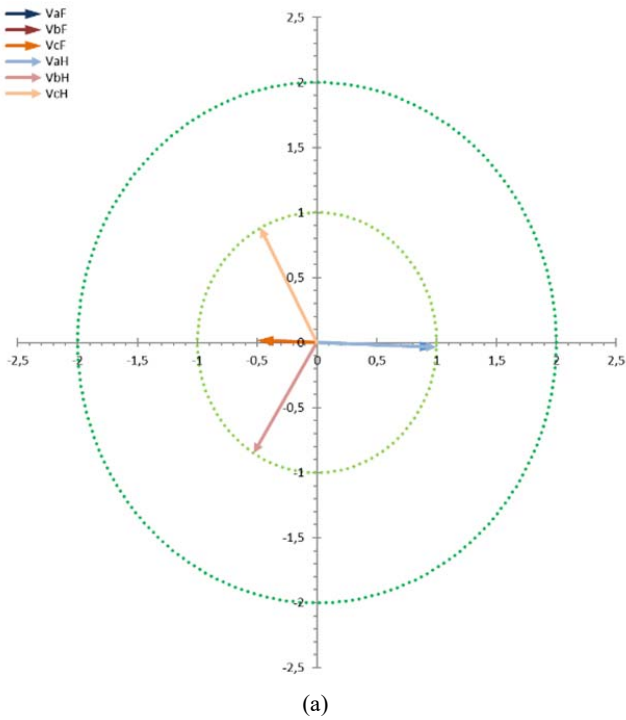

Fig. 12 Cases (a) 11-5-1-2ph-1, (b) 11-5-1-2ph-3, (c) 11-5-1-2ph-5

REFERENCES

- [1] M. Bollen, Understanding Power Quality Problems: Voltage Sags and Interruptions, Anderson P.M., pp. 190-198, 2000.
- [2] M. Moschakis, S. Loutridis, V. Dafopoulos, A. Anastasiadis, T. Tomtsi, E. Karapidakis, and A. Tsikalakis, "Prediction of Voltage Sags Applying the Method of Critical Distances to Meshed Power Networks", in Proc. of IEEE PMAPS (Probabilistic Methods Applied to Power Systems) Conference, pp. 570-575, Istanbul, Turkey, June 10-14, 2012.
- [3] M. Aung, and J. Milanovic, "The Influence of Transformer Winding Connections on the Propagation of Voltage Sags", IEEE Trans. on

- Power Delivery, vol. 21, no. 1, pp. 262–269, January 2006.
- [4] M. McGranaghan, D. Mueller, and M. Samotyj, “Voltage Sags in Industrial Systems”, IEEE Trans. on Industry Applications, vol. 29, no. 2, pp. 397–403, March/April 1993.
- [5] J. Moshtagh, and H. P. Souraki “Characteristics Analysis of Voltage Sag and Voltage Swell in Multi-Grounded Four-Wire Power Distribution Systems”, World Academy of Science, Engineering and Technology, Issue 31, July 2009.
- [6] IEC 60076-1 Standard, Power Transformers – Part 1: General, 1999.
- [7] IEEE C57.12.00 Standard, General Requirements for Liquid Immersed Distribution, Power, and Regulating Transformers, 2000.
- [8] IEEE C57.12.70 Standard, Terminal Markings and Connections for Distribution and Power Transformers, 2000.
- [9] M. N. Moschakis, V. V. Dafopoulos, I. G. Andritsos, E. S. Karapidakis, and J. M. Prousalidis, "The Effect of Transformer's Vector Group on Retained Voltage Magnitude and Sag Frequency at Industrial Sites Due to Faults", International Journal of Electrical Science and Engineering Vol:7 No:7, 2013.
- [10] R. C. Dugan et al., Electrical Power Systems Quality, 2nd ed. ser. Professional Engineering, New York: McGraw-Hill, 2002.
- [11] IEEE Recommended Practice for Design of Reliable Industrial and Commercial Power Systems, 1997.
- [12] IEEE Recommended Practice for Evaluating Electric Power System Compatibility with Electronic Process Equipment, 1998.
- [13] A Draft Standard Glossary of Power Quality Terminology, Jul. 15, 1999. P1433/D5A, Prepared by The Working Group on Power Quality Definitions of SCC22-Power Quality.
- [14] M. Bollen and L. Zhang, “Analysis of voltage tolerance of ac adjustable-speed drives for three-phase balanced and unbalanced sags,” IEEE Trans. Ind. Appl., vol. 36, no. 3, pp. 904–910, May/Jun. 2000.
- [15] Official Government Gazette of the Hellenic Republic 78/B’, Article No: 13 – Electrical Power Network Short-circuit Power, pp579, January 20, 2017.
- [16] Official Government Gazette of the Hellenic Republic 78/B’, Article No: 15 – Electrical Power Network Grounding, pp580, January 20, 2017.
- [17] Manitoba HVDC Research Center, PSCAD-Power Systems Simulation Software, Version 4.2, Canada, 2004.