

Development of One-Axis Didactic Solar Tracker for Photovoltaic Panels

L. J. de Bessa Neto, M. R. B. Guerra Vale, F. K. O. M. Varella Guerra

Abstract—In recent years, solar energy has established itself as one of the main sources of renewable energy, gaining a large space in electricity generation around the world. However, due to the low performance of photovoltaic panels, technologies need to be sought to maximize the production of electricity. In this regard, the present study aims to develop a prototype of solar tracker for didactics applications, controlled with the Arduino® platform, that enables the movement of photovoltaic plates in relation to the sun positions throughout the day through an electromechanical system, optimizing, thus, the efficiency of solar photovoltaic generation and improvements for the photovoltaic effect. The solar tracking technology developed in this work was presented of the shape oral and practical in two middle schools in the municipality of Mossoró/RN, being one of the public network and other of the private network, always keeping the average age of the students, in the case, around 16 years, contemplating an average of 60 students in each of the visits. Thus, it is concluded that the present study contributed substantially to the dissemination of knowledge concerning the photovoltaic solar generation, as well as the study of solar trackers, thus arousing the interest and curiosity of the students regarding the thematic approached.

Keywords—Alternative energy, solar tracker, energy efficiency.

I. INTRODUCTION

THE generation of energy by the sun is inexhaustible on the Earth's time scale, both as a source of heat and light, and has become one of the most promising energy alternatives for facing the challenges of the new millennium. When it comes to energy, it should be remembered that the sun is responsible for the origin of practically all other energy sources, in other words, energy sources are ultimately derived from the energy of the sun [1]. However, with the growing world population and, consequently, the world's electricity consumption, the use of alternative energy sources is becoming increasingly important, as it will become increasingly difficult to obtain the resources needed to generate energy using conventional, depleted energy sources, such as fossil fuels, over time. In this context, technologies must take into account, in addition to energy efficiency, the environmental appeal that the world is making.

Among the ways of making use of solar energy, the photovoltaic generation of electricity presents itself as one of the most promising. This type of electricity generation has been drawing attention to the availability and growth of installed capacity, clean electricity generation, not emitting greenhouse gases or acid gases, and no lakes need to be formed for reservoirs; deforestation is only carried out in some

Luiz José De Bessa Neto is with the Federal Rural University of the Semi-Arid Region, Brazil (e-mail: luizjbessa@outlook.com).

cases, because, in most situations, generation parks are built in desert or semi-arid locations [2].

Among the technologies used in generation distributed from renewable sources, the use of solar generation by photovoltaic cells has been gaining a lot of space in electrical systems around the world. In Brazil, it is noted that following the normative resolution 482/2012 published by ANEEL, regulating the connection of micro and mini-grid to the electricity grid, added to the relatively high levels of solar radiation in Brazil indicate a favorable scenario for the significant increase in the implantation of distributed photovoltaic systems connected to the electricity network [3].

The efficiency of solar photovoltaic systems is still considered low, and it is necessary to look for technologies for optimizing solar panels, thus making the most efficient and consequently, competitive solar source in relation to other renewable energy sources. In this sense, the energy efficiency of a photovoltaic solar panel can be substantially improved using solar-tracking systems. Studies with the use of these devices have been being carried out around the world, and show significant increases in the production of electricity [4].

In view of the above, the current work has the objective of developing a prototype of a solar tracker controlled with the Arduino® platform, which will provide for the movement of photovoltaic plates in relation to the positions of the sun throughout the day through an electromechanical system, thus optimizing the efficiency of the photovoltaic solar generation and providing improvements for the photovoltaic effect.

II. PHOTOVOLTAIC SYSTEMS WITH SOLAR TRACKING

A solar tracker is a device that tracks the trajectory of the sun from east to west during the day. In this sense, solar tags seek to keep the photovoltaic panels, or panel arrangements, energy concentrators, or solar collectors oriented directly to the rays of light coming from the sun, regulating the angle between the incidence radius and the solar panel at 90° [5]. Thus, the use of solar trackers significantly increases the amount of solar energy incident on the panels, therefore increasing the efficiency of the panel as well as the electrical energy generated at the output. This type of device can increase electricity production by 30-40%, varying depending on the installation location of the photovoltaic system, and the type of solar tracker used for position control [5], [6].

The solar trackers can be classified in relation to the number of rotary axes and the sun position tracking strategy. In this bias, on single-axis solar trackers, panels can rotate around a vertical axis, an inclined (or polar) axis, or a horizontal axis. The inclined axis may have a north-south orientation, i.e.

parallel to the earth's axis of rotation, depending on the latitude of the place. The horizontal axis can be driven north-south (tracking the sun from east to west) or east-west (with north-south tracking) [7]. Fig. 1 represents the axis types of a solar tracker of a degree of freedom.

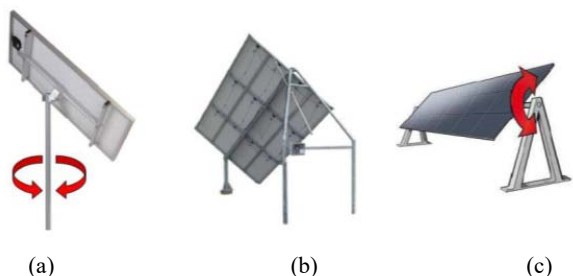

Fig. 1 Axis type: (a) a vertical axis; (b) a polar axis; (c) a horizontal axis [7]

This type of tracker has lower cost and lower accuracy. However, the energy efficiency of this type of axis configuration is higher in equatorial regions, where the incidence of solar rays does not vary significantly with the earth's movement relative to the sun [8]. By contrast, a two-degree solar tracker combines the horizontal axis with the vertical axis. In view of this, this solar tracking system can capture more light, giving greater efficiency to the photovoltaic panel. However, this arrangement of axes is more complex in relation to mechanics and position control, as well as being more expensive, although more accurate. Because there is movement in all directions, for the implementation of this type of tracker, a larger area of land is required. Fig. 2 denotes a two-axis solar tracker.

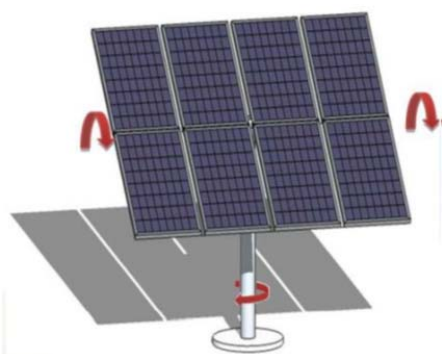

Fig. 2 Two-axis solar tracker, adapted from [8]

Throughout the above, a pertinent study related to the efficiency of photovoltaic solar generation systems developed at the Federal Rural University of Semiarid (UFERSA) is presented by [8], demonstrating a comparative analysis of the performance between a static and tracking solar panel in an axis in the city of Mossoró, in the state of Rio Grande do Norte, Brazil, located in the northeastern semiarid. Because the city is positioned close to the equator, the incident solar radiation does not fluctuate greatly and the sun's rising position remains virtually constant throughout the year, justifying the use of a solar tracker of only one degree of

freedom. Thus, the average gain in mobile module power generation was 11% over the static module, disregarding the energy consumed by the tracking system itself. Thus, the low increase in the efficiency of the mobile module with the solar tracking system is due to the proximity of the region to the equator line, since there are no drastic variations in sun position throughout the year.

III. MATERIAL AND METHODS

In order to develop a compact solar tracking system capable of optimizing the efficiency of photovoltaic panels in the conversion of solar light energy into electrical energy, as well as disseminate knowledge concerning solar photovoltaic generation in the middle schools of the municipality of Mossoró/RN, a prototype of a small-scale solar tracker made for didactic applications was made. In this sense, the following components were used for its development: a monocrystalline silicon photovoltaic cell, having a power of 1.98Wp; two Light Dependent Resistors (LDR) light sensors, which are used for detecting the positioning of the sun throughout the day; a servomotor with a 180° rotation range, which acts in the vertical direction of the photovoltaic cell; and an Arduino® Mega platform for photovoltaic system automation.

The mechanism for solar tracking has been designed with a lightweight metal frame, thus providing smooth and precise movements. In this case, the servomotor is fitted to the end of the first frame which is fixed to the quadrangular base. The rotating part of the servomotor is connected to a second frame, whereby the photovoltaic cell and the shading frame comprising the light sensors are also attached. Thus, as the servomotor is powered by the Arduino® Mega, the second mechanism tracks this movement and rotates the photovoltaic cell toward the light position throughout the day, providing greater efficiency in electricity generation. To demonstrate the use of the energy generated by the photovoltaic system, we used a 12V battery that stores the energy produced and feeds a cooler. Fig. 3 denotes the prototype of the single axis solar tracker developed in this work.



Fig. 3 Solar tracker for photovoltaic panels with didactic applications

A. Description of the Solar Tracker Electronic Components

In order to demonstrate the electricity generation of the solar tracking system, a monocrystalline Si (silicon)

photovoltaic cell was used, which is the fundamental unit of the process of converting light energy into electrical energy. In this bias, its working principle is based on the photovoltaic effect which is the appearance of a potential difference at the ends of a semiconductor material structure, caused by light absorption. In this way, a series of parallel-encapsulated photovoltaic cells form the so-called photovoltaic modules. Fig. 4 illustrates the photovoltaic cell used in the solar tracker prototype developed in this work.



Fig. 4 Monocrystalline Si photovoltaic cell, adapted from [9]

The LDR sensor is an electronic semiconductor device that has two terminals and the interesting feature of having a certain resistance according to the amount of light incident on it almost linearly, besides being a non-polarized element, causing the current to circulate in both directions. Knowing that conductive elements in electrostatic theory denote an energetic difference between the valence band and the practically zero conduction band (without offering obstacles to current flow) and that insulating materials behave in reverse (very large energetic difference); Semiconductors, in turn, have the energy difference between the value of conductors and insulators and need some external force, such as brightness and temperature to conduct the electric current [10]. Fig. 5 shows the LDR light sensor as well as its symbology in electronic circuits.

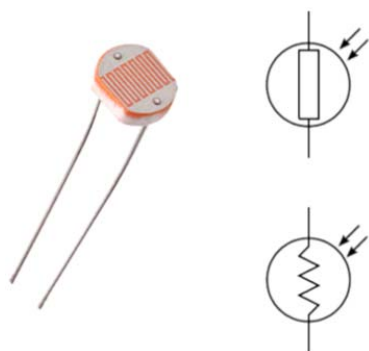

Fig. 5 LDR light sensor and its symbology in electronic circuits. Adapted from [10]

To direct the photovoltaic cell in relation to the solar position throughout the day, a servomotor with a 180° rotation range was used coupled to one end of the solar tracker structure. This electromechanical device has an axis that

moves proportionally to a digital signal. For this reason, unlike conventional motors, which comprise a freely rotating shaft without effective position control, servomotors have the ability to precisely control their rotation, thus ensuring an approximate position. This feature is made possible by virtue of an electronic control system and a potentiometer that is connected to its output shaft, whereby it is possible to monitor the servomotor shaft angle. Fig. 6 represents the constituent parts of a servomotor.

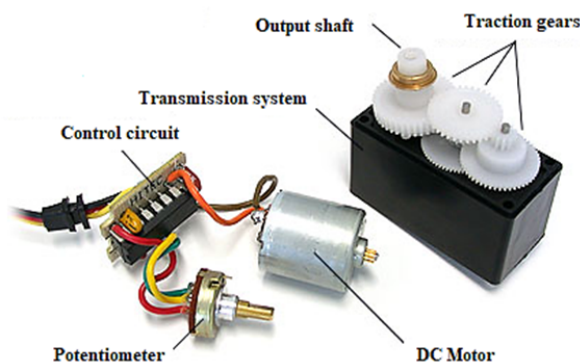

Fig. 6 Representation of the components that make up a servomotor, adapted from [11]

For the automation of the solar photovoltaic tracking system developed, the Arduino® Mega platform was used. Based on the 256 KB ATmega2560 microcontroller, the Arduino® Mega has 54 pins for digital inputs and outputs, so 15 of these can be used as PWM outputs. In addition, it has 16 analog inputs and 4 communication ports. However, the card can be powered via an AC-DC adapter, or via the USB port, allowing serial communication with a computer. It is worth noting that any other Arduino® platform could be used for the automation and control of the solar tracking system suggested in this study, such as Uno, Nano or Micro.

B. Solar Tracker Control Electronic Circuit Simulation

In the solar tracking system, the microcontroller receives the analog signals sent by the light sensors (LDR's) proportionally to the light intensity incident on them, which is differentiated by a shading structure. In this sense, the conventional command lines inserted in Arduino® programming seek to balance the received signals and convert them into digital values that are sent to the servomotor, whereby it will rotate the photovoltaic cell at specific angles according to sun position. Fig. 7 shows the electronic control circuit of the solar tracker.

The solar position sensing system is formed by an artifact consisting of two 5 mm LDR separated by an opaque bulkhead responsible for generating the shadow resulting from the movement of the sun. LDRs detect the variation in brightness as any sensor is shaded due to the natural movement of the sun. In this way, the microcontroller identifies this difference and triggers actuation commands to correct the position of the photovoltaic panel so that both sensors receive the same incidence of light. Fig. 8 represents

the arrangement of the sensors in the shading structure.

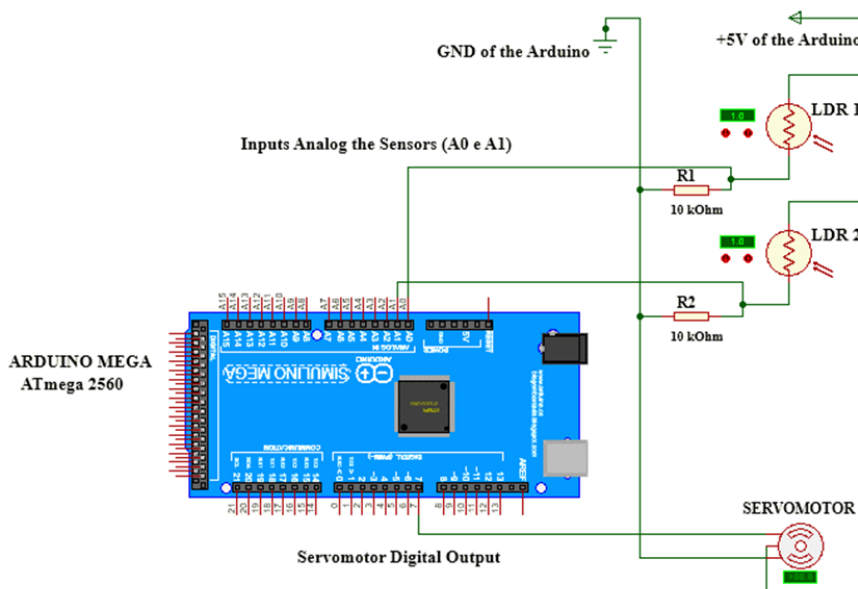

Fig. 7 Simulation with Arduino® Mega ATmega2560 Platform

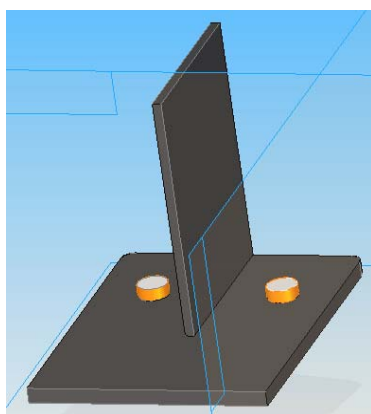

Fig. 8 Separate bulkhead LDR sensors

It is essential to point out that the solar tracking system suggested in this work can be used anywhere in the world because it is self-adjusting, and it is not essential to determine the time, climate factors, definition of geographic coordinates or orientation of positioning for equipment installation. Therefore, as soon as the operator installs the device, the system will automatically track the sun's positioning, adjusting the angles as the sun moves throughout the day.

C. Didactic Application

The solar tracking system developed in the present work was presented to middle class groups orally and practically in two schools in the municipality of Mossoró/RN. Before starting the presentation, a questionnaire was given to analyze if the students had any previous knowledge of the basic fundamentals of solar energy, as well as its possible applications. The questionnaire has four basic questions: (1) What is solar energy? (2) How can solar energy be used?

(alternatively: thermal power generation, electric power generation or I don't know how to answer), (3) Do you know solar photovoltaic power? Finally, (4) Do you know that solar energy can generate energy to power your home?

After applying the questionnaire, the presentation began by highlighting about solar energy, clarifying its terms and applications. Subsequently, the types of solar radiation (direct and diffuse) were defined, as well as their characteristics. Therefore, the principle of operation of solar panels based on the photovoltaic effect, that is, on the process of direct conversion of light into electricity, was shown. After this initial step, solar tracking technology was explained, exposing its advantages and improvements related to the energy efficiency of fixed photovoltaic panels. Then, the prototype of the solar tracker developed was presented, explaining the solar position sensing and the function of the photovoltaic system electronic components.

IV. RESULTS AND DISCUSSION

Due to the data obtained in the application of the previously mentioned questionnaires, it became possible to evaluate the students' previous knowledge concerning solar energy, as well as their acceptance in relation to the didactic solar tracking system developed in this study. In this context, as mentioned above, two high schools were visited, one from public schools and one from private schools, in the city of Mossoró/RN, always maintaining the average age of the students, in this case, around 16 years old. Thus, in each of the schools the solar tracker was presented in two classes, contemplating an average of 60 students in each of the visits.

A. School Visit 1

The first visit was made in two classes, one in the first

grade and one in the second grade of a high school in a public school. In the introduction, the questionnaire was delivered to the classes in order to analyze if the students had a previous knowledge concerning solar energy. After the students completed the questionnaire, the presentation began defining the main concepts of solar energy, as well as their possible applications, with a greater emphasis on solar photovoltaic generation. Therefore, the solar tracker in operation was demonstrated by analogizing the position of the sun with a flashlight. Thus, it became possible for students to visualize in a practical and didactic way the solar position tracking technology throughout the day.

By applying the questionnaire to the classes of the first school, it became possible to realize that 68% of the students did not know about solar energy. Regarding the use of this renewable source, 75% of students said they do not know how solar energy could be used. In contrast, 12% stated that the solar resource can be used for electricity generation, 5% for water heating and 8% for both applications, both for water heating and for electricity production. Regarding solar photovoltaic system technology, it was found that 92% of the students had never heard of this term, claiming they had no idea what it was about. Moreover, it was observed that 73% of the students were unaware that solar energy can be used to generate electricity for their own home. In this sense, it is evident, therefore, that most of the students interviewed in the first school had no knowledge concerning the theme addressed in the present work.

B. School Visit 2

The second visit was made again in two classes, one in the first grade and another in the second grade in a private school. In this perspective, analogously to the first meeting, the questionnaire was delivered to the classes in order to ascertain the students' previous knowledge related to the theme addressed. Therefore, the presentation began by exemplifying the main concepts of solar energy and, later, demonstrated the solar tracker in operation.

By applying the questionnaire in the classes of the second school, it became possible to verify that 53% of the students did not know about solar energy. Regarding the use of this renewable source, 55% of students said they do not know how solar energy could be used. On the other hand, 19% stated that solar energy can be used for electricity generation, 9% for water heating and 17% for both modes, both for water heating and for electricity production. Referring to photovoltaic solar system technology, it was observed that 69% of students had never heard of this expression, noting that they had no idea what it was. In addition, it was found that 56% of students were unaware that solar energy can be used to generate electricity for their own home. In this context, it is evident, therefore, that most of the students interviewed in the second school also did not have knowledge related to the dissertated theme.

V. CONCLUSION

By making a solar tracker for photovoltaic panels, as well

as the data obtained in the application of the questionnaire in schools, it can be concluded that the objectives of this work were successfully achieved, since it contributes significantly to the dissemination of knowledge concerning the photovoltaic solar generation and the study of solar trackers in the school environment; thus, arousing the students' interest and curiosity regarding the thematic approached.

Another consideration to be made is that all students understood that the solar tracker (movable solar panel) would be more efficient in generating electricity compared to a fixed solar panel, since it rotates the cell photovoltaics towards the sun's position throughout the day, providing greater energy efficiency for photovoltaic panels. In view of the above, the developed solar tracker prototype proved to be satisfactory, becoming an excellent teaching tool, capable of providing interdisciplinarity in the educational field.

In terms of economic viability, the solar tracking system proposed in this study was also interesting, considering that it can be implemented in any scope because it is self-regulating, and no parameter for determining time, climate factors, definition or geographic coordinates or positioning orientation for device installation.

REFERENCES

- [1] Bajpai, P., Kumar, S. "Design, Development and Performance Test of an Automatic Two-Axis Solar Tracker System", *Institute of Electrical and Electronics Engineers - IEEE India Conference*, Hyderabad, p. 1-6. 2011.
- [2] Renosto, A. S., et al., "Solar Follower Photovoltaic System Prototype for Didactic Application", *VII Brazilian Congress of Solar Energy - CBENS*, Gramado, Apr. 2018. p. 2-10.
- [3] Shufat, S. A. A., Kurt, E., Hancerlioğullari, A., "Modeling and Design of Azimuth-Altitude Dual Axis Solar Tracker for Maximum Solar Energy Generation", *Renewable Energy*, p.7-13. 2019.
- [4] Kulkarni, A., et al., "An Intelligent Solar Tracker for Photovoltaic Panels", *Institute of Electrical and Electronics Engineers - IEEE India Conference*, Bangalore, p.3-7. 2014.
- [5] Cortez, R. J. M., "Solar Tracking System in Photovoltaic Energy Production", 2012. 94p. Faculty of Engineering of Porto - FEUP, Portugal.
- [6] Pinto, A., et al., "Description of Solar Followers and Its Application in Grid Connected Photovoltaic Power Plants", *III Brazilian Congress of Solar Energy - CBENS*, Pará, Brazil, 2010.
- [7] Silva, M. C. C., "Comparative Study of a Fixed vs Mobile Photovoltaic Solar Panel", 2012. 125p. School of Engineering, University of Minho, Braga.
- [8] Vieira, R. G., "Performance Analysis Between a Static and Tracking Solar Panel in the Municipality of Mossoró-RN", 2014. 85p. *Postgraduate Program in Communication Systems and Automation*, Federal Rural University of Semi-Arid-UFERSA, Mossoró, Rio Grande do Norte, Brazil.
- [9] Pinho, J. T., Galdino, M. A., "Engineering Manual for Photovoltaic Systems", *Solar Energy Working Group - GTES*, Rio de Janeiro, 2014.
- [10] Mendes Junior, J. J. A., Stevan Júnior, S. L., "LDR and Ambient Light Sensors: Operation and Applications", 2013. 8p. *Electronics and Automation Week*, Federal Technological University of Paraná - UTFPR, Brazil.
- [11] *Robocore Tecnologia Ltda*, "Your technology proof", Available at: <<https://www.robocore.net/>>. Accessed on: 20 of July 2019.

Luiz José de Bessa Neto It has Graduated in Science and Technology from the Rural Federal University of Semi-Arid (2019) and technical in Oil and Gas from IFCE - Federal Institute of Education, Science and Technology of Ceará (2016). Currently is graduating student Electrical Engineering Electrical at the Federal Rural University of Semi-Arid. Has skills in the area of Electrical

Engineering, working mainly with photovoltaic solar energy, electronics and industrial electrical controls.

Marcelo Roberto B. Guerra Vale Graduated in Computer Engineering from Potiguar University (2005), Mastering in Electrical Engineering from Federal University of Rio Grande do Norte (2007) and PhD in Electrical Engineering and Computing from Federal University of Rio Grande do Norte (2014). He is currently Associate Professor II at the Rural Federal University of Semi-Arid and permanent member of the Postgraduate Program in Communication and Automation Systems (PPGSCA/UFERSA). Has experience in Electrical Engineering, focusing on automation and process control.

Fabiana Karla de O. M. Varella Guerra Graduated in Civil Engineering from Potiguar University (2001), Mastering in Energy Systems Planning - UNICAMP (2004) and PhD in Energy Systems Planning - UNICAMP (2009). She is currently Associate Professor I of the Electrical Engineering Course at UFERSA and a permanent member of the Postgraduate Program in Communication and Automation Systems (PPGSCA/UFERSA). Has experience in Mechanical Engineering, focusing on Energy Systems Planning, working mainly with alternative renewable energies, thermal solar energy, photovoltaic solar energy and energy efficiency.