

Automated Monitoring System to Support Investigation of Contributing Factors of Work-Related Disorders and Accidents

Erika R. Chambriard, Sandro C. Izidoro, Davidson P. Mendes, Douglas E. V. Pires

Abstract—Work-related illnesses and disorders have been a constant aspect of work. Although their nature has changed over time, from musculoskeletal disorders to illnesses related to psychosocial aspects of work, its impact on the life of workers remains significant. Despite significant efforts worldwide to protect workers, the disparity between changes in work legislation and actual benefit for workers' health has been creating a significant economic burden for social security and health systems around the world. In this context, this study aims to propose, test and validate a modular prototype that allows for work environmental aspects to be assessed, monitored and better controlled. The main focus is also to provide a historical record of working conditions and the means for workers to obtain comprehensible and useful information regarding their work environment and legal limits of occupational exposure to different types of environmental variables, as means to improve prevention of work-related accidents and disorders. We show the developed prototype provides useful and accurate information regarding the work environmental conditions, validating them with standard occupational hygiene equipment. We believe the proposed prototype is a cost-effective and adequate approach to work environment monitoring that could help elucidate the links between work and occupational illnesses, and that different industry sectors, as well as developing countries, could benefit from its capabilities.

Keywords—Arduino prototyping, occupational health and hygiene, work environment, work-related disorders prevention.

I. INTRODUCTION

WORK-RELATED accidents and illnesses threaten workers, their health and quality of life. Additionally, these can also have profound economic effects to different industry segments. According to the Health and Safety Work Commission in Canada [1], the European Agency for Safety and Health at Work [2] and others agencies from different countries including the United States of America [3], workplace accidents and work-related illnesses are contributing to heavily burdened social security systems worldwide. In developing countries this issue is even more critical. Is it estimated that in Brazil there is one work accident every 57.5 seconds, accounting for a yearly burden of USD 63 billion or 3.7% of the country's GDP [4], [5].

E. R. Chambriard is with the School of Health & Social Development, Deakin University, Burwood, VIC 3125, Australia (corresponding author, e-mail: ekachambriard@hotmail.com).

S. C. Izidoro and D. P. Mendes are with the Universidade Federal de Itajubá, Minas Gerais, 37500-903, Brazil.

D. E. V. Pires is with the School of Computing and Information Systems, University of Melbourne, Melbourne, VIC3052, Australia (corresponding author, e-mail: douglas.pires@unimelb.edu.au).

Work-related illnesses can be categorized into three major groups: group 1 are those illnesses that are already known and proven as directly related to work and have work as a "necessary cause"; group 2 includes those for which the activity acts as a "contributing" risk factor, therefore requiring its correlation to be assessed and proven; and group 3, those situations where the worker already has a health condition or a propensity to develop a condition or a disease and the work acts as a "trigger" or "aggravator" for the disorder/illness [6].

Clinical examination, as the standard practice worldwide, has been shown to be insufficient to infer causality between work activity and the developed condition, since work-related diseases often have a latent period and, on many occasions, when they manifest, the worker is no longer developing the same activity [7]. In this context, novel tools and mechanisms capable of detailing and quantifying the aspects and probable causes of illnesses and accidents of workers and their work environment are invaluable and may help the elucidation or refutation of correlations between the work done and the disease developed. A pioneering initiative at the Brazilian Reference Center for Worker Occupational Health (in Portuguese, Centros de Referência Especializados em Saúde do Trabalhador - CEREST) was proposed to integrate the services from the Brazilian public health system devoted to assistance and surveillance, creating mechanisms to aid elucidating work-related accidents and injury causes, as well as strategically acting to prevent them [8]. Those mechanisms, despite presenting positive results significantly decreasing work-related accidents and improving work conditions in the region of the aforementioned study, also present an important limitation: they were triggered only when the workers are already ill or sick and, normally showing loss of limb shape or function. This means that most health systems are only capable of corrective rather than preventive measures. In this way, there is a considerable demand for a mechanism capable of compiling historical and present data related to working environment conditions to help elucidate the links between them and threats to workers' health, as well as preventing future damage. An automated data collection system capable of constantly monitoring workers and their working environment would generate valuable data to prevent injuries and accidents and pinpoint their potential causes.

Different technologies have become popular and routinely used, for continuously monitoring environmental or health indicators (e.g., e-health or m-health systems), and have been increasingly used for clinical assistance globally [9]. Different

types of devices that monitor health indicators and potential issues or emergency situations are now available on the market. The possibility of developing technologies with similar purposes to e-health, but focused on the worker and his work environment, could be an interesting and pertinent way to bridge the gap between work-related illnesses and their causes.

The popularization of prototyping platforms and wide availability of sensors for measuring environmental characteristics with high precision appears in this context as an efficient and affordable alternative for the evaluation and real-time monitoring of the work environment through a computerized system.

In this work, we present a flexible, cost-effective, automated workplace monitoring system, based on the well-established prototyping platform Arduino, capable of accurately collecting environmental indicators to create a historical database for assisting the elucidation of the causes of work-related accidents and diseases.

II. MATERIAL AND METHODS

A. Prototyping Platform and Sensor Modules

Occupational hygiene equipment is normally used to carry out the measurements of work environment characteristics in different scenarios, many of which are hostile, such as overly humid, dangerously hot, presenting high radiation levels, amongst others. The range of environmental characteristics in which the equipment should be tested makes the design of this type of technology significantly more complex, by requiring a number of experiments in real situations that are too long for problems and failures to be perceived and solved [10]. To circumvent this, the developed automated monitoring equipment was initially tested on simulated data, thus preserving the researches health and safety and allowing to test the equipment for long periods on a large assortment of diverse and potentially hazardous work environments. Once the virtual tests stage was finished, the physical prototype was built.

In this work, we used Arduino [11], a cost-effective well-established open-source prototyping platform. The platform used was selected among others available in the market considering its popularization and compatibility with electronic modules available, allowing full personalization both in software and hardware levels. The developed prototype based on an Arduino MEGA uses a series of modules that constantly read the information from the environment, process and store them, so they can be transferred to a computer where the data will be analyzed and displayed, for instance as time series. Fig. 1 displays the overall prototype sketch and its main components.

The detailed list of selected modules to monitor each environmental variable is described in Table I as well as the others components used.

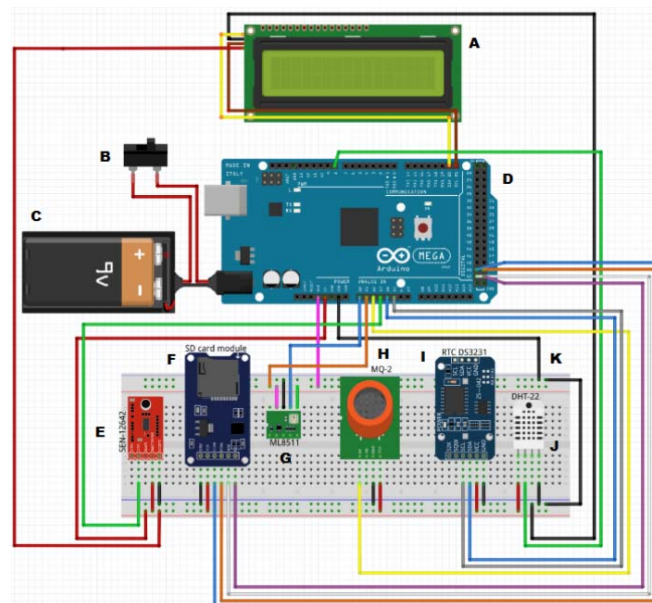

Fig. 1 Prototype sketch including its main components: (A) a LCD screen with 16x2 characters where the current measurements is displayed, (B) an On/Off switch, (C) the prototype power source, a 9V battery, (D) the prototyping board used in this study, an Arduino Mega, (E) the sound pressure level sensor, (F) a SD Card module for persistent memory, (G) an ultraviolet index sensor, (H) the gas sensor, (I) a real time clock for timestamping the measurements, (J) the temperature and humidity sensor and (K) a solderless protoboard used to connect the sensors and prototyping board

TABLE I
 DESCRIPTION OF COMPONENTS USED IN THE PROTOTYPE

Component	Module model	Description
A - LCD Screen (16x2 characters)	1602IIC	Voltage: 5V, 4 pins
B - Switch On/Off	R1966ABLKbLKFF	Max. current: 15A, 2 pins
C - 9V battery and adapter	9V battery & Arduino adapter	Input: 9V battery
D - Prototyping Board	MEGA 2560	54 digital pins, 16 analogical pins, 16 MHz
E - Sound Pressure Level sensor	SEM-12642	Range: 70 - 130 dB
F - Persistent Memory	SD Card Module	Micro SD Card, 6 pins
G - Ultraviolet (UV) Index sensor	ML8511	Range: 0 a 15 mW/cm ² Accuracy: ±0.1 mW/cm ² LPG and propane: 200 - 5000 ppm
H - Combustible Gases sensor	MQ-2	Butane: 300 - 5000 ppm Methane: 5000 - 20000 ppm H ₂ : 300 - 5000 ppm Alcohol: 100 - 2000 ppm Accuracy: ±2 minutes/year
I - RTC - Real Time Clock	DS3231	
J - Temperature and Humidity sensor	DHT11	Temperature range: 0 - 50 °C Accuracy: ±2 °C Humidity range: 20 - 80% Accuracy: ± 5%
K - Solderless Breadboard	MB-102	630 tie-point IC-circuit area with 2x100 tie-point distribution strips

The electronic components used during this work were: Sound detector SEN-12642, which was selected between other

available in the market given its working window to measure sound levels in decibels, and its onboard amplifier; Temperature and humidity sensor DHT11 module, selected taking into consideration its capacity of measuring temperature and humidity simultaneously and also its working window encompasses a wide range of real-world working environments;

Ultraviolet (UV) sensor ML8511, taking into consideration its high precision as well as low energy consumption, a fundamental requirement for the prototype development, which is intended to work having a 9V battery as power supply throughout an entire working day without needing an external power supply nearby; Gas sensor MQ-2, designed to read combustible gases and smoke concentrations in the air, was selected to represent the MQ family of sensors capable of working with a range of different gases; RTC - Real Time Clock DS3231 module, which is a highly accurate RTC, capable of working in a range of environmental condition, that holds its own battery and SD card module for storing the collected information in persistent memory.

B. Environmental Indicators

Relevant factors of the work environment were selected according to their importance to workers health and safety and availability of technologies used to measure those factors at an environmental level. The environmental factors selected included temperature, humidity, ultraviolet index, presence and amount of gases and sound pressure, which are continuously collected, analyzed and stored in the device.

Measurements were collected using two different types of devices, the proposed prototype and control equipment (equipment available in the occupational hygiene market used to measure each specific factor). The occupational hygiene equipment used during the tests and the environmental factors collected by them are briefly described in Table II. The environmental data was collected in the same conditions by both prototype and control equipment, the later was also used to validate the prototype.

TABLE II
 DETAILS OF CONTROL EQUIPMENT

Environmental Aspect	Control Equipment
Presence and Concentration of Gases	MultiRAE Lite Wireless Portable Multi-Gas Monitor - PMG6208 - RAE Systems
Dry-Bulb Temperature	HT-3017 - LT Lutron
Wet-Bulb Temperature	HT-3017 - LT Lutron
Globe Temperature	HSM 721 - DOBBIE INSTRUMENTS
Sound Pressure Level	QM-1591 - DIGITECH
UV Index	QM-1677 - DIGITECH

C. Parsing Sensor Measurements and Calculating Environmental Variables

Environmental aspects were selected based on their relevance according to Brazilian work legislation, the impact in the workers life and sensor availability. The environmental aspects selected are described as follows.

- *Dry-Bulb Temperature (Td)*. An environmental variable obtained from a dry thermometer, measuring the effective environmental temperature. This variable is also

combined with the Wet-bulb Temperature and the Ultraviolet Intensity to obtain the Bulb Depression and Globe Temperature, respectively.

- *Wet-Bulb Temperature (Tw)*. Obtained via a wet-bulb thermometer, which usually is composed of a mercury thermometer with a tissue surrounding its bulb, retaining water that is gradually released as it evaporates. The web-bulb temperature (T_w), can be used to calculate wet-bulb depression (D), also using the dry-bulb temperature (T_d) (all given in °C), as shown in (1).

$$T_d - T_w = D \quad (1)$$

- *Globe Temperature or Black Globe Temperature (Tg)*. Aims to measure the radiating heat of an environment using a globe thermometer. Even though no miniaturized electronic module is currently available to measure globe temperature, globe temperature (T_g) can be approximated using dry-bulb temperature (T_d), using (2) for internal/indoor environments and (3) for external/outdoor environments [12]:

$$T_g = 0,4560 + 1,0335 T_d \quad (2)$$

$$T_g = -0,9387 + 0,8562 T_d + 0,0162 T_d^2 \quad (3)$$

- *Air Quality and Presence of Gases in the Work Atmosphere*. The health assessment of a work environment also depends directly on the variety and quantity of gases present in the work environment and its tolerable dose and limit established by law, specific for each gas component. The MQ-2 gas sensor was used to quantify CO presence in the environment in ppm.
- *Sound Pressure Level*. A measurement of the power of a sound wave determined by its amplitude. Noise at the work environment, according to the Brazilian Legislation, can be classified into two groups: impact noises (short duration intervals) and constant/intermittent noises (with longer duration intervals). Based on sensor readings, for any given period, exposure to impact or constant noises can be quantified. Different environments might expose workers to (constant or intermittent) damaging noise levels, which justifies its monitoring. We have used the microphone module SEN-12642, to convert sound in electric current, from which a sound pressure level can be estimated using (4):

$$SPL = SPL_{corr} + 20 * \log_{10} (I/I_{corr}) \quad (4)$$

where SPL is the sound pressure level (in dB), SPL_{corr} is a previously measured sound pressure level for which a current value (I_{corr}) is also known during calibration and I is the current value measured by the sensor.

- *Ultraviolet Intensity*. Refers to low-intensity energy waves incapable of promoting ionization (i.e., removing electrons from neutral atoms, transforming them into ions), measured using the GY-8511 sensor module. For categorizing the radiation intensity, it was used the UV

Index in Table III [15].

TABLE III
 UV RADIATION EXPOSURE CATEGORIES

UV Index Range	Exposure Category
0 - 2	Low
3 - 5	Moderate
6 - 7	High
8 - 10	Very High
>11	Extreme

- **Wet-Bulb Globe Temperature (WBGT).** Is used to measure heat exposure, dependent on solar exposure level (i.e., whether the work activity is being carried out indoors or outdoors under solar load). To detect solar load, the GY-8511 sensor module is used. Under solar load, WBGT can be calculated using (5), using wet-bulb temperature (T_w), dry-bulb temperature (T_d) and globe temperature (T_g).

$$WBGT = 0,7 T_w + 0,1 T_d + 0,2 T_g \quad (5)$$

WBGT for indoors activity is calculated using (6), using wet-bulb temperature (T_w) and globe temperature (T_g):

$$WBGT = 0,7 T_w + 0,3 T_g \quad (6)$$

D. Prototype Validation

Once the prototype was assembled, it was submitted to a series of calibration and validation tests. These took place at the Universidade Federal de Itajubá and were performed according to the following processes for each environmental variable:

- I. The prototype and calibrator were set up for each series of tests near each other in a way that both would be exposed to the same conditions;
- II. A warm-up period was allowed according to each equipment's instruction before each series of tests;
- III. Measurements started at the same time and for the same duration for both calibrator and prototype;
- IV. The conditions the devices were exposed to were gradually modified during the series of tests;
- V. After each series of tests, the measurements from each device were downloaded to a computer and analyzed.

Environmental variables were monitored using a series of occupational hygiene equipment. Each environmental variable measured had a different exposure period based on each equipment's instruction and warm-up period required, therefore, different exposure periods were used accordingly.

E. Data Analysis

Scatter plots were generated using R programming language, via the ggplot package. The linear correlation between measures obtained by the prototype modules and the calibrators was assessed via the correlation of determination (R^2) to evaluate the prototype functions and its accuracy.

The data collected by the prototype was stored in external memory (SD card) with measurements and timestamp in

comma-separated format to allow for easy-to-use integration with different analyses tools.

III. RESULTS

The prototype underwent a series of tests for each of the environmental aspects described in this paper. The following section presents the results of these measurements and the comparisons between control equipment and prototype data.

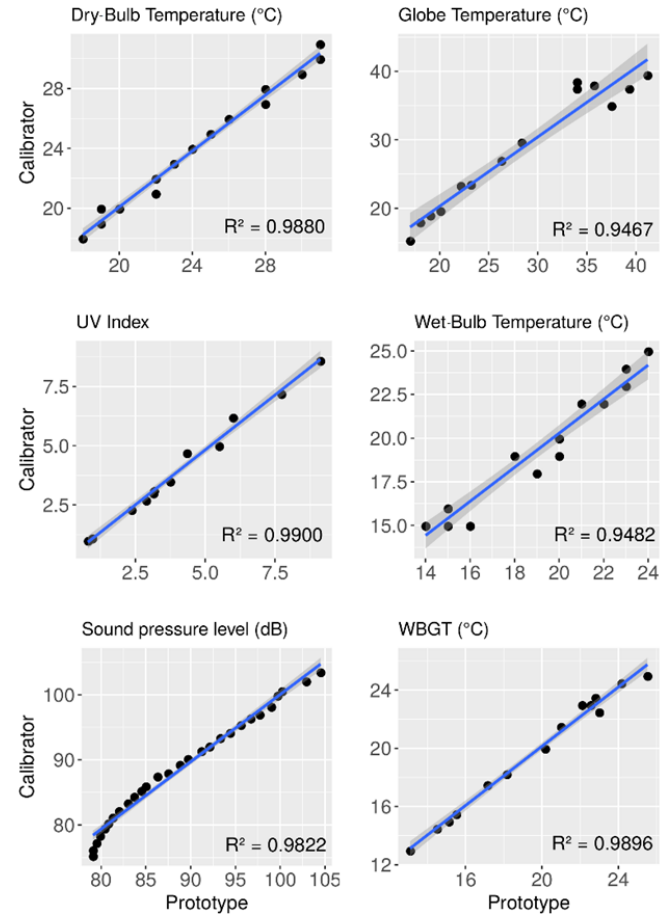

Fig. 2 Correlation plots between prototype and calibrator for environmental variables directly and indirectly measured with dedicated electronic modules: The correlation of determination (R^2) between measurements is shown in the bottom right corner and ranged from 0.95 to 0.99. Generated using ggplot.

As well illustrated in Fig. 2, the results of the prototype tests are compatible with the results obtained by the control equipment, demonstrating correctness and reliability of the prototype. Correlations of determination for the various environmental variables ranged from 0.95 to 0.99. When comparing the results of the various modules of the prototype with the control equipment, they presented different levels of accuracy, depending on whether the variables were direct measurements or not.

For the prototyping of the equipment developed in this work, specific sensor modules were used to verify the following characteristics: dry-bulb temperature, ultraviolet intensity and sound pressure level. These are considered

primary or directly measured data. The environmental aspects that were evaluated directly by the sensors had greater accuracy (on average $R2 = 0.9867$) than the ones that needed mathematical approximation owing to its inherent limitation (on average $R2 = 0.9615$).

The wet-bulb temperature, globe temperature and WBGT values obtained by the equipment are secondary data, as they were derived from the primary measurements and treated mathematically by transformation and/or estimate formulas available in the literature. Due to the inherent error in these mathematical approximations, the characteristics that required this type of treatment had slightly lower correlations, however the values found are within the expected error ranges considering the accuracy of each equipment and module.

Despite this observation, we believe the secondary measurements provide useful information to characterize the work environment, especially considering the lack of miniaturized sensor for their direct calculation. Moreover, these might not be limiting depending only on the specifications of each environment and aspects to be monitored.

It is noteworthy that the developed device is a cost-effective and highly modular equipment that can be adapted to various work sectors and environments, with minor changes in its sensor modules or programming libraries. For example, for regions whose temperature may vary below 0°C and/or above 50°C or for which relative humidity can reach below 20% and/or above 80%, a simple module replacement (module DHT-11 by the DHT-22) is enough to adapt the device to a completely new environment without the need of further alterations. This new module, although slightly more expensive, is capable of measuring temperature more widely and more accurately, it does not significantly change equipment price, maintaining its low cost and high accuracy. In addition, this modification does not imply replacing/altering the code implemented, which keeps the cost of the equipment and its maintenance low.

In a less likely scenario, in case of a change in the legal limits for each measured variable, it is also possible to adjust most of the modules without replacing them and/or drastically alter the code, requiring only the replacement, removal or addition of resistors, adjustments in sensors and/or simple code modification.

Another fundamental aspect focused during the development of this device, also regarding accessibility and simplicity, is the presentation of the data collected in relation to the work and occupational health legislation.

Using Excel Macros, the comma-separated document generated by the prototype allows the user to generate graphics (e.g., sound intensity vs. time) that enables any worker to analyze and understand the environmental conditions they are working in, regardless of their education level, and generate a history of the occupational hygiene of the work environment, as exemplified in Fig. 3.

The availability of comprehensible and useful information on work environments might help elucidate the connection between occupational disorders and accidents to the work

performed and to prevent new occupational disorders and accidents in the future.

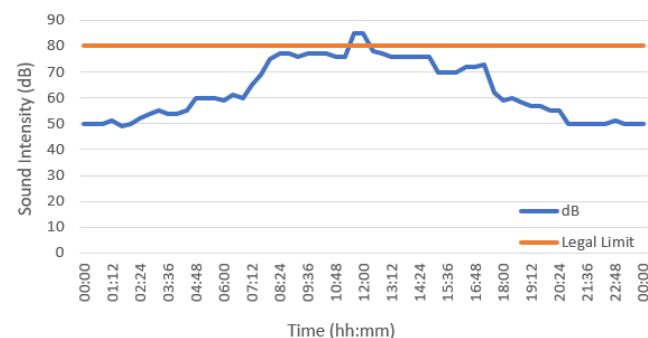

Fig. 3 Example of environmental aspect analyzed using the prototype and presented as a comprehensible graphic of sound intensity vs. time

The constant monitoring of the environmental aspects is the first step towards assisting in the prevention of different disorders and accidents. These include deafness, partial deafness, skin cancer, heat exhaustion, hyperthermia, intoxication and others, in a short period of time, and loss of thermal sensibility, prevention of accidents caused by the above-mentioned disorders and worse quality of life in the long term. In turn, this device will allow efforts to be focused on prevention rather than cure, reducing, as a consequence, the financial burden related to work injuries and improving workers life quality [13].

IV. CONCLUSION

In this work, we proposed a modular and low-cost work environment monitoring and characterization equipment that enables the establishment of a historical database of workplace conditions, in an easy-to-interpret format.

Prototyping was initiated at a virtual level so that the current, voltage and resistance values of the system's integral parts could be evaluated for the possibility of burning of the electronic components or short circuit. After the development period of the virtual device and a physical prototype, functional tests to enable the calibration of its components were performed in such a way that the operation of the device was verified and could be subsequently validated. As a last step, the physical prototype was tested with control equipment, environmental data was collected by both prototype and control equipment simultaneously and its correctness was demonstrated.

We believe we have started an important effort towards the development of new technologies that can be used in different ways to assist monitoring workplace environments, particularly relevant for developing countries. These efforts may, in the future, help elucidate links between workplace environment and developed illnesses.

Despite the fact that the work conditions have been improving over the last years and the work-related illnesses have been changing from musculoskeletal disorders to illnesses related to psychosocial aspects of work, there is still need to invest efforts in the comprehension of problems

related to the Occupational Health Model, from 1950 [14], especially in developing countries.

With these challenges in mind, the present study emphasizes that although measures to improve working conditions are being taken in different countries, automated approaches have not yet been fully explored. We expect this prototype could assist in elucidating the causes and contributing factors of future work accidents and, with that, the environmental working conditions can be reviewed and, if necessary, improved, aiming at the workers welfare.

ACKNOWLEDGMENT

The authors would like to thank A/Prof. Susanne Tepe from RMIT University, Melbourne and Brian Eva from Identifibre for the support provided during the testing stage, and Prof. Geraldo F. S. Moraes, for his support and feedback during the conclusion of the research.

REFERENCES

- [1] M. Lebeau and P. Duguay, "The Costs of Occupational Injuries: a Review of the Literature", *Institut de recherche Robert-Sauvé en santé et en sécurité du travail*, July 2013.
- [2] J. C. M. Mossink, M. Greef, "Inventory of socioeconomic costs of work accidents", Office for Official Publications of the European Communities, Jan. 2002.
- [3] Annual Statistical Supplement, *Social Security Administration*, United States of America., 2017.
- [4] Annual Statistical of Work Accident, *Brazilian Ministry of Finance*, Brazil, 2017
- [5] J. Takala, P. Hämäläinen, K. L. Saarela, L. Y. Yun, K. Manickam, T. W. Jin, P. Heng, *et al* "Global Estimates of the Burden of Injury and Illness at Work in 2012." *J. Occup. Environ. Hyg.*, vol. 11, no. 5, pp. 326-337, May 2014.
- [6] R. S. F. Schilling, "More Effective Prevention in Occupational Health Practice?" *J. Soc. Occup. Med.*, vol. 34, no. 3, pp. 71-79, 1984.
- [7] P. Hämäläinen, K. L. Saarela and J. Takala, "Global trend according to estimated number of occupational accidents and fatal work-related diseases at region and country level," *J. Saf. Res.*, vol. 40, no. 2, pp. 125-139, 2009.
- [8] R. Cordeiro, R. A. G. Vilela, M. A. T. Medeiros, C. G. O. Gonçalves, C. A. Bragantini, C. Stephan, *et al*, "A System for Occupational Injury Surveillance in Piracicaba, Southeastern Brazil," *New. Solut.*, vol. 17, no. 4, pp. 363-375, 2008.
- [9] J. D. Piette, K. C. Lun, M. A. J. Lincoln, F. S. F. Hamish, P. N. Mechael, J. Powell, *et al* "Impacts of E-health on the Outcome of Care in Low- and Middle-Income Countries: Where Do We Go from Here?" *Bull. World. Health. Organ.*, vol. 90, no. 5, pp. 365-372, 2012.
- [10] B. A. Mello, L. L. Caimi, "Simulação na validação de sistemas computacionais para a agricultura de precisão," *Revista Brasileira de Engenharia Agrícola e Ambiental*, vol. 12, no. 6, pp. 666-675, 2008.
- [11] M. Banzi, M. Shiloh, "Getting started with Arduino: the open source electronics prototyping platform," 3rd ed., Ed. Maker Media Inc, 2014.
- [12] P. G. Abreu, V. M N Abreu, L. Franciscon, A. Coldebella, A. G. Amaral, "Estimativa da Temperatura de Globo Negro a Partir da Temperatura de Bulbo Seco," *Revista Engenharia na Agricultura – REVENG*, vol. 19, no. 6, pp. 557-563, 2011.
- [13] N. Paton, "Prevention is better than cure," *Occupational Health & Wellbeing*, vol. 62, no. 6, pp.20, 2010.
- [14] R. Mendes, E. C. Dias, "Da Medicina do Trabalho a Saúde do Trabalhador," *Revista Saúde Públ.*, vol. 25, no. 5, pp. 341-349, 1991.
- [15] World Health Organization, "Ultraviolet radiation (UV): UV Index", 2002.