

# The Influence of Basalt and Steel Fibers on the Flexural Behavior of RC Beams

Yasmin Z. Murad, Haneen M. Abdl-Jabbar

**Abstract**—An experimental program is conducted in this research to investigate the influence of basalt fibers and steel fibers on the flexural behavior of RC beams. Reinforced concrete beams are constructed using steel fiber concrete and basalt fiber concrete. Steel and basalt fibers are included in a percentage of 15% and 2.5% of the total cement weight, respectively. Test results have shown that basalt fibers have increased the load carrying capacity of the beams up to 30% and the maximum deflection to almost 2.4 times that measured in the control specimen. It has also shown that steel fibers have increased the load carrying capacity of the beams up to 47% and the ultimate deflection is almost duplicated compared to the control beam. Steel and basalt fibers have increased the ductility of the reinforced concrete beams.

**Keywords**—Basalt fiber, steel fiber, reinforced concrete beams, flexural behavior.

## I. INTRODUCTION

REINFORCED concrete (RC) beams are mainly designed to resist vertical loads. The use of fiber RC has been recently extended in the construction of RC beams. Different types of fibers can be used in concrete mix. Fibers can enhance the mechanical and structural behavior of RC beams depending on the type, geometry, fiber percentage, orientation and distribution of the fibers. Steel fibers are one of the most common types of fibers that have been used recently to enhance the flexural behavior of RC beams. Flexural enhancement in RC beams depends on the percentage of steel fibers in the concrete mix. Fibers are usually added as a volumetric ratio of concrete or as a percentage of cement weight. Researchers have found that the optimum percentage of steel fibers in concrete mix is in a range of 1% to 1.5% of the concrete volume which is almost 10% to 15% of cement weight.

Fiber reinforced polymer (FRP) composites have become an accepted solution for strengthening and retrofitting RC structures. FRP have advantages over the other retrofitted materials due to its corrosion resistance, durability and flexibility [1]. Many researchers have conducted several experimental programs to investigate the experimental behavior of RC beams strengthened with FRP. Experimental programs conducted recently have shown that the configuration, orientation and properties of FRP can significantly influence the behavior of RC beams [2]–[5].

Strengthening RC beams can be performed externally by

applying FRP to the concrete surface or internally by using fibrous materials where FRP are added to the concrete mix. Experimental programs have shown the efficiency of fibers in enhancing the structural behavior of RC beams using internal or external FRP. Researchers have shown that the flexural strength of RC beams strengthened using externally bonded carbon fiber reinforced polymer (CFRP) has been significantly increased. Dong et al. [6] have shown that the flexural strength of RC beams has been increased in a range of 41–125% due to the presence of CFRP sheets.

An experimental program was conducted by Ashour and Garrity [7] where 16 strengthened RC continuous beams have been tested. The researchers have used several arrangements of internal steel bars and external CFRP laminates to strengthen the RC beams. The strengthened beams failed under different failure modes including laminate rupture, laminate separation and peeling failure of the concrete cover attached to the laminate. A significant loss in the ductility of the strengthened beams was observed compared to the unstrengthened control beam [7], [8].

Other experimental studies [10] have shown that RC beams strengthened with CFRP sheets have gained additional strength and ductility compared to the unstrengthened beams. It was also found that the direction of the reinforcing fibers can significantly influence the magnitude of the load increment and the failure mode of the strengthened beams. The maximum incremental strength was depicted in RC beams strengthened with CFRP sheets that were wrapped perpendicular to cracks in the beam while a brittle behavior is detected [10].

It is recommended to strengthen RC beams that are poor in flexure using CFRP sheets by wrapping them at the beam tension side [9]. Kharatmol et al have also shown that strengthening beams with CFRP sheets at their tension side was more efficient than strengthening RC beams at their two parallel sides [9].

Several researchers have shown the efficiency of steel fibers in increasing the load carrying capacity of RC beams. Behbahani et al. [11] have studied the flexural behavior of RC beams with different volumetric percentages of steel fibers including (0%, 0.5%, 1%, 1.5%, and 2%). It was shown that RC beams made with 1% steel fiber have the highest ultimate and cracking strength compared to all other test specimens. Altun et al. [12] have studied the flexural behavior of RC beams made with various dosages of steel fibers (0, 30, 60) kg/m<sup>3</sup> that have a length of 60 mm and a diameter of 0.75 mm. They have shown an increment in the flexural toughness and ultimate loads in the RC beams made with 30 kg/m<sup>3</sup> dosage of

steel fibers.

Basalt fibers are new inorganic fibrous material that have high tensile strength, good heat resistance, corrosion resistance, high chemical stability and low cost [13]. Basalt fibers have similar density to cement and can uniformly distributed making it with a good development prospect [13]. Singaravadivelan et al. [14] have studied the flexural behavior of RC beams using various percentages of basalt fibers including 0%, 0.5%, 1.0%, 1.5%, 2.0%, and 2.5% of concrete mixes. They have shown that the addition of basalt fibers has improved the flexural behavior of RC beams. Krassowska and Lapko [15] have shown that the addition of steel and basalt fibers can enhance the tensile strength of concrete. Fadil et al. [16] have shown that the addition of basalt fiber can enhance the flexural strength of RC beams.

This study experimentally investigates the flexural behavior of RC beams made with steel fibers and basalt fibers. It compares between the load carrying capacity, peak displacement, ultimate displacement, effective stiffness and mode of failure of the control specimen and the other specimens made with basalt and steel fibers.

## II. EXPERIMENTAL PROGRAM

### A. Material Properties

The ultimate and yield tensile strength of the longitudinal and transverse reinforcement are 400 MPa and 600 MPa, respectively. The average cubic concrete compressive strength of the test specimens is 33 MPa where the mix proportions are shown in Table I. The properties of steel and basalt fibers are shown in Table II. The selected basalt and steel fibers are shown in Figs. 1 (a) and (b), respectively.



Fig. 1 (a) Basalt fibers, (b) Steel fibers

Materials	Weight (Kg/m <sup>3</sup> )
Cement	325
Water	210
Fine aggregate	1070
Sand	690
Super – Plasticizer	1.195

### B. Specimen Details

Three simply supported RC beams have been tested under two point-loading where the distance between the load application points and that between the load application point and the support is 350 mm as shown in Fig. 2. The dimensions and the cross section of the test specimens are shown in Fig. 3

where the length of the beam is 1.2 m and the rectangular cross section is 150 mm x 250 mm.

TABLE II  
FIBER PROPERTIES

Properties	Steel Fibers	Basalt Fibers
Length	60 mm	60 mm
Diameter	0.75 mm	22 μm
Density	7.8 g/cm <sup>3</sup>	2.7 g/cm <sup>3</sup>
Aspect ratio (L/D)	80	2727.3
Tensile strength	1225 MPa	1380 MPa
Youngs modulus	200000 MPa	75 GPa

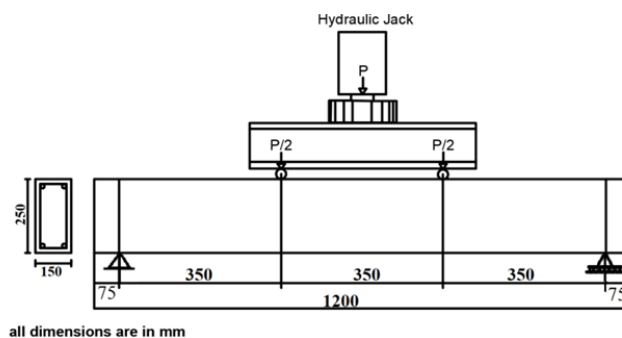

Fig. 2 Specimens details and test setup

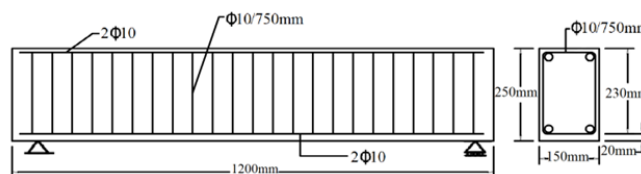

Fig. 3 Specimen details



Fig. 4 Test Setup

### C. Test Setup

The test setup is shown in Fig. 4 where all test specimens are simply supported with roller support at one end and pin support at the other side. The load is applied through a hydraulic jack that transfers the load to a rigid steel plate that is connected to two rigid steel cylinders that fixed at the loading points as shown in Fig. 4. A load cell is located between the hydraulic actuator and the loading collar to measure the load that is applied as force-controlled steps. The load application rate is 0.1 kN/second. Displacement

transducer (LVDT) is fixed at the beam mid span to measure the vertical mid-displacement.

### III. TEST RESULTS

The load-deflection curves and the failure modes of the test specimens are investigated in this section where a summary of the test results is shown in Table III. Table III illustrates the peak load, peak deflection, maximum deflection, load at first crack, effective stiffness (peak load/ deflection at peak load). The control specimen, which is made without fibers, has the lowest load carrying capacity of 89 kN and the lowest ultimate deflection of 8.31 mm. This specimen fails under flexural loading with some flexural shear cracking. Specimen FB11-B8 is made with 8 kg basalt that represents 2.5% of the cement weight. The load carrying capacity of this specimen is 113 kN which is 30% greater than that measured in the control specimen. The maximum deflection in specimen FB11-B8 is 19.2 mm which is almost 2.4 times that measured in the control specimen. Specimen FB7-S48 contains 48 kg of steel fiber which represents 15% of the total cement weight. The

load carrying capacity of this specimen has increased up to 130 kN which is almost 47% greater than that measured in the control specimen. The maximum deflection of this specimen is 17.11 mm which is almost double that measured in the control specimen.

### IV. BASALT FIBER EFFECT

Basalt fibers are new materials that have been recently used to enhance the mechanical properties of concrete. Basalt fibers are added in this research as 2.5% of the cement weight which is the maximum recommended percentage by basalt fiber's manufacturer. The addition of basalt fibers has increased the load carrying capacity of the RC beam up to 30% compared to the control specimen. It has also increased the ultimate deflection to approximately 2.4 that measured in the control specimen. Basalt fibers have increased the ductility of the beams where the effective stiffness (peak load/peak deflection) that shown in Table III has been decreased to 30% compared to the control specimen and the ultimate deflection has been increased significantly.

TABLE III  
TEST RESULTS

Specimen	Fiber	Fiber (%)	Peak load (KN)	Peak deflection	Ultimate displacement (mm)	Load at first crack (KN)	Effective stiffness (KN/mm)
FB1-C2	-	0	89	8.3	8.3	30	10.7
FB7-S48	steel	15	130	15.2	17.1	30	8.6
FB9-B8	basalt	2.5	113	16.5	19.2	40	6.8

The presence of basalt fibers have postponed the appearance of the first crack and delayed crack propagation. Vertical flexural cracks have extended from the beam's bottom surface propagating to the top. The major flexural crack appeared at the mid span of the beam which represents the point of the maximum bending moment. RC beams made with basalt fiber have failed due to flexural loading. The cracking load pattern at failure is shown in Fig. 5 (b).

flexural crack that extended from the beam's bottom surface to its top at its mid span.

### V. STEEL FIBER EFFECT

Steel fibers are one of the most common types of fibers that have been used widely to enhance the mechanical properties of concrete. The percentage of steel fibers is selected in this research based on the recommendation of the manufacturer (15% of the cement weight). The addition of steel fibers as 15% of the cement weight has increased the load carrying capacity of the test specimen up to 47% compared to the control specimen. The ultimate deflection has been duplicated compared to the control specimen due to the presence of steel fibers. Steel fibers have increased the ductility of the RC beams where the peak deflection has been increased significantly while the effective stiffness, that shown in Table III, has been decreased to the half compared to the control specimen.

The appearance of the first crack has been postponed in the specimen made with steel fibers and the propagation of the cracks has been delayed compared to the control specimen. The mode of failure of the specimen made with steel fibers is shown in Fig. 5 (c) where the specimen failed due to a major



(a) Control Beam

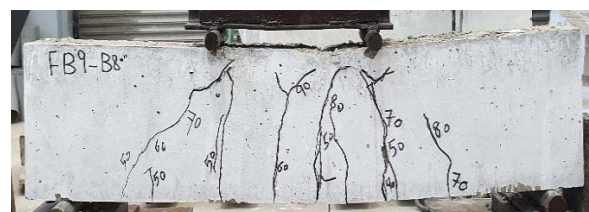

(b) FB9-B8

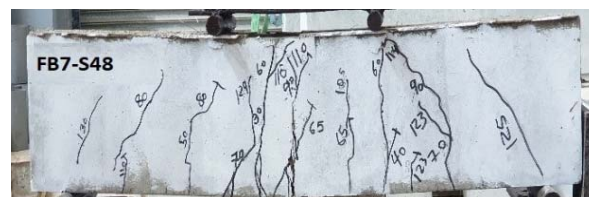

(c) FB7-S48

Fig. 5 Mode of failure

## VI. CONCLUSION

The influence of basalt fibers and steel fibers on the flexural behavior of RC beams is investigated in this research. The percentages of steel and basalt fibers considered in this research are 15% and 2.5% of the cement weight. The selected percentages are the maximum percentages that are recommended by the fiber's manufacturer. Test results have shown that steel and basalt fibers have increased the load carrying capacity of RC beams by 47% and 30%, respectively, compared to the control specimen. The presence of basalt fibers has increased the ultimate deflection 2.4 times that measured in the control specimens. Basalt fibers have also increased the ductility of the beam and reduced its effective stiffness. Steel fibers have also increased the ductility of the specimens, duplicated the peak deflection and reduced the effective stiffness.

Both types of fibers have postponed the appearance and propagation of the flexural cracks.

## ACKNOWLEDGMENT

The authors would like to thank the deanship of academic research at the University of Jordan for their financial support to perform this research.

## REFERENCES

- [1] L. L. Away, "Key issues in the use of fibre reinforced polymer (FRP) composites in the rehabilitation and retrofitting of concrete structures."
- [2] Y. Murad, "The influence of CFRP orientation angle on the shear strength of RC beams," *Open Constr. Build. Technol. J.*, vol. 12, 2018.
- [3] Yasmin Murad, "An experimental study on flexural strengthening of RC beams using CFRP sheets," *Int. J. Eng. Technol.*, vol. 7, pp. 2075–2080, 2018.
- [4] A. Mofidi and O. Chaallal, "Tests and Design Provisions for Reinforced-Concrete Beams Strengthened in Shear Using FRP Sheets and Strips," *Int. J. Concr. Struct. Mater.*, vol. 8, no. 2, pp. 117–128, Jun. 2014.
- [5] A. K. Samanta, D. K. Singha Roy, J. V. Thanikal, N. Aravind, and S. Roy, "Retrofitting of reinforced concrete beams using fibre reinforced polymer (FRP) composites – A review," *J. Urban Environ. Eng. J. Urban Environ. Eng. J. Urban Environ. Eng.*, no. 71, pp. 164–175, 2013.
- [6] J. Dong, Q. Wang, D. He, and Zhongwei Guan, "CFRP sheets for flexural strengthening of RC beams," in *2011 International Conference on Multimedia Technology*, 2011, pp. 1000–1003.
- [7] A. Ashour, S. El-Refaie, and S. Garrity, "Flexural strengthening of RC continuous beams using CFRP laminates," *Cem. Concr. Compos.*, vol. 26, no. 7, pp. 765–775, Oct. 2004.
- [8] M. M. Önal, "Strengthening Reinforced Concrete Beams with CFRP and GFRP," *Adv. Mater. Sci. Eng.*, vol. 2014, pp. 1–8, Jul. 2014.
- [9] R. Kharatmol, P. Sananse, R. Tambe, M. Raksha, and J. Khare, "Strengthening of Beams Using Carbon Fibre Reinforced Polymer," *Int. J. Emerg. Eng. Res. Technol.*, vol. 2, no. 3, pp. 119–125, 2014.
- [10] T. Norris, H. Saadatmanesh, and M. R. Ehsani, "Shear and Flexural Strengthening of R/C Beams with Carbon Fiber Sheets," *J. Struct. Eng.*, vol. 123, no. 7, pp. 903–911, Jul. 1997.
- [11] H. P. Behbahani, B. Nematollahi, A. R. Mohd, and F. C. L. Sam, *International journal of sustainable construction engineering technology*. Penerbit UTHM, Universiti Tun Hussein Onn Malaysia.
- [12] F. Altun, T. Haktanir, and K. Ari, "Effects of steel fiber addition on mechanical properties of concrete and RC beams," *Constr. Build. Mater.*, vol. 21, no. 3, pp. 654–661, Mar. 2007.
- [13] M. Abdulhadi, "A comparative Study of Basalt and Polypropylene Fibers Reinforced Concrete on Compressive and Tensile Behavior," *Int. J. Eng. Trends Technol.*, vol. 9, no. 6, 2014.
- [14] R. Singaravadivelan, P. Chinnadurai, K. L. Muthuramu, and P. Vincent, "Flexural Behaviour of Basalt Chopped Strands Fiber Reinforced Concrete Beams," in *2nd International Conference on Chemical,*

*Ecology and Environmental Science*, 2013.

- [15] J. Krassowska and A. Lapko, "The Influence of Steel and Basalt Fibers on the Shear and Flexural Capacity of Reinforced Concrete Beams," 2013.
- [16] D. Fadil, N. Taysi, and A. Ahmed, "The Investigation of Basalt and Glass Fibers on the Behavior of Reinforced Concrete Beams," 2018.