

Influence of Power Flow Controller on Energy Transaction Charges in Restructured Power System

Manisha Dubey, Gaurav Gupta, Anoop Arya

Abstract—The demand for power supply increases day by day in developing countries like India henceforth demand of reactive power support in the form of ancillary services provider also has been increased. The multi-line and multi-type Flexible alternating current transmission system (FACTS) controllers are playing a vital role to regulate power flow through the transmission line. Unified power flow controller and interline power flow controller can be utilized to control reactive power flow through the transmission line. In a restructured power system, the demand of such controller is being popular due to their inherent capability. The transmission pricing by using reactive power cost allocation through modified matrix methodology has been proposed. The FACTS technologies have quite costly assembly, so it is very useful to apportion the expenses throughout the restructured electricity industry. Therefore, in this work, after embedding the FACTS devices into load flow, the impact on the costs allocated to users in fraction to the transmission framework utilization has been analyzed. From the obtained results, it is clear that the total cost recovery is enhanced towards the Reactive Power flow through the different transmission line for 5 bus test system. The fair pricing policy towards reactive power can be achieved by the proposed method incorporating FACTS controller towards cost recovery of the transmission network.

Keywords—Inter line power flow controller, Transmission Pricing, Unified power flow controller, cost allocation.

I. INTRODUCTION

THE electric power exchange across the world experiencing change from regulated to deregulated structure. Due to competition among utilities and contracts between producer and consumer in the inter-connected network, unplanned power exchanges increase. The various methods of transmission pricing based on the allocation of network utilization have become important under such circumstances and effect on that with FACTS controller need to be analyzed. Congestion in a transmission line may happen if these trades are not controlled and very much arranged. Development of new lines would turn out to be uneconomical and a repetitive procedure. Hence, we have to get an alternative method for controlling power in order to permit more productive and better utilization of available transmission network by employing FACTS. A noteworthy push of FACTS innovation is the improvement of the transmission network that gives dynamic control of the power exchange like transmission voltage, line impedance and load angle. In the transmission network, FACTS is turning into a basic part to control power

flow nearer to the thermal limits of the transmission line. In recent years, the demand for electricity increases day by day but the transmission facilities are not installed to fulfill this demand due to this, the transmission line is heavily loaded and may lead to line outage. Hence, the incorporation of FACTS devices in the transmission system can be reliable to deal with this situation. By incorporating these devices into the system reactive power support and power flow through the line can be controlled so the stability of the transmission system can be enhanced. There are two ways to employ FACTS devices in the transmission system; one way is to install voltage source converter operating in the self-commutation principle and another way is to use a Thyristor controlled reactor or capacitor. For the series compensation scheme, TCSC can be used while for shunt compensation either STATCOM or UPFC can be used. For the mathematical modeling of FACTS devices voltage source modeling concept and power injection modeling concept is used. Further according to the need, they can be connected in series or shunt manner and combination of both.

Murthy discussed the modeling of voltage-dependent loads in Newton Raphson load flow algorithm [1]. From the economic point of view, the installation of FACTS devices is very costly. Hence, in the restructured power market, this cost also recovered from the users. El-Hawary and Dias [2], [4] have considered loads (which actually comprise of residential, industrial and commercial loads) are not independent of voltage variations and have a significant effect on load flow results. Dias and El-Hawary also studied the sensitivity of bus bars to variations in load model parameters [3]. Dias et al. analyzed the behavior of voltage-dependent loads in optimal load flow studies [5]. The virtual flow methodology for the assessment of the flow of reactive power in transmission network due to different sources and particular load involvement with consideration of counter and loop flows without any difficulty has been addressed [7], [8]. By incorporating these models, the power flow solution can be achieved. The Newton Raphson algorithm for the large power system with FACTS devices and DC load flow model with UPFC for restructured power systems are discussed in [9], [15], respectively. A method based on tracing of electrical power has been reported [10], [11], which has the assumption that outflow and inflow on nodes are proportionally shared. The actual dimensions of the mismatch vector and Jacobian may not be altered. This is the fundamental advantage of the power injection model; however, due to lack of information about the active power line losses this model is less accessible [12], [20]. The controllable voltage over an indistinguishable

Manisha Dubey, Gaurav Gupta, and Anoop Arya are with the Electrical Engineering Department, Maulana Azad National Institute of Technology, Bhopal, India (e-mail: manishadubey6@gmail.com, gauravmits@gmail.com, anooparya.nitb@gmail.com).

capacitive or inductive range autonomous of the line current can be obtained practically by using GTO based voltage source inverter. The power injection model concept is based on the conversion of the voltage source in terms of active and reactive power injected at nodes [14]. The reactive power transacted through transmission line [16] needs to be traced for apportioned the wheeling charges. A tracing based reactive power flow is reported by Bialek and Kattuman [17] with upward and downward looking principle. This can be utilized for cost allocation [18]. The network configuration to incorporate FACTS Controller based on voltage source modeling has been presented by Acha et al. [19]. The application of particle swarm optimization (PSO) technique to find the optimal location and minimum cost of installation of FACTS devices and to improve system loadability (SL). While finding the optimal location, the thermal limit for the lines and voltage limit for the buses are taken as constraints has been presented by Saravanan et al. [21]. The Z-bus matrix and modified Y-bus matrix methods treated as circuit-based allocation methods, all the computation in these methods are based on the admittance matrix to solved power flow [22], [24]-[26]. A differential evolution algorithm (DEA) based allocation of FACTS devices considering cost function and power system losses to improve security margin has been presented by Baghaee et al. [23]. The corrective solution for congestion management by using TCSC has been reviewed along with genetic algorithm-based approach for finding the optimal location and size of FACTS device for congestion management with the aim of increasing social welfare while the cost of TCSC was incorporated by Hosseinipoor et al. [27]. Determination of generator contribution can be used for congestion management [29], [30]. An enhanced PSO based optimization for optimizing the power system losses and voltage profiles has been proposed by Ravi et al. [31]. The investigation towards the implementation of integrated evolutionary algorithms for solving the capacitor placement optimization problem with reduced annual operating cost has been presented by El-Fergany [32]. Almost all of these solutions [33], [35] suggest that transmission utilization wage seems to have the power transmission loss charge as being an essential component of the transmission system, so it really does not require an additional computation. Bhattacharyya et al. offered the Differential Evolution Approach to apportion and facilitate its implementation with various FACTS technologies to an interconnected energy system [34]. Voltage saddle-node points with facts device along with Static Var Compensator (SVC) to enhance the voltage profile with the most appropriate placement of SVC and sizing of SVC using an evolutionary approach like Genetic algorithm (GA) has been inspecting by Srikanth et al. [36].

II. FACT CONTROLLER MATHEMATICAL MODELING

A. Modeling of IPFC

The problem of low reactance to resistive ratio can be overcome by incorporating the interline power flow controller scheme. The capability of the scheme is to manage power

transmission in multi-line of a substation.

By joining at least two or more arrangement of series-connected converters functioning collectively, the IPFC extend the ideas of voltage and power flow control ahead of that attainable by the one-converter of the FACTS controller, the Static Synchronous Series Compensator (SSSC) as shown in Fig. 1. In the IPFC arrangement, various converters are connected to together at their DC terminals. Every converter can give series reactive compensation, as an SSSC, for its own particular line. However, the inverters can exchange real power between them through their ordinary DC terminal. This ability enables the IPFC to offer both reactive and real compensation for a portion of the lines and, consequently, enhance the usage of general transmission frameworks. Real power can be extracted from one line and injected into another. Thusly, dissimilar to the SSSC, the injected voltage does not need to be in quadrature with the line current. This inferred that magnitude of voltage and phase angle together regulate injected voltage of the one line. However,

For proper operation of the device, the DC bus voltage must be held constant and the real power, injected to one line by the Voltage Source Converter (VSC), must be equal to the real power extracted from the other line. Hence, only one of the variables of the injected voltage of the other line can be independently controlled. Like other FACTS elements, IPFC can be used for increasing power system stability against large and small disturbances.

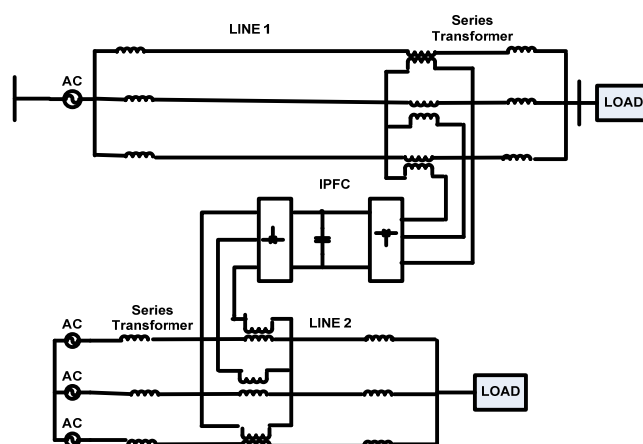

Fig. 1 Schematic diagram of IPFC

B. Modeling of UPFC

The unified power flow controller is a combination of two voltage source converters in which one converter connected in series and another converter connected in shunt with transmission line through the transformer at both side and a D.C. link capacitor in between. This arrangement simultaneously and selectively able to control parameters such as voltage magnitude, line impedance and phase angle etc. so the capability of multifunctional makes this device unified. The set of synchronous voltages of magnitude V_{se} and their angle inject in the transmission line is fully controllable by converter connected in series with the line [14, 19].

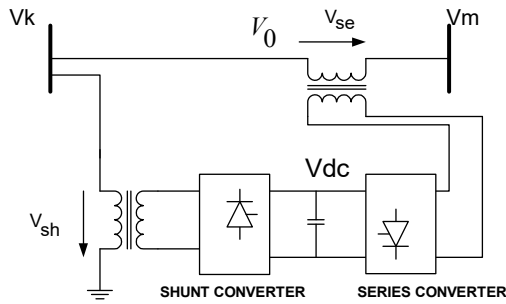

Fig. 2 Schematic diagram of UPFC

The active power required by the series converter at common DC link is given through by means of converter connected in shunt in the transmission line. Shunt converter also has the capability to independently regulate reactive power demanded or absorb by the line [19].

The converters connected in series with the line can be represented by an ideal voltage source with the magnitude V_{se} at an angle θ_{se} between buses k and m and another converter connected in shunt with the line injected voltage V_{sh} at an angle θ_{sh} as shown in Fig. 3. The impedances in series with the voltage source represent the losses caused by the coupling transformer. The mathematical equations for the ideal voltage source converter upfc equivalent circuit are [14], [19].

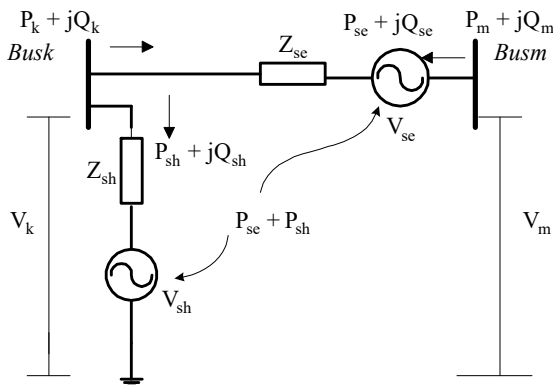

Fig. 3 UPFC Equivalent Circuit

$$V_{se} = V_{se}(\cos\theta_{se} + j\sin\theta_{se}) \quad (1)$$

$$V_{sh} = V_{sh}(\cos\theta_{sh} + j\sin\theta_{sh}) \quad (2)$$

The power flow equation with UPFC between buses k and m are given by

$$P_{km} = V_k^2 G_{kk} + V_k V_m G_{km} \cos(\theta_k - \theta_m) + V_k V_{se} G_{km} \cos(\theta_k - \theta_{se}) + V_k V_{sh} G_{sh} \cos(\theta_k - \theta_{sh}) + V_k V_m B_{km} \sin(\theta_k - \theta_m) + V_k V_{se} B_{km} \sin(\theta_k - \theta_{se}) + V_k V_{sh} B_{sh} \sin(\theta_k - \theta_{sh}) \quad (3)$$

$$Q_{km} = -V_k^2 B_{kk} + V_k V_m B_{km} \cos(\theta_k - \theta_m) + V_k V_{se} B_{km} \cos(\theta_k - \theta_{se})$$

$$+ V_k V_{sh} B_{sh} \cos(\theta_k - \theta_{sh}) + V_k V_m G_{km} \sin(\theta_k - \theta_m) + V_k V_{se} G_{km} \sin(\theta_k - \theta_{se}) + V_k V_{sh} G_{sh} \sin(\theta_k - \theta_{sh}) \quad (4)$$

$$P_{mk} = V_m^2 G_{mm} + V_m V_k G_{mk} \cos(\theta_m - \theta_k) + V_m V_{se} G_{mm} \cos(\theta_m - \theta_{se}) + V_m V_k B_{mk} \sin(\theta_m - \theta_k) + V_m V_{se} B_{mm} \sin(\theta_m - \theta_{se}) \quad (5)$$

$$Q_{mk} = -V_m^2 B_{mm} - V_m V_k B_{mk} \cos(\theta_m - \theta_k) - V_m V_{se} B_{mm} \cos(\theta_m - \theta_{se}) + V_m V_k G_{mk} \sin(\theta_m - \theta_k) + V_m V_{se} G_{mm} \sin(\theta_m - \theta_{se}) \quad (6)$$

where

$$y_{se} = \frac{1}{Z_{se}}, \quad y_{sh} = \frac{1}{Z_{sh}}$$

and

$$G_{kk} + jB_{kk} = y_{se} + y_{sh} = Y_{kk}$$

$$G_{mm} + jB_{mm} = y_{se} = Y_{mm}$$

$$G_{km} + jB_{km} = -y_{se} = Y_{km} = Y_{mk}$$

$$G_{sh} + jB_{sh} = -y_{sh} = Y_{sh}$$

The modeling of UPFC with voltage source model carried out here with the assumption that converters are lossless. Hence the voltage across DC link capacitor remains constant and power demanded by series converter P_{se} is equal to power supplied through shunt converter P_{sh} so relation for equality constant can be represented by the following equation.

$$P_{se} + P_{sh} = 0 \quad (7)$$

where

$$P_{se} = V_{se}^2 G_{mm} + V_{se} V_k (G_{km} \cos(\theta_{se} - \theta_k) + B_{km} \sin(\theta_{se} - \theta_k)) + V_{se} V_m (G_{mm} \cos(\theta_{se} - \theta_k) + B_{mm} \sin(\theta_{se} - \theta_m)) \quad (8)$$

$$P_{sh} = -V_{sh}^2 G_{sh} + V_{sh} V_k (G_{sh} \cos(\theta_{sh} - \theta_k) + B_{sh} \sin(\theta_{sh} - \theta_k)) \quad (9)$$

To carry out power flow analysis, the Newton-Raphson method is adapted with UPFC. For that, the power equation is modified with a combination of the network equation. The voltage magnitude at bus k can be used as a parameter to regulate power flow from bus m to k , the mathematical equation for both the buses are as [14], [19].

$$P_k + jQ_k = \sum_{j=1}^n V_k V_j Y_{kj} \angle(\theta_{kj} - \delta_k + \delta_j) + P_{km} + jQ_{km} \quad (10)$$

$$P_m + jQ_m = \sum_{j=1}^n V_m V_j Y_{kj} \angle(\theta_{kj} - \delta_k + \delta_j) + P_{mk} + jQ_{mk} \quad (11)$$

$$P_k = \sum_{j=1}^n B_{kj}(\delta_k - \delta_j) + B_{km}(\theta_k - \theta_m) + B_{nk}(\theta_k - \theta_{se}) + B_{sh}(\theta_k - \theta_{se}) \quad (12)$$

Equations (10) and (11) can be linearised with respect to the parameter of the system and UPFC. By regulating the parameter Vse and θ_{se} simultaneously with inclusion in Jacobian targeted value of power flow between buses m and k (P_{mk} and Q_{mk}) can be achieved. Power flow convergence is achieved when the equation of power does not mismatch.

III. TRANSMISSION PRICING MODELLING

C. Model for Tracing of Reactive Power Flow and Allocation

Let $l_n = 1, \dots, e$ show the entire transmission line in the power system structured, $G_n = 1, \dots, g$ is the entire quantity of generating units and $D = 1, \dots, d$ is the entire quantity of users in the structure. Again, generation in diagonal form can be represented as $P_{GG} = \text{diag}(P_{G1}, P_{G2}, \dots, P_{Gn})$. Thus, from [13], [28]

$$U = K_m^{-1} P_L \quad (13)$$

$$U^T P_{GG} = (P_G)^T \text{ or } P_G = P_{GG} U \quad (14)$$

By combining (13) and (14)

$$P_G = P_{GG} K_m^{-1} P_L \quad (15)$$

Obtained matrix $P_{GG} K_m^{-1}$ is called generation production matrix. The generation production matrix is indicated by GPM = (t_{ij}) , i.e., where,

$$\text{GPM} = P_{GG} K_m^{-1} \quad (16)$$

$$R_{i \rightarrow j} = t_{ij} R_{Lj} \quad (17)$$

Here $t_{ij} R_{Lj}$ represents the reactive flow contribution of generator situated at bus i to the load at bus j. Reactive power allocated to generator placed at bus i share the line s – b can be calculated by,

$$RP_{i \rightarrow s-b} = t_{is} r_{f_{s-b}} \quad (18)$$

To obtain the contribution of reactive power by loads, similar procedure is repeated. To Determine the power extracted by individual load from the line flow, extraction factor matrix of loads to generators has been utilized which expressed by EFM

$$\text{EFM} = (P_{LL} K_m^{-1})^T \quad (19)$$

where the diagonal matrix $P_{LL} = \text{diag}(P_{L1}, P_{L2}, \dots, P_{Ld})$ [6].

In this paper, the author assumed that the expense occurred for the transaction of reactive power should be recovered from the consumer or load participant. By using extraction factor matrix reactive power allocated to load is obtained for 5 bus test system.

D. Cost Allocation Model for Reactive Flows

For allocation of reactive power cost, the following algorithm is developed. For this purpose, the MVAR-mile method is used. In this model, the reactive power charge is allocated with respect to the reactive power base capacity of the transmission line [6], [28].

If the cost of the line is denoted as TC_{s-b} (in Rs/hr), then reactive power cost allocated to users is given by:

For Load L_h full transmission usage cost allocation is given by,

$$\text{FTRC}_{s-b}^{L_h} = \frac{RP_{j \rightarrow s-b}}{rf_{base\ s-b}} \times TC_{s-b} \quad (20)$$

Total transmission Usage cost $TRC_f^{L_h}$ allocated to Load L_h

$$TRC_f^{L_h} = \sum_{ln=1}^e \text{FTRC}_{ln}^{L_h} \quad (21)$$

IV. RESULT AND DISCUSSION

The 5 bus system has two generators and three loads with seven transmission line. For cost allocation, it is assumed that the cost of the transmission lines is proportional to the length of the lines.

E. 5 Bus System

Reactive power flow through the different transmission line and cost allocation towards the reactive power wheeling charges from the different load participants for 5-bus system without FACT controller are given in Table I and with UPFC is given in Table II.

From Fig. 4, it is clear that the total cost recovery is enhanced by 26% towards the reactive power flow through the different transmission line for 5-bus test system.

V. CONCLUSION

The demand for power supply increases day by day in developing countries like India, so the demand for reactive power support in the form of ancillary services provider also has been increased. The fair pricing policy towards reactive power can be achieved by the proposed method incorporating FACTS controller towards cost recovery of the transmission network. From the result shown in Tables I and II for 5-bus system, it is clear that the reactive power flow through the transmission line can be regulated effectively. The influence of the FACT controller on the transaction cost of reactive power which will be recovered from the different load participant in the network has been analyzed. The implementation of the proposed method on the 5-bus system

shows the impact of FACTS controllers in terms of cost recovery enhancement.

TABLE I
REACTIVE POWER AND COST ALLOCATION WITHOUT FACT CONTROLLER

Line No.	Reactive Power Flows in P.U.	MVAR to L3	MVAR to L4	MVAR to L5	MVAR Transaction Cost in Rs/hr	Cost Allocated to L3	Cost Allocated to L4	Cost Allocated to L5
1-2	0.7916	0.2757	0.2072	0.2794	63.25	17.44	13.11	17.67
1-3	0.1757	0.0612	0.0460	0.0620	252.98	15.48	11.64	15.69
2-3	0.0297	0.0048	0.0082	0.0156	189.74	0.91	1.55	2.95
2-4	0.0207	0.0033	0.0057	0.0108	189.74	0.63	1.08	2.06
2-5	0.0541	0.0087	0.0149	0.0283	126.49	1.10	1.89	3.58
3-4	0.0351	0.0245	0.0083	0.0012	31.62	0.77	0.26	0.04
4-5	0.0072	0	0.0062	0.0009	252.98	0.00	1.56	0.23
Total						36.33	31.09	42.22

TABLE II
REACTIVE POWER AND COST ALLOCATION WITH FACT CONTROLLER

Line No.	Reactive Power Flows in P.U.	MVAR to L3	MVAR to L4	MVAR to L5	MVAR Transaction Cost in Rs/hr	Cost Allocated to L3	Cost Allocated to L4	Cost Allocated to L5
1-2	0.8258	0.2876	0.2164	0.2915	63.25	18.19	18.43	18.47
1-3	0.1488	0.0518	0.0390	0.0525	252.98	13.11	9.86	13.28
2-3	0.0791	0.0128	0.0218	0.0414	189.74	2.42	4.13	7.86
2-4	0.0473	0.0076	0.013	0.0248	189.74	1.45	2.47	4.7
2-5	0.0716	0.0115	0.0197	0.0375	126.49	1.46	2.49	4.74
3-4	0.182	0.1266	0.0433	0.0066	31.62	4	1.37	0.21
4-5	0.0674	0	0.0576	0.0088	252.98	0.00	1.457	2.23
Total						40.63	54.88	53.69

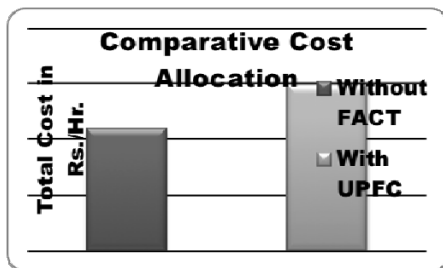

Fig. 4 Comparative Cost Allocation

REFERENCES

[1] P.S.R.Murty, "Load modeling for power flow solutions", J. Inst. Eng. (India) Electr. Eng. Div., vol.58, pp. 162-165, 1977.
 [2] M.E. El-Hawary, and L.G.Dias, "Incorporation of load models in load-flow studies: form of model effects", IEE Proc. C, Gen. Trans. & Distrib., vol.134, no.1, pp. 27-30, 1987.
 [3] M.E. El-Hawary, and L.G.Dias, "Bus Sensitivity to load model parameters in Load -flow Studies", IEE Proc. C Generation Transmission and distribution. vol.134, no.4, pp. 302-305, 1987.
 [4] M.E. El-Hawary, and L.G.Dias, "Selection of buses for detailed modeling in load flow studies", Electr. Mach. Power Syst., vol.12, pp. 83-92, 1987.
 [5] L.G.Dias, M.E.El-Hawary, " Effects of active and reactive power modeling in optimal load flow studies" IEE Proc., vol. 136, Pt C, No.5, pp 259-263, Sept 1989.
 [6] Baughman, M. L. and Siddiqi, S. N., " Real Time Pricing of Reactive Power: Theory and Case Study Results ", IEEE Trans. on Power Systems, vol. 6, no.1, pp. 23-29, 1991.
 [7] Hogan, W., "Markets in Real Electric Networks Require Reactive Prices", The Energy Journal, vol.14, no.3 pp.171-200, 1993.
 [8] Wood, A.J., and Wollenberg, B.F., "Power generation, operation, and control", Wiley & Sons, New York, 2nd Edn., 1996.
 [9] Fuerte Esquivel C.R. and E.Acha, "Newton-Raphson algorithm for the reliable solution of large power networks with embedded FACTS", IEE Proc.-Gan. Tvansnr. Distrib., vol.143, no. 5, pp. 447-454, 1996.

[10] Schweppe, F. C., M. C. Caramanis, R. D. Tabors, and R. E. Bohn, "Spot Pricing of Electricity", Kluwer Academic Publishers, Boston. 1998.
 [11] J. W. Lamont and J. Fu, " Cost analysis of reactive power support ", IEEE Transactions on Power Systems, vol. 14, no. 3, pp. 890-898, Aug. 1999.
 [12] Y. H. Song, J.Y. Liu, P.A. Mehta, " Power injection modeling and optimal multiplier power flow algorithm for steady-state studies of unified power flow controllers", Electric Power System Research, vol.52, pp. 51-59, 1999.
 [13] F. Gubina, D. Grgic and I. Banic, "A method for determining the generators share in a consumer load ", IEEE Transactions on Power Systems, vol. 15, no. 4, pp. 1376-1381, 2000.
 [14] N. G. Hingorani and L. Gyugyi, "Understanding FACTS", New York: IEEE Press, 2000.
 [15] C. R. Fuerte-Esquivel, E. Acha, and H. Ambriz-Prez, "A comprehensive Newton-Raphson UPFC model for the quadratic power flow solution for practical power networks", IEEE Transactions on Power Systems., vol. 15, pp.102-109, Feb. 2000.
 [16] Peter W. Sauer. What is Reactive power? Power Systems Engineering Research Center, Department of Electrical and Computer Engineering, University of Illinois at Urbana- Champaign, September 16, 2003.
 [17] Y. Dai, X.D. Liu, Y.X. Ni, F.S. Wen, Z.X. Han, C.M. Shen, Felix F. Wu, " A cost allocation method for reactive power service based on power flow tracing", Electric Power Systems Research, vol.64, pp.59-65, 2003.
 [18] Bialek J.W., Kattuman P.A., "Proportional sharing assumption in tracing methodology", IEE Proceedings Generation transmission Distribution, vol.151, no.4, pp.526-532, July 2004.
 [19] Enrique Acha, Fuerte-Esquivel Claudio R, Ambize-Perez H, Angeles-Camacho C. " FACTS: modelling and simulation in power networks", John Wiley & Sons, Ltd. ISBN: 0-470-85271-2,2004.
 [20] Nemat Talebi, M. Ehsan and S. M. T. Bathaee, "An Efficient Power Injection Modeling and Sequential Power Flow Algorithm for FACTS Devices", IEEE SoutheastCon, 2004. Proceedings. Greensboro, North Carolina, USA, pp. 97-104, 2004.
 [21] M. Saravanan, S. Mary Raja Slochanal, P. Venkatesh, J. Prince Stephen Abraham, "Application of particle swarm optimization technique for optimal location of FACTS devices considering cost of installation and system loadability", Electric Power Systems Research, vol. 77, issues 3-4, pp. 276-283, March 2007.

- [22] Hussain Shareef, Mohd. Wazir Mustafa, Saifulnizam Abd Khalid, Azhar Khairuddin, Akhtar Kalam, Amanullah Maung Than Oo, "Real and Reactive Power Transfer Allocation Utilizing Modified Nodal Equations", International Journal of Emerging Electric Power Systems, vol. 9, no. 6, article 4, 2008.
- [23] H. R. Baghaee, B. Vahidi, S. Jazebi, G. B. Gharehpetian and A. Kashefi, "Power System Security Improvement by Using Differential Evolution Algorithm Based FACTS Allocation ", 2008 Joint International Conference on Power System Technology and IEEE Power India Conference, New Delhi, pp. 1-6, 2008.
- [24] Abdorreza Rabiee, Haidor Alishayanfer, Nibamjady Iee, "Power and Engineering Magazine", pp.18-32, January/February 2009.
- [25] Kaigui Xie, Jiaqi Zhou, Wenyuan Li "Analytical model and algorithm for tracing active power flow based on extended incidence matrix", Electric Power Systems Research, vol.79, pp. 399-405, 2009.
- [26] D. Thukaram and C. Vyjayanthi, "Relative electrical distance concept for evaluation of network reactive power and loss contributions in a deregulated system", IET Gener. Transm. Distrib., vol. 3, no.11, pp. 1000-1019, 2009.
- [27] N. A. Hosseinipoor and S. M. H. Nabavi, "Social Welfare Maximization by Optimal Locating and Sizing of TCSC for Congestion Management in Deregulated Power Markets", 2010 International Conference on Power System Technology (POWERCON), Hangzhou, pp. 1-5, 24-28 October 2010.
- [28] Seyed Mohammad, Hossein Nabavi, Somayeh Hajforoosh, Sajad Hajforosh, Nazanin Alsadat Hosseinipoor, "Using Tracing Method for Calculation and Allocation of Reactive Power Cost ", International Journal of Computer Applications, vol. 13, no. 2, pp.14-17, 2011.
- [29] Sawan Sen, Priyanka Roy, Abhijit Chakrabarti, Samarjit Sengupta "Generator Contribution Based Congestion Management using Multiobjective Genetic Algorithm ", TELKOMNIKA, vol.9, no.1, pp. 1-8, April 2011.
- [30] Hermagasantos Zein, Erwin Dermawan "Cost Allocation of Transmission Losses in Electric Market Mechanism" ,TELKOMNIKA, vol.10, no.2, , pp. 211-218, June 2012.
- [31] K. Ravi and M. Rajaram, " Optimal location of FACTS devices using enhanced particle swarm optimization ", 2012 IEEE International Conference on Advanced Communication Control and Computing Technologies (ICACCCT), Ramanathapuram, pp. 414-419, 2012.
- [32] A. A. El-Fergany, " Optimal capacitor allocations using evolutionary algorithms", in IET Generation, Transmission & Distribution, vol. 7, no. 6, pp. 593-601, June 2013.
- [33] Harinder Pal Singh, Yadwinder Singh Brar, D. P. Kothari, "Combined Active and Reactive Power Dispatch Using Particle Swarm Optimization", Proceedings of Informing Science & IT Education Conference (InSITE) 2014.
- [34] B. Bhattacharyya, V. K. Gupta and S. Das " Evolutionary Programming for Reactive Power Planning Using FACTS Devices ", WSEAS Transactions on Power Systems, vol. 9, 2014.
- [35] Enshae A., Enshae P., " New reactive power flow tracing and loss allocation algorithm for grids using matrix calculation ", Electric Power and Energy System, vol.87,pp.89-98,2017.
- [36] B.V. Srikanth and A. Lakshmi Devi " Optimal location and sizing of SVC using genetic algorithm to find voltage saddle node points for improving voltage stability", International Journal of Pure and Applied Mathematics, vol. 114, no. 12, pp. 477-489, 2017.