

Intelligent Parking Systems for Quasi-Close Communities

Ayodele Adekunle Faiyetole, Olumide Olawale Jegede

Abstract—This paper presents the experimental design and needs justifications for a localized intelligent parking system (L-IPS), ideal for quasi-close communities with increasing vehicular volume that depends on limited or constant parking facilities. For a constant supply in parking facilities, the demand for an increasing vehicular volume could lead to poor time conservation or extended travel time, traffic congestion or impeded mobility, and safety issues. Increased negative environmental and economic externalities are other associated and consequent downsides of disparities in demand and supply. This L-IPS is designed using a microcontroller, ultrasonic sensors, LED indicators, such that the current status, in terms of parking spots availability, can be known from the main entrance to the community or a parking zone on a LCD screen. As an advanced traffic management system (ATMS), the L-IPS is designed to resolve aspects of infrastructure-to-driver (I2D) communication and parking detection issues. Thus, this L-IPS can act as a timesaver for users by helping them know the availability of parking spots. Providing on-time, informed routing, to a next preference or seamless moving to berth on the available spot on a proximate facility as the case may be. Its use could also increase safety and increase mobility, and fuel savings and costs, therefore, reducing negative environmental and economic externalities due to transportation systems.

Keywords—Intelligent parking systems, localized intelligent parking system, intelligent transport systems, advanced traffic management systems, infrastructure-to-drivers communication.

I. INTRODUCTION

WITH the significant increase in vehicular volume over time in any built, and even in a non-built environment that is rapidly urbanizing, there are accompanied intense demands for the limited or near constant supply of parking facilities. Rapid urbanization is the result of large net population increase and economic prosperity, which has serious implications for land-use patterns. As Tole [1] pointed out, urban planners have tagged each piece of land for a particular use, which of course may be encroached into for other forms of utilization *ab initio* unintended. Municipalities, however, frown at distorting their urban planning blueprints to the extent that huge fees and penalties are imposed on defaulters to discourage such practices. And considering that land is a limited resource, it is pertinent to make the best use of the piece of land that has been apportioned for specific purposes, which is increasingly achieved through the concept

Ayodele Adekunle Faiyetole is with the Department of Transport Management Technology, Federal University of Technology Akure, PMB 704 Akure and with the Air, Space, and Intelligent Transport Systems Unit, EarthSpace, P.O. Box 20200 Ikeja, Lagos, Nigeria (e-mail: aafaiyetole@futa.edu.ng).

Olumide Olawale Jegede is with the Department of Transport Management Technology, Federal University of Technology, Akure, Nigeria.

of ‘smart cities.’

With the rapid urbanization caused by net population increase and economic prosperity, there is a consequent rise in vehicular volume. Idris et al. [2], [3] revealed that in Malaysia, the increase in vehicular volume over a span of seven years is approximately 54.5% (with 296,716 new vehicles registered in 1999 and 458,293 in 2006), implying that there is a need for more or efficient parking infrastructure within or outside the scope of the land use pattern. This is even more critical in a quasi-close community of rapidly urbanizing non-built or built environment, which is usually gated with monitoring personnel or devices for in- and out- movement; the land use laws are, thus, strictly adhered to, and land-use pattern properly controlled. Thus, a portion of the piece of land that has been earmarked as a parking facility could have limited expansion despite a possible surge in the net population of such community, of which supply may soon become constant due to the competing needs of other equally or more important purposes.

Quasi-close communities are in different categories, from residential estates to university campuses. This study has, however, considered a university campus in southwestern Nigeria, the Federal University of Technology, Akure (FUTA), as the area of focus, as a good candidate of a quasi-close community. Established in 1981, with the teaching of the first enrollment of 149 students starting on 22 November 1982, the university started with three schools, and now in 2018, it has grown to eight schools with numerous new degree programs both at the undergraduate and postgraduate levels. Additionally, there are different centers shooting out continually within the university mostly running non-degree programs. The academic and non-academic staff strength stands at 2,196 in the 2011/2012 session. In the 2013/2014 session, the students’ population increased to 20,503, from 149 in 1982 [4], representing an increase of 13,660%. This increase in the population of staff and students, of consequence, also brings about approximate rates of increase in the number of guardians, families, friends, and well-wishers that visit, the constant, unchanging in size land piece that makes up the university campus. Implying the pressure on the parking facilities located within the campus has increased, especially during the periods of special events, such as the university convocation ceremonies, inaugural lectures, conferences, and others. In turn, this pressure on parking infrastructure could impact time conservation, vehicular flow and traffic congestion, and thus mobility. Safety issues such as incidents and accidents, vehicle vandalization and thefts, and increased negative environmental and economic externalities from increased emissions of air polluting and greenhouse

gases, and the use of more energy than expected. On the contrary, IPS that can resolve aspects of I2D communication have the capacity to give the occupancy status of parking facilities, providing an informed decision to drivers for proximate parking facilities, and for on-time routing to next preference on an available parking spot. IPS, thus, help to mitigate negative impacts such as poor time conservation, emissions of pollutants and incessant energy usage and travel costs [2], [5]-[9], especially in quasi-close communities with limited or constant parking facilities.

The objectives of this study, therefore, are to determine the need justification [10] for a L-IPS able to resolve aspects of I2D communication for such a quasi-close community like the FUTA campus, to design simple system architecture, assemble and program electronic devices, and to simulate and model a L-IPS. Thus, the proposed system methodology is presented to show how simple microcontroller, liquid crystal display (LCD), ultrasonic sensors and light emitting diodes (LED) indicators can be integrated to form a L-IPS, which in turn can be used to optimize finding available parking spots within a quasi-close community.

II. A REVIEW OF LITERATURE

Parking systems have been around almost since automobiles were invented, and its development fast-tracked in response to the increasing vehicular volume. Such that with the high rate of vehicle ownership, parking has become a conflicting and confusing situation for a number of people, institutions, shopping centers, bus stations and at airports. There are two primary types of parking systems, the traditional and intelligent parking system [11]. Many systems and technological approaches have been developed to overcome the difficulties faced due to the increase in vehicular volume, and the need for effectiveness and efficiency of the overall transportation system, which include ATMS, advanced vehicle communication system (AVCS), advanced public transportation system (APTS), advanced traveler information system (ATIS) and intelligent transport pricing system (ITPS) [6], [9], [10], [12]-[14].

Several IPS solutions from hardware and devices, and software and algorithm, to social and behavioral change, have been developed, including the hierarchical placement algorithm by Kizilkaya et al. [8] that helps to reach a free parking space easily. Jung et al. [15] have studied the semi-automatic parking systems that detect parking slot markings when drivers designate a seed-point inside the target parking slot with a touchscreen. While Geng and Cassandras [16] solve mixed integer linear program (MILP) for assigning and reserving parking slots for users based on requirements that combine proximity to destination and parking costs. Works on parking space detection using image processing approach to inform users on the status of the car parks have been conducted [17], [18]. Novelty in the use of cloud and Internet of Things (IoT) for the smart parking system has been shown, which increases availability, flexibility and less human interface [19], [20]. Wireless technology could be an integral part of the smart parking system that tends to cover a

metropolis or wider regions, and there have been quite a number of efforts in this regard including the use of Bluetooth technology [21], [22]. Mutiara et al. [23] have developed an intelligent parking prototype using a solar cell. Also, studies including Mehmood et al. [24] and Orrie et al. [25] have considered payment for parking spots services their area of focus, in a bid towards full automation.

The L-IPS falls under an IPS category that functions as parking guidance and information system (PGIS), which uses variable message signs (VMS) and other methods that include phones and radios to provide information to users on parking status or traffic situation. It can be implemented metropolis-wide or restricted within a parking facility [2], [3], [6], [9], [11], [26]. Broadly, IPS falls under ITS categorization known as ATMS [10], [12], [21], [27].

III. MATERIALS AND METHODS

Krejcie and Morgan [28] using (1) show that the sample size could be determined to be representative of any given population. Using (1), a sample size of 138 respondents was selected. And 100% response rate was achieved.

$$s = \frac{X^2 NP(1-P)}{d^2(N-1) + X^2 P(1-P)} \quad (1)$$

s = required sample size; X^2 = the table value of chi-square at 1 d.f. at the desired confidence level $(0.05) = (1.96)^2 = 3.8416$; N = the population size (20,503); P = population proportion (0.1); d = degree of accuracy expressed as a proportion (0.05).

A structured questionnaire on the difficulty of finding parking spots on the recommended facility and ease of finding spots on the preferred facility was administered on the FUTA campus to staff and students. As well as familiarity with IPS, perceptions on the IPS' capacity in managing vehicular flow to and out of the parking zone were posed to the respondents. The results of this survey are discussed in Section IV B.

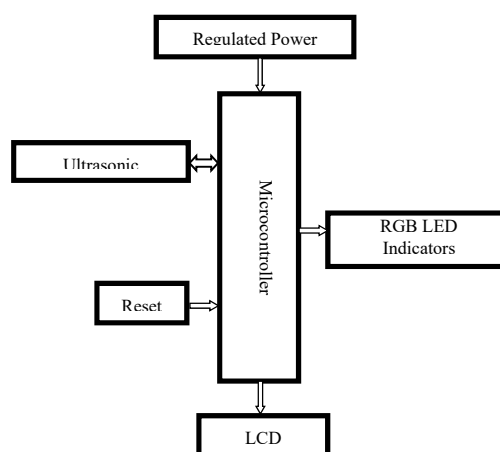

Fig. 1 L-IPS Block Diagram

A. The L-IPS Blocks

The main hardware blocks for this experimental L-IPS are composed of an Arduino Nano microcontroller, I2C chip LCD screen, ultrasonic sensors, jumper wires, 5V output power

supply, and red, green, blue (RGB) LED indicators as shown in Fig. 1.

1. Arduino Nano Microcontroller

An Arduino Nano V3 (see Fig. 2) was used. This is a breadboard-friendly microcontroller compatible with ATmega328. It, however, lacks a DC power jack, so it works with a Mini-USB power link. It receives commands, processes those and sends back the commands to the respective components of the prototype.

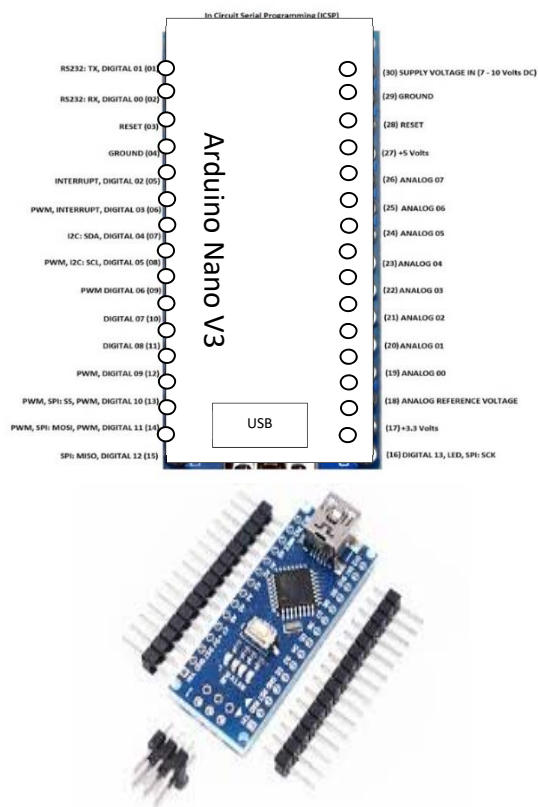

Fig. 2 Arduino Nano (pin description)

2. Arduino Ultrasonic Range Detection Sensors

Sensors are selected based on different factors that include cost, reliability, size, robustness, and adaptation to environmental vulnerability [7], [9]. The Arduino ultrasonic range obstacle detection sensor shown in Fig. 3 was used for this L-IPS. It is an integrated circuit (IC) that transmits ultrasound pulses of about 40 kHz to objects and waits to listen to the reflected pulse calculating the time taken in microseconds. Ultrasonic sensors are considered non-intrusive sensors because they require simpler installation when compared to intrusive sensors like magnetometers, pneumatic road tubes, inductive loops detectors, weigh-in-motion (WIM) sensors or piezoelectric sensors, which require digging and tunneling before installation [2], [7], [29]. Other sensors capable of being used for IPS are active infrared sensors, passive infrared sensors, radio frequency identification (RFID), microwave radar, acoustic sensors, and video image processors [16], [20].

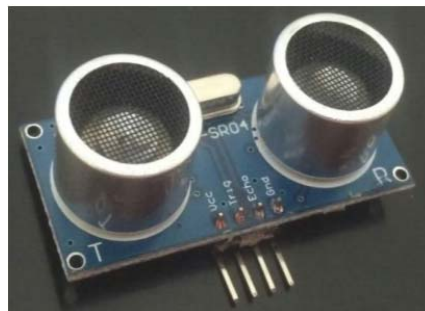

Fig. 3 Arduino Ultrasonic Range Detection Sensor

3. Jumper Wires

Wires (see Fig. 4) are cylindrical, flexible strands of metal used to bear loads of electrical and telecommunication signals.



Fig. 4 Jumper Wires

TABLE I
 SIGNALING AND WIRE CODING FOR L-IPS

Pin	Code	Signal	Nano
1	Green	VCC	VCC
2	Purple	SCL	A4
3	Blue	SDA	A5
4	Yellow	GND	BND

4. I2C Chip Liquid Crystal Display

The liquid crystal display used is a serial LCD 16X2 module with I2C interface, as shown in Fig. 5, able to display 16x2 characters on two lines, white characters on a blue background. Usually, Arduino-LCD projects will run out of pin resources easily. However, this I2C 16x2 Arduino-LCD screen uses I2C communication interface, meaning it only needs four pins for the display: VCC, GND, SDA, and SCL. The VCC, Vbus or V+ (voltage connector to the collector terminal) pin carries a 5-volt signal that provides up to 500 milliamps of power for connected USB devices. The ground (GND) pin provides a neutral 'ground' connection, providing a place for the VCC connection to flow back, completing the circuit. In devices with a large quantity of power, the GND prevents electric shock. In low-voltage USB connections like the one used in this experiment, it only completes the circuits, but also can reduce electromagnetic interference. The SDA (data line) and SCL (clock line) complete the pin connections. All connectors are standard XH2.54 breadboard type. The signaling and wire coding used for this prototype are shown in Table I.

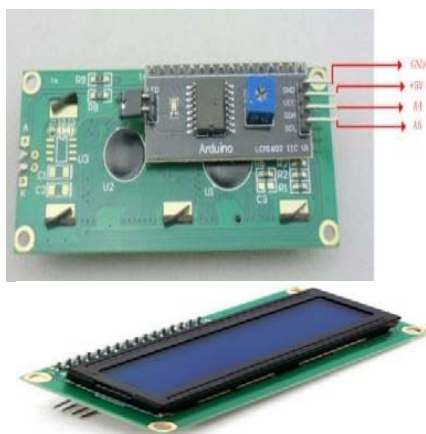

Fig. 5 I2C LCD Screens

5. LED

The RGB LED, usually in one module as shown in Fig. 6, was used. Containing four leads; the common 'ground' is placed on the longest lead, and the other leads control red, green and blue LEDs. The output LED color is controlled based on the voltage written to the different control pins. For this prototype, two of the LEDs, the green and red, are engaged. It is green when the parking spot(s) are available to be occupied, while red shows up when the parking spot(s) are already occupied.

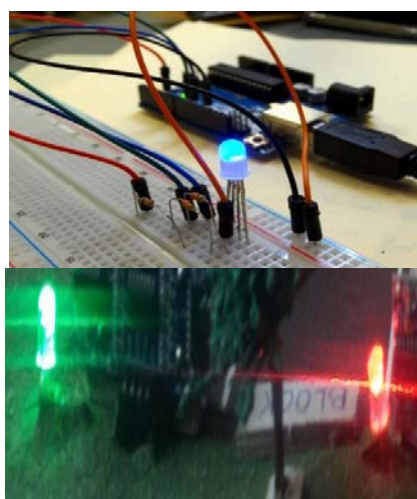

Fig. 6 RGB LED

6. Regulated Power Supply

The system's power supply using a USB jack from a power bank has an output of 5V, as shown in Fig. 7. This is a regulated power from the 230 V AC source as shown in Fig. 8

[30]. Hence, a DC source with 5V output can replace it.



Fig. 7 5V Output Power Source

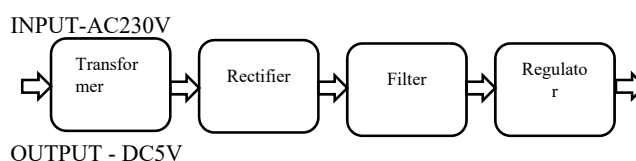

Fig. 8 A Regulated Power Source

B. Arduino Software IDE

A programming language is needed to devise a logic that can make the Arduino board understand the requirements asked of it. With its own code editor, Arduino accepts C and C++ languages. Additional support for Java is also provided by the use of modules that create a virtual runtime environment (RTE) for the hardware to run. Thus, the ultrasonic sensor needs to be programmed in order to function. Its coding is done in the Arduino integrated development environment [31], which employs its features of interrupts, pulses, time-outs, and signals.

C. L-IPS Design and Testing

The design of this L-IPS experiment started with the observation of a typical FUTA campus parking facility; the one situated at the school of management technology (SMAT) building, which is opposite the school of postgraduate studies (SPGS). The facility could accommodate up to 20 cars well parked. Fig. 10 shows a layout of the 4-spot version of this SMAT facility. Four spots were considered for the four intended ultrasonic sensors. The L-IPS circuitry design was done using Proteus software and its schematic diagram is shown in Fig. 10.

The pilot coupling and testing of the electronic devices used were conducted on a breadboard and used Arduino Uno microcontroller and two ultrasonic sensors. The images in Fig. 12 show both scenarios; the full slots availability of two green LED indicators, and when one slot is engaged in red LED indicator, the other slot is available in green.

The coupling and testing made with Arduino Nano microcontroller and four ultrasonic sensors are shown in Fig. 13. The first image shows full four slots availability in green, while for the other, we have two slots engaged in red and two available in green.

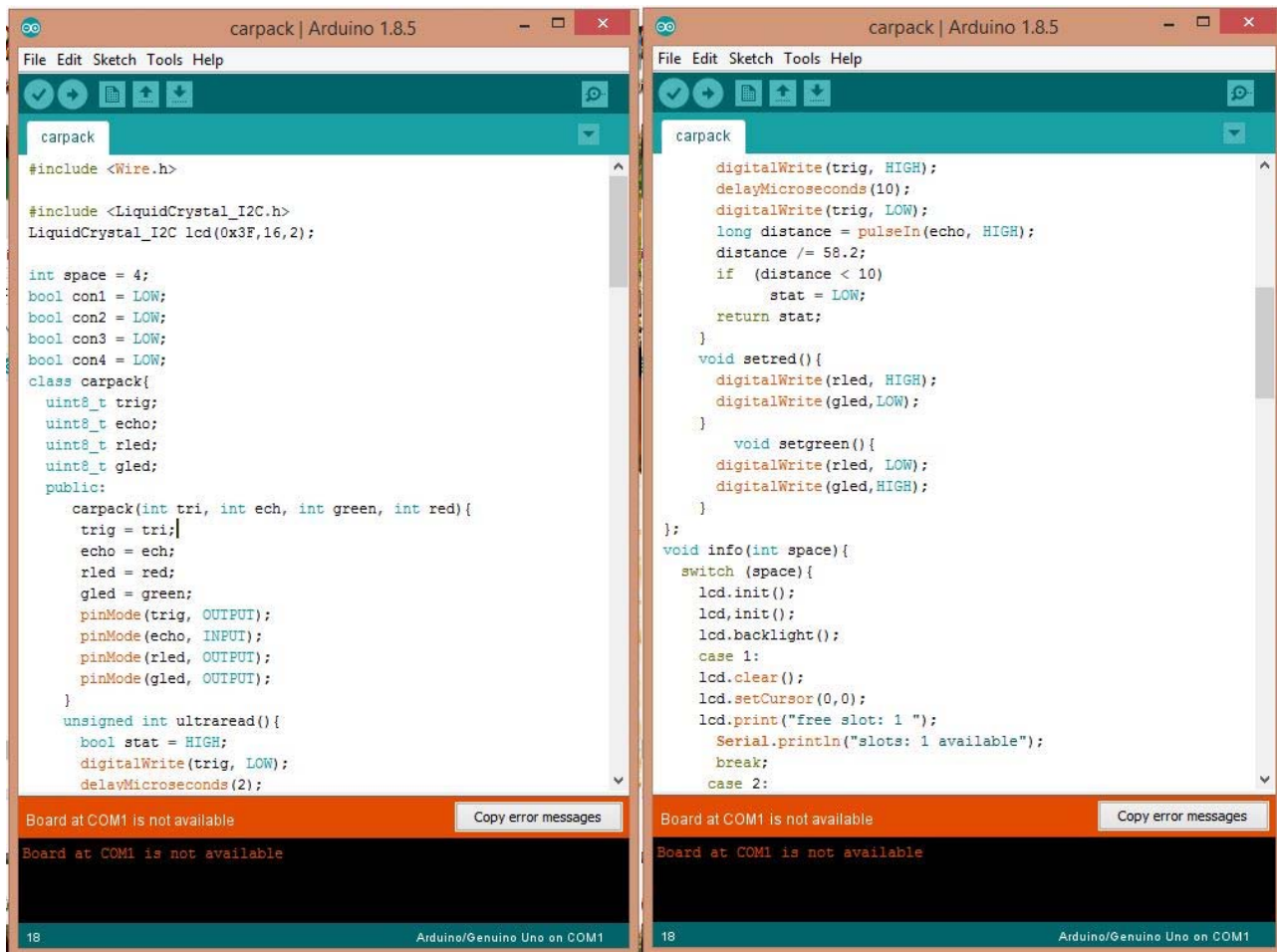

Fig. 9 Arduino coding interface

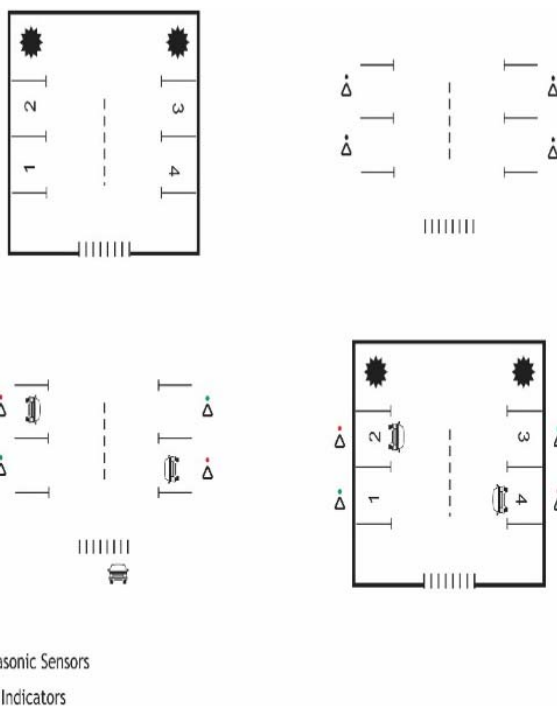

Fig. 10 4-Spot Parking Facility Layout

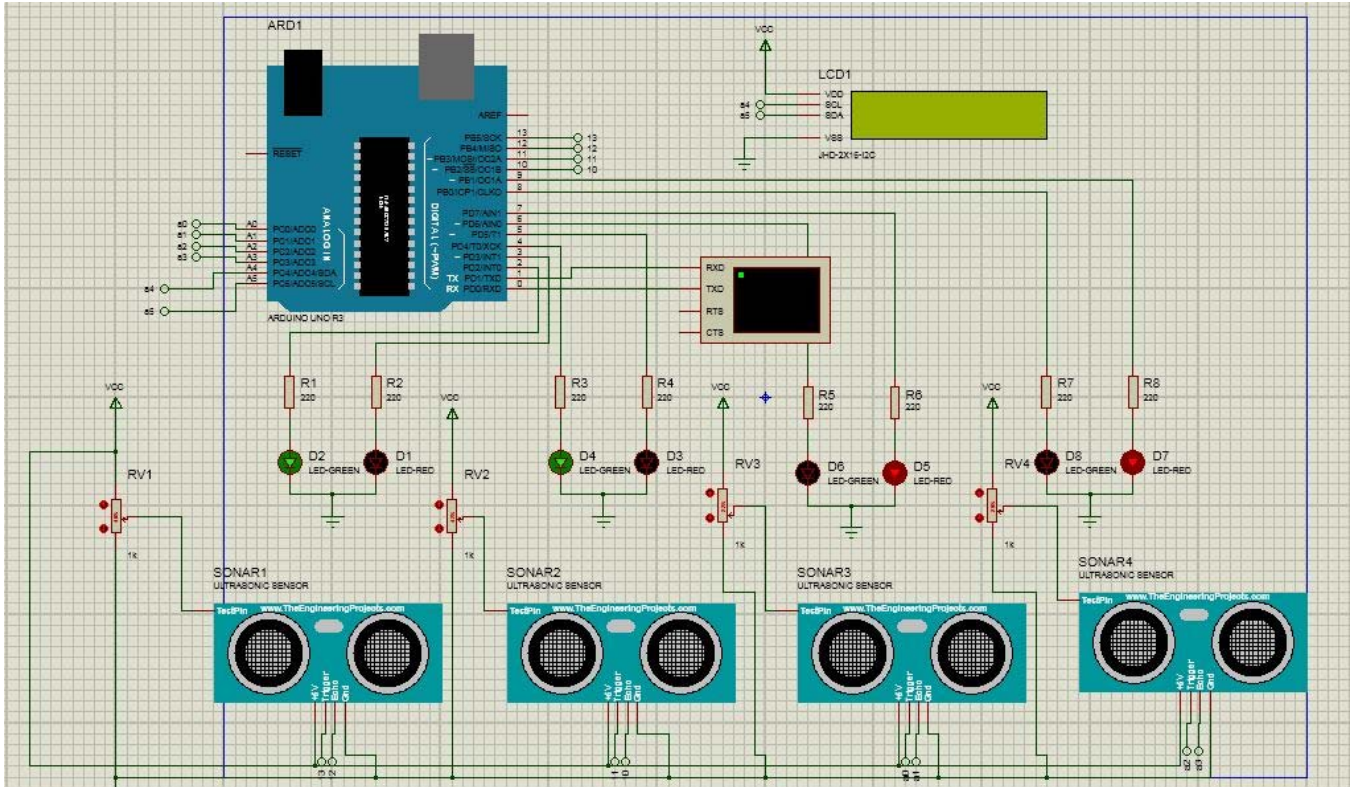

Fig. 11 Circuitry Schematic Diagram using Proteus

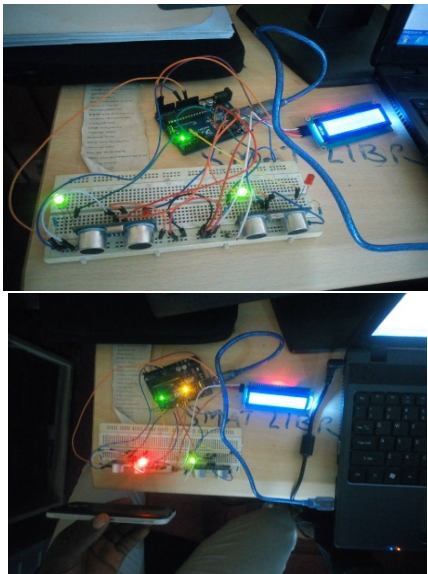

Fig. 12 L-IPS Testing with Arduino Uno and 2 ultrasonic sensors

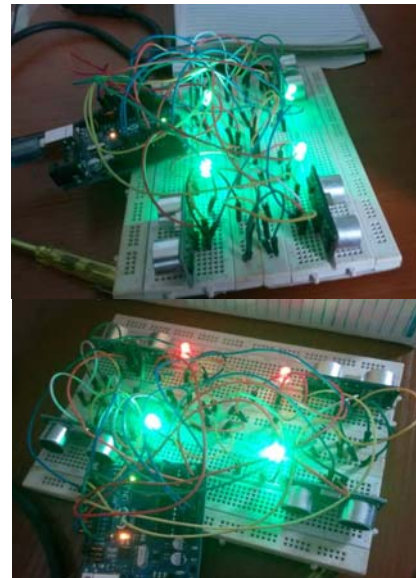

Fig. 13 L-IPS Testing with Arduino Nano and 4 ultrasonic sensors

IV. RESULTS AND DISCUSSION

The workings of the designed L-IPS are discussed in subsection 4.1. The outcome of the questionnaire on the need for IPS, administered to the FUTA campus quasi-close community, justifies the need for such a facility, and its result is discussed under subsection B.

A. Workings of the L-IPS

The L-IPS was designed such that the status of parking spots and the number of vacant parking slots can be known from the entrance of a parking zone of the quasi-close community or directly at the parking facility, hence, the term “localized”. This is achieved with the LCD component, which could be installed at any convenient location within the community. Here, we advise to have it installed at the main entrance or gatehouse of the community or at the entrance to

the parking facility. The occupancy status of each parking slot is detected using ultrasonic sensor [17], [32] placed on every parking slot and transmitted to the LCD, also it is visually shown by the color of the adjoining LED indicators: Green for available and red for occupied.

Fig. 14 shows the operational flowchart of the L-IPS. A user approaches the quasi-close community entrance or a parking facility where the LCD showing the VMS is installed, with the occupancy status of the facility displayed on the screen. A facility user proceeds to parking their vehicle on the proximate slot with green LED indicator if there are free slots available as displayed on the LCD screen; otherwise, they proceed to a next preference parking facility.

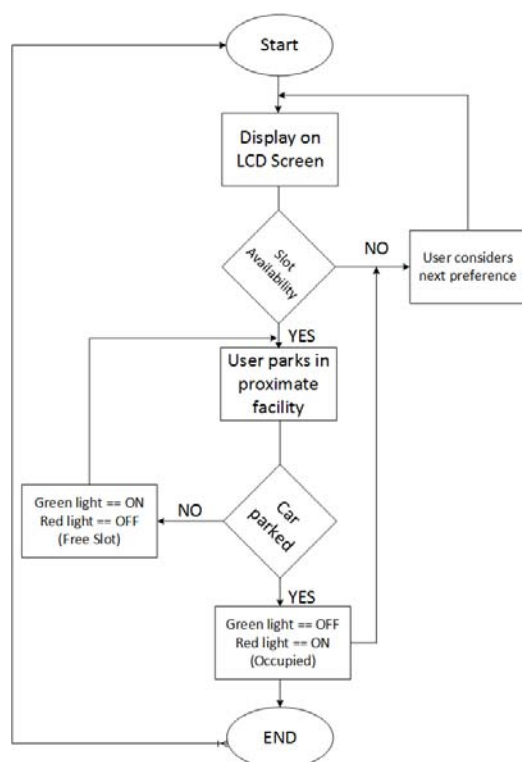

Fig. 14 L-IPS Flowchart

The overview of the model L-IPS is shown in Fig. 15. It shows the parking facility model with mimicked road materials, complete with aesthetics of lawn and trees encircling intended to reflect environmental sustainability. Equipped with ultrasonic sensors, LED indicators, and of course, the LCD VMS screen installed overhead for easy viewing by the facility users.

A working L-IPS is shown in Figs. 16-19. Three vehicles approached the facility gaining information on its occupancy status, and with full parking spot availability for a capacity of four vehicles, it indicates to the three approaching vehicles that they can proceed to park in any proximate slots, 1, 2, 3 or 4. Fig. 16 shows the smallest vehicle had an edge to the facility and proceeded accordingly to a spot of its choice.

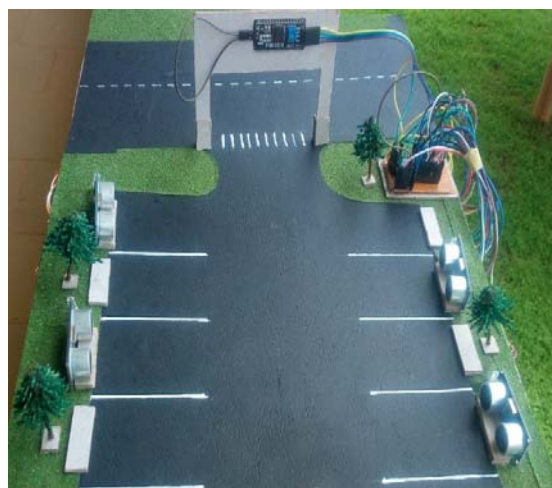

Fig. 15 L-IPS Prototype



Fig. 16 L-IPS Working Prototype with Full (4) Parking Spots Availability (4-Green LED indicators)

The smallest vehicle had entered the facility parking on slot 3 as shown in Fig. 17. The LED indicator on this slot now changes from its earlier green color to red, implying the spot is now engaged, and not available for any other user until the current user vacates the spot. The LCD VMS screen shows this status, indicating three free slots and one engaged. Here also, the yellow car was gaining entrance into the facility next to the smallest occupying coupe.

Next, the yellow car proceeded to park in a slot, which is slot 2 that then indicated the engaged red LED, as shown in Fig. 18. The bigger red car seeing from the LCD VMS screen that there are still two free slots available proceeded to enter the facility.

As shown in Fig. 19, the big red car had moved in to park on slot 2, implying the yellow car switched parking bays from slot 2 to slot 1. All three cars are now conveniently parked in the facility.



Fig. 17 L-IPS Working Prototype with Spot 3 in-use (1-Red LED); Spots 1, 2 and 4 available (3-Green LED)



Fig. 18 L-IPS Working Prototype with Spots 2 and 3 in-use (2-Red LED); Spots 1 and 4 available (2-Green LED)



Fig. 19 L-IPS Working Prototype with Spots 1, 2 and 3 in-use (3-Red LED); Spot 4 available (1-Green LED)

B. Needs Justifications for L-IPS

The Likert data-type [33] result of the survey carried out on the needs considerations [10] for IPS on the FUTA quasi-close community, as shown in Table II, is hereby discussed. The result, on a scale of 1- extremely difficult, 2- difficult, 3- easy, and 4- very easy, is (2.37/4) for the measure of ease in finding a preferred parking spot indicating that the respondents generally find it 'difficult' to find parking spots in the

traditional parking facility. While on a scale of 1- always, 2- often, 3- rarely, and 4- not, the respondents 'rarely' (2.67/4) find it difficult to find a spot in a recommended facility using the traditional parking method. On the familiarity with IPS, the result shows that the respondents are barely familiar (1.95/4) with the solution, but foresee high value (3.20/5) in its use for helping resolve parking difficulties on the campus.

TABLE II
TRADITIONAL PARKING AND PERCEPTIONS TO IPS

Question Point	W. M.	S.D.
Ease of finding a spot to park in a preferred facility	2.37	0.705
The difficulty of finding a spot to park in a recommended facility	2.67	1.035
Familiarity with IPS	1.95	0.813
Value perception of IPS for this quasi-close community	3.20	1.219

The Chi-Square statistic test of the relationship between positional characteristics of the respondents and the difficulty of finding a spot to park in a facility shows that ($p = 0.009$) at $\alpha = 0.05$. Considering the highest percentages, the academic staff do not (39.6%) have difficulty finding a parking spot in a recommended facility, which can be attributed to the fact that most academic staff have designated spots with the leadership cadre having spots with labels to their positions, which are rarely occupied by another. This is reflecting that this quasi-close community used as the study subject for this research is primarily an academic community, implying that preferential allotments of parking spots are given to academic staff members by the University management. The non-academic staff does not have the same magnitude of preference, thus as expected, the results show that they often (37.8%) have difficulty finding parking spots for their vehicles. It is even worse for the students considering that they often (32.5%) have difficulty with parking at recommended spots, as there is no special preference is ascribed to this group of users.

Further, on a Chi-Square statistic examination between characteristics of respondents and familiarity with IPS, the results show significance ($p = 0.030$) at $\alpha = 0.05$. Revealing that the academic staff, on a scale of 1- not familiar, 2- familiar, 3- very familiar, and 4- extremely familiar, show a higher level of familiarity (very familiar); the students' level of familiarity is next (familiar) and the non-academic staff unarguably with a lower level of technological-awareness are not familiar with IPS.

The logical next step was to test the correlation between ease of finding a spot to park in a preferred facility and the value perception of IPS for this quasi-close community. The result shows significance ($p = 0.011$) at $\alpha = 0.05$. Of the 30.8% of respondents who said they find it extremely difficult to find spots to park, they believe that IPS would be 'very' valuable to help resolve the parking issue while 33.3% of those who chose 'difficult' think the IPS may 'just' be valuable. Also, the 44.4% of the respondents that chose 'easy' finding parking spots in a traditional facility, also think IPS may 'just' be valuable. However, 60% of the respondents who chose 'very easy' finding parking spots, as is the case with those who chose 'extremely difficult', think IPS would be 'very'

valuable. These results support the fact that students who find it 'most difficult' to find parking spots are familiar with IPS; and the academic staff who do not have difficulty finding spots to park in a facility are 'very' familiar with IPS. Thus, it can be asserted that the students who mostly find it difficult to find parking spots and the academic staff who do not have difficulty finding parking spots, both believe IPS, if deployed, would be 'very' valuable; basically because of their relatively advanced technological awareness, when compared with the other personnel of the University, the quasi-close community.

Familiarity with the IPS test continued with investigating its value perception for this quasi-close community. The result shows strong p-value (0.002) significance at $\alpha = 0.05$. Those respondents who say that they are not familiar and barely familiar with IPS think that it will be 'just' valuable. While those respondents who say they are very familiar with the IPS technology, on the other hand, think it will be 'very' valuable to help resolve parking issues in the quasi-close community. It is, therefore, extremely refreshing to note that all (100%) of the respondents who are extremely familiar with IPS also have an extremely high value perception in its capability to help resolve parking issues. Such values could include improved traffic flow and travel time conservation, as well as aiding of unimpeded mobility, and thus, contributing less environmental and economic externalities when compared with traditional parking facility.

V. CONCLUSIONS

This paper asserts that the IPS familiarized respondents also know the value of the technological system is very high. It could be concluded, therefore, that the need justification for L-IPS in any quasi-close community is strong and cannot be underestimated, hence it shows this model design is in order. With its implementation, it is believed that the challenge of insufficient parking space and difficulty finding on-time space to berth vehicles within the parking zone would be abated. By extension, the study supports the fact that IPS impacts positively on time conservation, enhancing mobility and traffic flow, and improves safety. IPS also helps to reduce negative environmental and economic externalities, usually in the forms of reducing emissions of pollutants and travel costs, respectively.

VI. FUTURE SCOPE

For a more effective and efficient intelligent parking system, accessing the status of parking slots from anywhere within a metropolis and in real-time, on-demand, could be more appropriate. Hence, this project could be extended to include integrating metropolitan wireless technology, such as using GSM technology with IPS. The IPS services, therefore, could include the possibility to book slots ahead of time. Thus, IPS services could be made accessible through apps on mobile devices.

ACKNOWLEDGMENT

The authors deeply thank the editors and the anonymous

reviewers for their positive critique that greatly helped improved the quality of this paper.

REFERENCES

- [1] Tole, L. (2008). "Changes in the built vs non-built environment in a rapidly urbanizing region: A Case Study of the Greater Toronto Area," *Computers, Environment and Urban Systems*, vol. 32 issue 5, pp. 355-364. ISSN: 0198-7515.
- [2] Idris, M.Y.I., Tamil, E.M., Noor, N.M., Razak, Z. and Fong, K.W. (2009a). "Parking Guidance System Utilizing Wireless Sensor Network and Ultrasonic Sensor," *Information Technology Journal*, vol. 8 issue 2, pp. 138-146. ISSN: 1812-5638.
- [3] Idris, M.Y.I., Leng, Y.Y., Tamil, E.M., Noor, N.M. and Razak, Z. (2009b). "Car Park System: A Review of Smart Parking System and its Technology," *Information Technology Journal*, vol. 8 issue 2, pp. 101-113. ISSN: 1812-5638.
- [4] Department of Transport Management Technology (2015). "Students' Handbook 2010-2015," School of Management Technology, Federal University of Technology, Akure.
- [5] Ahad, A., Khan, Z.R. and Ahmad, S.A. (2016). "Intelligent Parking System," *World Journal of Engineering and Technology*, vol. 4, pp. 160-167.
- [6] Chai, H., Ma, R. and Zhang, H.M. (2018). "Search for parking: A Dynamic Parking and Route Guidance System for Efficient Parking and Traffic Management," *Journal of Intelligent Transportation Systems*, DOI: <https://doi.org/10.1080/15472450.2018.1488218>
- [7] Kianpisheh, A., Mustaffa, N., Limtrairut, P. and Keikhosrokiani, P. (2012). "Smart Parking System Architecture Using Ultrasonic Detector," *International Journal of Software Engineering and its Applications*, vol. 6 issue 3, pp. 51-58.
- [8] Kizilkaya, B., Caglar, M., Al-Turjman, F. and Ever, E. (2018). "An Intelligent Car Park Management System: Hierarchical Placement Algorithm Based on Nearest Location," *Proceedings of 32nd International Conference on Advanced Information Networking and Applications Workshops*, in *IEEE Explore Digital Library*. DOI: <https://doi.org/10.1109/WAINA.2018.00151>
- [9] Paidi, V., Fleyeh, H., Hakansson, J. and Nyberg, R.G. (2018). "Smart Parking Sensors, Technologies, and Applications for open parking lots: a review," *IET Intelligent Transport Systems*, vol. 12 issue 8, pp. 735-741. DOI: <http://dx.doi.org/10.1049/iet-its.2017.0406>
- [10] Faiyetole, A.A. (2019). "A Review of Intelligent Transport System, and its People's Needs Considerations for Traffic Management's Policy Framework in a Developed Country;" In Outay, F., Yasar, A., and Shakshuki, E. Editors, *Global Advancements in Connected and Intelligent Mobility: Emerging Research and Opportunities*. IGI-Global, USA: Pennsylvania.
- [11] Santhosh, G. and Sathish, G.C. (2017). "Frameworks for Parking Systems: A Survey," *Proceedings of Second National Conference on Advances in Computing and Information Technology*, published in *Asia Journal of Engineering and Technology Innovation (AJETI)*, pp. 149-152.
- [12] Amadi, E.C., Ahaiwe, J., Etus, C. and Akpabio, N. (2014). "Deployment of ICT for Effective Transportation System in Nigeria: A Design model of Nigerian System in Nigeria." *International Journal of Science and Research (IJSR)*, vol. 3 issue 11, pp. 24-32.
- [13] Hassoune, K., Dachry, W., Moutaouakkil, F. and Medromi, H. (2016). "Smart Parking Systems: A Survey," *Proceedings of 11th International Conference on Intelligent Systems: Theories and Applications (Sita)*, published by *IEEE Xplore*, pp. 1-6. <https://doi.org/10.1109/SITA.2016.7772297>
- [14] Singh, B., Gupta, A., and Suman, S. (2014). "Framework for Development of Advanced Traveler Information System: A Case Study for Chandigarh City." *Proceedings of International Conference on Transportation Planning and Implementation Methodologies for Developing Countries 2014 (TPMDC-2014)*, Submission Id. 54.
- [15] Jung, H.G., Kim, D.S. Yoon, P.J. and Kim, J. (2006). "Structure Analysis Base Parking Slot Marking Recognition for Semi-Automatic Parking System," in D.Y. Yeung *et al.* (Eds.) *SSPR & SPR, LNCS 4109*, pp. 384-393. Springer-Verlag Berlin Heidelberg.
- [16] Geng, Y. and Cassandras, C.G. (2012). "A New 'Smart Parking' System Infrastructure and Implementation," *Procedia - Social and Behavioral Sciences*, vol. 54, pp. 1278-1287.
- [17] Al-Kharusi, H. and Al-Bahadly, I. (2014). "Intelligent Parking Management System Based on Image Processing," *World Journal of*

- Engineering and Technology, vol. 2, pp. 55-67.
- [18] Yusnita, R. Norbaya, F. and Basharuddin, N. (2012). "Intelligent Parking Space Detection System Based on Image Processing," *International Journal of Innovation, Management and Technology*, vol. 3 issue 3, pp. 232-235.
- [19] Basavaraju, S.R. (2015). "Automatic Smart Parking System using the Internet of Things (IoT)," *International Journal of Scientific and Research Publications*, vol. 5 issue 12, pp. 629-632.
- [20] Gandhi, B.M.K. and Rao, M. K. (2016). "A Prototype for IoT Based Car Parking Management System for Smart Cities," *Indian Journal of Science and Technology*, vol. 9 issue 17, pp. 1-6.
- [21] Singh, H., Anand, C., Kumar, V. and Sharma, A. (2010). "Automated Parking System with Bluetooth Access," *International Journal of Engineering and Computer Science*, vol. 3 issue 5, pp. 5773-5775.
- [22] Yee, H.C. and Rahayu, Y. (2014). "Monitoring Parking Space Availability Via Zigbee Technology," *International Journal of Future Computer and Communication*, vol. 3, issue 6, pp. 377-380.
- [23] Mutiara, G.A., Agung, A.A.G, and Handayani, R. (2017). "MAC Address-Based Smart Parking Prototype using Solar Cell," *ARN Journal of Engineering and Applied Sciences*, vol. 12 issue 4, pp. 1085-1091.
- [24] Mehmood, Z., Haneef, O., Mohammad, N. and Khattak, S. (2018). "Towards a Fully Automated Car Parking System," *IET Intelligent Transport Systems*, <http://dx.doi.org/10.1049/iet-its.2018.5021>.
- [25] Orrie, O., Silva, B., and Hancke, G.. (2015). "A Wireless Smart Parking System," *Proceedings of 41st Annual Conference of the IEEE Industrial Electronics Society, IECON*, published in IEEE Xplore, pp. 004110-004114.
- [26] Sakai, A.K., Mizuno, T., Sugimoto, and Okuda, T. (1995). "Parking Guidance and Information System," *Proceedings of Vehicle Navigations and Information System Conference in Conjunction with the Pacific Rim TransTech Conference, 6th International VNIS. A Ride into the Future, July 30-August 2, IEEE Explore*, pp. 478-485.
- [27] Bertini, R. and El-Geneidy, A. (2002). "Advanced Traffic Management System Data. In D. Gillen & D. Levinson (Eds.), *Assessing the Benefits and Costs of ITS. Transportation Research, Economics and Policy*, (vol 10, pp. 287-314). Springer, Boston, MA.
- [28] Krejcie, R.V. and Morgan, D.W. (1970). "Determining Sample Size for Research Activities," *Educational and Psychological Measurement*, vol. 30, pp. 607-610.
- [29] Scheeling, J. (2002). "Car Park Monitoring System," University of Queensland.
- [30] Rao, Y.R. (2017). "Automatic Smart Parking System using the Internet of Things (IoT)," *International Journal of Engineering Technology Science and Research*, vol. 4 issue 5, pp. 225-228. ISSN: 2394-3386.
- [31] Arduino IDE (2018). "Arduino Software IDE on Windows PC," from [Arduino.cc: https://www.arduino.cc/en/Guide/Windows](https://www.arduino.cc/en/Guide/Windows), accessed 08 August 2018.
- [32] Mimbela, L.E.Y. and Klein, L.A. (2000). "A Summary of Vehicle Detection and Surveillance Technologies used in Intelligent Transport System," Southwest Technology Development Institute (SWTDI) at New Mexico State University.
- [33] Faiyetole, A.A. (2018). "Potentialities of Space-Based Systems for Monitoring Climate Policies and Mitigation of Climate Process Drivers," *Astropolitics*, vol. 16 issue 1, pp. 28-48.