

A Hygrothermal Analysis and Structural Performance of Wood-Frame Wall Systems with Low-Permeance Exterior Insulation

Marko Spasojevic, Ying Hei Chui, Yuxiang Chen

Abstract—Increasing the level of exterior insulation in residential buildings is a popular way for improving the thermal characteristic of building enclosure and reducing heat loss. However, the layout and properties of materials composing the wall have a great effect on moisture accumulation within the wall cavity, long-term durability of a wall as well as the structural performance. A one-dimensional hygrothermal modeling has been performed to investigate moisture condensation risks and the drying capacity of standard 2×4 and 2×6 light wood-frame wall assemblies including exterior low-permeance extruded polystyrene (XPS) insulation. The analysis considered two different wall configurations whereby the rigid insulation board was placed either between Oriented Strand Board (OSB) sheathing and the stud or outboard to the structural sheathing. The thickness of the insulation varied between 0 mm and 50 mm and the analysis has been conducted for eight different locations in Canada, covering climate zone 4 through zone 8. Results show that the wall configuration with low-permeance insulation inserted between the stud and OSB sheathing accumulates more moisture within the stud cavity, compared to the assembly with the same insulation placed exterior to the sheathing. On the other hand, OSB moisture contents of the latter configuration were markedly higher. Consequently, the analysis of hygrothermal performance investigated and compared moisture accumulation in both the OSB and stud cavity. To investigate the structural performance of the wall and the effect of soft insulation layer inserted between the sheathing and framing, forty nail connection specimens were tested. Results have shown that both the connection strength and stiffness experience a significant reduction as the insulation thickness increases. These results will be compared with results from a full-scale shear wall tests in order to investigate if the capacity of shear walls with insulated sheathing would experience a similar reduction in structural capacities.

Keywords—Hygrothermal analysis, insulated sheathing, moisture performance, nail joints, wood shear wall.

I. INTRODUCTION

RISING demands of energy codes and building standards in Canada have led to the increased insulation levels in many new and existing residential buildings. Adding insulation exterior to the wall cavity is a common practice for improving thermal resistance of a wall; however, putting more insulation sometimes may lead to increased problems in managing moisture.

The position of building materials within the wall assembly, their hygrothermal properties as well as the indoor and

outdoor climate conditions have a great impact on moisture accumulation, drying potential and a durability of the wall. In the assembly, a rigid foam insulation may be installed either exterior to the wood structural panel sheathing that has been nailed to wall studs or inserted between the sheathing and framing. The benefit of the first configuration would be a higher lateral resistance and better structural performance under loads caused by winds and earthquakes. On the other hand, low-permeance rigid insulation placed over wood-based structural sheathing may have a negative effect on the drying potential of the wall and may cause high moisture contents of the sheathing during the heating season. Additionally, the first configuration using a thicker layer of exterior insulation may experience difficulties in attaching some cladding materials to the wall. On the other hand, the later configuration would allow bonding of different wall components (e.g., air barrier, rigid insulation and the sheathing) into one panel which could significantly speed up the process of wall construction. However, this configuration experiences a reduction in racking resistance of the shear wall as the thickness of insulation increases.

During the heating season, moisture from the warmer indoor air migrates into and through the building assembly by two processes: vapor diffusion and air convection. Vapor diffusion can be effectively controlled by placing a vapor retarder at the warm side of the cavity, for instance, between the interior gypsum board and the insulation [1]. Air convection mostly occurs at joints, holes, and cracks, and even small air fluxes can carry significantly larger volumes of water vapor compared to vapor diffusion [2].

The National Building Code of Canada (NBCC) prescribes requirements on heat transfer, air leakage and moisture condensation control for building components and assemblies separating indoor conditioned space from exterior environment [3]. Part 9 of Division B of the NBCC gives prescriptive requirements and applies to buildings up to three stories high and not exceeding a building area of 600 m², whereas Part 5 defines performance-based requirements that apply to all other buildings.

Article 9.25.5.2. of the 2014 NBCC defines allowable positions of low-permeance materials and specifies the minimum required ratio of outboard to inboard thermal resistance when a low air- and vapor-permeance material is located within the assembly. These prescriptive requirements are meant to prevent excessive moisture accumulation caused by the exfiltrating air. The design values given in Table

Marko Spasojevic is MSc student, Ying Hei Chui is Professor, and Yuxiang Chen is Assistant Professor at the Department of Civil and Environmental Engineering, University of Alberta, Edmonton, Canada (e-mail: mspasoje@ualberta.ca, yhc@ualberta.ca, yuxiang.chen@ualberta.ca).

9.25.5.2. of the 2014 NBCC are based on the assumption that an indoor relative humidity would not exceed 35% in colder climates and 60% in mild climates [4]-[6]. Also, in developing these design values, the assembly had an air leakage value of not more than 0.1 L/(s·m²) at air pressure difference of 75 Pa, and a 60 ng/(m²·s·Pa) vapor barrier on interior side of the cavity. For cases where the intended use of the interior space would result in higher moisture generation and higher relative humidity, the assembly shall be designed according to Part 5. Part 5 of the NBCC sets an air leakage limit of 0.02 L/(s·m²) at 75 Pa for materials intended to provide the principal resistance to air leakage in order to minimize the moisture accumulation in a wall assembly.

This paper presents research that compared two different wall assemblies constructed with low-permeance XPS insulation placed either between OSB sheathing and the stud or outboard to the structural sheathing. Walls were exposed to different exterior conditions in Canada and the wintertime interior relative humidity varied between 35% and 55% with air exfiltration varying between 0.02 L/(s·m²) and 0.1 L/(s·m²) at 75 Pa. In investigating the moisture accumulation, all wall assemblies were simulated using a one-dimensional hygrothermal modelling software WUFI[®] Pro 6.2 [7].

To investigate how the structural performance of the wall is compromised when a layer of insulation is inserted between the sheathing and framing, 40 nail connection specimens were tested. The aim of this study was to provide information on how the structural and hygrothermal performance of a wall are affected by placing rigid insulation at different location within the wall.

II. HYGROTHERMAL MODELING

A. Wall Configurations and Materials

This study investigated and compared the hygrothermal performance of two different wood-frame wall assemblies, illustrated in Fig. 1. This figure also shows the location of the plane that divides the outboard from inboard insulation as it is suggested in the NBCC [3].

The first wall configuration (Assembly 1) included a layer of extruder polystyrene insulation (XPS) placed outboard to the structural sheathing, whereas that same insulation was inserted between the sheathing and framing in the second wall assembly (Assembly 2). Both assemblies were simulated as having been constructed with wood framing, either 38 mm × 89 mm (nominal 2×4 in.) or 38 mm × 140 mm (nominal 2×6 in.). Wood framing, however, was not modeled as the simulation was one-dimensional and included a section through the insulated cavity rather than the framing. Both wall assemblies were clad with 19-mm stucco siding and included a spunbonded polyolefin weather-resistive barrier (WRB) behind it.

The thickness of low-permeance XPS insulation varied between 0 mm and 50 mm and exterior structural sheathing in both wall configurations was a 12.5 mm OSB. The stud cavity was filled with fiber glass batt insulation and on its interior side there was a vapor barrier that met the NBCC 2015

9.25.4.2 minimum requirement for vapor permeance of 60 ng/(m²·s·Pa). Also, all assemblies included 12.5 mm thick interior gypsum board. Table I describes the labels of these two assemblies having different thickness of exterior insulation. The difference between the wall W-0 and W-X was that the OSB sheathing in the wall W-X did not have moisture sorption characteristics in order to allow the moisture to stay in the cavity.

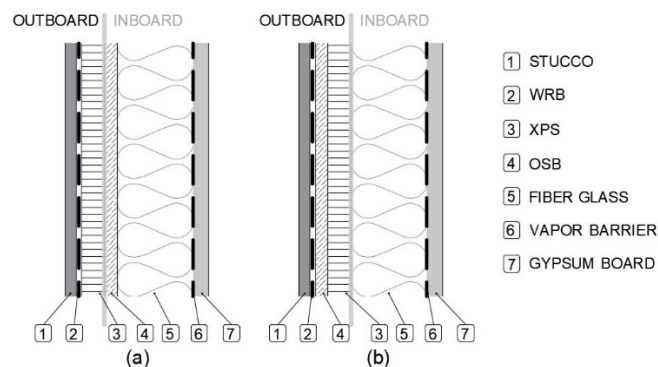

Fig. 1 Assembly 1 (a) and Assembly 2 (b)

TABLE I
WALL LABELS

Exterior Insulation	Assembly 1	Assembly 2
No insulation	W-0	W-X
12.7 mm	W-1	W-I
25.4 mm	W-2	W-II
38.1 mm	W-3	W-III
50.8 mm	W-4	W-IV

The hygrothermal properties of all materials used in simulations were taken from the WUFI database (Generic North America Database).

B. Exterior Climate

The hygrothermal simulation was performed for eight different locations in Canada, covering climate zone 4 through zone 8 (Table II).

TABLE II
LOCATIONS AND CLIMATE ZONES

Location	HDD	Climate Zone
Vancouver	2900	4
Toronto	3650	5
Ottawa	4600	6
St. John's	4800	6
Edmonton	5400	7A
Winnipeg	5900	7A
Fort McMurray	6550	7B
Yellowknife	8500	8

Exterior boundary conditions included outdoor temperature and relative humidity, whereas solar radiation and the effect of rain were omitted. Wind speed and wind direction were accounted for in determining a moisture source due to air exfiltration. Twenty years of hourly weather data were obtained from Environment Canada and the coldest winter

was identified for each location. The hygrothermal analysis considered two years of weather data, a year that preceded the coldest winter and the following year. After these two years the weather cycle repeated.

C. Indoor Environment

Interior temperature was derived based on ASHRAE 160-2016 Standard provisions for heating and air-conditioning where the indoor temperature was set at 21.1°C when the 24-hour average outdoor temperature was below 18.3°C and 2.8°C above the 24-hour running average of the outdoor temperature when it was above 18.3°C. The indoor temperature had a maximum of 23.9°C [8].

Health Canada recommends that indoor relative humidity be kept between 30% and 55% in winter. Low relative humidity can cause skin allergies and respiratory infections, whereas higher humidity levels increase the spread of viruses, bacteria and mold [9].

The indoor relative humidity was calculated based on a moisture balance equation between the indoor and outdoor air [10]. To investigate the effect of indoor relative humidity on the moisture performance of light wood-frame walls with insulated sheathing, the analysis covered three different levels of average wintertime interior relative humidity for each location. The governing parameters for the moisture balance equation were:

- Room volume: 195 m³
- Moisture generation: 6 L/day
- Absorption/desorption: alpha=0.6; beta=0.4

The rate of ventilation (ACH) was varied for each location such that it yielded the wintertime average relative humidity values of 35%, 45% and 55%, respectively.

D. Air Exfiltration

To investigate the effect of air exfiltration when the intended use of the interior space would result in relative humidities between 35% and 55%, three different air leakage rates were simulated for each location. The lower limit was chosen to comply with the NBCC Part 5 allowable maximum air leakage of 0.02 L/(s·m²) and the upper air leakage limit was set at 0.1 L/(s·m²), the NBCC Part 9 limit. Additionally, an air leakage rate of 0.05 L/(s·m²) was chosen as an intermediate value. All air leakage rates were assumed to have been measured at an air pressure difference of 75 Pa. WUFI[®] Pro 6.2 models the deposition of water vapor carried by exfiltrating air by introducing a moisture source at the location where it is most likely for this moisture to accumulate (i.e. OSB sheathing in Assembly 1 and at the XPS-Fiberglass interface in Assembly 2), neglecting the thermal effects of exfiltrating air and water vapor phase change. The strength of the moisture source was based on the air pressure difference across the wall assembly, which was a function of wind velocity and stack effect, whereas the influence of mechanical ventilation on air pressure differential was neglected. For each location considered in this study, hourly weather data were analyzed and the wall orientation that yielded the highest average air exfiltration rate was selected. This study

considered a three-story building and the stack pressure was calculated at the top of the third story as that location was subjected to the highest exfiltration rate, according to (4). The air leakage rate was pre-calculated using hourly weather data for each geographic location and a transient moisture source was introduced in WUFI by the following equations:

$$m = Q \times (c_i - c_{sat,T}) \quad (1)$$

$$Q = \alpha \times \Delta P_{tot}^n \quad (2)$$

$$\Delta P_{tot} = \Delta P_{wind} + \Delta P_{stack} + \Delta P_{vent} \quad (3)$$

$$\Delta P_{stack} = \rho \times \left(\frac{T_o - T_i}{T_i} \right) \times g \times \frac{H}{2} \quad (4)$$

$$\Delta P_{wind} = \frac{1}{2} \times C_{wp} \times \rho \times v^2 \quad (5)$$

Table III lists all the symbols used in these equations.

TABLE III
SYMBOLS AND UNITS FOR CALCULATING AIR EXFILTRATION

Symbol	Quantity	Unit
m	moisture source	kg/(s·m ²)
Q	air flow rate	m ³ /(s·m ²)
c _i	indoor water vapor concentration	kg/m ³
c _{sat,T}	water vapor concentration at saturation at the deposition site	kg/m ³
α	air flow coefficient – depends on the airtightness of the wall i.e. α=4.87×10 ⁻⁶ for assigned air leakage rate of 0.1 L/(s·m ²) at 75 Pa	m ³ /(s·m ² ·Pa ^{0.7})
n	0.7 [11]-[16]	-
ΔP _{tot}	total air pressure difference	Pa
ΔP _{wind}	pressure differential due to wind	Pa
ΔP _{stack}	pressure differential due to stack effect	Pa
ρ	density of air	kg/m ³
T _o	outdoor temperature	°C
T _i	indoor temperature	°C
g	gravitational acceleration	m/s ²
H	7.5 m, building height	m
C _{wp}	surface pressure coefficient of wind [16]	-
v	wind velocity	m/s

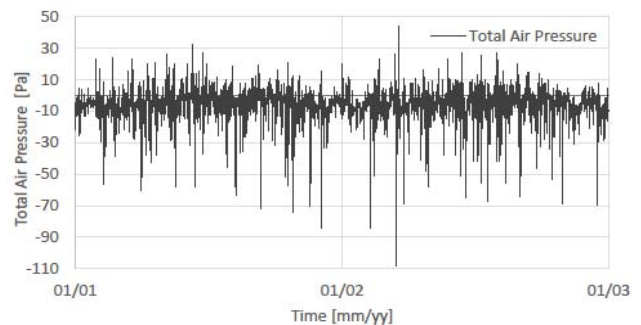

Fig. 2 Total Air Pressure (Edmonton)

Fig. 2 shows hourly air pressure difference calculated in accordance with (3) for Edmonton climate. Additionally, Fig. 3 illustrates the transient moisture source due to air exfiltration for the wall W-3, calculated by using (1).

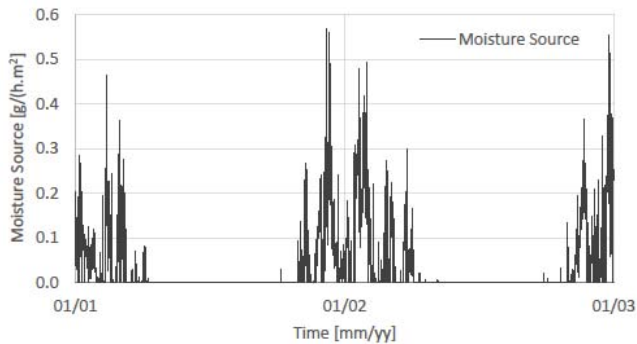

Fig. 3 Moisture source (Assembly 1; W-3; $RH_{int}=35\%$; Air Leakage rate $0.1 \text{ L}/(\text{s}\cdot\text{m}^2)$ at 75 Pa)

E. Initial Conditions and Calculation Period

The initial temperature in each component was set to 0°C , since all simulations started on the 1st of January. Each material composing the wall was assigned a typical build-in moisture content from the WUFI database, except for OSB sheathing which moisture content was set to 17%. Simulations were run for a period of four years using 1-h time step.

F. Acceptable Performance

The analysis investigated the total moisture content changes per unit area of a wall, moisture content changes in OSB sheathing and the potential for mold growth on different surfaces of wall components. The traditional guideline for protection of wood and wood products from decay has been to keep the moisture content below 20% [17]. For that reason, the first performance criterion was that the OSB moisture content did not exceed 20% at any time and that the moisture content in any wall component was not increasing from year to year.

TABLE IV
MOLD INDEX (M) DESCRIPTION [18]

Mold Index (M)	Description of Growth Rate
1	No growth
2	Small amounts of mold on surface (microscope), initial stages of local growth
3	Visual findings of mold on surface, < 10% coverage, or < 50% coverage of mold (microscope)
4	Visual findings of mold on surface, 10%–50% coverage, or > 50% coverage of mold (microscope)
5	Plenty of growth on surface, > 50% coverage (visual)
6	Heavy and tight growth, coverage about 100%

In order to minimize problems associated with mold growth, the analysis investigated a mold growth potential of different building materials and at different locations within the wall. In Assembly 1, for instance, the most critical location for mold to occur was OSB sheathing, whereas it was XPS-Fiberglass interface in Assembly 2. Reference [18] describes a mold index (M) criteria which was used in assessing the mold growth potential. Each material was assigned a sensitivity category, or more specifically, the sensitivity class for OSB layer was “sensitive” whereas the sensitivity class of fiber glass and XPS insulation was set as “medium resistant”. Other

materials were not considered as it was found that they were not at risk for mold growth. Reference [18] also describes the minimum relative humidity needed for mold growth depending on the material sensitivity class. For instance, for “sensitive” materials, minimum relative humidity required for mold growth is 80%, whereas it is 85% for “medium resistant” materials. Mold growth index levels are described in Table IV. No risk of visual mold growth occurs if $M < 3$ at any location within the wall assembly.

G. Modeling Approach

The analysis covered two different wall assemblies, where the thickness of exterior XPS insulation varied between 0 mm and 50 mm, eight locations in Canada, three different air exfiltration rates and three levels of interior relative humidity. During the analysis only one parameter was altered at a time while all the others were kept unchanged. The simulation was conducted to determine the minimum required ratio of outboard to inboard insulation to control moisture accumulation in the wall and to meet performance requirements. Furthermore, the analysis investigated how the moisture performance of the wall with low-permeance insulation placed outboard to the sheathing compared to the wall with that same insulation inserted between the sheathing and framing.

III. TESTING OF NAIL JOINTS

A. Test Program

According to the Canadian timber design standard, CSA O86-14 [19], the shear resistance of a shear wall can be calculated based on the nailed joint strength as presented in (6):

$$V_r = \frac{N_u}{s} \quad (6)$$

where: V_r [N/mm] - shear strength of shear wall per unit length, N_u [N] - strength of a nail joint, s [mm] - spacing of nails at perimeter of framing members.

To investigate how an insulation layer placed between the sheathing and framing affects the structural performance of a wall, nailed joint specimens with different nail sizes and insulation thickness were tested. Table V presents the nailed joint test program. A total of 40 nail joint specimens, covering eight different combinations of nail size and insulation thickness, were tested.

TABLE V
NUMBER OF NAILED JOINT SPECIMENS TESTED

Insulation thickness	Number of specimens	
	10d nails	16d nails
no insulation	5	5
12.7 mm	5	5
25.4 mm	5	5
38.1 mm	-	5
50.8 mm	-	5

B. Materials and Geometry

Lumber pieces used in this study were cut from 38 mm by 140 mm (nominal 2×6 in.) spruce-pine-fir (SPF) dimension lumber with grade No. 2 or better. Initial moisture content of lumber was $11.5 \pm 1.5\%$ and the studs had an oven-dry density of 444 kg/m^3 with a coefficient of variation of 0.095. OSB was used as a sheathing panel and the thickness of OSB was 15.1 mm. Specimens that included a layer of intermediate insulation were built with XPS foam insulation with thicknesses varying between 12.7 mm and 50.8 mm, at 12.7 mm increments. Nails used in this study were common wire nails with smooth shank and diameters of 3.66 mm and 4.06 mm, for 10d and 16d nails, respectively. Nail length was 76 mm for 10d nails and 89 mm for 16d nails. Fig. 4 illustrates the test setup used for the testing of nail joints. Both wood sections were clamped using steel plates and threaded rods which helped in leveling the specimen and keeping the line of loading to be directly through the center of the specimen.

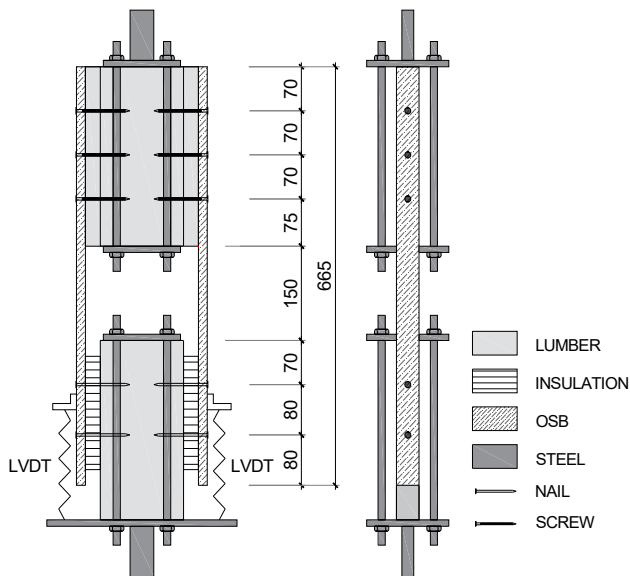

Fig. 4 Front and Side View of Nail Joint Test Setup

C. Test Procedure

All nail joint specimens were subjected to monotonic tensile loading with an applied displacement rate of 2.54 mm/min. Two Linear Variable Differential Transformers (LVDTs) were attached to both sides of the specimen to record the relative displacement between lumber and OSB. The average displacement between the two LVDTs was calculated, and the recorded load from the test frame was divided by 4 to provide load data per nail.

IV. RESULTS AND DISCUSSION

A. Hygrothermal Modeling

Figs. 5- 8 graphically present the simulation results for both wall assemblies, for Edmonton climate. The indoor average wintertime relative humidity was 35% and the air leakage rate was $0.1 \text{ L/(s}\cdot\text{m}^2)$ at 75 Pa. Fig. 5 shows the average moisture

content values for the whole OSB sheathing in Assembly 1. It can be seen that low-permeance insulation placed exterior to the sheathing has a significant effect on OSB moisture content and its drying potential. Putting insufficient amount of low-permeance insulation exterior to the sheathing could cause excessive moisture accumulation in OSB that increases over time (Fig. 5, W-1). On the other hand, when 38 mm of exterior insulation was used (Fig. 5, W-3), OSB moisture content did not exceed the threshold of 20%. For this same wall assembly, Fig. 6 shows that when inadequate ratio of outboard to inboard thermal resistance was used the mold growth index did not converge and went above the acceptable performance limit ($M=3$). The same level of exterior insulation was required to meet both performance criteria for Assembly 1, where the sheathing has been directly nailed to the framing.

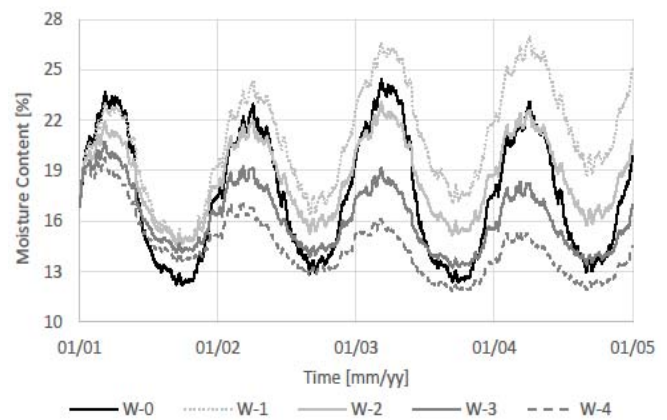

Fig. 5 OSB moisture content (Assembly 1)

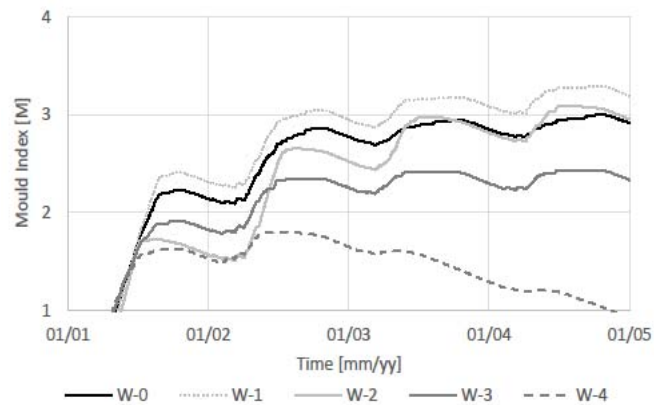

Fig. 6 Mold index in OSB (Assembly 1)

In the wall assembly where low-permeance insulation was inserted between the sheathing and framing (Assembly 2), for this particular climate, the amount of moisture accumulated within the cavity dried out during summer for any thickness of exterior insulation (Fig. 7). However, from Fig. 8, it can be seen that if the level exterior insulation is not adequate, the mold index keeps increasing from year to year and the moisture accumulated within the cavity could stimulate mold growth at XPS-Fiberglass interface.

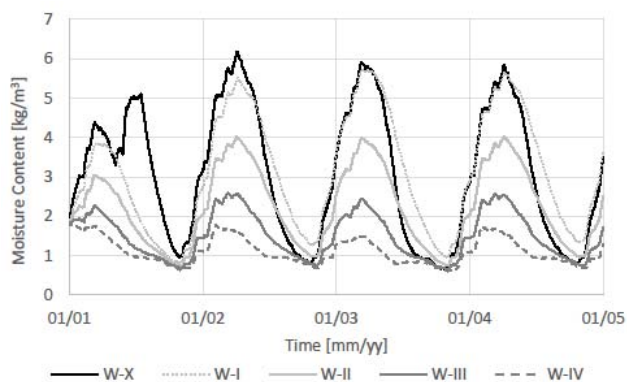

Fig. 7 Cavity moisture content (Assembly 2)

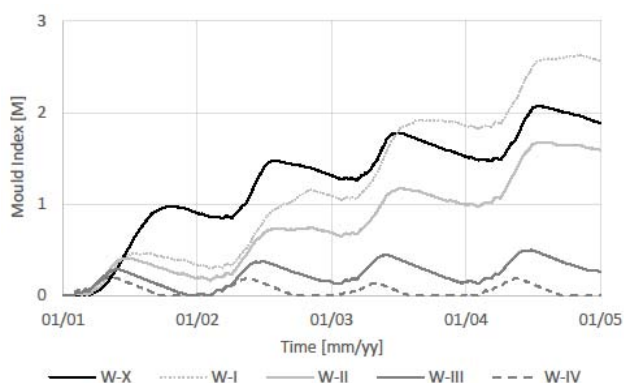

Fig. 8 Mold index XPS-Fiberglass interface (Assembly 2)

Comparing the total amount of moisture in two different wall assemblies, it can be concluded that when performance requirements (moisture content and mold growth) are met, and there is enough exterior insulation to prevent excessive moisture accumulation, both wall assemblies have similar wetting and drying potentials. The difference between two curves on the graph is due to the fact that the OSB sheathing in the Assembly 2 is much drier compared to that in Assembly 1. More specifically, in Assembly 1, most of the moisture accumulated due to the exfiltrating air and vapor diffusion is absorbed by OSB sheathing, whereas that moisture is deposited in cavity insulation in Assembly 2. The OSB in the second assembly dries out much faster and therefore, the total amount of moisture per square meter in this assembly is lower.

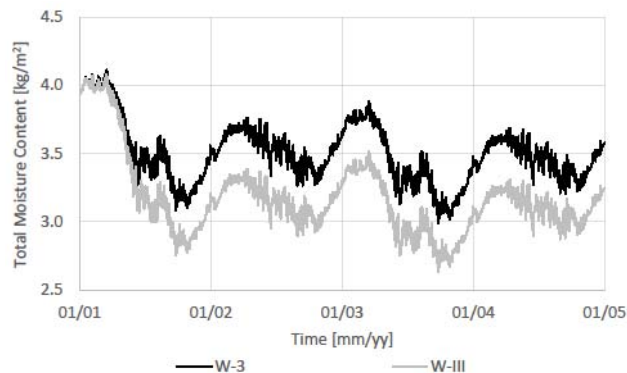

Fig. 9 Total moisture accumulation per square meter of a wall

Table VI shows the comparison of outboard to inboard insulation ratio for the two assemblies constructed with different XPS insulation thickness, for standard 2×4 and 2×6 wood-frame walls. It can be seen that putting insulation between the sheathing and framing could increase this ratio by approximately 0.07 and 0.04 for 2×4 and 2×6 stud cavity walls, respectively.

TABLE VI
RATIO OF OUTBOARD TO INBOARD INSULATION

Insulation thickness	2 × 4 Framing		2 × 6 Framing	
	Assembly 1	Assembly 2	Assembly 1	Assembly 2
12.7 mm	0.18	0.24	0.12	0.16
25.4 mm	0.34	0.40	0.22	0.26
38.1 mm	0.49	0.56	0.32	0.37
50.8 mm	0.64	0.72	0.43	0.47

Table VII summarizes the results of the analysis and recommends the minimum required outboard to inboard thermal resistance ratio that could be applied to both wall assemblies. Empty cells (-) in this table indicate that even the highest considered ratio of outboard to inboard thermal resistance (0.72) was not high enough to satisfy the performance requirements. Interior relative humidity of 55% has proven to be critical for hygrothermal performance of a wall as it would require high levels of exterior insulation to manage moisture accumulation.

TABLE VII
MINIMUM REQUIRED OUTBOARD TO INBOARD RATIO OF THERMAL RESISTANCE

Location	Interior RH 35%			Interior RH 45%			Interior RH 55%		
	Air Leakage [L/m²·s at 75 Pa]			Air Leakage [L/m²·s at 75 Pa]			Air Leakage [L/m²·s at 75 Pa]		
	0.02	0.05	0.10	0.02	0.05	0.10	0.02	0.05	0.10
Vancouver	0	0	0	0	0	0	0	0.22	0.32
Toronto	0	0	0	0	0.22	0.40	0.49	0.64	-
Ottawa	0	0	0.22	0.37	0.43	0.49	0.64	-	-
St. John's	0	0	0.22	0.37	0.43	0.49	0.64	-	-
Edmonton	0	0.22	0.32	0.43	0.49	0.64	-	-	-
Winnipeg	0.12	0.32	0.43	0.49	0.64	-	-	-	-
Fort McMurray	0.18	0.32	0.43	0.49	0.64	-	-	-	-
Yellowknife	0.40	0.49	0.64	-	-	-	-	-	-

B. Nail Joints with Insulated Sheathing

Figs. 10- 11 show the mean load-deformation responses on a per-nail basis of the tested nail joints fabricated with 16d and 10d nails, respectively. Labeling of nail joints is the same as it was for the hygrothermal analysis for Assembly 2 (i.e. W-II label represents the nail joint with 25.4 mm of intermediate insulation). Table VIII shows the mean value of the maximum recorded load from five repetitions, the associated coefficient of variation (COV) and the percentage of the load relative to the base case load (specimens without insulation layer). It can be noticed that nail joints fabricated with 10d nails (3.66 mm diameter) experienced larger drop in strength, compared to specimens with 16d nails (4.06 mm diameter), with increasing insulation thickness.

Equation (6) shows that the strength of a shear wall can be increased by using a closer nail spacing. For example, if the wall is fabricated using 16d nail (4.06 mm nail diameter) and 25.4 mm (1 in.) of intermediate insulation, a nail spacing of 74

mm would allow the shear wall to have the same shear resistance as the same shear wall without the insulation layer but a usual nail spacing of 150 mm.

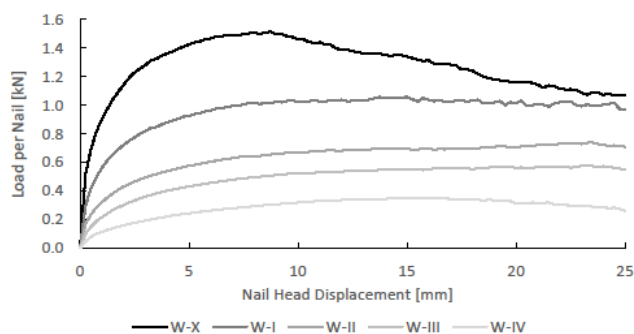

Fig. 10 Load-displacement response of nail joints with 16d nails

TABLE VIII
STRENGTH OF NAIL JOINTS WITH INSULATED SHEATHING

Nail Joint Label and Insulation thickness	10d nails			16d nails		
	Max Load [N]	COV	Load reduction [%]	Max Load [N]	COV	Load reduction [%]
W-X: no insulation	1281	0.07	100	1514	0.05	100
W-I: 12.7 mm	788	0.06	62	1060	0.11	70
W-II: 25.4 mm	513	0.06	40	740	0.09	49
W-III: 38.1 mm	-	-	-	577	0.02	38
W-IV: 50.8 mm	-	-	-	352	0.16	23

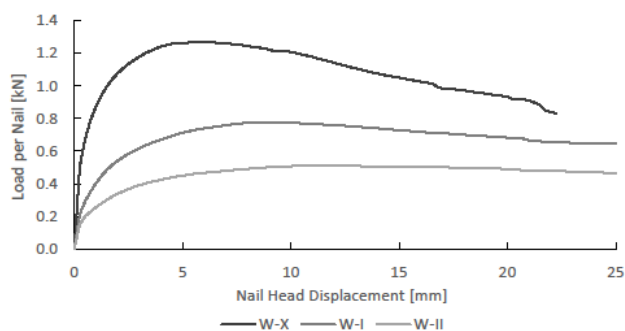

Fig. 11 Load-displacement response of nail joints with 10d nails

V. CONCLUSIONS

This study analyzed and compared two different wall assembly configurations where low-permeance XPS insulation was placed either outboard or inboard to the structural sheathing. The assembly where the sheathing is nailed directly to the framing would behave better under lateral loads, whereas inserting the insulation between the sheathing and framing could improve the construction process as different wall layers could be bonded into one panel. A one-dimensional analysis was performed for eight different locations in Canada investigating the effect of indoor relative humidity and air exfiltration rate on hygrothermal performance of the wall. The effect of insulation inserted between the sheathing and framing on structural performance

of a wall was studied by testing nail joint specimens with insulated sheathing. The following primary conclusions can be made:

Both wall assemblies accumulate the same amount of moisture interior to the low-permeance exterior insulation when the same ratio of outboard to inboard thermal resistance is used. In wall assembly where the sheathing is nailed directly to the framing, the moisture is taken on mostly by the sheathing, whereas fiber glass insulation accumulates this moisture when the low-permeance insulation is inserted between the sheathing and framing. If inadequate level of insulation is placed outboard to the sheathing the drying period could be insufficient for drying of the sheathing, and the effect of exfiltration becomes cumulative. Wall assembly where the low-permeance insulation was inserted between the sheathing and framing demonstrated a better drying potential since the accumulated moisture was able to dry out during summer when lower levels of XPS insulation were installed. However, if insufficient insulation was used wintertime relative humidity and moisture contents at XPS-Fiberglass interface were very high and there was a potential for mold growth.

Putting insulation between the sheathing and framing increases the value of the outboard to inboard insulation ratio, since the thermal resistance value of the structural sheathing is added to the outboard side. For materials and assemblies considered in this study, the increase of this ratio was approximately 0.07 and 0.04 for 2x4 and 2x6 stud cavity

walls, respectively. Placing low-permeance insulation between the sheathing and framing, however, could lead to higher cavity insulation moisture contents during the heating season which could possibly compromise the thermal conductivity of a wall.

Higher levels of interior relative humidity are critical for the overall hygrothermal performance. In these cases, using more efficient vapor and air barriers and high-permeable insulation materials on the exterior would be desirable.

It was found that the layer of intermediate insulation has a significant effect on both the stiffness and strength of nailed connections. Also, nail joint specimens fabricated with 10d nails (3.66 mm diameter) experienced larger drop in strength, compared to specimens with 16d nails (4.06 mm diameter), with increasing the thickness of insulation. More nails with a closer spacing would need to be used in order for a shear wall to retain its lateral capacity.

REFERENCES

- [1] Karagiozis, A. N. and M. K. Kumaran. 1993. "Computer Model Calculation on the Performance of Vapor Barriers in Canadian Residential Buildings" ASHRAE Transactions 99(2):991-1003.
- [2] ASHRAE. 2009a. Heat, air, and moisture control in building assemblies-Fundamentals. In: 2009 ASHRAE Handbook-Fundamentals. Atlanta: American Society of Heating, Refrigerating and Air-Conditioning Engineers, Inc. Chapter 25.
- [3] NRC. 2015a. National Building Code of Canada, National Research Council of Canada, Ottawa.
- [4] Ojanen, T. & M. K. Kumaran. 1996. Effect of Exfiltration on the Hygrothermal Behaviour of a Residential Wall Assembly. Journal of Thermal Insulation and Building Envelopes, Volume 19, pp.215-227.
- [5] Kumaran, M. K. & J. C. Haysom. 2002. Low-Permeance Materials in Building Envelopes. Construction Technology Update No. 41. National Research Council Canada.
- [6] Chown, G. A. and P. Mukhopadhyaya. 2005. NBC 9.25.1.2.: The On-Going Development of Building Code Requirements to Address Low Air and Vapour Permeance Materials. Proceedings of the 10th Canadian Conference on Building Science and Technology. Ottawa, ON.
- [7] Fraunhofer IBP. 2018. WUFI® Pro v. 6.2. Holzkirchen, Germany: Fraunhofer Institute for Building Physics.
- [8] ASHRAE 160-2016 Standard - Criteria for Moisture-Control Design Analysis in Buildings (ANSI/ASHRAE Approved), ASHRAE 2016, Atlanta, GA, 16 p.
- [9] Health Canada (2016) "Relative humidity indoors: Fact sheet." Government of Canada, Ottawa. Cat.: H144-33/2016E-PDF.
- [10] Roppel, P. J., M. D. Lawton & W. C. Brown. 2007. Modelling of Uncontrolled Interior Humidity for HAM Simulations of Residential Buildings. Thermal Performance of Exterior Envelopes of Whole Buildings X, Proceedings of ASHRAE/DOE/BTECC Conference. Clearwater Beach, FL.
- [11] Maref, W., Saber, H. H., Armstrong, M. M., Glazer, R., Ganapathy, G., Nicholls, M., Elmahdy, H., Swinton, M.C., Integration of Vacuum Insulation Panels into Canadian Wood Frame Walls, Report 1-Performance Assessment in the Laboratory, Client Report – B1253, Building Envelope Engineering Materials Program, Construction Portfolio, National Research Council of Canada, Ottawa, Canada, 2012.
- [12] Elmahdy, H., Maref, M., Saber, H. H., Swinton, M. C., and Glazer, R. "Assessment of the Energy Rating of Insulated Wall Assemblies a Step Towards Building Energy Labelling", 10th International Conference for Enhanced Building Operations (ICEBO2010), Kuwait, October 2010.
- [13] Elmahdy, A. H., Maref, W., Swinton, M. C., Saber, H. H., and Glazer, R. "Development of energy ratings for insulated wall assemblies", Building Envelope Symposium, San Diego, California, October 26, 2009, pp. 21-30.
- [14] Saber, H. H., Maref, W., Elmahdy, H., Swinton, M. C., and Glazer, R. "3D Heat and Air Transport Model for Predicting the Thermal Resistances of Insulated Wall Assemblies", International Journal of Building Performance Simulation, First published on: 24 January 2011 (iFirst), Vol. 5, No. 2, p. 75–91, March 2012.
- [15] Saber, H. H., Maref, W., Elmahdy, A. H., Swinton, M. C., and Glazer, R. "3D Thermal Model for Predicting the Thermal Resistances of Spray Polyurethane Foam Wall Assemblies", Building XI conference, Clearwater, Florida, 2010.
- [16] Saber, H. H., Maref, W., Abdulghani K., "Report on Properties and Position of Materials in the Building Envelope for Housing and Small Buildings", National Research Council Canada, December 2014.
- [17] Carll, C. G.; Highley, T. L. 1999. Decay of wood and wood-based products above ground in buildings. Journal of Testing and Evaluation. 27(2):150–158.
- [18] Ojanen, T., Viitanen, H. A., Peuhkuri, R., Lähdesmäki, K., Vinha, J., and Salminen, K., "Mold Growth Modeling of Building Structures Using Sensitivity Classes of Materials", 11th International Conference on Thermal Performance of the Exterior Envelopes of Whole Buildings XI (Clearwater, (FL), USA, December-05-10), 10 p., 2010
- [19] CSA. 2014. Engineering design in wood. CSA O86-14. Canadian Standards Association, Toronto, ON.