

The Potential of Hybrid Microgrids for Mitigating Power Outage in Lebanon

R. Chedid, R. Ghajar

Abstract—Lebanon electricity crisis continues to escalate. Rationing hours still apply across the country but with different rates. The capital Beirut is subjected to 3 hours cut while other cities, town and villages may endure 9 to 14 hours of power shortage. To mitigate this situation, private diesel generators distributed illegally all over the country are being used to bridge the gap in power supply. Almost each building in large cities has its own generator and individual villages may have more than one generator supplying their loads. These generators together with their private networks form incomplete and ill-designed and managed microgrids (MG) but can be further developed to become renewable energy-based MG operating in island- or grid-connected modes. This paper will analyze the potential of introducing MG to help resolve the energy crisis in Lebanon. It will investigate the usefulness of developing MG under the prevailing situation of existing private power supply service providers and in light of the developed national energy policy that supports renewable energy development. A case study on a distribution feeder in a rural area will be analyzed using HOMER software to demonstrate the usefulness of introducing photovoltaic (PV) arrays along the existing diesel generators for all the stakeholders; namely, the developers, the customers, the utility and the community at large. Policy recommendations regarding MG development in Lebanon will be presented on the basis of the accumulated experience in private generation and the privatization and public-private partnership laws.

Keywords—Decentralized systems, microgrids, distributed generation, renewable energy.

I. INTRODUCTION

THE continued development of renewable energy technologies coupled with the massive decrease in their capital cost, has accelerated the deployment of such technologies operating both as off-grid and grid-connected green systems [1], [2]. The most remarkable change occurred in the PV industry when the average cost of solar PV modules fell by nearly 80% between 2009 and 2014 [3]. The lowest bid price recorded so far was US\$0.0179 per kWh in 2017 for a 300 MW utility-scale solar project in Saudi Arabia submitted by Abu Dhabi's renewable energy company Masdar and its French partner EDF [4].

In recent years, several authors have addressed the design [5], [6], component sizing [7] and energy flow management of hybrid renewable energy systems using optimization or simulation techniques [8], [9]. The literature has documented the rise of MG [10], [11] and community grids (CG) [12]-[15]

R. Chedid is with the American University of Beirut, Beirut, Lebanon (corresponding author, phone: +961 1 350000; fax: +961 1 744462; e-mail: rchedid@aub.edu.lb).

R. Ghajar is with the Lebanese American University, Byblos, Lebanon (e-mail: rghajar@lau.edu.lb).

that implement PV as well as other distributed energy resources (DERs). These small to medium size systems normally operating at the distribution level have changed the world's understanding of power system planning and paved the way for the development of decentralized systems as opposed to the classically centralized ones [12]. The integration of distributed generators (DGs) in distribution systems has actively led the development of MGs and addressed the associated energy, economics, and environmental issues and enhanced the availability of electricity supply during outage hours [10], [13], [16]. The authors in [12] have addressed the practical issues that need to be tackled when establishing MG such as the peculiarities of different business models, distribution control strategies and local marginal pricing. Reference [10] presents a multi-objective optimization algorithm based on interactive fuzzy method to cluster existing distribution systems into a set of MGs and applied it to the IEEE 34-bus distribution system.

The electricity sector in Lebanon has been suffering from power shortages and regular outages for several decades [17]-[19]. Several attempts to develop the sector using the existing vertical hierarchy failed to achieve their objectives and pushed the sector further into debt and poorer quality of service [20]-[22]. These failures did not stop the private sector and citizens at large from seeking alternative energy supplies using private diesel generators, renewable energy sources and other community-based power supplies that can be classified as informal MGs [23], [24].

This paper will analyze the potential of introducing MG to help resolve the electricity supply crisis in Lebanon based on current practices of the private sector in diesel generation power supply and distribution network management. A case study on 10 villages connected to a distribution feeder and having backup diesel generators will be analyzed with and without PV units using the HOMER software, and the simulation results will be used to assess the benefits of converting the existing system into a community MG.

II. THE PROGRESS OF MG DEVELOPMENT IN LEBANON

Several studies have attempted to assess the benefits of operating renewable energy systems along the existing diesel generators in Lebanon [24]-[26]. In fact, hybrid PV-diesel generation systems with sophisticated energy flow management have been in operation for years in Lebanon but only for private applications. These include university campuses, malls, touristic complexes, etc. [27]. In such applications, diesel generators run in parallel with PV arrays to supply the load when the grid is on outage [28], [29]. In

some cases, where a net metering license is granted, the PV system is allowed to supply the grid. In addition, it is remarkable to notice that the majority of buildings in Beirut and large cities have their own diesel generators with capacity ranging from 100 kVA to 200kVA. Furthermore, most of the villages and towns have private diesel generators operating without license and supplying the customers during rationing hours.

Although private diesel generators are not legally licensed, they continue to provide an essential service during the outage times imposed by the electric utility (EDL) or caused by forced outages. This has somehow justified their existence from the perspective of local authorities and municipalities who took the initiative of installing their own generators and/or allowing the operation of private generators within their jurisdictions and imposing some control over the tariff [30]. This paper is proposing to use these types of generators to investigate the benefits of integrating them within a renewable energy-based MG. The authors of this paper believe that a move towards MGs is warranted for the following reasons:

1. The long years of private generators operation have created an economic niche market in which thousands of businessmen, operators and technicians have made a living.
2. The large market has enabled the availability of professional knowhow in the fields of diesel generators O&M and network servicing and billing.
3. The continued decline in renewable energy technologies costs and the incentives established by NEEREA [27] have made it possible to develop several pilot projects which clearly showed the distinctive advantage of using PV, micro-hydro and wind turbines along the diesel backup generators to reduce the cost of electricity and enhance the reliability of supply.
4. The widespread usage of diesel generators as backup supply and the involvement of municipalities, small local businessmen and non-governmental organizations in the development and operation of such generators makes MGs a feasibly solution to the electricity crisis in Lebanon for communities who are willing to invest in RE technologies alongside their existing diesel generators.
5. The MG may incorporate prosumers who generate their own energy from renewable energy systems using their rooftops or unexploited land and either store the surplus energy for future use or sell it using net metering to the utility grid or to the MG providers [16].

III. CASE STUDY

The aim of the case study is to examine the benefits of installing PV arrays to complement diesel generators operating in the 10 villages supplied by Rashaya feeder in Rashaya district located in the south of Bekaa Governorate in Lebanon. The objectives of the case study are as follows:

- To assess the economic benefits of redesigning the existing system as a MG having PV arrays complementing the private diesel generators supply of electricity

- To highlight the legal and technical problems of the private generation business whose solutions will facilitate the move towards MG
- To recommend a policy framework to enable developing and managing private sector investment in power generation and distribution through the concept of MG

A. Energy Supplied by the Grid and the Private Diesel Generators

The average energy supplied by the utility distribution feeder in Rashaya in 2016 was 18.5 GWh/yr. During power outages, the power demand is met by 25 diesel generators whose individual rated capacity ranges from 100 kW to 250 kW. The energy supplied by the diesel generators combined for 4380 hours of outage is 18.38 GWh per year. Hence, the total energy supplied by EDL grid and the diesel generators is 36.88 GWh per year.

B. Load Profile

The seasonal average power demand profiles for 2016 shown in Fig. 1 were provided by EDL. It is clear from these profiles that the peak demand occurs around noon and 8 PM. At noon, solar irradiance is high and PV resources will be useful to meet the demand requirements.

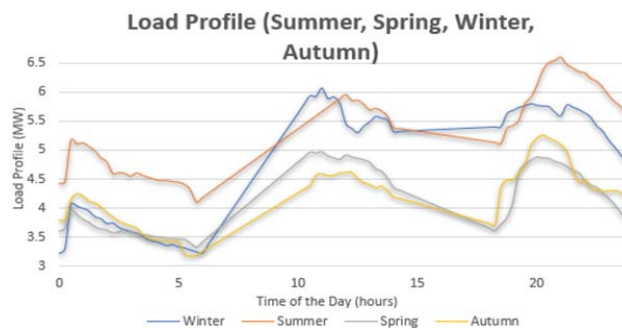

Fig. 1 Rashaya feeder load profile

The load characteristics of the Rashaya feeder are summarized in Table I.

TABLE I
 RASHAYA FEEDER LOAD CHARACTERISTICS

Peak Load	6.6 MW
Average Load	4.2 MW
Peak Month	August
Load Factor	0.64
Yearly Energy	36.88 GW

C. Proposed Upgrade of the Existing System

The current system of diesel generators uses privately wired aerial network to distribute their energy instead of the utility-owned distribution network because they operate without a license. To convert the existing system into a MG, a new PV power plant will be established and the existing diesel generators operating individually in the villages will be clustered in one diesel power plant. Both plants will be connected to the MV bus as shown in Fig. 2 [24]-[26]. The PV arrays are connected to a DC bus and a converter is used to

connect the DC and AC bus and transfer power between them. The diesel power plant is connected to the AC bus using a transformer.

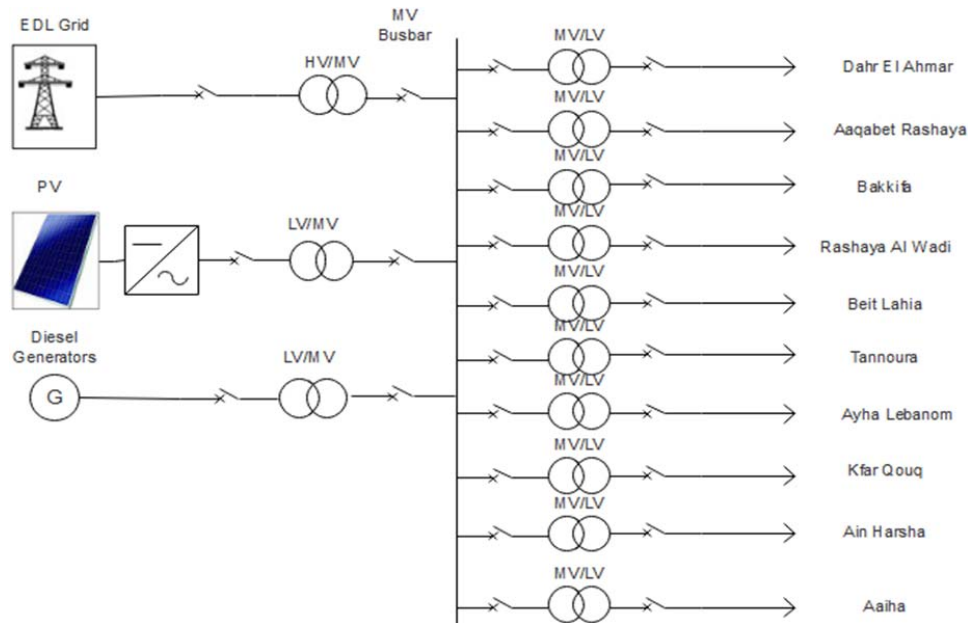

Fig. 2 The proposed micro-grid for Rashaya

IV. SYSTEM MODELING USING HOMER

This paper uses the HOMER software [25], [9] to study the proposed system shown in Fig. 2. The 10 villages are assumed to have similar solar resources, similar load nature and same rationing hours. The system will be analyzed at the feeder level as a community MG after adding the loads of the 10 villages, the diesel generators' and the PV arrays capacities.

A. Priority of Operation

Since the proposed MG system has multiple sources of energy supply, the highest priority is given to the PV system. If the PV power is greater than the load demand, the excess power will be sent to the grid if available or dumped in case the grid is off. When the PV system cannot meet the load demand, the balance will be supplied by the grid whenever it is available and from the diesel generators at all other times. Power supply from the PV system to the grid is only possible through net metering. According to the net metering policy of EDL, reconciliation is performed annually. If net energy is bought from the grid, the customer pays for it using a set tariff; however, if net energy is sold to the grid, no payment by EDL is due to the customer. Thus, it is important not to oversize the PV system.

B. PV Modules

A 300-Watt Mono Crystalline module is used as a basis for the HOMER simulation. The characteristics of the selected modules are summarized in Table II.

The cell temperature at PTC is 51.25 °C. With a power loss due to temperature effect of 0.39 %/°C, the module DC Power under PTC is 269.3W. Assuming that the combined dirt and mismatch losses amount to 12% and the inverter

efficiency is 95%, the module AC power produced under PTC is 225W. To replace the energy supplied by diesel generators in the 10 villages of the Rashaya feeder, the proposed PV power plant must supply an average of 18.38 GWh/year. The capacity of the PV power plant required to produce this energy annually under the PTC is 13.79 MW and the area required is 76,611 m².

TABLE II
 PV MODULE CHARACTERISTICS

Characteristic	Value
Power (W)	300
Capital Cost (\$/kW)	800
Efficiency (%)	18
NOCT (°C)	45
Temperature Effect on Power (%/°C)	-0.39

C. EDL Grid

The distribution feeder supplying Rashaya has around three daily outages of around 4 hours each. The number of outages per year is around 1100.

D. Diesel Generators

Diesel generators used in Rashaya are operated by private service providers with a production cost of around US\$0.216/kWh which largely represents the cost recovery of fuel, oil filter and other operating expenses. The initial capital cost of the diesel generators is assumed to be zero since all such generators have been purchased and largely amortized and so only generators' replacements are considered at a cost of US\$150/kW. The minimum loading allowed for a diesel generator 40% of its rated capacity.

V. SIMULATION RESULTS

System simulation was carried out in HOMER under market price value of PV modules and diesel generators, a discount rate of 8%, and an inflation rate of 2%. A study period of 25 years was used together with a maximum allowed annual power shortage of 0.5% for maintenance and forced outages. The cheapest system in terms of net present cost and levelized cost of electricity is the hybrid grid-connected system with PV and diesel generators as compared to the existing case of grid-diesel generator scheme only. This system is composed of 13.8 MW of dc PV power (under STC) built from 45,967 modules priced at US\$800/kW leading to a total PV capital cost of US\$11.04 million. The diesel generators set has a total capacity of 6.7MW, the converter has a capacity of around 10 MW and the grid is considered of infinite capacity.

The simulation of the proposed MG system resulted in electricity production cost of US\$0.132/kWh compared to the US\$0.157/kWh when only the grid and diesel generators are used. The PV arrays produce 17 GWh/year which is 46.1 % of the total energy demand and operate for 4348 hours/year demonstrating a capacity factor of 18.7%. The diesel generators produce 11.8 GWh/year and have the lowest utilization as they only operate when the grid is off, and the PV system is unable to supply all or part of the load demand. These generators operate 3225 hours/year with a production cost of US\$0.216/kWh. Around 11.9 GWh/year are purchased from the grid and 3.88 GWh/year are supplied back through net metering resulting in a net grid energy supply of 8 GWh/year.

A. Utility Benefits

The current Lebanese system has an average production cost of electricity of US\$0.13/kWh, whereas the average electricity tariff set by EDL is US\$0.0987/kWh. If the technical and non-technical losses are taken into consideration [17], the production cost of 1 kWh fed by EDL to the load is US\$0.1688/kWh. The net present cost of the proposed system is US\$69.6 million compared to the US\$90.5 million of the existing one. The payback period is 5 years and the return on investment is 16.2% which is considered economically attractive. The results of energy and economic analyses provided by HOMER are summarized in Table III.

TABLE III
HYBRID PV-DIESEL-GRID SYSTEM ECONOMICS

Metric	Value
Present worth (\$)	\$20,982,410
Annual worth (\$/yr)	\$1,623,081
Return on investment (%)	16.2%
Internal Rate of Return (%)	20.2%
Simple Payback period (yr)	5.00
Discounted payback period (yr)	6.05

Since EDL sells electricity at US\$0.0987/kWh which is below its production cost, the deficit increases as more energy is produced. So, by developing the proposed system, the PV arrays will reduce the energy supplied by the grid in Rashaya

from 18.5 GWh/year to a net 8 GWh/year. Hence, EDL's yearly debt will be reduced by $\Delta(debt) = (18.5 - 8) \times (0.13 / 0.77 - 0.0987) \times 10^6 = US\0.74 million. Moreover, since the 18.5 GWh required by the customers are transmitted and distributed with 23% technical and non-technical losses, the equivalent energy required by the power plants is 24 GWh/year. By implementing the proposed MG, the energy required from EDL plants is reduced to 10.34 GWh/year assuming rate of losses remains fixed. This will result in a reduction of fuel purchases required by EDL thermal power plants and less emissions.

B. Customer Benefits

Customers in Rashaya currently pay an average of US\$0.157/kWh for electricity supplied almost equally by EDL and diesel generators. If the proposed MG is implemented, the electricity price drops to US\$0.132/kWh. Since the total energy required by the area is 36.88GWh/year, this will result in yearly savings to the customers of $\Delta(Price) = US\$0.885$ million. Considering that there are around 3000 household-type customers in the 10 villages, the saving per household will be around $\Delta(household) = 295\$$ per year.

VI. POLICY FRAMEWORK FOR MG DEVELOPMENT IN LEBANON

EDL has introduced private sector participation in the distribution network since 2012 using the concept of Service Providers which perform similar activities to the concessions but without being granted long term contracts nor owning the assets [31]. The scope of activities of the service providers were supposed to be paid from the annual improvements that they make on a number of key performance indicators established for a baseline period.

On the other hand, diesel generators have been operating illegally in villages and towns as a de facto situation raising concern about power supply quality, safety, emissions and unfair tariff. Their services will continue in the absence of alternatives but their legal status has to be resolved. The current diesel generators operating without license are not allowed to use the utility distribution networks. Rather they wire their own aerial networks including installing their own meters and impose their own tariffs which differ from one place to another. This situation makes it impossible to make serious investments to improve service, modernize assets and enhance protection and control via energy management systems, smart meters and a real-time control and communication systems.

The main problem causing the illegal operation of private generators and hence the development of MG is rooted in the privatization law #462 which was ratified and promulgated by Parliament in 2002 but never implemented. This law does not include specific articles on renewable energy based MG. Rather, it calls on the privatization of the entire distribution network following the classical approach of privatization and only allows private generation up to 1.5 MW for personal use. The development of any form of IPP beyond the 1.5 MW requires a license from the Energy Regulatory Authority

which has not been established due for political reasons. This politically rooted problem constitutes the main obstacle for private sector participation in the decentralization of the electricity sector. A temporary solution to this problem was introduced via laws 288/2014 and 54/2015 which allow the Minister of Energy and Water to grant permits to IPPs pending approval of the amendments to law 462 and the formation of the Regulatory Authority. The authors of this paper recommend a similar approach to institutionalize the MG development in Lebanon and avoid the unsustainable and chaotic development of the existing private power generation market.

The above temporary laws together with the recently passed Public Private Partnership (PPP) Law 48/2017, can be used to legalize the operation of the existing system and the future privately owned diesel generators which can be organized in close cooperation with the utility to pave the way for the development of efficient renewable energy based MG in Lebanon. If this materializes, owners of private generators can then use the utility distribution network, install energy management systems to manage power flow including reactive power, establish a control center to serve the multiple generators supplying clusters of customers fed from the same feeder or from multiple feeders and help the utility manage its power supply during peak time. In brief, they will be able to operate as renewable energy based MG service providers that will be subjected to strict regulations preventing unfair tariff and low quality power supply and serve both the customers and the utility.

Several business models can facilitate the development of MGs in Lebanon including:

- A municipality MG
- A MG concession
- A private (gated) community MG

In the above business models, the development of RE based power plants and diesel backup power may be secured either by lease contracts, management contracts and PPP agreements.

VII. CONCLUDING REMARKS

This paper has addressed the status of MG development in Lebanon as a potential solution to solve the power supply problem at the distribution level. A case study on a feeder supplying 10 villages in Rashaya district located in the south of Bekaa governorate was presented where diesel generators are used to supply power during rationing hours. It was demonstrated that the introduction of a PV power plant alongside a diesel power plant resulted in an average production cost that is lower than the utility tariff including T&D losses. The paper also showed that additional benefits would result in terms of reducing the power production requirements which would lead to reduction in utility debt and in harmful emissions. The paper used the case study simulation results using HOMER to highlight a policy framework to legally develop MG in Lebanon by the private sector and in close cooperation with the utility on the basis of the accumulated experience of private sector involvement in

the electricity sector and the recently approved public private partnership law. The proposed framework builds on the facts that (1) Lebanon has acquired very good experience in MG development and operation for private applications, (2) the government has made commitment to and provided incentives for promoting renewable energy for power generation, (3) the country has accumulated experience and expertise in operating and maintaining diesel generators and distributing energy for public although illegally and (4) there is a proven record of power sector participation in the electricity sector management through the private concessions and distribution service providers.

Future work is still needed to address technical requirements and business models to properly develop MG and fully assess their role in the future power systems of Lebanon.

ACKNOWLEDGMENT

The authors would like to acknowledge the contribution of Mr. E. Libbos and Ms. D. Haidar in data collection and HOMER simulation.

REFERENCES

- [1] S. Shezan, S. Julai, M. Kibria, K. Ullah, R. Saidur, W. Chong and R. Akikur, "Performance analysis of an off-grid wind-PV (photovoltaic)-diesel-battery hybrid energy system feasible for remote areas," *Journal of Cleaner Production*, vol. 125, pp. 121-132, 2016.
- [2] Kaabeche and R. Ibtouen. Techno-economic optimization of hybrid photovoltaic/wind/diesel/battery generation in a stand-alone power system. *Solar Energy*, vol. 103, pp. 171-182, 2014.
- [3] Steven Griffiths. A review and assessment of energy policy in the Middle East and North Africa region. *Energy Policy* 102 (2017) 249–269.
- [4] <https://www.thenational.ae/business/energy/world-s-cheapest-prices-submitted-for-saudi-arabia-s-first-solar-project-1.663842>.
- [5] Jaesung Jung, Michael Villaran. Optimal planning and design of hybrid renewable energy systems for microgrids. *Renewable and Sustainable Energy Reviews* 75 (2017) 180–191.
- [6] B. Madaci, R. Chenni, E. Kurt and K. E. Hemsas, "Design and control of a stand-alone hybrid power system," *International Journal of Hydrogen Energy*, vol. 41, no. 29, pp. 12485-12496, 2016.
- [7] Raji Atia and Noboru Yamada. Sizing and Analysis of Renewable Energy and Battery Systems in Residential Microgrids. *IEEE Transactions On Smart Grid*, Vol. 7, No. 3, May 2016.
- [8] Fares, D., S. H. Karaki and R. Chedid, 2011. Design and Simulation of a Hybrid Renewable Energy System. *IEEE Power & Energy Conference at Illinois (PECI 2011)*, Urbana Champaign, Illinois.
- [9] S. Bahramara, M. P. Moghaddam and M. Haghifam. Optimal planning of hybrid renewable energy systems using HOMER: A review. *Renewable and Sustainable Energy Reviews*, vol. 62, pp. 609-620, 2016.
- [10] Saeed Hasanvand, Majid Nayeripour, Eberhard Waffenschmidt, Hossein Fallahzadeh-Abarghouei. A new approach to transform an existing distribution network into a set of micro-grids for enhancing reliability and sustainability. *Applied Soft Computing* 52 (2017) 120–134.
- [11] Xiaojuan Han, Hua Zhang, Xiaoling Yu, Lina Wang. Economic evaluation of grid-connected micro-grid system with photovoltaic and energy storage under different investment and financing models. *Applied Energy* 184 (2016) 103–118.
- [12] Lei Wu, Tom Ortmeier, Jie Li. The community microgrid distribution system of the future. *The Electricity Journal* 29 (2016) 16–21.
- [13] Peigen Tian, Xi Xiao, Kui Wang, Ruoxing Ding. A Hierarchical Energy Management System Based on Hierarchical Optimization for Microgrid Community Economic Operation. *IEEE Transactions On Smart Grid*, Vol. 7, No. 5, September 2016.
- [14] Emi Minghui Guia, Mark Diesendorf, Iain MacGill. Distributed energy infrastructure paradigm: Community microgrids in a new institutional

- economics context. *Renewable and Sustainable Energy Reviews* 72 (2017) 1355–1365.
- [15] Peigen Tian, Xi Xiao, Ying Chen, Tianjun Jing, Xiuqiong Huang, Nazhi. The key technologies and analysis of research state of microgrid community. *Resources, Conservation and Recycling* 121 (2017) 56–63.
- [16] Won-Poong Lee, Jin-Young Choi, Dong-Jun Won. Coordination Strategy for Optimal Scheduling of Multiple Microgrids Based on Hierarchical System. *Energies* 2017, 10, 1336. doi:10.3390/en10091336.
- [17] J. Khoury, R. Mbayed, G. Salloum, E. Monmasson, J. Guerrero. Review on the integration of photovoltaic renewable energy in developing countries—Special attention to the Lebanese case. *Renewable and Sustainable Energy Reviews* 57 (2016) 562–575.
- [18] Nathaniel J. Williams, Paulina Jaramillo, Jay Taneja, Taha Selim Ustun. Enabling private sector investment in microgrid-based rural electrification in developing countries: A review. *Renewable and Sustainable Energy Reviews* 52 (2015) 1268–1281.
- [19] Oussama Ibrahim, Farouk Fardoun, Rafic Younes, Hasna Louahli-Gualous. Energy status in Lebanon and electricity generation reform plan based on cost and pollution optimization. *Renewable and Sustainable Energy Reviews* 20 (2013) 255–278.
- [20] Lebanon: Energy sector in urgent need of a reform. <http://www.folkcenter.dk/mediafiles/folkcenter/pdf/LEBANON.pdf>.
- [21] H.A. Hamdan, R.F. Ghajar, R.B. Chedid. A simulation model for reliability-based appraisal of an energy policy: The case of Lebanon. *Energy Policy* 45 (2012) 293–303.
- [22] R. H. El-Fadel, G. P. Hammond, H. A. Harajli, C. I. Jones, V. K. Kabakian, A. B. Winnett. The Lebanese electricity system in the context of sustainable development. *Energy Policy* 38 (2010) 751–761.
- [23] World Bank, 2008. Republic of Lebanon Electricity Sector: Public Expenditure Review, Report no. 41421-LB. World Bank, Washington.
- [24] Adnan Zein, Ghassan Bazzoun. Integration of Photo voltaic Generators into Existing Diesel Mini-Grids in Lebanon. 25th International Conference on Microelectronics (ICM), 2013.
- [25] R. Chedid, I. Baydoun, S. Eid, S. Tarhini, R. Ghajar. Techno-Economic Analysis of a PV Generator Operating in a Hybrid Diesel-Unreliable Grid System. 2015 International Conference on Clean Electrical Power (ICCEP).
- [26] Ali Assi and Omar Al-Kaaki. Introducing Micro-grids in Lebanon Renewable-Based Microgrids to Replace Diesel Generators. 2016 3rd International Conference on Renewable Energies for Developing Countries (REDEC), 2016.
- [27] W. Thornton. Strategic Niche Management of the Solar Electricity sector in Lebanon. CEDRO report. Exchange issue 22. July 2016. www.cedro-undp.org.
- [28] Hassan Harajli, Fabiana Gordon. Willingness to pay for green power in an unreliable electricity sector: Part 2. The case of the Lebanese commercial sector. *Renewable and Sustainable Energy Reviews* 50 (2015) 1643–1649.
- [29] Leila Dagher, Hassan Harajli. Willingness to pay for green power in an unreliable electricity sector: Part 1. The case of the Lebanese residential sector. *Renewable and Sustainable Energy Reviews* 50 (2015) 1634–1642.
- [30] Dana Abi Ghanem. Energy, the city and everyday life: Living with power outages in post-war Lebanon. *Energy Research & Social Science*. In press, corrected proof, Available online 26 November 2017.
- [31] MEW. Policy paper for the electricity sector. Report #1. Beirut: Ministry of Energy and Water (MEW). 2010.