

Flexible Technologies of Granulated Complex Fertilizers

Andrey M. Norov, Denis A. Pagaleshkin, Pavel S. Fedotov, Viacheslav M. Kolpakov, Konstantin G. Gorbovskiy

Abstract—The article focuses on the latest research and developments (R&D) aimed at the development of plants for production of complex phosphorus-containing fertilizers which are in line with the principles of the best available techniques (BAT). The advantages of the implemented technical solutions are given. The paper describes developed options of flexible technologies for schemes with DGD (drum granulator dryer) and for schemes with AG-DD (ammoniator-granulator and dryer drum).

Keywords—Ammoniator-granulator and dryer drum, drum granulator dryer, phosphorus-containing fertilizer technology, PK-, NPK-, PKS- and NPKS-fertilizers, wet phosphoric acid.

I. INTRODUCTION

IN recent years, with the purpose to better satisfy the needs of agricultural producers, and also to improve fertilizers quality characteristics, reduce the product cost, and improve safety of the fertilizers production processes, several advanced flexible technologies for fertilizer producers have been developed, two of which will be presented below.

II. FLEXIBLE TECHNOLOGY BASED ON THE SCHEME WITH DGD

The first area of focus concerns flexible technologies of phosphorus-potassium fertilizers, containing sulfur (PKS) based on calcium phosphates and potassium chloride, as well as of complex nitrogen-phosphorus-potassium fertilizers, containing sulfur (NPKS) based on calcium and ammonium phosphates with the equipment combining the stages of granulation and drying, i.e. DGD. More detailed information on the equipment and its application in the technology of mineral fertilizers was presented at “SYMPHOS 2017” conference [1]. In Fig. 1 a DGD scheme is given.

Only by adjusting the ratio of initial components, the technologies enable to produce a wide range of different grades of PKS- and NPKS-fertilizers: 0-20-20(5S), 0-15-15(9S), 0-24-24(2S), 0-15-30(4S), 0-20-30(2S), 1-20-20(5S), 5-20-20(5S), 5-15-30(5S), 10-15-15(10S), 4-30-10(5S), 4-30-15(3S), 5-25-15(5S), 12-17-17(9S), 10-10-20(10S), 8-16-16(9S), 6-20-30(3S), etc. The process flow scheme of PKS- and NPKS-fertilizers production is given in Fig. 2.

The process of PKS-fertilizers production consists in neutralization of wet phosphoric acid (WPA) or its mixture with sulfuric acid by calcium carbonate, followed by introduction of potassium chloride into the neutralized slurry. Sulfuric acid is used as a source of sulfur, and it can be

replaced by calcium sulfate. To produce NPKS-fertilizers, ammonium sulfate is added to the neutralized slurry in addition to potassium chloride. When all raw components are added, the slurry is pumped for granulation and drying into the DGD, where it is sprayed from the nozzle onto the curtain of the returned fines. After drying and screening, the granules of final fraction are directed for cooling and surface conditioning, whereas fine fraction together with the coarse fraction after grinding are returned to the head of the DGD.

To produce popular grades of fertilizers, the flexible technology of PKS-, NPKS-fertilizers makes it possible to use as a feedstock not only non-concentrated WPA, but also a suspension (slurry) from WPA production, that contains calcium sulfate. Also, it is possible to process a number of various wastes from mineral fertilizers and salts production, for example, conversion chalk, which is a waste of complex fertilizers production by decomposition of phosphate raw materials by nitric acid. Moreover, there can be processed phosphogypsum and various phosphorus-containing sludges, for example, from sodium tripolyphosphate production, etc. Furthermore, it is possible to use various natural phosphate raw materials as one of the sources of phosphorus. In this case, a stage of phosphate raw material decomposition by a mixture of WPA and sulfuric acid is added to the process.

Complex PKS- and NPKS-fertilizers are characterized by good physical and mechanical properties, the granules are spherical, of high strength and homogeneous in terms of granulometric and chemical composition with a low tendency to dustiness and very low tendency to caking. Due to that, complex PKS- and NPKS-fertilizers are of much superior quality compared to similar products produced by a dry blending method. The costs related to the introduction of fertilizers into the soil substantially decrease, the uniformity of distribution and the nutritive efficiency for the plants grow. The images of granules of various grades of PKS- and NPKS-fertilizers are given in Fig. 3.

Based on the results of laboratory and field agrochemical tests, it is found that in terms of effectiveness, complex PKS- and NPKS-fertilizers are not inferior compared to bulk blended fertilizers of similar grades based on triple superphosphate and monoammonium phosphate (MAP), but vice versa, they are superior. The results of laboratory and field agrochemical tests are presented in Table I. Besides, it was seen that PKS-fertilizers are characterized by a slow-release effect. This effect is durable, therefore PKS-fertilizers continue to provide plants with nutrients gradually at least during one year after they are introduced into the soil.

A.M. Norov is the Industrial Technology Director of JSC “NIUIF” (75 Severnoye Hwy, Cherepovets, Vologda region, Russia, 162622) (phone: +7 8202 592508; e-mail: ANorov@phosagro.ru).

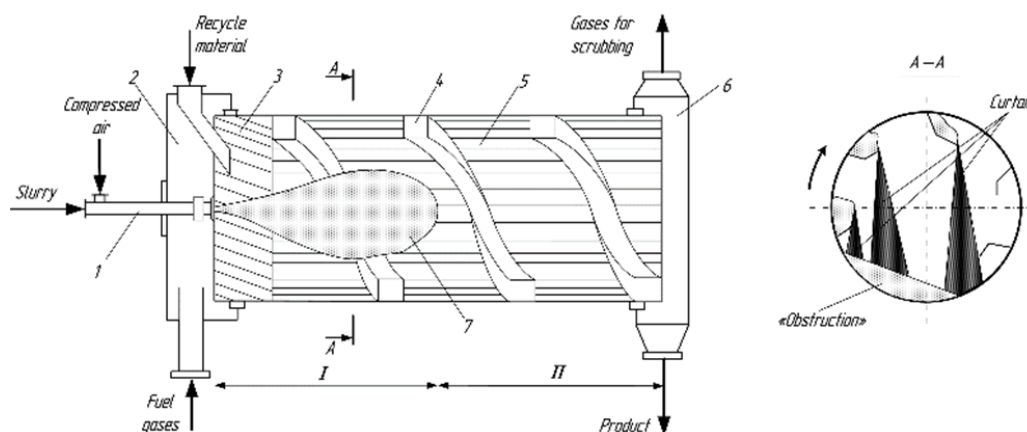

Fig. 1 DGD: 1 - nozzle, 2 - loading chamber, 3 - screw feeder, 4 - reverse screw, 5 - flat lifting plate, 6 - discharge chamber, 7 - jet, I - granulation section; II - drying section

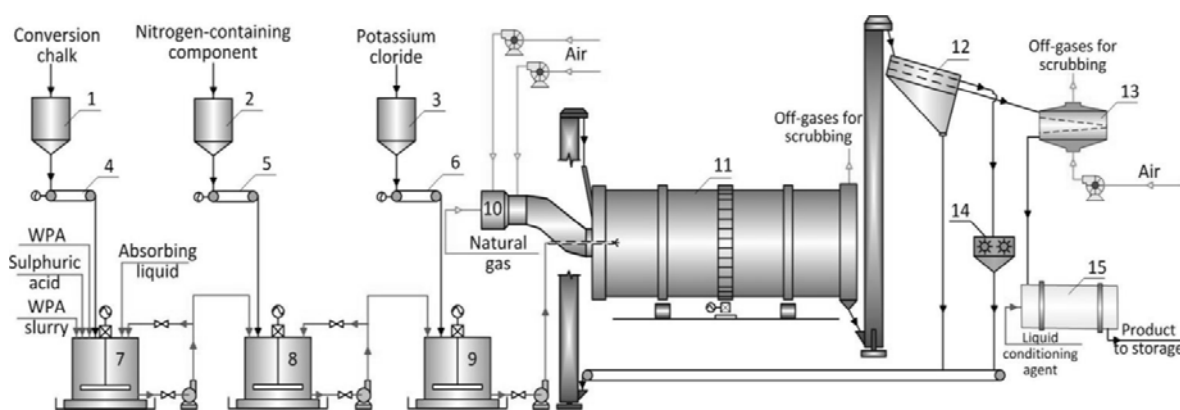

Fig. 2 Scheme of production of PKS, NPK-fertilizers based on calcium phosphates: 1-3 –feed tanks, 4-6 –weight feeders, 7-9 –reactors, 10 – burner, 11 –DGD, 12 –screen, 13 –fluidized bed cooler, 14 –crusher, 15 –conditioning drum

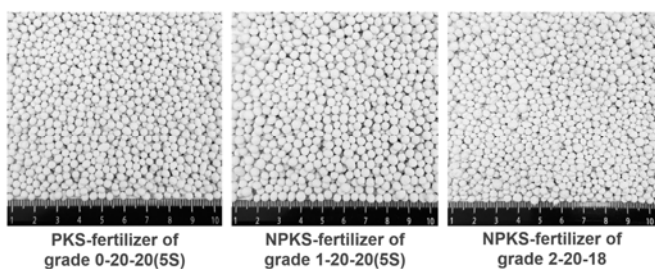

Fig. 3 Images of granules of PKS- and NPKS-fertilizers of various grades

TABLE I

RESULTS OF LABORATORY VEGETATION TEST WITH PKS-FERTILIZER 0-20-20(5S)

Source of N	Sources of P ₂ O ₅ , K ₂ O & S	Average weight of barley plants, g/vessel	Average harvest of barley grains, g/vessel	Average harvest of colesseed, green mass, g/vessel
NH ₄ NO ₃	PKS-fertilizer 0-20-20(5S)	42.9	24.0	38.8
	Triple superphosphate, KCl, gypsum	40.4	21.9	38.6
	KCl, gypsum	32.3	18.0	21.7

The slow-release effect of PKS-fertilizer occurs due to a

dense frame of poorly soluble calcium sulfate in the structure of the granule, which prevents premature leaching of soluble fertilizer components. The nutrients' release rates can be adjusted by changing the amount of calcium carbonate supplied for neutralization of acids mixture, also by changing the product particle size composition and introducing nitrogen-containing additives into it.

An increase in the amount of calcium carbonate leads to an increase in the content of poorly water-soluble dicalcium phosphate in the product, which is easily assimilated by plants. Fig. 4 shows a characteristic curve of the relative content of phosphorus in water-soluble and plant-assimilable forms, depending on the amount of calcium carbonate introduced. It can be seen that with an increase of calcium carbonate amount, the content of a water-soluble form of phosphorus decreases, while the content of assimilable form stays almost the same. At the same time, the amount of calcium carbonate shall be enough to neutralize a mixture of WPA and sulfuric acid. In the process of neutralization, calcium sulfate and monocalcium phosphate are generated.

Fig. 5 shows the characteristic curves of the granules' dissolution rates in water for PKS- and NPKS-fertilizers of various grades. For comparison, the data for NPK-fertilizers of the most popular grades are also given. From the data

provided, it is clear that an increase in the average diameter of the granule of PKS- and NPKS-fertilizers leads to a decrease in its dissolution rate. Based on the results of lab vegetation

tests, it is also proved that bigger granules are characterized by a more express durable effect of slow-release.

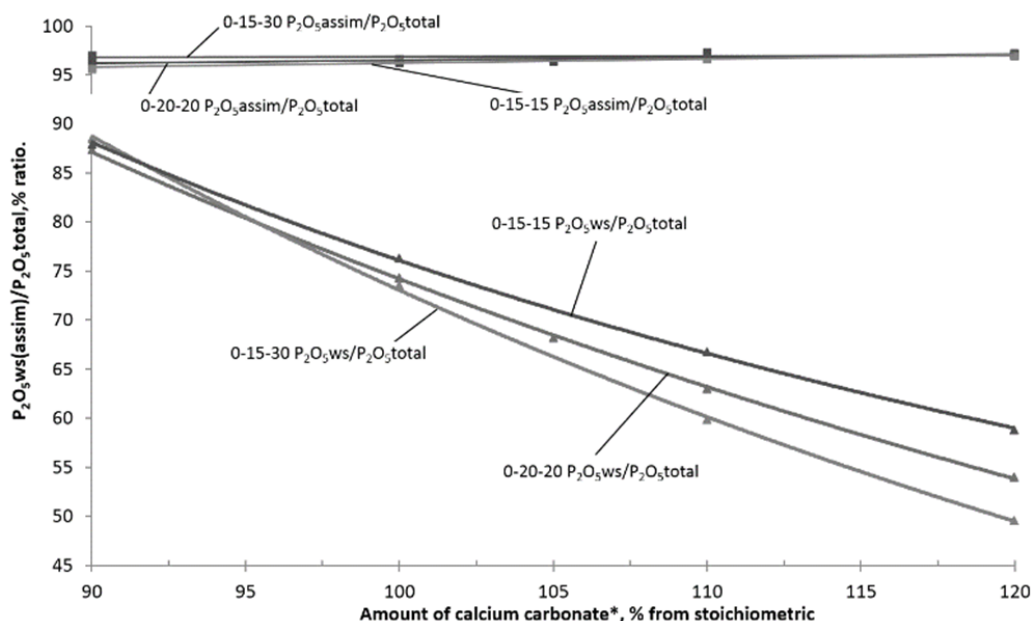

Fig. 4 Dependence of ratios of $P_2O_5_{ws}/P_2O_5_{total}$ & $P_2O_5_{assim}/P_2O_5_{total}$ in PKS-fertilizers of various grades on amount of calcium carbonate supplied for acid neutralization

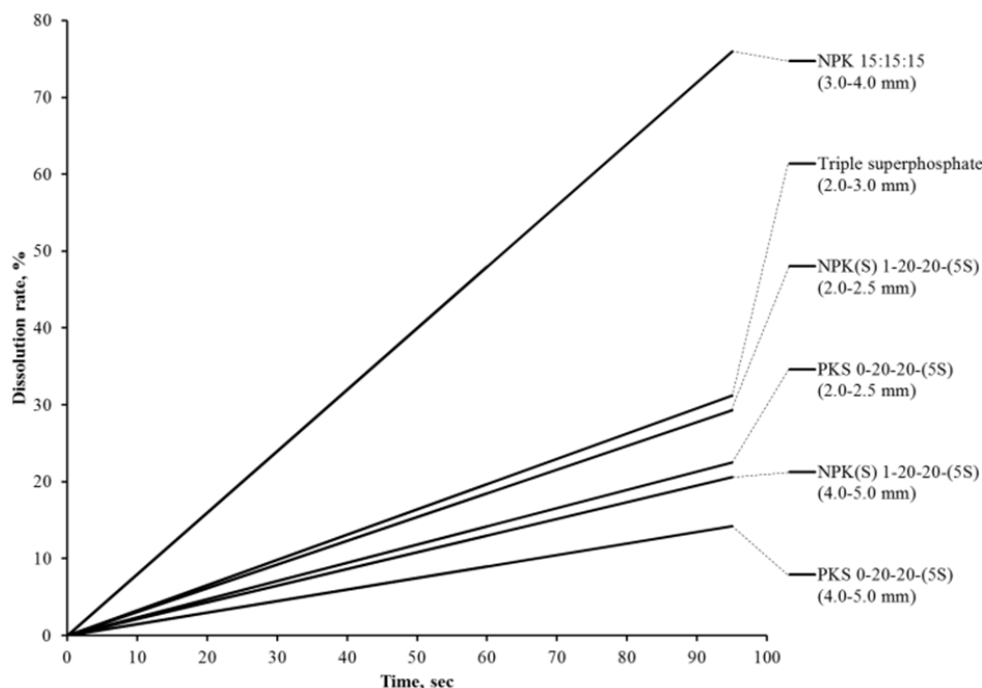

Fig. 5 Characteristic curves of granule dissolution rate in water for PKS- & NPKS-fertilizers of various grades and NPK grade 15:15:15

Introduction of nitrogen into the composition of PKS-fertilizers contributes to an increase in their dissolution rate due to the addition of highly soluble salts to the structure of the granules. For NPKS-fertilizers with nitrogen content of more than 2-3%, almost no slow-release effect is observed, and, in terms of dissolution rate, it tends to be close to the

standard NPK-fertilizer grades.

The innovative flexible technology of PKS-, NPKS-fertilizers protected by three patents of the Russian Federation [2]-[4] was successfully implemented at one of the Russian enterprises in 2014. A pilot industrial plant for fertilizers production of 100 thousand TPA capacity has been installed

and commissioned. Now, the development and modernization of this production plant is ongoing both for capacity and output increase, as well as for the product line expansion. Fig.6 shows the plant.

III. FLEXIBLE TECHNOLOGY BASED ON THE SCHEME WITH AG AND DD

The second area of focus is a flexible intensive energy-saving technology of NP-, NPS-, NPK- and NPKS-fertilizers with the application of a process scheme with an AG and a DD [5]. The technology enables to produce a wide range of different grades including nitrate-containing NPK-fertilizers based on ammonium phosphates, ammonium sulfate, ammonium nitrate and potassium chloride: 12-52-0, 18-46-0, 26-13-0, 16-16-16, 17-17-17, 22-11-11, 20-10-10, 10-20-20, 19-9-19, 27-6-6, 25-9-9, 10-25-25, 10-26-26, 13-19-19, 15-15-

15, 21-6-11, 20-20-14, etc. In Fig. 7, the process flow scheme of NP-, NPS-, NPK- and NPKS-fertilizers production is given.

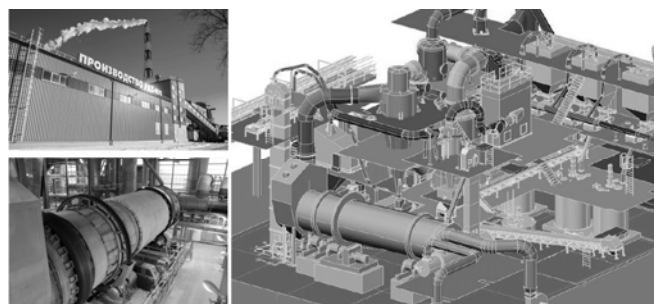

Fig. 6 PKS/NPKS-fertilizers production plant

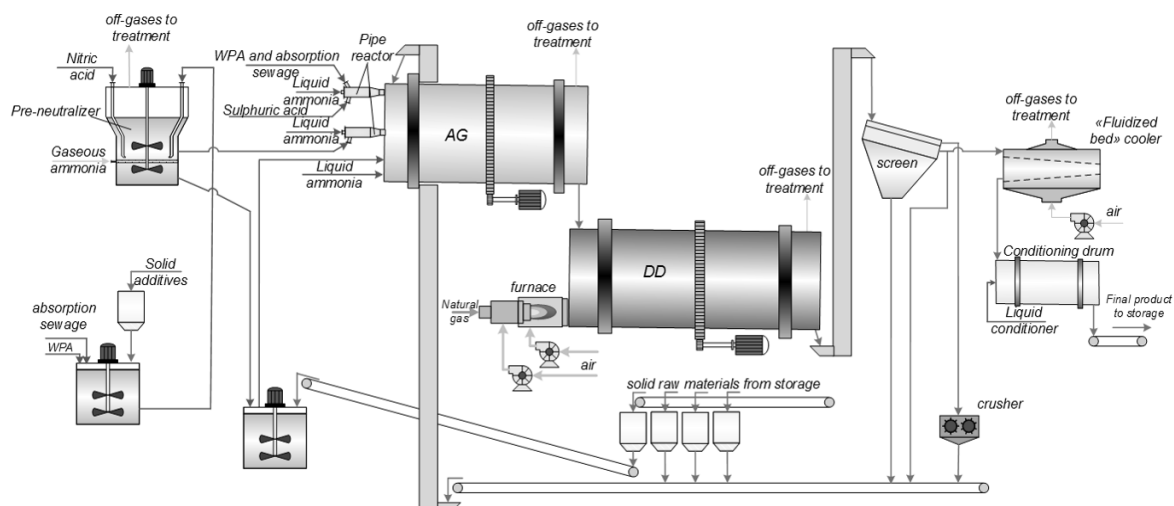

Fig. 7 Process flow scheme of NP-, NPS-, NPK- and NPKS-fertilizers production process

The process of nitrate-containing fertilizers production is based on the joint neutralization of concentrated WPA and nitric acid with ammonia gas in a neutralizer-evaporator vessel and parallel joint neutralization of sulfuric acid, WPA and absorption liquid by liquid ammonia in pipe reactors. The produced partially neutralized slurries are directed to complete neutralization and granulation to AG, and the granules are finally dried in the DD. After drying and screening, the granules of the product fraction are sent for cooling and surface conditioning, and the fine fraction and coarse fraction after grinding are mixed with dry raw components and returned to the AG.

The main advantages of the technology include, but are not limited to:

- 1) The heat of chemical reactions is efficiently used.
- 2) A separate unit for preparation of ammonium nitrate melt is not required.
- 3) The cost of fertilizers drops due to the nitric nitrogen quantity decrease as well.
- 4) This technology improves thermal stability of fertilizers, fire and explosion safety of the process.

- 5) Improved physical and mechanical properties of the products are achieved.
- 6) Sulphur content increases due to replacement of part of ammonium nitrate with ammonium sulfate in the fertilizer, which improves the nutritive value of the fertilizer, see Fig. 8.

Due to an effective utilization of the reaction heat from reactions of the acids neutralization by ammonia, a unit for preparation and concentration of ammonium nitrate melt is excluded from the process scheme. Furthermore, an increased molar ratio of $\text{NH}_3:\text{H}_3\text{PO}_4$ of about 1.6-1.7 is maintained in the product, which enables to reduce the quantity of nitric nitrogen in it. High fire and explosion safety is a significant factor for the production of nitrate-containing NPK-fertilizers [6], [7]. Based on the thermal analysis data, it is found that the presence of diammonium phosphate significantly improves the thermal stability of the product with an increased molar ratio compared to the product with the molar ratio close to 1.0. It is explained by the ability of hydrophosphate ion HPO_4^{2-} to more effectively decrease the concentration of nondissociated nitric acid in comparison with dihydrophosphate ion H_2PO_4^- .

Moreover, an increase in the molar ratio enables to introduce more ammonium sulfate into the product, which also contributes to the improvement of the thermal stability of nitrate-containing NPK-fertilizers. Fig. 9 shows the

dependences of the quantity of released heat and mass loss in the process of ammonium nitrate exothermal decomposition on the molar ratio value.

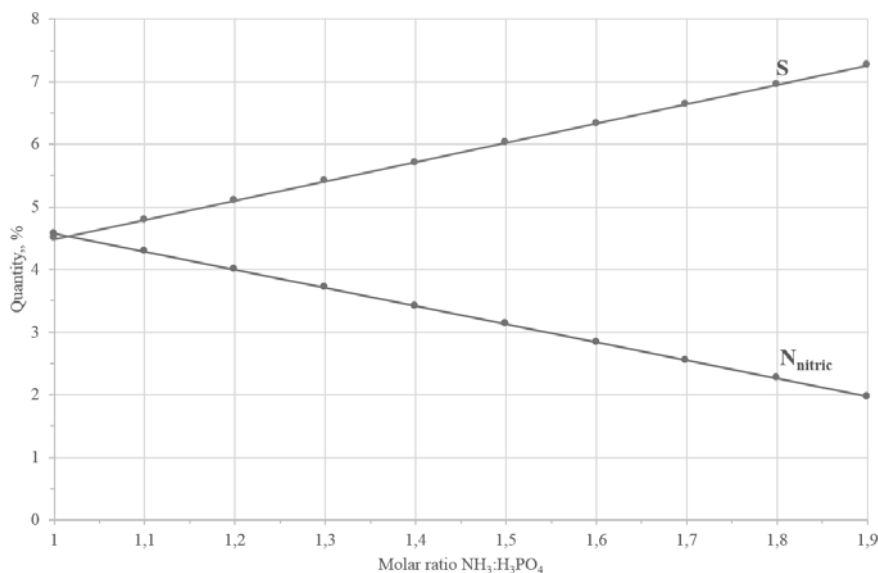

Fig. 8 Influence of the molar ratio $\text{NH}_3:\text{H}_3\text{PO}_4$ on the content of sulfur and nitrate nitrogen in NPK-fertilizers of grade 16-16-16

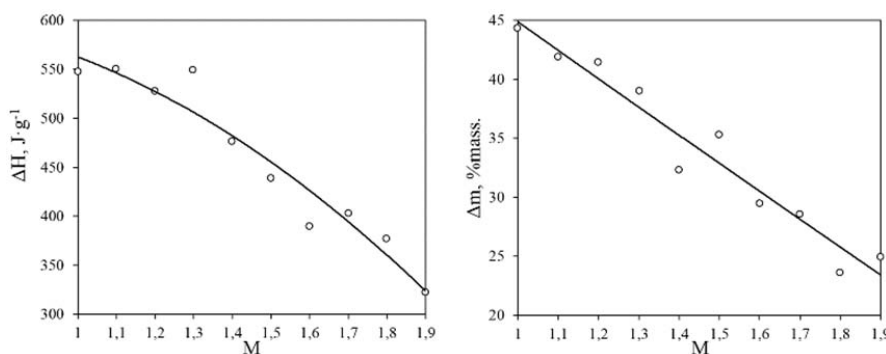

Fig. 9 Dependences of the quantity of released heat and mass loss in the process of ammonium nitrate exothermal decomposition on the molar ratio (M)

TABLE II
RESULTS OF DETERMINATION OF PHYSICAL AND MECHANICAL PROPERTIES
OF COMPLEX NITRATE-CONTAINING FERTILIZERS

Fertilizer Grade	Molar Ratio (MO)	Properties		
		σ , kPa	P, MPa	K, $\text{mmol} \cdot \text{g}^{-1} \cdot \text{hour}^{-1}$
16:16:16	1.07	312	5.1	3.51
	1.65	176	5.0	3.04
22:11:11	1.04	412	4.4	4.96
	1.71	354	3.2	4.04
20:10:10	1.03	385	3.8	4.06
	1.70	297	2.4	3.74
19:9:19	1.03	336	4.4	3.96
	1.67	259	3.3	3.22
27:6:6	1.05	435	4.9	5.16
	1.66	391	3.9	5.00
26:13:0	1.06	447	5.3	5.32
	1.68	300	2.4	3.21

σ – caking, P – static strength of granules, K – hygroscopicity coefficient.

The laboratory studies also proved that products with a high molar ratio have better physical and mechanical properties than similar grades produced, when the molar ratio is close to 1.0 [8]. Table II gives the results of measurements and determination of physical and mechanical properties of complex nitrate-containing fertilizers.

Fig. 10 demonstrates the characteristic curves of the granules static strength and caking of nitrate-containing NPK-fertilizers samples of grade 17:17:17 dependence on the degree of phosphoric acid neutralization expressed by molar ratio $\text{NH}_3:\text{H}_3\text{PO}_4$.

Based on the data in Fig. 10, it is possible to find optimum values, in terms of fertilizers quality parameters, of the phosphoric acid neutralization degree (molar ratio) for nitrate-containing NPK-fertilizers with the nutrients ratio $\text{N}:\text{P}_2\text{O}_5:\text{K}_2\text{O} = 1:1:1$ (in this case 17:17:17). The lowest tendency to caking and the highest value of granules static strength are observed

in case of the products that are produced with the molar ratio close to 1.3 and 1.6. This is explained by the influence of various factors, including chemical composition of fertilizers, generation of double salts and solid solutions, structure of the formed granules, presence of impurities compounds with fluorine, iron, aluminium, calcium, etc., which can generate various complex salts depending on the degree of WPA neutralization. Combination and overlapping of all these

factors determine polyextremal type of the dependence of fertilizers properties on the molar ratio. Thus, taking into account the thermal stability increase, nitrate nitrogen content decrease, and, consequently, fertilizers' cost reduction, sulfur content increase, the most preferable and beneficial option is an option with the molar ratio equal to 1.6. A more detailed consideration to this issue will be given in another paper.

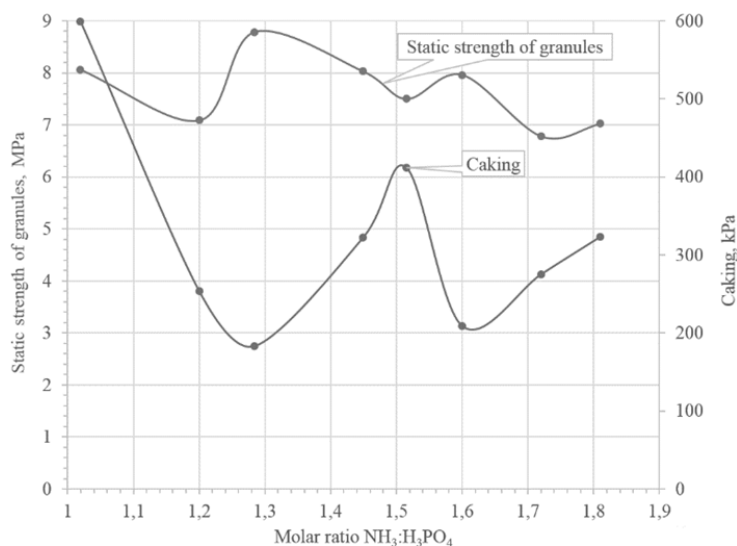

Fig. 10 Dependences of the granules static strength and caking of nitrate-containing NPK-fertilizers samples of grade 17:17:17 on the degree of phosphoric acid neutralization expressed by molar ratio $\text{NH}_3:\text{H}_3\text{PO}_4$

An increase of the molar ratio causes a decrease in the specific consumption of nitric acid, and the efficient utilization of the heat of the reactions enables to apply nitric acid in a nonconcentrated form. All that leads to the reduction of nitrate-containing NPK-fertilizers costs. Now, this technology is under implementation at one of the Russian enterprises.

REFERENCES

- [1] A. Norov, A. Malyavin, D. Pagaleshkin, Application of units, combining the granulation and drying, for development of flexible processes of phosphorous-containing fertilizers production, "SYMPHOS 2017", 4th International Symposium on Innovation and Technology in the Phosphate Industry.
- [2] Patent of the Russian Federation No. RU2514306C1. Method of production of phosphorus-potassium granulated fertilizer, Yu. D. Chernenko, A. M. Norov, K. N. Ovchinnikova, A. S. Malyavin, D. A. Pagaleshkin, G. S. Razmakhnina, P. S. Fedotov, R. T. Usmanov, V. N. Tereshenkov, M. I. Rezenkov, V. V. Afanasyev, I. A. Petropavlovskiy, published on 27.04.2014.
- [3] Patent of the Russian Federation No. RU2551541C1. Method of production of complex fertilizer, B. V. Levin, A. M. Norov, K. N. Ovchinnikova, A. S. Malyavin, D. A. Pagaleshkin, P. S. Fedotov, R. T. Usmanov, V. N. Tereshenkov, M. I. Rezenkov, V. V. Afanasyev, I. A. Petropavlovskiy, published on 27.05.2015.
- [4] Patent of the Russian Federation No. RU2607332C2. Method of production of complex fertilizer, B. V. Levin, A. M. Norov, K. N. Ovchinnikova, A. S. Malyavin, P. S. Fedotov, A. V. Sidelnikov, I. G. Pukhov, V. V. Afanasyev, published on 10.01.2017.
- [5] Patent of the Russian Federation No. RU2541641C1. Method of production of complex fertilizer, B. V. Levin, A. M. Norov, D. A. Pagaleshkin, A. S. Malyavin, K. G. Gorbovskiy, V. M. Kolpakov, A. I. Mikhaylichenko, I. A. Kaleev, O. L. Glagolev, A. V. Shibnev, published on 20.02.2015.
- [6] K. G. Gorbovskiy, M. P. Lobacheva, I. M. Kochetova, A. M. Norov, A. S. Malyavin, A. I. Mikhaylichenko. Influence of Ammonium Nitrate on the Thermal Decomposition of Complex Nitrogen-Phosphorus-Potassium Fertilizers. Theoretical Foundation of Chemical Engineering, 2016, Vol. 50, No. 5, pp. 798-805.
- [7] K. G. Gorbovskiy, A. I. Kazakov, A. M. Norov, D. A. Pagaleshkin, A. I. Mikhaylichenko. Thermal Decomposition Study of Chloride-Containing Complex Ammonium Nitrate-Based Fertilizers by Thermogravimetry and Differential Scanning Calorimetry. Russian Journal of Applied Chemistry, 2016, Vol. 89, No. 9, pp. 1383-1392.
- [8] K. Gorbovskiy, A. Kazakov, A. Norov, A. Malyavin, A. Mikhaylichenko. Properties of Complex Ammonium Nitrate-Based Fertilizers Depending on the Degree of Phosphoric Acid Ammoniation. International Journal of Industrial Chemistry, 2017, Vol. 8, Is. 3, pp. 315-327.