

Comprehensive Studies on the Aerodynamic Characteristics of Subsonic Scarf Inlets

M. Jegannath, V. Akshaya, B. Arunkumar, G. Lakshmi Soundharya, V. Thenmozhi, S. Varun, V. R. S. Kumar

Abstract—For scarf inlet design, the primary variable of interest is the circumferential extent over which the extended lower lip is formed. In this paper, an attempt has been made to optimize the aerodynamic shape of a subsonic scarf inlet with aerodynamically shaped center-body with a particular value of the circumferential extent. The parametric analytical studies have been carried out using a Spalart-Allmaras turbulence model. From our preliminary studies, we concluded that for a particular value of circumferential extent, there will be an exact shape of the center-body with certain geometric orientation for the existence of an aerodynamically efficient scarf inlet for modern aircraft engines. This numerical study is a pointer towards for the design optimization of scarf inlets for modern aircraft engines.

Keywords—Aerodynamics of scarf inlets, inlet design, modern aircraft inlets, subsonic scarf inlet.

I. INTRODUCTION

SCARF inlet design received considerable attention in the aircraft industry due to its predominant aerodynamic shaped design providing a desirable inlet characteristics of an aircraft compared with the other conventional inlets by offering a better pressure recovery [1]. The scarf unit is an inlet design where the lower lip extends forward of the upper lip [4]. The magnitude of this forward extension of the lower lip is characterized by the scarf angle, γ , [13] which is the angle difference between the planar hille of a conventionally designed inlet and the planar hilit of the scarf inlet [5]. The scarf aero-intake has a constant scarf angle along the circumferential direction (transition angle is 180° ; here the transition angle is defined as a circumferential angle of the region where the scarf angle is not zero), while the scoop aero-intake has an inconstant scarf angle (transition angle is less than 180°) [11]. Note that the extension of the lower-lip of the scarf inlet with cowl shape helps us to prevent from devour the unwanted contaminants while grounding and noise gets

M. Jegannath is Research Trainee, Department of Aeronautical Engineering, Kumaraguru College of Technology (Affiliated to Anna University Chennai) Coimbatore – 641 049, Tamil Nadu, India (phone: +91-9655272204, e-mail: jeganmmm@gmail.com).

V. Akshaya, G. Soundharya Lakshmi, V. Thenmozhi and S. Varun are Undergraduate Students, Department of Aeronautical Engineering, Kumaraguru College of Technology (Affiliated to Anna University Chennai) Coimbatore – 641 049, Tamil Nadu, India (e-mail: akshaya.7896@gmail.com, soundharyagunasek@gmail.com, then8.26.98@gmail.com, varunshanmugamkl@gmail.com).

Arunkumar B is working at TATA Advanced Systems, Hyderabad, India (phone: +91-7708884179; e-mail: pkbarun0496@gmail.com).

V. R. S. Kumar is Professor and Aerospace Scientist (ISRO), currently with Aeronautical Engineering Department, Kumaraguru College of Technology, Coimbatore – 641 049, affiliated to Anna University, Tamil Nadu, India (phone: +91-8754200501; e-mail: vr_sanalkumar@yahoo.co.in).

reduced [6]. A scarf inlet is characterized by having a longer lower lip than upper lip leading to both aerodynamic and acoustic advantages [3]. Aerodynamically, a scarf inlet has higher angle of attack capability and is less likely to ingest foreign objects while the aircraft is on the ground [10].

Most modern passenger and military aircraft jet engines have an inlet to bring free stream air into the engine [2]. The pressure recovery of the inlet depends on a wide variety of factors, including the shape of the inlet [12], the speed of the aircraft, the airflow demands of the engine, and aircraft maneuvers [7]. These are succinctly reported by NASA. In this paper, we are focusing on the shape of the spinner, which is the center-body of the inlet [9].

Although many studies have been reported on the aerodynamic characteristics of subsonic scarf inlets, the geometry design optimization of the spinner for such inlets is still an active design objective for modern aircraft engines [8]. In this paper, parametric analytical studies have been carried out to optimize the scarf inlet with a special attention on the aerodynamic design of the center-body with a particular value of the circumferential extent, which are discussed in the subsequent sections.

II. NUMERICAL METHOD OF SOLUTION

The numerical simulations have been carried out with the help of density based Spalart-Allmaras turbulence model in two-dimensional steady case. The model uses a control volume based technique. The grids are clustered near the solid walls using a suitable stretching function. A typical grid system in the computational domain is selected after a detailed grid refinement exercise. Ideal gas is used as a working fluid and the viscosity is computed based on Sutherland formula. The geometric variables and material properties are known *a priori*. Initial wall temperature, inlet total pressure, and Mach number are specified. At the solid walls a no slip boundary condition is imposed. Fig. 1 shows the physical models of a scarf inlet with different spinner shapes, viz., Bell shaped, Dual bell, curvilinear triangle with cavity and Curvilinear triangle. The scarf inlet is fixed inside a domain of size 240 x 140 mm. In all the cases inlet Mach number is given as 0.5.

In this paper, a scarf inlet with different geometrical shapes of spinners is numerically simulated, and the results are discussed in detail in the subsequent section. Fig. 2 shows the grid system in the computational domain of the scarf inlet with exterior domain. In all the cases, the shape and the size of the outer cowl is kept as the same, and various center-body shapes are considered for the design optimization of a scarf inlet.

III. RESULTS AND DISCUSSION

In this paper, the comprehensive numerical studies are carried out to find out an appropriate geometrical design for a spinner in a scarf inlet so as to enhance the pressure recovery by reducing the total pressure loss. In our numerical study, we have chosen four different spinner shapes and the ratio of the static and total pressures are compared at the starting and the end of the spinner design. The comparisons of the static and total pressures for different shapes are shown in Figs. 3-6.

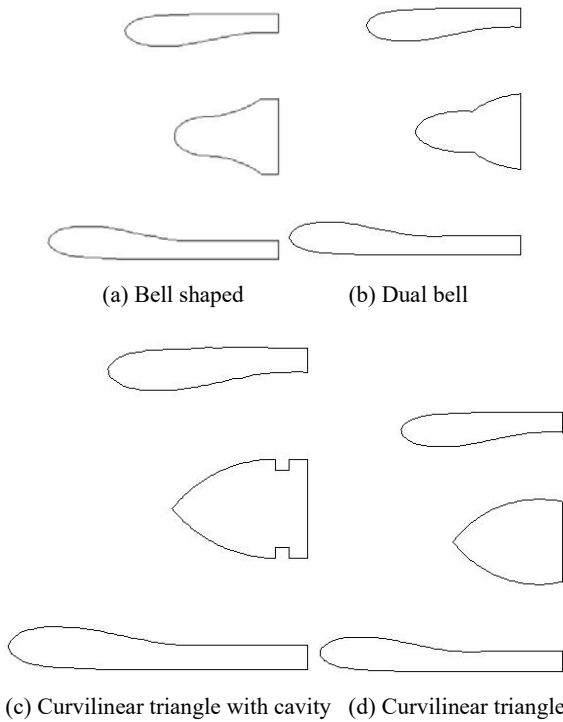

Fig. 1 (a)-(d) Physical models of a scarf inlet with different spinner shapes

The differences in the variation of total pressure and static pressure at the starting and the end of the spinners are clearly seen in these charts. The comparisons of the total pressure ratios (P_{t2}/P_{t1}) and the static pressure ratios (P_2/P_1) for cases with four different spinner shapes are shown in Table I. It is seen from Table I that the total pressure recovery is maximum for a spinner with curvilinear triangle shape. The dual bell shaped spinner is having maximum static pressure ratio with considerable amount of total pressure recovery. The bell shaped spinner is having the lesser total pressure recovery and minimum static pressure ratio. Hence, curvilinear triangle shaped spinner is the best spinner shape for the scarf inlet considered in our study as it is having minimum pressure loss than all the other cases considered in our study.

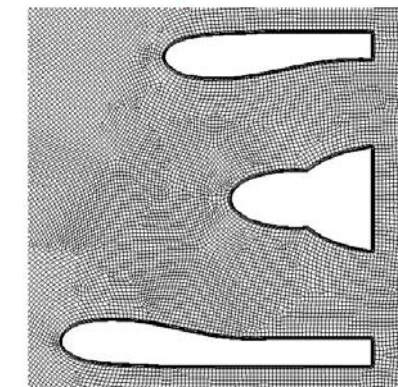
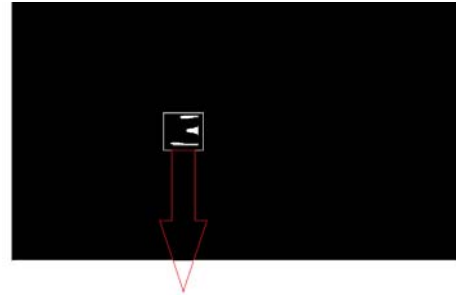
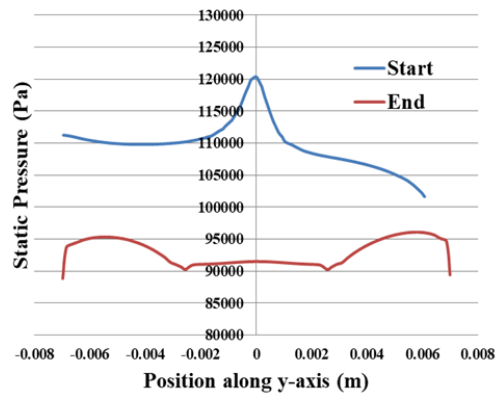
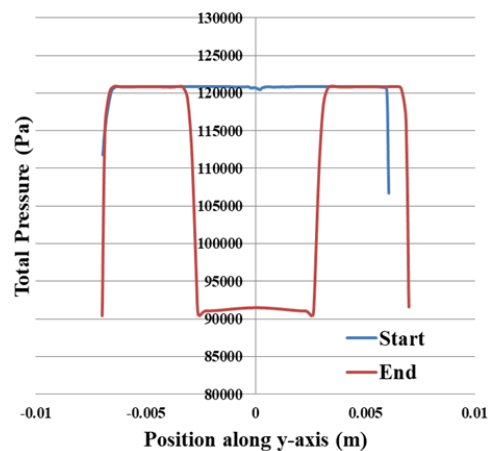

Fig. 2 Grid system in the computational domain



(a) Static Pressure



(b) Total Pressure

Fig. 3 (a), (b) Comparison of Static and Total pressures at the starting and the end of the Bell shaped spinner

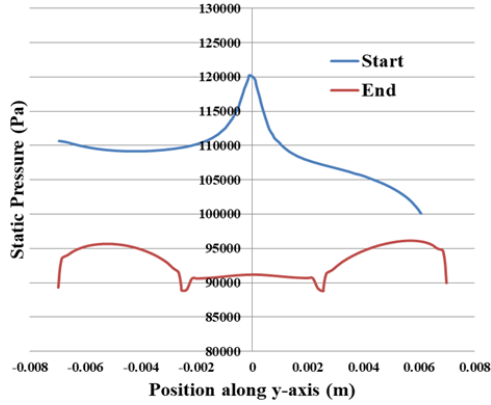

(a) Static Pressure

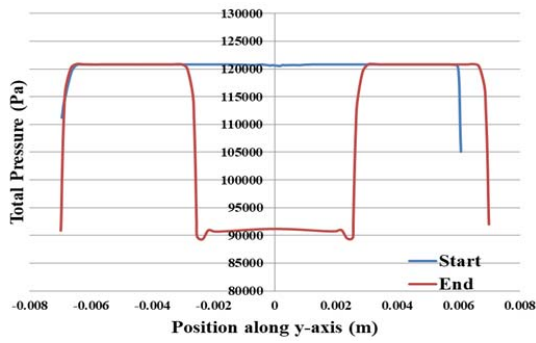

(b) Total Pressure

Fig. 4 (a), (b) Comparison of Static and Total pressures at the starting and the end of the Dual bell shaped spinner

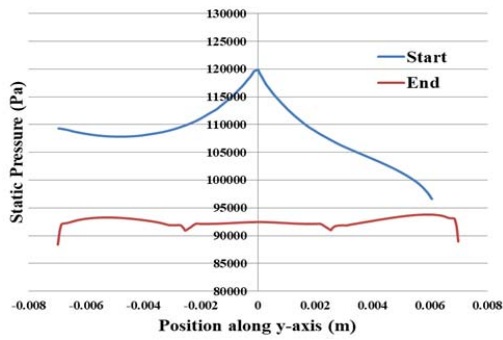

(a) Static Pressure

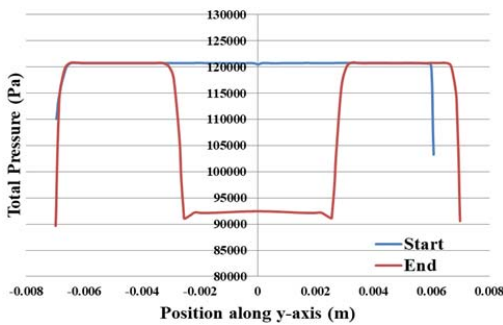

(b) Total Pressure

Fig. 5 (a), (b) Comparison of Static and Total pressures at the starting and the end of the curvilinear triangle with cavity shaped spinner

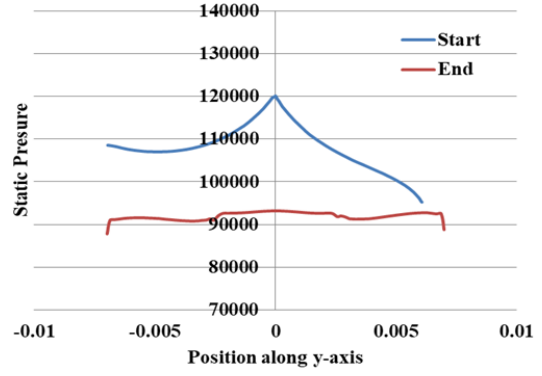

(a) Static Pressure

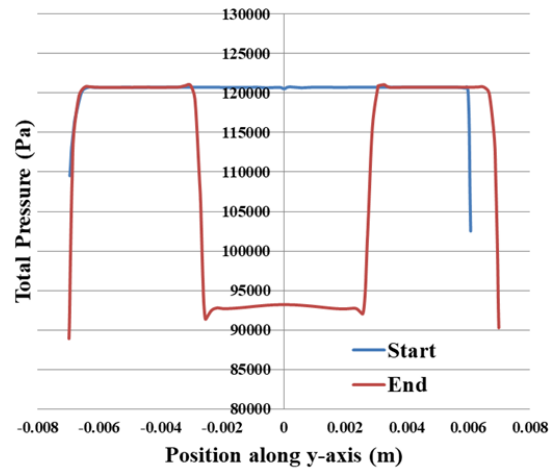

(b) Total Pressure

Fig. 6 (a), (b) Comparison of Static and Total pressures at the starting and the end of the curvilinear triangle shaped spinner

TABLE I
 COMPARISON OF PRESSURE RATIOS

Spinner Shape	Total Pressure Recovery (P_t/P_{t1})	Static Pressure Ratio (P_2/P_1)
Bell	0.883625	0.839435
Dual Bell	0.899502	0.847842
Curvilinear triangle with cavity	0.895439	0.842086
Curvilinear triangle	0.902559	0.841418

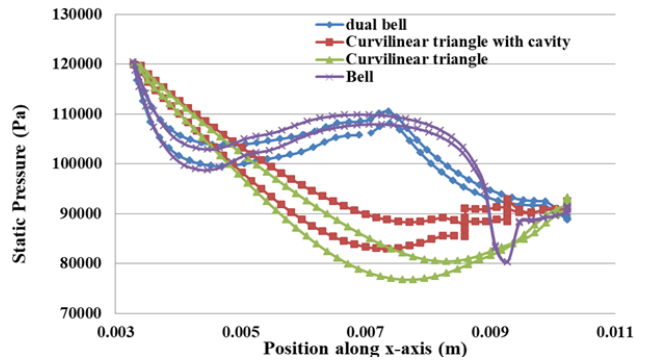

Fig. 7 Comparison of the static pressure over the surface of the spinner of different shapes

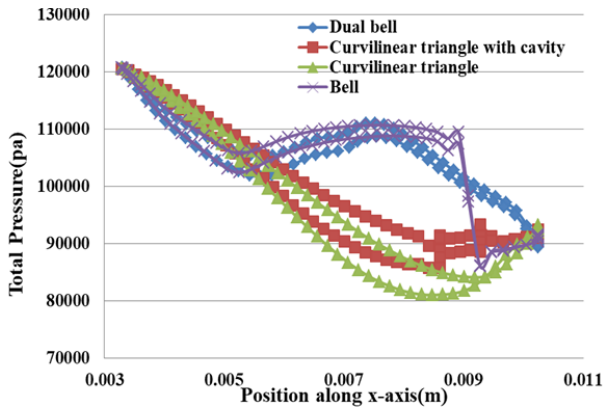
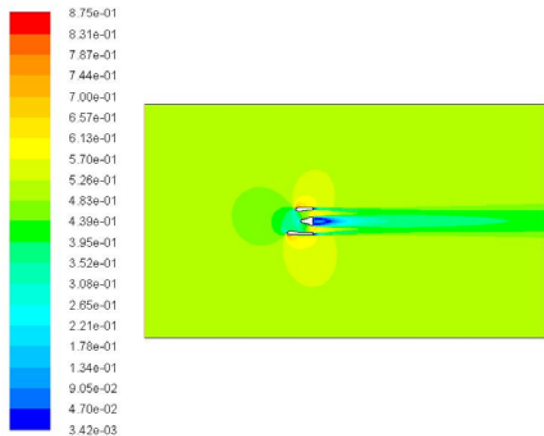
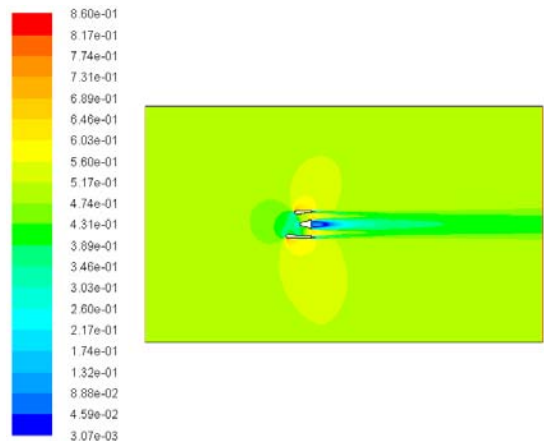

Fig. 8 Comparison of the total pressure over the surface of the spinner of different shapes

The comparison of the static and total pressures over the surface of the spinners of different shapes are shown in Figs. 7 and 8. It is seen from these charts that although the static and total pressure is lesser over the surface for the curvilinear triangle shaped spinner, it is maximum at the end of the spinner. Hence, the total pressure recovery is maximum for the curvilinear shaped spinner when compared with all the other cases.



(a) Bell Shaped



(b) Dual bell

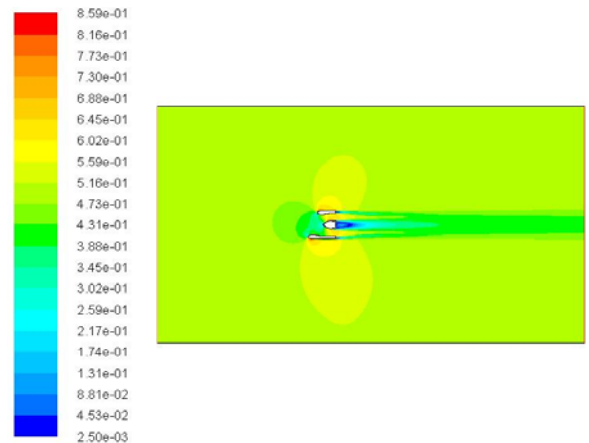

(c) Curvilinear triangle with cavity

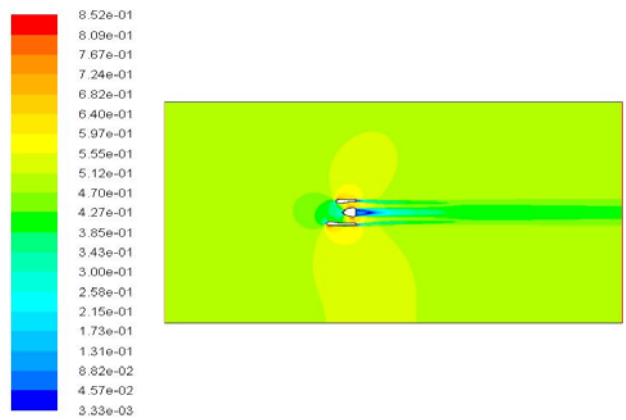

(d) Curvilinear triangle

Fig. 9 (a)-(d) Mach number contours of a scarf inlet with different spinner shapes

IV. CONCLUSION

The results from the parametric studies of the case on hand reveal that the spinner shape is having more bearing on the total pressure recovery in a scarf inlet. In this paper, the numerical studies are carried out using a 2D, steady, density based, and Spalart-Allmaras turbulence model. From our numerical study, we conjectured that the curvilinear triangle shaped spinner is providing better total pressure recovery than all the other cases considered herein. Although the static and the total pressure values over the surface of the curvilinear triangle shaped spinner are lesser than the other spinner shapes, it is providing higher values at the end of the spinner surface. This study will help the designer for deciding the best aerodynamic shape of scarf inlet for modern aircraft engines through numerical exercises lucratively.

ACKNOWLEDGMENT

The authors would like to thank the management of Kumaraguru College of Technology, Coimbatore – 641 049, Tamil Nadu, India for their extensive support of this research work.

REFERENCES

- [1] John M. Abbott, "Computational Study of the Aerodynamic Performance of Subsonic Scarf Inlets". 40th AIAA/ASME/SAE/ASEE Joint Propulsion Conference and Exhibit 11 - 14 July 2004, Fort Lauderdale, Florida.
- [2] Abbott, J. M., Dietrich, D. A., "Aerodynamic and Directional Acoustic Performance of a Scoop Inlet", NASA TP-1028, September, 1977.
- [3] Abbott, J. M., "Aerodynamic Performance of Scarf Inlets", AIAA Paper 79-0380, January, 1979.
- [4] Abbott, J. M., and Slater, John W., "Computational Study of the Aerodynamic Performance of Three-Dimensional Subsonic Inlets", AIAA Paper 2001-3886, July 2001.
- [5] T. S. Crum, D. E. Yates, T. L. Andrew and N. O. Stockman., "Low Speed Test Results Of Subsonic, Turbofan Scarf Inlets". AIAA/SAE/ASME/ASEE 29th Joint Propulsion Conference and Exhibit June 28-30, 1993 / Monterey, CA.
- [6] Abbott, J. M., "Aero acoustic Performance of a Scoop Inlet", AIAA Paper 77-1354, October, 1977.
- [7] Brent, A, Miller and John M., "Aerodynamic and acoustic Performance of two choked-flow Inlets under static conditions" National Aeronautics and Space Administration. Washington, D.C. September 1972.
- [8] Brent A, Miller, "Experimentally Determined Aero acoustic Performance and Control of Several Sonic Inlets," AIAA Paper 75-1184, Anaheim, Calif., 1975.
- [9] James A. Albers, Norbert O. Stockman, and John J. Hirn, "Aerodynamic Analysis of Several High Throat Mach Number Inlets For The Quiet Clean Short-Haul Experimental Engine". National Aeronautics and Space Administration. Washington, D. C. January 1975.
- [10] Howard L, Wesoky, John M. Abbott, James A. Albers, and Donald A. Dietrich., "Low-Speed Wind Tunnel Tests of a 50.8-Centimeter (20-IN) 1.15-Pressure-Ratio Fan Engine Model". National Aeronautics and Space Administration. Washington, D. C. June 1974.
- [11] James A. Albers, "Theoretical and Experimental Characteristics of A 13.97- Centimeter-Diameter Inlet at STOL Takeoff and Approach Conditions". National Aeronautics and Space Administration. Washington, D.C. June 1973.
- [12] Karen A. Deere, Bobby L. Berrier, Jeffrey D. Flamm, Stuart K. Johnson, "Computational study of fluidic thrust vectoring using separation control in a nozzle," 21st Applied Aerodynamics Conference 23-26 June 2003, Orlando, Florida, AIAA 2003-3803.
- [13] Yonghwan Park, Sungtae Kim, Soogab Lee, Cheolung Cheong, "Numerical investigation on radiation characteristics of discrete-frequency noise from scarf and scoop aero-intakes", Applied Acoustics 69 (2008) 1258-1269.