

Current Status and Future Trends of Mechanized Fruit Thinning Devices and Sensor Technology

Marco Lopes, Pedro D. Gaspar, Maria P. Simões

Abstract—This paper reviews the different concepts that have been investigated concerning the mechanization of fruit thinning as well as multiple working principles and solutions that have been developed for feature extraction of horticultural products, both in the field and industrial environments. The research should be committed towards selective methods, which inevitably need to incorporate some kinds of sensor technology. Computer vision often comes out as an obvious solution for unstructured detection problems, although leaves despite the chosen point of view frequently occlude fruits. Further research on non-traditional sensors that are capable of object differentiation is needed. Ultrasonic and Near Infrared (NIR) technologies have been investigated for applications related to horticultural produce and show a potential to satisfy this need while simultaneously providing spatial information as time of flight sensors. Light Detection and Ranging (LIDAR) technology also shows a huge potential but it implies much greater costs and the related equipment is usually much larger, making it less suitable for portable devices, which may serve a purpose on smaller unstructured orchards. Portable devices may serve a purpose on these types of orchards. In what concerns sensor methods, on-tree fruit detection, major challenge is to overcome the problem of fruits' occlusion by leaves and branches. Hence, nontraditional sensors capable of providing some type of differentiation should be investigated.

Keywords—Fruit thinning, horticultural field, portable devices, sensor technologies.

I. INTRODUCTION

FOOD, despite its degree of processing, will always be dependent on agricultural practices. Fruits and vegetables, due to their fiber and vitamin content, have been increasingly praised. Fruits in particular have been playing an important role against obesity, which is now a major health problem in Europe, with more than 50% of facing this problem [1]. Vegetable and fruit production, and an increase of the corresponding economical results, are directly correlated to an in-depth technical knowledge, innovation, the adoption of new production methodologies and produce valorization. The adoption of new production methodologies aims getting a sustainable use and monetization of the production factors,

M. Lopes is with the University of Beira Interior, Rua Marquês d'Ávila e Bolama, 6201-001, Covilhã, Portugal (e-mail: lopes.masl@gmail.com).

P. D. Gaspar is with the University of Beira Interior, Rua Marquês d'Ávila e Bolama, 6201-001, Covilhã, Portugal and C-MAST - Centre for Mechanical and Aerospace Science and Technologies (corresponding author: (+351)275329759; e-mail: dinis@ubi.pt).

F. C. Santos is with the University of Beira Interior, Rua Marquês d'Ávila e Bolama, 6201-001, Covilhã, Portugal and C-MAST - Centre for Mechanical and Aerospace Science and Technologies (e-mail: bigares@ubi.pt).

M. P. Simões is with the Agriculture School, Polytechnic Institute of Castelo Branco, Quinta da Senhora de Mércules, Apartado 119, 6001-909 Castelo Branco (e-mail: mpaulasimoes@ipcb.pt).

without ever despising the production growth and produce valorization. The produce valorization can be achieved either by improving the commercial chain, through transformation or promotion of the produce. The quality of fruit is dependent on the overall fruit tree's crop load, given that grade, the most impactful quality parameter over fruit economic value, is also the most intimately related to the trees' crop load adjustment. If pruning was not too intensive, in order to guarantee a greater crop yield, and the fruit to flower ratio turns out to be high, as consequence of favorable climate conditions, it will result in an excessive crop load adjustment. In this case, producers have no other choice than proceeding to perform some kind of load adjustment, i.e. to practice fruit thinning. Hand thinning is the most commonly used method, although it requires a great availability of work force, which often presents itself as a limiting factor, since it is a lengthy process it can become quite costly. Chemical thinning is not a common practice in trees like peach tree because it has shown inconsistent results and it presents environmental concerns. Automated thinning is a potential solution for significantly decreasing labor-costs and the time consumed by thinning operations. Particularly, the use of electronic sensors along with fruit or blossom removal mechanisms, could result in devices operating with a closed-loop control strategy, capable of identifying and locating their target, which is the most obvious and reliable (although not easily achievable) way of providing the necessary selectivity, predictability and the ability to deterministically optimize performance and consequent results, which are necessary for a wide adoption of these systems.

II. MECHANICAL THINNING

A. Trunk and Limb Shakers

The first mechanized thinning experiments involved the use of trunk shakers, having resulted in very similar results to those obtained with manual thinning, regarding yield and grade of the fruits, without inducing significant damage to the trees. The trials were executed on 13 different parcels and 17 cultivars, although no economical results were presented [2].

A two-year comparative study realized trials with trunk shakers, manual thinning, bat thinning and a combination of the first method with a follow-up manual thinning. The trunk shaker with a manual follow-up thinning showed up the best results, with a time reduction of about 57% and a cost reduction of 88%, when compared to the traditional manual thinning. Although the fruits turned out to reach acceptable grades, this method removed an extra 30% more fruits than manual thinning, which in turn resulted in a decreased crop

yield and profit per tree [3]. More recent studies using branch shakers showed that the combination of mechanized thinning along with the manual method could reduce the time required to execute the task by 30% to 41%. Despite this reduction, the used equipment showed clear disadvantages, like an excessive removal of fruitlets, decreasing the amount of fruits that reached a marketable grade by 6%, an irregular thinning pattern, being especially intense near the treetop and the fact that the largest fruitlets have a greater tendency to be removed due to the also greater generated moment resulting from the shaking action, an inability to remove fruitlet clusters [4] and even a significant removal of leaves, up to negatively affecting the fruit growth [5], [6]. A novel branch shaker was presented and tested by [5], which made use of a lower vibration frequency and did not exert a clamping force on the branches. Hence, it avoided causing damage by the resulting torsion strains. This system tried to avoid the disadvantages associated with the mechanical vibrations and to facilitate the progression towards the automation of these operations. It consisted of a linear actuator with a “U” shaped end-effector, mounted upon a vehicle containing a hinged arm (see Fig. 1). The authors of this work focused on trying to find out which mechanical phenomenon led to the removal of the fruits, depending on their sizes, positioning in the tree, types of branches and their natural frequencies, in order to improve the fruit distribution and explain experimental results, through the execution of a modal analysis using computational simulation software. A high-speed video analysis was also carried out, as an attempt to relate fruit vibration frequency while the limbs were shaken, with the acceleration at detachment, but it did not present any obvious correlation. Despite its promising nature, the use of this device without any complementary process resulted in an excessive removal of fruits, particularly the ones near the treetop, which is inconvenient since these fruits have a greater chance to thrive due to a greater sun exposure. Although the study confirmed that the number of removed fruits could be estimated by the analysis of the natural frequency of the branches, which tends to increase with height.



Fig. 1 Limb shaker without a mechanical coupling to the branches [6]

Another principle that could be applied to fruit thinning is the use of vertical flexible elements, made of rubber or rope, mounted on a structure on a tractor. These elements could be dragged over the trees causing some of the fruits to fall. This method has been previously used for flower thinning for the first time [7], it has the potential to avoid the excessive

removal of fruits, the most evident disadvantage observed in vibratory devices. One example of this type of device is Phil Brown, a peach blossom thinner, which comprises of a curtain of flexible ropes coupled to a central axis, which is moved by a motor, as show in Fig. 2. No studies were found regarding its application to fruit thinning.



Fig. 2 Peach blossom thinning device, Phil Brown [8]

B. Tractor Coupled Devices

Drum-shakers have also been used for fruit thinning, removing the fruits through the exertion of an impact force rather than through vibration alone. A study compared the use of a trunk shaker and a spiked drum shaker developed by the United States Department of Agriculture (USDA), on “Y” trained peach trees. It was concluded that the drum-shaker might be a better thinning tool because it transferred less energy and did not clamp the tree as the trunk shaker did. The yield did not change significantly across the different methods [9], and no economical results were provided. Another study involved the use of two devices on peach trees, Darwin 300 from the German company Fruit-tec and the same drum-shaker mentioned above, developed by the USDA. The first one comprehends a structure coupled to a tractor, comprising of a 3-m vertical shaft with rotating flexible strings and was used for blossom thinning (see Fig. 3 (a)). It was originally designed for apple trees. The second was used for fruit thinning and comprises a drum, which was coupled to a tractor, with seven sets of nylon stems also radially disposed along a shaft (Fig. 3 (b)). This shaft could be set to spin freely or to exert a resistant force, derived from the tractor’s hydraulic system. Additionally, the shaft could be set to execute a frequency-regulated vibration along the horizontal plane, so that the stems could better penetrate into the tree line.

The use of this equipment in “V” shape system trained peach trees, followed by complementary manual thinning resulted in a decrease of crop load by 58% and an increase in fruit size by 9%, when compared to the manual methods. The time required to execute the operations was reduced from 54% up to 81%. Although the authors advise that since there is a risk of over thinning, even though the machinery can be regulated, mechanized thinning should not replace manual thinning completely. In addition, it was remarked that these methods are nonselective and in fact, larger fruits tend to be more frequently removed than the smaller ones, additionally

they can cause significant damage to the trees. Although, some trials did show economic positive impact (175\$/ha up to 1966\$/ha) when compared to hand thinning alone. These values were only presented in respect to one of the four trials. The authors suggested that further studies are needed to understand how to better control the final crop load, by optimizing the tractor's and equipment's speed, and that tree training systems should also be investigated as a means to facilitate an optimal operation of the drum shaker [10]. In the following years, the same authors realized some trials using the same equipment but with the drum positioned horizontally and having an adjustable angle, which tended to remove more flower and enabled more adaptability to different tree forms. The economic impact was positive in most trials [11].



(a) Darwin 300, blossom thinner with flexible stems [12]



(b) USDA drum-shaker, fruit thinner [13]

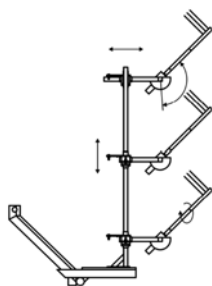

(c) Multiple rotor blossom thinner

Fig. 3 Tractor coupled blossom and fruit thinning equipment

Dise [14] presented an automated hydraulic string thinner positioning system which comprehended, a lateral offset cylinder, a tilt cylinder, proportional control valves and a flow divider and an interface comprehending an emergency stop button, a joystick for manual control of the cylinders, a switch

to alternate between manual and automated modes and a start stop button. The manual control could be performed in a walk-behind mode where a person would carry the manual control interface adjusting the thinner's angle while walking behind the tractor and the driver focused on following a straight pathway. The automatic mode used ultrasonic sensors position along a mast, to detect the canopies and regulate the thinner's drum axis so that it kept parallel to the "V" of the trained trees. The tractor also carried a laser range finder a GPS module, in order to perform a 3D mapping of the orchards and serve the same purpose of the ultrasonic sensors, this last line of work relates to [15], described in greater detail in Section 3.2.5 of this review.

Training systems have shown to optimize results for blossom thinning obtained with Darwin [16], although the actuation over an optimal time window has proven to have a greater correlation with the results [17].

A two-year study also involving the Darwin blossom thinner and two modified versions of the USDA drum-shaker, wherein a version one of the drums was removed and in the second version it was additionally scaled down for improved maneuverability. This study has confirmed that over thinning is indeed an issue when this technological solution is used. One of the five trials had no data regarding yield and another trial had no control (hand thinning) to enable any valuable comparison. Out of the remaining three trials, hand thinning alone consistently resulted in a higher total yield and in only one instance of one trial did the utilization of mechanized methods presented a higher yield of high market value size fruit. Nonetheless, the follow-up thinning costs were reduced in 27% and the required time for the operations was significantly reduced, which ended up resulting in a calculated positive economic impact in 14 out of the 20 instances studied along the five trials. The authors concluded that further field studies are needed to achieve a more economical reliable level of thinning and final crop load, especially with the mechanical drum shakers [18].

A blossom-thinning device was developed at Bonn University, which comprehended three horizontal rotors with flexible stems. Any of the rotors could be swung out of the tree row, if this section of the tree was not due for thinning, Field trials were performed over the course of three years, with different rigidity stems, rotor and tractor speeds, in a variety of apple cultivars. It showed to be able to achieve a blossom removal rate from 0% to 33%. Its operation at full power damaged 8% of the leaves. The costs associated with its utilization were around the same values of the labor reduction costs [19], no economic impact calculations were presented.

C. Portable Devices

Two portable devices were used for fruit thinning of peaches for the canning industry (diameters over 56 mm). One device was a Giulivo from the Italian company Volpi S.p.A, consisting of a 2.5 m shaft, weighting about 2 kg, with a rotating head containing six flexible fingers (see Fig. 4 (a)), which is moved by a two speed 12 V electric motor, which in turn is powered by a 12 V, 75 A/h, car battery. The battery

was placed on the ground and transferred the energy across a 15-m long cable. The operator executes the thinning by sweeping across and around each branch of the fruit trees so that the fingers make contact with the fruits and cause them to fall, moving the battery after each 3-4 trees so that it enables the operator to move freely. The second device was a pneumatic limb shaker, produced by Campagnola P.E.S, Italy. It weighs 1.9 kg and works along with an air compressor with a working pressure between 1.0 MPa and 1.2 MPa. It was noticed that its maneuverability was somewhat limited by the air hose. Four different techniques were tested in the fields, combining the use of these devices with follow-up hand thinning. Hand thinning by itself was used as control. In order to improve the process, the workers were told to focus only on fruit clusters, during the complementary hand thinning.



(a) Electrical device with rotary head



(b) Pneumatic limb shaker

Fig. 4 Portable devices used as fruit thinners [4]

The 2008 trials showed that using the pneumatic shaker with a complementary hand thinning reduces the time required for the execution of the operation by 28%, when compared to the 25 to 30 minutes per tree required by hand thinning. Although it did not remove a satisfactory quantity of green fruits, 499 against 1261 from control. The use of the electrical device with a complementary hand thinning, reduced the required time by 46%, comparatively to hand thinning alone and the quantity of removed fruits was fairly closer to control, with a total of 988 removed fruits. These facts showed up as a positive economic impact during the trials of 2008, but not on the 2009 trials, where the use of the pneumatic device was discarded, non-thinning was introduced as control and the use

of the electric device both alone and with a follow-up hand thinning showed a smaller profit per tree to those of both non-thinning and hand thinning [3]. Adding to this variability in economic impact, there are phenomena, which show further inconsistency, like the fact that in some instances the numbers related to the use of the devices alone, are closer to control than those related to the use of the devices with a complementary hand thinning.

The same authors presented a four-year study centered on the use of the electric device represented in Fig. 4 (a), wherein non-thinning was used as control and the corresponding results were compared to hand thinning, mechanical thinning with the electrical device and mechanical thinning along with a follow up hand thinning. Non-thinning consistently presented the greatest value per tree, but this may have occurred due with the fact that the considered prices were those of the canning industry where every fruit over 55 mm is paid equally. The average diameter without thinning had an average of 60 mm, while the ones that received some kind of thinning averaged 66 mm, this may have added value if the fruits were directed towards the fresh market. On the 2009 trials hand thinning showed a greater value per tree than the mechanized method, both with and without follow up hand thinning. On the remaining trials, the mechanized methods resulted in a greater value per tree than the manual method, on some of them the follow up hand thinning increased this value while on others decreased it. The difference of economical results obtained with the different thinning methods was considered insignificant, and the choice of thinning method for this cultivar was rendered indifferent. Despite of this, the mechanized methods did enable the actuation over a smaller time, which by itself, may present as an advantage for the producers [20].

These authors also developed their own thinning equipment depicted in Fig. 5, which the main novelty was the ability to easily exchange the strings of a rotating cylinder and to regulate the rotation speed so that this single equipment could be adapted to suit both blossom and fruit thinning. This machine comprised of a shaft driven by a 12 V electric motor, powered through an electronic variable speed drive, which in turn drew electric power from a petrol-powered generator by means of a 15 m long cable. The motor and the speed drive were placed on a backpack with a metal base and a retractile cover. Strings were produced out of different materials and tested on commercial orchards with different rotational velocities. It was shown that for blossom, thinning the more suitable configuration was the use of flexible plastic strings and high operating speeds, while for green fruit thinning, semi-flexible and rigid stems along with lower operating speeds rendered the best results. It was possible to reduce the time required by up to 93% for flower thinning and 82% for fruit thinning, and the corresponding costs by 92% and 80%, when compared to hand thinning alone. Although, the economic impact was not evaluated, manual fruit thinning removed more fruits than mechanized thinning, resulting in 16% more fruits to reach a grade greater than 55 mm, but simultaneously 12% less total yield [21].



(a) Picture taken during the field trials [21]

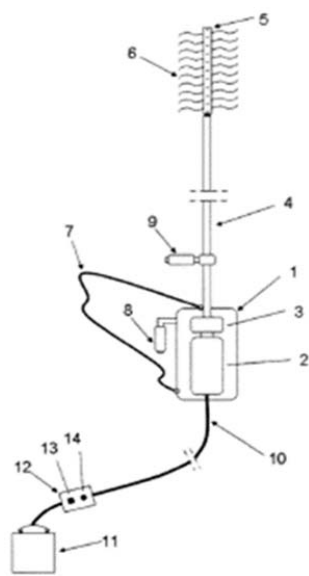

(b) As depicted on its patent [21]

Fig. 5 Electric device with rotating cylinder and exchangeable strings

There are already similar commercially available solutions even though directed to blossom thinning alone. One example of this is the device called Electro'flor from the French company Infaco, which has been a part of studies present in the literature [22]. There are no commercially available portable fruit thinning devices. Electro' flor comprehends a shaft with rotating strings on the upper end and a handle with controls, a power supply connector, a LED, a speed switch and an on/off button, on the bottom end. With a quick touch on the on/off button the device begins rotation [22] until the button is pressed a second time, if otherwise the button is kept pressed for a few seconds, the device enters into a continuous working mode, stopping its rotation as soon as the button is released. A 48 V battery, with a weight of 2.4 kg, which fits into a vest so the operator (see Fig. 6 (b)) conformably carries it, powers the device.

A similar solution is called Cinch (see Fig. 7), its inventor was the North-American Phill Miller. It consists of a shaft with a multitude of flexible strings which coupling is compatible with common drillers, both electric and pneumatic,

it is available in three different sizes, 3, 4, and 5 inches.



(a) Device (b) Battery carrying vest

Fig. 6 Commercially available portable solution for blossom thinning [23]



Fig. 7 Cinch coupled to a driller, and its inventor [24]

Safflowers is another commercially available and similar solution for blossom thinning, although it features a much shorter shaft, being just 37 cm long, including the handle grip. It is available in electrical and pneumatic forms. It weighs around 450 grams and has been studied in field trials of peach and cherry trees' blossom thinning. It looks very similar and may even be related to the first patent presented in the next section (see Fig. 9).

Only one study was found mentioning both sensor and actuation solutions for automated selective thinning. A computer vision system and algorithm were presented with the intent to be paired with an end-effector (see Fig. 8). This work and another one developed by the same authors are presented in detail in next chapter.

D. Selective Thinning

Only one study was found mentioning both sensor and actuation solutions for automated selective thinning. Research was conducted towards the development of a sensor that maps the 3D structure of blooming peach trees, with the ability to distinguish tree canopy from blossoms. A camera system was proposed, based upon three synchronized 3-megapixel cameras and flash illumination for nighttime image acquisition, as well as a stereo vision surface optimization correlation-based algorithm. The results were promising, since most of non-occluded blossoms were located with an average accuracy of less than half of a blossom (1 cm). Although there were matches to the wrong blossoms, yielding position errors, ranging from 20 to 50 mm, that could not be corrected by the validation metrics. Active illumination could correct this

problem. Another issue is the feasibility of application of these algorithms in real time, the processing time in this study was 60–80 sec per binocular pair on 10-megapixel images, requiring half this time without the occlusion cross check. Although if these problems were addressed, and an acceptable 3D mapping of the blossoms was achieved in real-time, this information could be used as input to an algorithm that optimally selects which blossoms should be kept, and the used in the automatic adjustment of speed and orientation of thinning actuators, such as the one depicted in Fig. 8 [25].



Fig. 8 Prototype end effector for automated blossom selective thinning [25]

E. Patents on Portable Thinning Devices

Below are some examples of patents describing portable thinning device. Even though many more exist, the ones here depicted capture the essence of the working principle of all the solutions found on online patents databases.

The invention related to a device for fruit and flower thinning of fruit trees or berry bushes consists of a 250 mm shaft (2), which holds a plurality of filaments of approximately 80 mm long. The patent covers two possible motive power sources, electric and pneumatic, wherein a battery would power the respective motors. The pneumatic version is depicted in Fig. 8. A control valve (4) is coupled to the shaft (2) through an encapsulation (5). This invention's key feature is its short length, reducing the operator's fatigue induced by the vibrations associated with longer shafts. This device resembles Saflovers, a device mentioned on the previous section [26].

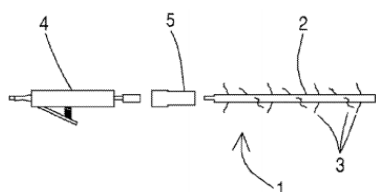

Fig. 9 Patent US2013312322 (A1): “Device for Thinning and Harvesting Fruit and Flowers” [26]

The invention of an ultrasonic targeted electric portable fruit and flower selective thinning machine is shown in Fig. 10. It comprehends a frame, a rotary shaft (17) lodging a set of adhesive tapes (16), an electric motor (14), an ultrasonic

sensor (6), an attack angle adjusting mechanism, a telescopic rod with a control mechanism (9) and a handle (11) in one end, and a coupling to the frame on the opposite end (12). The machine is electrically powered through the plug (7) [27]. Although this device is described as being capable of executing selective thinning, notice that it is manually positioned and that even if it automatically performs an angular regulation, it will probably still hit a considerable number of fruits or buds in an undeliberate manner.

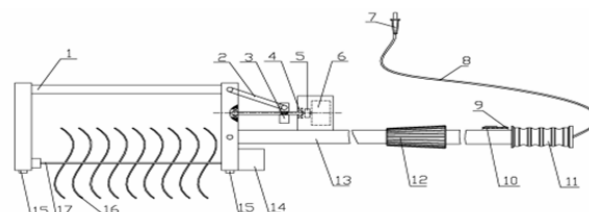

Fig. 10 CN102217493 (A): “Ultrasonic targeted electric flower and fruit thinning machine” [27]

This patent of a fruit defoliating and thinning device for use in fruit trees is depicted in Fig. 11. It comprehends a rotary head (10) with blades (16), a shaft housing (31). The head (10) is moved by a motor (50) that in turn is powered by a battery (60) which also holds a handle (40) with a button (41) that enables the operator to control the blades' rotation. The operator is able to perform the operations within a range of 1 to 3 m [28].

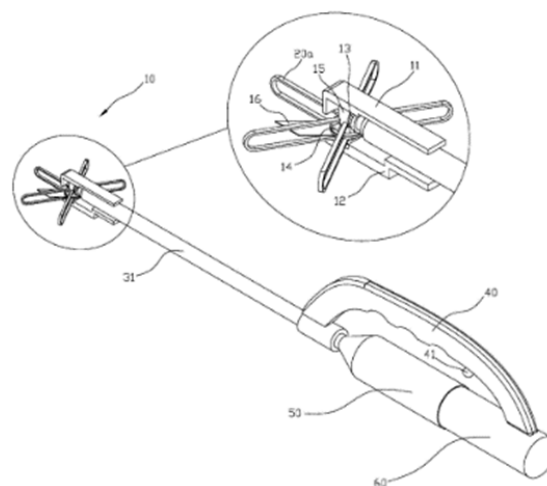

Fig. 11 KR101336350 (B1): “Fruit defoliating and thinning device for use in fruit trees” [28]

The utility model of a flower and fruit-thinning machine comprises a supporting rod (1), a driving device and a flat long-strip-shaped blade (3), wherein the driving device is connected with the supporting rod (1), and the flat long-strip-shaped blade (3) is connected with the driving device. The driving device is responsible for spinning the blade (3) [29]. The principle is shown in Fig. 12.

F. Discussion

Despite the fact that research on this field has begun decades ago, blossom and fruit mechanized thinning remain uncommon practices, mainly due to the inconsistency of positive economic results that experimental trials have been showing, even though in most recent cases are in fact positive when compared with those of hand thinning alone. The inconsistency of results is probably a consequence of the use of non-selective methods, characterized by a random removal of fruits and a heuristic regulation of performance parameters. This is further reinforced by the natural variability of environmental and biological factors that affect fruit trees. Through modal analysis it has been shown that fruit removal is proportional to the limb displacement, this property may be used to increase the predictability of results obtained using trunk and limb shakers. Tree training and the capability of angle adjustment may provide some improvement to string or stem based thinning, but it still does not guarantee any kind of selectivity, even if executed automatically. Portable devices may serve a purpose on more unstructured or smaller orchards where tractor coupled solutions are not appropriate or cannot be implemented, as well as for producers which cannot afford big monetary investments, while still enabling to reduce labor related costs and to actuate in a smaller time window, which is by itself valuable for management purposes. Only one group of authors has been found giving some steps towards selective blossom thinning, having already developed an end effector for using it with computer vision. The thinning actuation mechanisms found are divided in two types: rotary shaft with flexible elements; and shaker. No studies were found to effectively address mechanized selective fruitlet thinning, also, the previously mentioned actuation mechanisms would be inappropriate for this application, since they would likely tend to accidentally remove fruits besides the targeted ones.

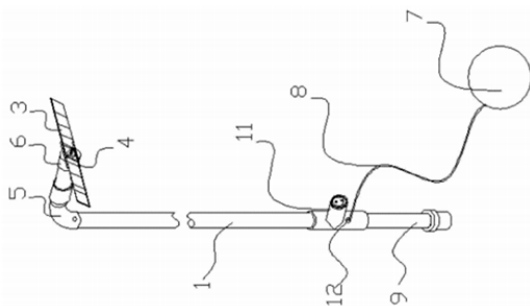

Fig. 12 –CN203327599 (U): “Flower and fruit thinning machine” [29]

III. FRUITS AND VEGETABLES SENSOR TECHNIQUES

A. In-Field Feature Extraction

Selectivity of fruit thinning, in its true deterministic sense, can only be achieved in an automated manner through the use of smart sensors, so that it can in fact detect the presence of fruits, determine their position and evaluate their dimensions, despite of the all the variability and noise that characterizes the typical environment under which thinning operations are

typically executed. No matter what position and angle the sensors are positioned at, there will likely be some kind of obstacle between these sensory elements and the fruit to be detected and evaluated, besides that, wind can make things even more difficult by randomly swinging the branches around.

Continuous Measurement Devices

Many solutions for continuous monitoring and measurement of fruits’ diameter have already been developed. For example, Tukey [30] has used linear displacement transducers, more specifically linear variable differential transformers (LVDT’s), as a means to study not only fruit growth dynamics but also to correlate those dynamics with diurnal fluctuations of environmental factors such as leaf water potential [31], [32]. Other solutions used strain gauges in a Wheatstone bridge configuration, so as to detect the change in resistance of the transducer and generating a voltage proportional to the displacement (see Fig. 13 (a)) [33]. A further development of this device was developed, allowing for a greater displacement before it had to be physically reset [34]. Morandi et al. [35] states that despite the existence of these solutions being commercially available, they are not widely adopted because of their price and because in order for them to serve research and management purposes, a large number of devices would be required. These authors developed a similar low-cost system (about 60€) based on a linear potentiometer.

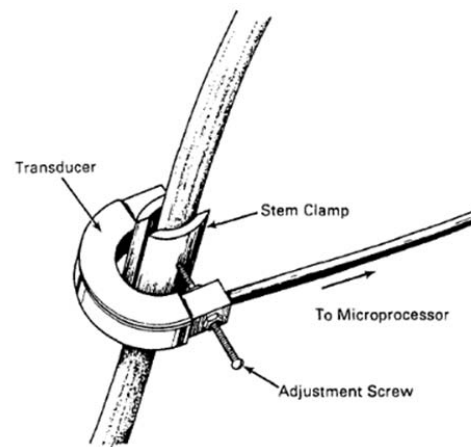

(a) Stem diameter measurement [33]



(b) Fruit size [34]

Fig. 13 Continuous measurement devices

Portable Devices

Iraguen et al. [36] developed a portable non-destructive volume meter for wine grape clusters, depicted in Fig. 14 (a). The device comprehended a sealed chamber formed by two confronting acrylic caps, where the cluster was positioned for measurement, containing an orifice so that the cluster stem could fit, while still attached to the grapevine. A second chamber, held at a negative known reference pressure, was used to extract air from the main chamber. Additionally, it contained two piezo resistive transducers, a temperature sensor and a solenoid valve connecting the two chambers to a vacuum pump. Through the relation between the air displaced between chambers and the equilibrium pressure, attending to Boyle-Mariotte law, the volume of clusters could be determined with a determination coefficient (R2) of 0.954 and a root mean-squared error (RMSE) of 19.3 cm³ (9.8%). An in-field fruit diameter meter was developed and tested, consisting of three fixed rods, forming a tripod, with an ultrasonic range sensor on the top (see Fig. 14 (b)). The tripod was placed in such a manner that the fruit to be measured fit inside and was as near the sensor as possible, touching the rods. The point at which a fruit gets stuck is then dependent on its diameter. So, it becomes possible to estimate the diameter of the fruit, knowing the geometry of the tripod and through the measurement of the distance from the sensor up to the nearest point of the fruit. Trials realized on lemon fields revealed that this device could estimate the fruits' diameters with a RMSE of 2%, although each measurement took 10 seconds [37], [38]. As of today, the measurement time could probably be significantly reduced, since it was most likely elongated due to computational capacity limitations at the time the study was realized.

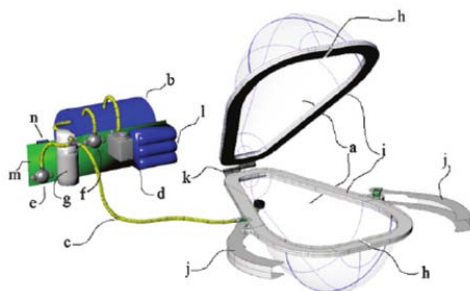

(a) Grape cluster pycnometer [36]

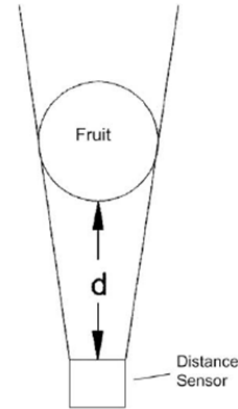

(b) Fruit diameter [37] (Adapted from [38])

Fig. 14 Portable devices

Computer Vision

Computer vision techniques have been increasingly developed and investigated for fruit detection and in-field feature extraction. Also, some efforts have been put into applying these techniques to automated fruit harvesting systems [39]–[45].

The single review article that was found to have a focus on on-tree fruits' detection included only computer vision techniques [46]. Computer vision has also been applied on the development of continuous measurement devices. Pereira [47] did just that, having the objective of plotting fruit growth curves. Zhao et al. [48] developed an on-tree apple detection algorithm, based on 24-bit RGB (Red-Green-Blue color mode) images, with the purpose of supporting robotic harvesting projects. The algorithm transforms the collected images into a redness scale, it performs a contrast texture measurement calculation using a window function and then runs an edge detection based on the texture calculated boundaries. The open edge contours are discarded. The fruits are finally recognized through the application of a given texture value threshold, to the remaining objects. Laplacian filters were shown to reduce false positives associated with the merging of the fruits with the background, which occur due to similar redness values. In the example shown in Fig. 15, the algorithm identified 18 out of 20 fruits.



(a) Original unprocessed image

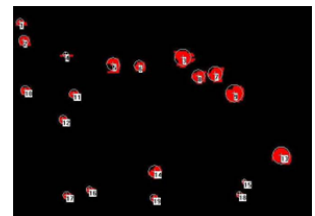

(b) Resulting image with segmented and labeled fruits

Fig. 15 Example of resulting image upon application of an apple recognition algorithm [48]

Zeng et al. [49] described a method for grape diameter continuous field measurement, as an alternative to

displacement transducers, based on a Complementary Metal-Oxide Semiconductor (CMOS) camera, artificial lighting and a computer. It achieved a high accuracy, with an absolute error of 7 μm . The algorithm used a bi-lateral filter as a pre-processing technique in order to remove noise while preserving the edges. The berries are then segmented from the background using an OSTU algorithm and all the remaining objects are labeled. Finally, labeled noisy pixels are removed by area thresholding. The orientation of the fruits is then determined, and the diameter is measured along the horizontal direction of the fruits' axis. Recent research has been trying to approach segmentation techniques with the purpose of removing leaves and branches from collected images, so that fruits are more easily recognized for further feature extraction and properties evaluation. [50]–[52]. A more advanced class of techniques, hyperspectral imaging, combines spatial information gathered through regular visible spectrum cameras with spectroscopy techniques, covering a wide range of wavelengths.

Kohno et al. [53] presented a mobile grading machine for citrus fruits consisting of a mobile mechanism, a differential global positioning system (GPS), a fruit conveyer system, an RGB camera for machine vision, a NIR spectrometer, and a personal computer for control purposes and to register the measurements in a database. It enabled a producer to perform an in-field analysis of fruits' external and internal properties like grade and sugar content, after picking them manually for sampling, as well as to create a mapped database of the crop, associating each measurement to the geographic position where it took place. With other advanced techniques like LIDAR, producers can literally realize a 3D mapping of a whole orchard. Aasted et al. [15] used LIDAR, as a sensor in an angle automatic control system of a Darwin blossom string thinner, in order to increase the efficiency of the thinning and to reduce the operator's fatigue associated with the tractor steering and manual position control of the string thinner. It enabled the operator to drive the tractor following a straight pathway while the thinner adjusted automatically, the adjustment system used in this study was described in Section 2.2. The control strategy of the thinner was an optimal control methodology, involving the definition of a cost function, which represented the lack of engagement of the thinner and the risk of collision, given its current position. This function was then periodically minimized by sequentially adjusting the angle of the thinner through adjacent control states directed towards the smallest cost at each instant.

The images on Fig. 16, where constructed using a system containing a GPS, accelerometers, LIDAR devices and set of stereo cameras, resulting in a point cloud. The study presenting this system was mainly motivated by the need to optimize the mechanization of peach fruitlet and blossom thinning, while serving other applications including yield estimation, variable application of pesticide and other management purposes, since each pixel could additionally contain spectral information related to color and texture [54], [55].

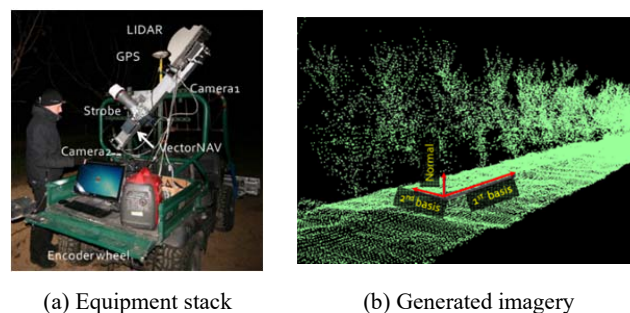

(a) Equipment stack (b) Generated imagery
 Fig. 16 LIDAR system for orchard mapping, sensor and feature extraction [54]

B. Feature Extraction in Industrial Environments

Moreda et al. [37] review the literature focusing on non-destructive technologies for fruit vegetable size determination, saying that these types of systems are of utmost importance for operations both pre- and postharvest. Size can, for example, serve as an in-field ripeness index to predict an optimum harvest time [56]. In the industrial environment, these technologies enable on-line sorting of fruit according to different criteria, not only size, but also soluble-solids or starch content, by taking their correlation with the produce density into account [57], [58], which requires both weight and volume measurements. Even though this review includes a large number of solutions development studies, only two of them relate to portable systems with in-field application (presented in the previous section). There is a reasonable number of review papers focusing mostly on internal qualities evaluation of produce [59]–[62]. Ruiz-Altisent et al. [63] experimented with the fusion of optical and mechanical analysis correlating the combination of data with both external and internal properties of peaches, proving that it could obtain better results than through single measurement procedures. Moreda et al. [37] proposed a comprehensive classification system for the existing electronic techniques to determine produce size, on which the remaining of this review will be based upon:

- Systems based on measuring the volume of the gap between the fruit and an outer casing Time of flight (TOF) range finding systems.
- Systems based on the blocking of light.
- Two-dimensional machine vision systems.
- Three-dimensional machine vision systems.
- Other techniques

Gap Measurement

Gall [64] describes the base algorithm and mathematics necessary for the construction and operation of a ring sensor (see Fig. 17). The emitting and receiving transducers have a Lambertian angular response, i.e. the emitted beams' intensities are taken as being independent of the observer's (receptor) relative positions. The emitters are sequentially triggered around the ring. If no object exists within the interior side of the ring, all of the beams are detected by their respective receptors. Although, if an object is positioned there, given a reasonable number of emitter-receptor pairs, one or

more beams would be intercepted. Each two non-interrupted sequential beams (or chords) can be used to describe the curvature of the object positioned inside the ring. The construction uses multiple reference systems, one for each transmitter. The system's parameters and coordinates are the angles between adjacent transmitters, the angle between each transmitter and the corresponding receptor, the number of transmitters and the ring's radius. The data are compiled in a two-dimensional matrix, where dimension is equal to the number of transmitter transducers. For each n transmitter, the respective receptors' relative positions are stored as a vector $m[n]$. A necessary but limiting condition for the system to work properly is that no more than one object can be inside the ring at once. Some recommendations are given as to how the transducers should be mounted. The suggested algorithm removes redundant chords and enables to estimate the points of interception of the chords with the object. Given a constant displacement and capturing frequency, this system easily enables to plot 3D representations of a given object. It was shown that this system is capable of executing real-time operations, while requiring low computational capacity, due to its modified coordinate system, which uses vectors instead of the more common pixelization. Once the redundant chords are removed, the object's sections can be calculated through the subtraction of the portions of intercepted areas to the total area, which is decomposed in triangles and circular segments by the chords. The 3D construction technique can also be used to perform volume measurements. Moreda et al. [65] determined the optimal conditions for an optical ring system, built upon Gall's work, as an online fruit and vegetable size measurement system. The same authors studied the effect of orientation on the fruit. The ring sensor used Gallium arsenide (GaAs) LED's as emitters and silicon NPN phototransistors as receivers. It was concluded that the optimum displacement speed of the produce to be evaluated, for longitudinal dimensions, was around 2 m/s. Besides that, it was observed that if the fruits oscillated significantly during the measurements, the axes measurements ceased to provide reasonable results, although volume measurements kept presenting a high coefficient of determination (95%) [66].

Nishizu et al. [67] presented a device capable of achieving high accuracy on-line volume measurements, using the Helmholtz resonance phenomenon, although it required a slow displacement speed. It was tested with a maximum conveyor belt speed of 45 mm/s. Kato [68] developed a capacitive sensor for sorting and estimation of soluble solids content of watermelon. It was based on a capacitance meter, which output voltage varied with fruits' volume, showing a higher accuracy, the Helmholtz resonator-based device while simultaneously working with higher displacement speeds, although it required a more rigorous positioning of the fruits.

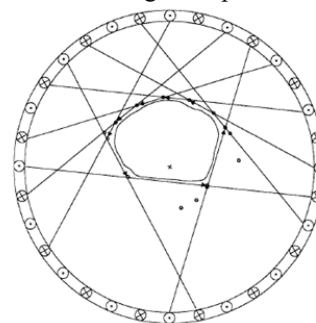

Fig. 17 Optic ring. Final phase of the algorithm on which redundant ropes have been removed [66]

Blocking of Light

The systems developed by Hwamoto and Chuma [69] and Hahn [70] are some examples of that show possible to estimate the size of fruits through the blocking of the light of an array of emitters. Fig. 18 depicts a chilli width sizer, which consisted of a laser diode line generator and a bar of photodetectors standing vertically on the opposite side of the band. It could evaluate both horizontal and vertical dimensions of the fruit, as a conveyor belt at constant velocity transported the fruit and the photodetector bar scanned the laser stripe every 20 ms. A second photodetector array was used to detect the baby suckers, which aligned each chilli during sensor. These sensors were part of a larger sorting system, which also included spectral detection of necrosis and a sorting mechanism.

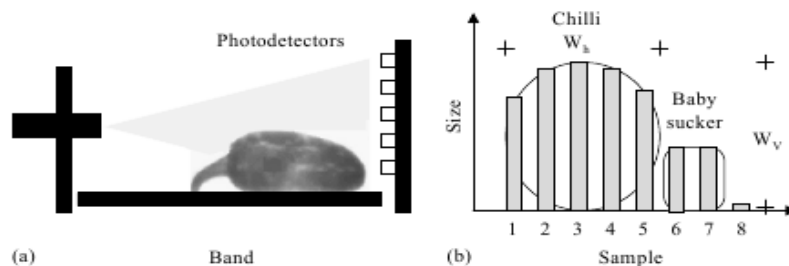

Fig. 18 Chilli size detector for grading system. (a) Laser line generator and photodetectors; (b) sampling measurements with photodetectors [70]

Computer Vision

Today, most packing houses incorporate 2-D computer vision technology in their optical sorters. Besides size and shape, these systems are used to classify produce according to

its color and external defects. The greatest limitation to applicability of computer vision to horticultural produce inspection is the appearance of reflections, which tend to saturate charge-coupled device (CCD) and CMOS sensors

used in most cameras. This problem is usually solved with the use of indirect lighting, the use of filters mounted over the cameras' lenses or by using cameras with the less common Charge Injection Device (CID) sensors, which do not saturate as easily. In a typical system, fruits travel on a conveyor belt and are observed from above by one or more cameras. Sometimes lateral mirrors are installed in order to increase the number of views [37]. The techniques applied on these systems differ mostly in the algorithms they use for the extraction of features. There is a vast availability of literature regarding this, including many review articles focusing on solutions and problems for applications such as size estimation and external defects' detection [48], [50], [70]–[83] or non-destructive firmness sensor [84]. Multispectral and hyperspectral imaging technology have been in the spotlight of research, as it enables to combine the capabilities of spatial imaging with spectroscopy, hence presenting the potential to provide valuable data related to both internal and external features of horticultural produce [60], [85]–[90]. Three-dimensional computer vision is also being gradually introduced in industrial applications, mainly because it permits more accurate volume measurements than those attainable with regular two-dimensional imaging. Three-dimensional imaging can be classified as active or passive, attending to the fact of whether or not it uses structured lighting. Both of them use cues such as motion, stereo imaging, shadows or contours, in order to estimate surfaces' shapes or the orientation of a surface at a given point. Although none of these cues, except stereo, is capable of performing a direct depth measurement, requiring some assumptions to be taken in consideration [37]. A different approach for depth measurement is the fusion of data acquired through time of flight sensors with the graphical information acquired through a camera. These sensors provide true topographical information and can be used for shape and texture determination, even without using any camera [60].

Time of Flight

An extensive work has been developed regarding the implementation of ultrasonic transducers in food engineering, its theory and principles have been well documented, and an extensive number of applications has been suggested [91]–[93]. Ultrasonic transducers can be used for extraction of both

internal and external properties of fruits, since the response of the produce once excited by an ultrasonic wave has an observable correlation with mechanical parameters like elasticity, geometry and density. Frequencies below 200 kHz and high amplitudes have shown to work the best for features extraction in horticultural produce. [62], [94], [95]. On the other hand, it has also been shown that horticultural produce presents a high attenuation coefficient for frequencies between 0.5 MHz and 1 MHz, typically used in medical applications and in several industry sectors [94]. Lee & Cho [96] investigated the feasibility of using a non-contact ultrasonic technique to measure fruit firmness. Using a 500 kHz transducer to emit a wave against samples of apple and peach and performing a Fast Fourier Transform (FFT) of the various reflected signals. Multiple linear regression models were developed using distance correction factors to predict the bio yield strength and the apparent elastic modulus, achieving determination coefficients over 0.82 for both fruits. It was observed that the value of the ratio of the magnitude of the second reflected signal to the magnitude of the first reflected signal divided by the ratio of the TOF (time of flight) of the second reflected signal to the TOF of the first reflected signal is always constant, regardless of changes in the distance between the ultrasonic transducer and sample surface. Methods using two ultrasonic transducers require an accurate relative positioning which makes it difficult to apply such methods on non-controlled environments. Morrison & Abeyratne [95] developed a system with a single 100 kHz transducer for the evaluation of multiple parameters, such as water content and firmness of oranges (see Fig. 19). It was powered by two 9 V batteries. The reflected signals were acquired through a 12 bit, 3 MSPS ADC (Analog to digital converter) and amplified by a precision instrumentation amplifier. Digital signal processing (DSP) techniques were used to analyze the recorded return signal, in favor of analogue equivalents in hardware, allowing the device to be easily adapted to use different signal processing techniques. An on-board ARM microcontroller was used to generate waveforms for driving the transducer, and for recording and processing the return path signal.

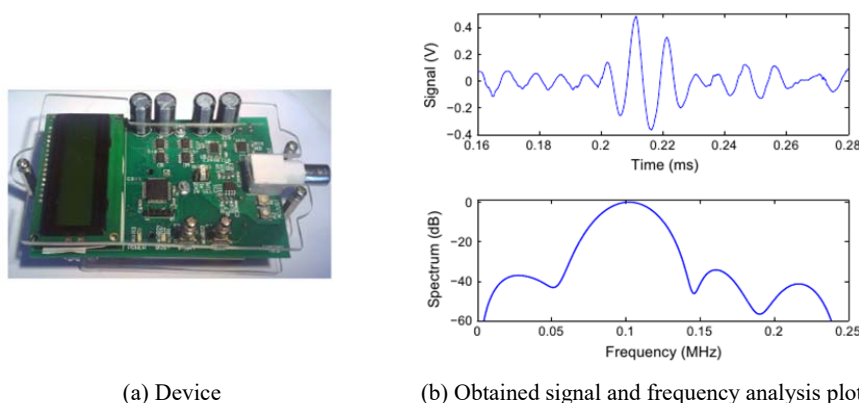

Fig. 19 Portable ultrasound system [95]

Other Techniques

The last category as defined by [37], includes high-energy techniques like microwaves, x-ray and magnetic resonant imaging (MRI) and any other that do not fit the categories presented above. Particularly magnetic resonant imaging has been investigated several times regarding its feasibility as an on-line horticultural produce defect detection and internal properties extraction system. This technique works by plotting the density distribution of protons, or hydrogen nuclei, which resonate with an appropriate magnetic field, generated by the devices [97]. Most studies involving the use of MRI in the food industry have been undertaken with commercial equipment designed for medical purposes. Such equipment operates at high magnetic field strength of more than 2T with high performance and expensive hardware requiring high initial capital investments [60], and this investment does not seem to justify itself when the application is something as simple as size determination alone [37]. NIR spectroscopy has also been toughly investigated for internal properties evaluation, with wavelengths spanning from 780 nm to 2500 nm. In these techniques, the produce is irradiated and, either the reflected or the transmitted portion of radiation is captured and analyzed. When the emitted wave penetrates and interacts with the fruits or vegetables, its spectral content is altered due to phenomenon of dispersion and absorption, according to the produce's chemical composition and microstructure [98]. It is predictable that a miniaturization of spectroscopy technology will occur and with this, its usefulness can be extended towards pre-harvest and in-field applications [99]. Another interesting interval of the electromagnetic spectrum is terahertz radiation (100 GHz to 4 THz), located between the millimeter zones of infrared and microwaves. A variety of substances tends to show an accentuated decline in opacity when compared to radiation of close by frequencies, while remaining non-ionizing [62]. It has been applied in horticultural related applications, for example, to detect residues of pesticides on harvested fruits through the observation that the absorption peaks occurred in different points of the spectra, according to whether the irradiated area had pesticides or not [100].

C. Discussion

Continuous measurement devices are inherently static and require an accurate manual positioning, so that they can provide information regarding the diameter of fruits or stems, so they can only serve monitoring purpose, not real-time dynamic sensor. The presented in-field portable devices do have mobility but they still require manual positioning of the produce to be evaluated. Although there is a significant number of studies concerning in-field detection and external feature extraction through computer vision techniques, the main trend in the literature, on which the authors claim that their ultimate purpose is to support the development of agricultural processes automation, not many studies show attempts to effectively incorporate these technologies in some kind of product [46]. Additionally, the few attempts that do show up do not seem to have an advantage over the equivalent

manual methods, being usually more limited by the actuation mechanisms than by the sensor technologies, even though when it comes to fruit detection on the trees, some improvement in detection rate is still required to motivate their adoption. Besides that, when it comes to fruit trees, visible spectrum-based computer vision may not prove too useful, since often most of the fruits are occluded by branches and leaves when observed from outside of the canopy. Gap measurement solutions may be interesting for in-field solutions since the sensors can be positioned in a mobile structure, providing dynamic radial points of view. Time of flight sensors may overcome many problems that affect computer vision, like the appearance of shadows, the lack of depth information or the confusion of regions presenting similar optical properties, although they also suffer from the problems related to the occlusion when it comes to fruit detection. Therefore, alternatives to reduce total occlusion must be investigated, involving the use of non-traditional sensors that capture absorption properties that differentiate fruits from leaves. This approach should generate images or plots where leaves were not visible and where only fruit were displayed, allowing for an easy detection process [46]. These properties are not easily obtained though. Either using electromagnetic or mechanical waves, unless high power equipment is used, the attenuation through air will likely turn any existing differentiable feature into something hardly detectable. Although, ultrasonic waves and NIR spectroscopy have been applied as range sensors, as source of excitation for spectroscopy techniques and have been applied multiple times, with some degree of success, in fruits and vegetables, machine learning algorithms, whether implemented in field or used off-line as a research and study tool, may provide a way to solve this kind of problems, since they enable to isolate non-self-evident patterns and features.

IV. CONCLUSIONS

Most research related to mechanized fruit thinning concerns non-selective methods and none of the solutions present in the literature, has shown an insufficiently consistent positive economic impact to motivate its wide adoption. The way to solve this problem deterministically likely resides on moving towards selective methods, which inevitably need to incorporate some kind of sensor technology. Some authors are already working in that sense, applying techniques like LIDAR and computer vision, with automated selective thinning as an end goal. Although these approaches are proper only for big and neatly structured orchards, since the related equipment is relatively large and expensive, those techniques are being investigated in the sense of giving continuity to tractor-coupled solutions. Portable devices may serve a purpose on more unstructured orchards, in what concerns sensor methods, on-tree fruit detection major challenge is to overcome the problem of fruits' occlusion by leaves and branches, hence nontraditional sensors capable of differentiation should be investigated.

ACKNOWLEDGMENT

This work was developed as part of +Pêssego project which purpose is to promote the innovation and development of peach tree culture in the region of Beira Interior, Portugal. This project was financed by a national rural development and support program, PRODER.

REFERENCES

[1] Akdag, R.; Danzon, M.: "European charter on countering obesity" WHO European Ministerial conference on counteracting obesity., no (2006).

[2] Berlage, A.; Langmo, R.: "Machine-vs hand-thinning of peaches." Transactions of the American Society of Agricultural Engineers (ASAE), Vol. 25 n.º 3 (1982), pp. 538-543.

[3] Martin, B.; Torregrosa, A.; Brunton, J. G.: "Post-bloom thinning of peaches for canning with hand-held mechanical devices" Scientia Horticulturae, Vol. 125 no 4 (2010), pp. 658–665.

[4] Diezma, B.; Rosa, U.: "Monitoring of fruit removal for mechanical thinning of peaches" Frutic, Vol. 5 no (2005), pp. 12–16.

[5] Rosa, U.; Cheetancheri, K.; Gliever, C.; Lee, S.; Thompson, J.; Slaughter, D.: "An electro-mechanical limb shaker for fruit thinning" Computers and Electronics in Agriculture, Vol. 61 no 2 (2008), pp. 213–221.

[6] Baugher, T. A.; Elliott, K. C.; Leach, D. W.; Horton, B.; Miller, S. S.: "Improved methods of mechanically thinning peaches at full bloom" Journal of the American Society for Horticultural Science, Vol. 116 no 5 (1991), pp. 766–769.

[7] Glenn, D. M.; Peterson, D. L.; Giovannini, D.; Faust, M.: "Mechanical thinning of peaches is effective postbloom" HortScience, Vol. 29 no 8 (1994), pp. 850–853.

[8] Peach blossom thinning device, Phil Brown (accessed 2018, September 24). Retrieved from <http://www.philbrownwelding.com/index.php/peach-blossom-thinner>.

[9] Schupp, J.; Baugher, T. A.; Miller, S.; Harsh, R.; Lesser, K.: "Mechanical thinning of peach and apple trees reduces labor input and increases fruit size" HortTechnology, Vol. 18 no 4 (2008), pp. 660–670.

[10] Baugher, T. A.; Schupp, J.; Lesser, K.; Hess-Reichard, K.: "Horizontal string blossom thinner reduces labor input and increases fruit size in peach trees trained to open-center systems" HortTechnology, Vol. 19 no 4 (2009), pp. 755–761.

[11] Baugher, T. A.; Schupp, J.; Ellis, K.; Remcheck, J.; Winzeler, E.; Duncan, R.; Johnson, S.; Lewis, K.; Reighard, G.; Henderson, G.; others: "String blossom thinner designed for variable tree forms increases crop load management efficiency in trials in four United States peach-growing regions" HortTechnology, Vol. 20 no 2 (2010), pp. 409–414.

[12] Darwin 300, blossom thinner with flexible stems. (accessed 2018, September 24). Retrieved from <http://fruit-tec.com/en/202200-2>.

[13] USDA drum-shaker, fruit thinner. (accessed 2018, September 24). Retrieved from https://ucanr.edu/sites/fruitreport/Thinning/Mechanical_Thinning/.

[14] Dise, R.; Heinemann, P.: "Automated String Thinner Positioning" 2011 Mid-Atlantic Fruit and Vegetable Convention, Hershey Lodge and Convention Center, Hershey, Pennsylvania, USA (2011).

[15] Aasted, M.; Dise, R.; Auxt Baugher, T.; Schupp, J. R.; Heinemann, P. H.; Singh, S.: "Autonomous Mechanical Thinning Using Scanning LIDAR", 2011 ASABE Annual International Meeting, Louisville, Kentucky, (2011).

[16] Johnson, R. S.; Phene, B.; Slaughter, D.; DeJong, T.; Day, K.; Duncan, R.; Norton, M.; Hasey, J.: "Mechanical Blossom Thinning Using a Darwin String Thinner" CTFA Annual Research Report, no (2010).

[17] Glozer, K.; Hasey, J.: "Mechanical thinning in cling peach" HortScience, Vol. 41 no 4 (2006), pp. 995–995.

[18] Miller, S. S.; Schupp, J. R.; Baugher, T. A.; Wolford, S. D.: "Performance of mechanical thinners for bloom or green fruit thinning in peaches" HortScience, Vol. 46 no 1 (2011), pp. 43–51.

[19] Blanke, M.; Damerow, L.: A novel device for precise and selective thinning in fruit crops to improve fruit quality. International Symposium on Application of Precision Agriculture for Fruits and Vegetables, ISHS Acta Horticulturae 824 (2009), pp. 275–280.

[20] Martin-Gorritz, B.; Torregrosa, A.; Brunton, J.G.: "Post-bloom mechanical thinning for can peaches using a hand-held electrical device"

Scientia Horticulturae, Vol. 144 no (2012), pp. 179–186.

[21] Martin-Gorritz, B.; Mira, A. T.; Brunton, J. G.; Pallares, R. A.: A Hand-held Mechanical Blossom and Post-bloom Thinning Device for Peach Trees. (Power and Machinery. International Conference of Agricultural Engineering-CIGR-AgEng 2012: agriculture and engineering for a healthier life, Valencia, Spain, 8-12 July 2012), pp. P-0154.

[22] Simões, M. P.; Vuleta, I.; Belusic, N.: "Monda mecânica de flores com equipamento electro flor em pessegueiros da cultivar Rich Lady" Revista de Ciências Agrárias, Vol. 36 no 3 (2013), pp. 297–302.

[23] Commercially available portable solution for blossom thinning (accessed 2018, September 24). Retrieved from https://www.infaco.com/fr/les-produits/powercoup-pw2/fiche-produit/#pw2_eclaircisseuse.

[24] Cinch coupled to a driller, and its inventor accessed 2018, September 24). Retrieved from <https://fruitgrowersnews.com/article/new-device-makes-peach-thinning-a-cinch/>.

[25] Nielsen, M.; Slaughter, D. C.; Gliever, C.: "Vision-based 3D peach tree reconstruction for automated blossom thinning" Industrial Informatics, IEEE Transactions on, Vol. 8 no 1 (2012), pp. 188–196.

[26] "Patent US2013312322 (A1), Device for Thinning and Harvesting Fruit and Flowers, 28 Nov. 2013."no (n.d.).

[27] "Patent CN102217493 (A), Ultrasonic targeted electric flower and fruit thinning machine, Oct 19, 2011."no (n.d.).

[28] "Patent KR101336350 (B1), Fruit defoliating and thinning device for use in fruit trees, Dec 4, 2013"no (n.d.).

[29] "Patent CN203327599 (U), Flower and fruit thinning machine, Dec 11, 2013."no (n.d.).

[30] Tukey, L.: "A linear electric device for continuous measurement and recording of fruit enlargement and contraction" Journal of the American Society for Horticultural Science, Vol. 84 no (1964), pp. 653–660.

[31] Klepper, B.; Browning, V. D.; Taylor, H. M.: "Stem diameter in relation to plant water status" Plant Physiology, Vol. 48 no 6 (1971), pp. 683–685.

[32] Higgs, K.; Jones, H.: "A microcomputer-based system for continuous measurement and recording fruit diameter in relation to environmental factors" Journal of Experimental Botany, Vol. 35 no 11 (1984), pp. 1646–1655.

[33] Beedlow, P. A.; Daly, D. S.; Thiede, M. E.: "A new device for measuring fluctuations in plant stem diameter: Implications for monitoring plant responses: Note." Environmental Monitoring and Assessment, Vol. 6 no 3 (1986), pp. 277–82.

[34] Link, S.; Thiede, M.; Van Bavel, M.: "An improved strain-gauge device for continuous field measurement of stem and fruit diameter" Journal of Experimental Botany, Vol. 49 no 326 (1998), pp. 1583–1587.

[35] Morandi, B.; Manfrini, L.; Zibordi, M.; Noferini, M.; Fiori, G.; Grappadelli, L. C.: "A low-cost device for accurate and continuous measurements of fruit diameter" HortScience, Vol. 42 no 6 (2007), pp. 1380–1382.

[36] Iraguen, V.; Guesalaga, A.; Agosin, E.: "A portable non-destructive volume meter for wine grape clusters" Measurement Science and Technology, Vol. 17 no 12 (2006), pp. N92.

[37] Moreda, G.; Ortiz-Cañavate, J.; Garcí'a-Ramos, F. J.; Ruiz-Altisent, M.: "Non-destructive technologies for fruit and vegetable size determination-a review" Journal of Food Engineering, Vol. 92 no 2 (2009), pp. 119–136.

[38] Laing, A.; Smit, Q.; Mortimer, B.; Tapson, J.: "Ultrasonic fruit sizing device" Journal of the South African Acoustics Institute, Vol. 6 no (1995), pp. 60–65.

[39] Jiménez, A. R.; Jain, A. K.; Ceres, R.; Pons, J.: "Automatic fruit recognition: a survey and new results using range/attenuation images" Pattern recognition, Vol. 32 no 10 (1999), pp. 1719–1736.

[40] Scarfe, A. J.; Flemmer, R. C.; Bakker, H.; Flemmer, C.L.: Development of an autonomous kiwifruit picking robot. (4th International Conference on Autonomous Robots and Agents, 2009. ICARA 2009), pp. 380–384.

[41] Ceres, R.; Pons, J.; Jimenez, A.; Martin, J.; Calderon, L.: "Design and implementation of an aided fruit-harvesting robot (AgriBot)" Industrial Robot: An International Journal, Vol. 25 no 5 (1998), pp. 337–346.

[42] Baeten, J.; Donné, K.; Boedrij, S.; Beckers, W.; Claesen, E.: Autonomous fruit picking machine: A robotic apple harvester. (Field and Service Robotics), pp. 531–539.

[43] Li, P.; Lee, S.; Hsu, H.-Y.: "Review on fruit harvesting method for potential use of automatic fruit harvesting systems" Procedia Engineering, Vol. 23 no (2011), pp. 351–366.

[44] Edan, Y.: "Design of an autonomous agricultural robot" Applied Intelligence, Vol. 5 no 1 (1995), pp. 41–50.

[45] De-An, Z.; Jidong, L.; Wei, J.; Ying, Z.; Yu, C.: "Design and control of

- an apple harvesting robot" *Biosystems Engineering*, Vol. 110 no 2 (2011), pp. 112–122.
- [46] Jimenez, A.; Ceres, R.; Pons, J.; others: "A survey of computer vision methods for locating fruit on trees" *Transactions of the American Society of Agricultural Engineers (ASAE)*, Vol. 43 no 6 (2000), pp. 1911–1920.
- [47] Pereira, C. A. P.: "Utilización de imágenes digitales para medición del diámetro de frutos de Mandarina (*Citrus reticulata*) en crecimiento." *Revista Ciencia y Tecnología*, Vol. 6 no 1 (2013), pp. 1–9.
- [48] Zhao, J.; Tow, J.; Katupitiya, J.: "On-tree fruit recognition using texture properties and color data. (2005 IEEE/RSJ International Conference on Intelligent Robots and Systems, 2005 (IROS 2005)), pp. 263–268.
- [49] Zeng, Q.; Liu, C.; Miao, Y.; Fei, S.; Wang, S.: "A machine vision system for continuous field measurement of grape fruit diameter. (IITA'08. Second International Symposium on Intelligent Information Technology Application, 2008.), pp. 1064–1068.
- [50] Yang, L.; Dickinson, J.; Wu, Q.; Lang, S.: "A fruit recognition method for automatic harvesting. (14th International Conference on Mechatronics and Machine Vision in Practice, 2007. M2VIP 2007), pp. 152–157.
- [51] Patel, H.; Jain, R.; Joshi, M.: "Automatic segmentation and yield measurement of fruit using shape analysis" *International Journal of Computer Applications*, Vol. 45 no 7 (2012), pp. 19–24.
- [52] Bulanon, D.; Kataoka, T.; Ota, Y.; Hiroma, T.: "AE—automation and emerging technologies: a segmentation algorithm for the automatic recognition of Fuji apples at harvest" *Biosystems Engineering*, Vol. 83 no 4 (2002), pp. 405–412.
- [53] Kohno, Y.; Kondo, N.; Iida, M.; Kurita, M.; Shiigi, T.; Ogawa, Y.; Kaichi, T.; Okamoto, S.: "Development of a mobile grading machine for citrus fruit" *Engineering in agriculture, Environment and Food*, Vol. 4 no 1 (2011), pp. 7–11.
- [54] Nielsen, M.; Slaughter, D.C.; Gliever, C.; Upadhyaya, S.: "Orchard and tree mapping and description using stereo vision and lidar. SPC-03: IV International Workshop on Computer Image Analysis in Agriculture (2012).
- [55] Nielsen, M.; Slaughter, D.; Gliever, C.: "Stereo vision blossom mapping for automated thinning in peach. (2010 IEEE International Symposium on Industrial Electronics (ISIE)), pp. 499–504.
- [56] Hahn, F.; Sanchez, S.: "Carrot volume evaluation using imaging algorithms" *Journal of Agricultural Engineering Research*, Vol. 75 no 3 (2000), pp. 243–249.
- [57] Hoffmann, T.; Wormanns, G.; Füll, C.; Poller, J.: "A system for determining starch in potatoes online" *Res. Papers Lithuanian Inst. Agric. Eng. Lithuanian Univ. Agric.*, 37 (2005), pp. 34–43.
- [58] Jordan, R. B.; Clark, C. J.: "Sorting of kiwifruit for quality using drop velocity in water" *Transactions of the ASAE*, Vol. 47 no 6 (2004), pp. 1991–1998.
- [59] Alfati, M. S. M.; Shariff, A. R. M.; Abdullah, M. Z.; Marhaban, M. H. B.; Saeed, O. M. B.: "The application of internal grading system technologies for agricultural products—Review" *Journal of Food Engineering*, Vol. 116 no 3 (2013), pp. 703–725.
- [60] Ruiz-Altisent, M.; Ruiz-García, L.; Moreda, G.; Lu, R.; Hernandez-Sanchez, N.; Correa, E.; Diezma, B.; Nicolai, B.; Garcia-Ramos, J.: "Sensors for product characterization and quality of specialty crops—A review" *Computers and Electronics in Agriculture*, Vol. 74 no 2 (2010), pp. 176–194.
- [61] Opara, U. L.; Pathare, P. B.: "Bruise damage measurement and analysis of fresh horticultural produce—A review" *Postharvest Biology and Technology*, Vol. 91 no (2014), pp. 9–24.
- [62] Butz, P.; Hofmann, C.; Tauscher, B.: "Recent developments in noninvasive techniques for fresh fruit and vegetable internal quality analysis" *Journal of Food Science*, Vol. 70 no 9 (2005), pp. R131–R141.
- [63] Ruiz-Altisent, M.; Lleó, L.; Riquelme, F.: "Instrumental quality assessment of peaches: fusion of optical and mechanical parameters" *Journal of Food Engineering*, Vol. 74 no 4 (2006), pp. 490–499.
- [64] Gall, H.: "A ring sensor system using a modified polar coordinate system to describe the shape of irregular objects" *Measurement Science and Technology*, Vol. 8 no 11 (1997), pp. 1228.
- [65] Moreda, G.; Ortiz-Cañavate, J.; García-Ramos, F.; Homer, I.; Ruiz-Altisent, M.: "Optimal operating conditions for an optical ring sensor system to size fruits and vegetables" *Applied Engineering in Agriculture*, Vol. 21 n.º 4 (2005), pp. 661–670.
- [66] Moreda, G.; Ortiz-Cañavate, J.; García-Ramos, F.; Ruiz-Altisent, M.: "Effect of orientation on the fruit on-line size determination performed by an optical ring sensor" *Journal of Food Engineering*, Vol. 81 no 2 (2007), pp. 388–398.
- [67] Nishizu, T.; Ikeda, Y.; Torikata, Y.; Manmoto, S.; Umehara, T.; Mizukami, T.: "Automatic, continuous food volume measurement with a Helmholtz resonator" *International Commission of Agricultural Engineering (CIGR, Commission Internationale du Genie Rural) E-Journal Volume 3 (2001):*
- [68] Kato, K.: "Electrical density sorting and estimation of soluble solids content of watermelon" *Journal of Agricultural Engineering Research*, Vol. 67 no 2 (1997), pp. 161–170.
- [69] Hwamoto, M.; Chuma, Y., 1982: "Recent studies on development in automated citrus packinghouse facility in Japan. Proceedings of the International Society of Citriculture International Citrus Congress November 9–12, Tokyo, Japan.
- [70] Hahn, F.: "PH—Postharvest Technology: Automatic Jalapeño Chilli Grading by Width" *Biosystems Engineering*, Vol. 83 no 4 (2002), pp. 433–440.
- [71] Blasco, J.; Aleixos, N.; Moltó, E.: "Machine vision system for automatic quality grading of fruit" *Biosystems Engineering*, Vol. 85 no 4 (2003), pp. 415–423.
- [72] Afrisal, H.; Faris, M.; Utomo, P.; Grezelda, L.; Soesanti, I.; Andri, F.; others: "Portable smart sorting and grading machine for fruits using computer vision. Computer, Control, Informatics and Its Applications (IC3INA), 2013 International Conference on], pp. 71–75.
- [73] Zhang, B.; Huang, W.; Li, J.; Zhao, C.; Fan, S.; Wu, J.; Liu, C.: "Principles, developments and applications of computer vision for external quality inspection of fruits and vegetables: A review" *Food Research International*, Vol. 62 no (2014), pp. 326–343.
- [74] Ninomiya, K.; Kondo, N.; Chong, V.; Monta, M.: "Machine vision systems of eggplant grading system. (Automation Technology for Off-Road Equipment, Proceedings of the 7-8 October 2004 Conference, Kyoto, Japan).
- [75] Brosnan, T.; Sun, D.-W.: "Improving quality inspection of food products by computer vision—a review" *Journal of Food Engineering*, Vol. 61 no 1 (2004), pp. 3–16.
- [76] Vaidya, A.; Pujari, D.; Desai, H.; Borse, K.; Patel, S.: "Leaf Recognition—A Technical Review" *International Journal for Research in Emerging Science and Technology*, Vol. 2 n.º 1 (2015).
- [77] Ji, B.; Zhu, W.; Liu, B.; Ma, C.; Li, X.: "Review of recent machine-vision technologies in agriculture. (Second International Symposium on Knowledge Acquisition and Modeling, 2009. KAM'09), pp. 330–334.
- [78] Dang, H.; Song, J.; Guo, Q.: "A Fruit Size Detecting and Grading System Based on Image Processing. (2010 2nd International Conference on Intelligent Human-Machine Systems and Cybernetics (IHMSC)), pp. 83–86.
- [79] Studman, C.: "Computers and electronics in postharvest technology—a review" *Computers and Electronics in Agriculture*, Vol. 30 no 1 (2001), pp. 109–124.
- [80] Mustafa, N.; Gandi, S.; Sharrif, Z.; Ahmed, S.: "Real-time implementation of a fuzzy inference system for banana grading using DSP TMS320C6713 platform. (2010 IEEE Student Conference on Research and Development (SCORED)), pp. 324–328.
- [81] Wulfsohn, D.; Gundersen, H. J. G.; Vedel Jensen, E. B.; Nyengaard, J. R.: "Volume estimation from projections." *Journal of Microscopy*, Vol. 215 no Pt 2 (2004), pp. 111–20.
- [82] Menguito, B. P.; Nagata, M.; Qixin, C.; others: "Study on sorting system for strawberry using machine vision" *Journal of JSAM*, Vol. 62 no 1 (2000), pp. 100–110.
- [83] Nagata, M.; Cao, Q.; Shrestha, B.; Kinoshita, O.: "Basic study on strawberry sorting system in Japan. 1997 ASAE Annual International Meeting Technical Papers], pp. 49085–9659.
- [84] Garcia-Ramos, F.J.; Valero, C.; Homer, I.; Ortiz-Cañavate, J.; Ruiz-Altisent, M.: "Non-destructive fruit firmness sensors: a review" *Spanish Journal of Agricultural Research*, Vol. 3 no 1 (2005), pp. 61–73.
- [85] Lorente, D.; Aleixos, N.; Gómez-Sanchis, J.; Cubero, S.; García-Navarrete, O. L.; Blasco, J.: "Recent advances and applications of hyperspectral imaging for fruit and vegetable quality assessment" *Food and Bioprocess Technology*, Vol. 5 no 4 (2012), pp. 1121–1142.
- [86] Burger, J.: "Hyperspectral NIR image analysis. Ph. D. thesis, pub. epsilon. sl. se, Umeå, Sweden.
- [87] Aleixos, N.; Blasco, J.; Navarrón, F.; Moltó, E.: "Multispectral inspection of citrus in real-time using machine vision and digital signal processors" *Computers and Electronics in Agriculture*, Vol. 33 no 2 (2002), pp. 121–137.
- [88] Blasco, J.; Aleixos, N.; Gómez-Sanchis, J.; Moltó, E.: "Recognition and classification of external skin damage in citrus fruits using multispectral

- data and morphological features" *Biosystems Engineering*, Vol. 103 no 2 (2009), pp. 137–145.
- [89] Lathuiliere, A.; Mansouri, A.; Voisin, Y.; Marzani, F.; Gouton, P.: "Stereoscopic system for 3D reconstruction using multispectral camera and LCD projector" *The Imaging Science Journal*, Vol. 54 no 1 (2006), pp. 19–28.
- [90] Wang, N.-N.; Sun, D.-W.; Yang, Y.-C.; Pu, H.; Zhu, Z.: "Recent Advances in the Application of Hyperspectral Imaging for Evaluating Fruit Quality" *Food Analytical Methods*, no (2015), pp. 1–14.
- [91] Povey, M. J.: "Ultrasonics of food" *Contemporary Physics*, Vol. 39 no 6 (1998), pp. 467–478.
- [92] Povey, M.: "Ultrasonics in food engineering Part II: Applications" *Journal of Food Engineering*, Vol. 9 no 1 (1989), pp. 1–20.
- [93] Povey, M.; McClements, D.: "Ultrasonics in food engineering. Part I: Introduction and experimental methods" *Journal of Food Engineering*, Vol. 8 no 4 (1988), pp. 217–245.
- [94] Mizrach, A.: "Ultrasonic technology for quality evaluation of fresh fruit and vegetables in pre-and postharvest processes" *Postharvest Biology and Technology*, Vol. 48 no 3 (2008), pp. 315–330.
- [95] Morrison, D.; Abeyratne, U.: "Ultrasonic technique for non-destructive quality evaluation of oranges" *Journal of Food Engineering*, Vol. 141 no (2014), pp. 107–112.
- [96] Lee, S.; Cho, B.-K.: Evaluation of the firmness measurement of fruit by using a non-contact ultrasonic technique. (2013 8th IEEE Conference on Industrial Electronics and Applications (ICIEA)), pp. 1331–1336.
- [97] Patel, K. K.; Khan, M. A.; Kar, A.: "Recent developments in applications of MRI techniques for foods and agricultural produce—an overview" *Journal of Food Science and Technology*, Vol. 52 no 1 (2015), pp. 1–26.
- [98] Nicolai, B. M.; Beullens, K.; Bobelyn, E.; Peirs, A.; Saeys, W.; Theron, K. I.; Lammertyn, J.: "Nondestructive measurement of fruit and vegetable quality by means of NIR spectroscopy: A review" *Postharvest Biology and Technology*, Vol. 46 no 2 (2007), pp. 99–118.
- [99] Walsh, K. B.: "Commercial adoption of technologies for fruit grading, with emphasis on NIRS" *Information and technology for sustainable fruit and vegetable production, Frutic*, Vol. 5 no (2005).
- [100] Ma, Y.; Wang, Q.; Wang, X.; Wang, H.: Research of pesticide residues on fruit by terahertz spectroscopy technology. [International Conference on Optical Instruments and Technology (OIT2011)], pp. 820125–820125.
- [101]