

Loss Reduction and Reliability Improvement of Industrial Distribution System through Network Reconfiguration

Ei Ei Phyu, Kyaw Myo Lin, Thin Thin Moe

Abstract—The paper presents an approach to improve the reliability and reduce line losses of practical distribution system applying network reconfiguration. The change of the topology redirects the power flow within the distribution network to obtain better performance of the system. Practical distribution network (Pyigyitagon Industrial Zone (I)) is used as the case study network. The detailed calculations of the reliability indices are done by using analytical method and power flow calculation is performed by Newton-Raphson solver. The comparison of various network reconfiguration techniques are described with respect to power loss and reliability index levels. Finally, the optimal reconfigured network is selected among difference cases based on the two factors: the most reliable network and the least loss minimization.

Keywords—Distribution system reliability, loss reduction, network reconfiguration, reliability enhancement, reliability indices.

I. INTRODUCTION

AS the demand for electricity is increasing day by day, the power sector (both transmission and distribution) is being operated under overload conditions at most of the time. There is no customer who does not like to continuous supply electricity as economically and reliably as possible. The customers also expect that electric power should be available all the time (24 hours a day and 7 days a week) without any interruption [1]. Due to these reasons, the distribution system reliability plays a vital role to satisfy the customer's satisfactory without outage and with fewer losses. Therefore, maintaining the reliable power supply is a very important issue for power system design and operation.

In general, the reliability designates the ability of a system to perform its assigned function. Reliability of the power system refers to the probability of a system performing its function adequately for a specified period of time under the operating conditions without failure [2]. Several indices have been developed to evaluate the distribution system reliability and assess the future reliability of the network.

Several reliability improvement strategies [3], [4] have been developed for distribution system. Some of them are as follows: installation of DG, capacitor placement in distribution network, addition of protection devices, reclosing and switching, automation, fast fault prediction techniques, fewer

equipment failures to prevent contingencies and system reconfiguration [3].

Distribution network reconfiguration is one of the most significant strategies among the reliability improvement scheme. Distribution system reconfiguration is implemented by changing the status of switches (N/O tie switches and N/C sectionalizing switches) which exist between the main feeders and lateral sections [4]. Under normal operating conditions, distribution feeders may be frequently reconfigured by opening and closing switches to improve system reliability, increase voltage profile and reduce line losses.

The paper mainly focused on analyzing and evaluating the reliability and power loss in order to improve the reliability of practical distribution system but not for analyzing in terms of the interruption cost in case of power failure. The reliability evaluation was based on the direct mathematical solution using analytical method and the Power Toolbox [5] is applied to calculate the total line losses of case study network.

The structure of the paper is described as follows: Section II describes the conceptual of distribution system reliability and its assessment. Section III dedicates to the evaluation of distribution system reliability through network reconfiguration. The case study network and its description are illustrated in Section IV. The analytical results of different case studies are discussed in Section V. Finally, Section VI draws the conclusion.

II. DISTRIBUTION SYSTEM RELIABILITY

Reliability of distribution system is an important issue in power engineering for both utilities and customers. Reliability indices of an industrial distribution system are functions of factors such as component failures, repairs and restoration time which are random by nature [6]. It can also be described by probability distribution. The probability distributions associated with the reliability indices are very useful and conventional reliability analysis is normally concerned with these values.

A. Distribution System Reliability Concept

The system reliability depends not only on the reliabilities of components in the system but also on the dependencies among them [1]. The basic function of the power system is to provide an adequate electrical supply to its customers.

B. Distribution System Reliability Assessment

Reliability assessment tools allow system planners to assess

the reliability of service in terms of indices like frequency and duration of outages a customer experiences. It can be categorized into two ways to evaluate distribution reliability:

- (1) Historical reliability evaluation, and
- (2) Predictive reliability evaluation.

The former is used to assess the past performance of the system and the second one is used to forecast the system indices through the use of mathematical models to evaluate the behavior of the system in response to various failures that can occur [7]. The reliability indices are calculated based on historical data with respect to their failure rate and repair characteristics of various components with distribution network topologies.

III. RELIABILITY EVALUATION

The reliability evaluation of distribution system can be classified into two categories: deterministic and probabilistic techniques. The evaluation of power system reliability starts by creating a mathematical model of a system or subsystem. The probabilistic techniques can be subdivided into two methods; analytical method and numerical simulation method [8]. The analytical approach considers a reliability index as the sum of contribution from failures of individual components during a course of a year.

A. Reliability Enhancement Based on Network Reconfiguration

Reliability is an inherent characteristic and a specific measure of any component, device or system which describes its ability to perform the intended function. The reliability indices are used to measure the system reliability for assessing how well the system performs its basic function of supplying electrical energy to its customer [9], [10]. Reliability indices can be placed into two categories, basic load point indices and system performance indices.

B. Load Point Indices

The reliability indices such as load point indices and system indices are described as follows which are adapted from IEEE standard guide for reliability studies [11].

- 1) Average Failure Rate (λ)

$$\lambda_p = \sum_{i=1}^n \lambda_i \quad (1)$$

- 2) Annual Outage Time (U)

$$U_p = \sum_{i=1}^n \lambda_i r_i \quad (2)$$

- 3) Average Outage Duration (r)

$$r_p = \frac{U_p}{\lambda_p} = \frac{\sum_{i=1}^n \lambda_i r_i}{\sum_{i=1}^n \lambda_i} \quad (3)$$

C. Customer Oriented Reliability Indices

The system reliability indices can be calculated based on

the three fundamental indices mentioned above. There are many system reliability indices and commonly used system indices are presented as follows with their respective definition. These indices are used to assess the over system reliability.

- 1) System Average Interruption Frequency Index (SAIFI)

This is a measure of the average duration of interruption experienced by the system.

$$SAIFI = \frac{\sum \text{Total Number of Customer Interrupted}}{\sum \text{Total Number of Customer Served}} = \frac{\sum \lambda_i N_i}{\sum N_i} \quad (4)$$

- 2) System Average Interruption Duration Index (SAIDI)

SAIDI specifies the total duration of interruption for the average customer during a predefined period of time, which is commonly measured by hr/customer_yr

$$SAIDI = \frac{\sum \text{Customer Interruption Durations}}{\sum \text{Total Number of Customer Served}} = \frac{\sum U_i N_i}{\sum N_i} \quad (5)$$

- 3) Customer Average Interruption Duration Index (CAIDI)

CAIDI is defined as the ratio of customer interruption durations to total number of interrupted customers and its measurement is hr/customer interruption.

$$CAIDI = \frac{\text{Sum of Customer Interruption Durations}}{\text{Total Number of Interrupted Customers}} \quad (6)$$

- 4) Average Service Availability Index (ASAI)

ASAI refers to a customer received power during the defined reporting period.

$$ASAI = 1 - \frac{SAIDI}{8760} \quad (7)$$

- 5) Average Service Unavailability Index (ASUI)

$$ASUI = 1 - ASAI \quad (8)$$

D. Step by Step Procedure

The procedure of the mathematical formulation to evaluate the system reliability and power losses for changing network is as follows:

- Step1. *System reliability analysis*: characterizes the system and obtains the system data, component reliability data to evaluate critical components affecting system reliability.
- Step2. *Effect of reconfiguration on system reliability*: analyses the components in details and calculateS the effect of each component for system reliability with the appropriate input data for alternate configuration.
- Step3. *System Reliability level and loss minimization*: compareS the result of reliability level for initial and new configuration.

IV. CASE STUDY NETWORK

Pyigyitagon Industrial Zone (I) is taken as the test case for the practical distribution system from Tagondaing Substation.

The one line diagram for practical distribution system of Pyigyitagon Industrial Zone (I) is shown in Fig. 1.

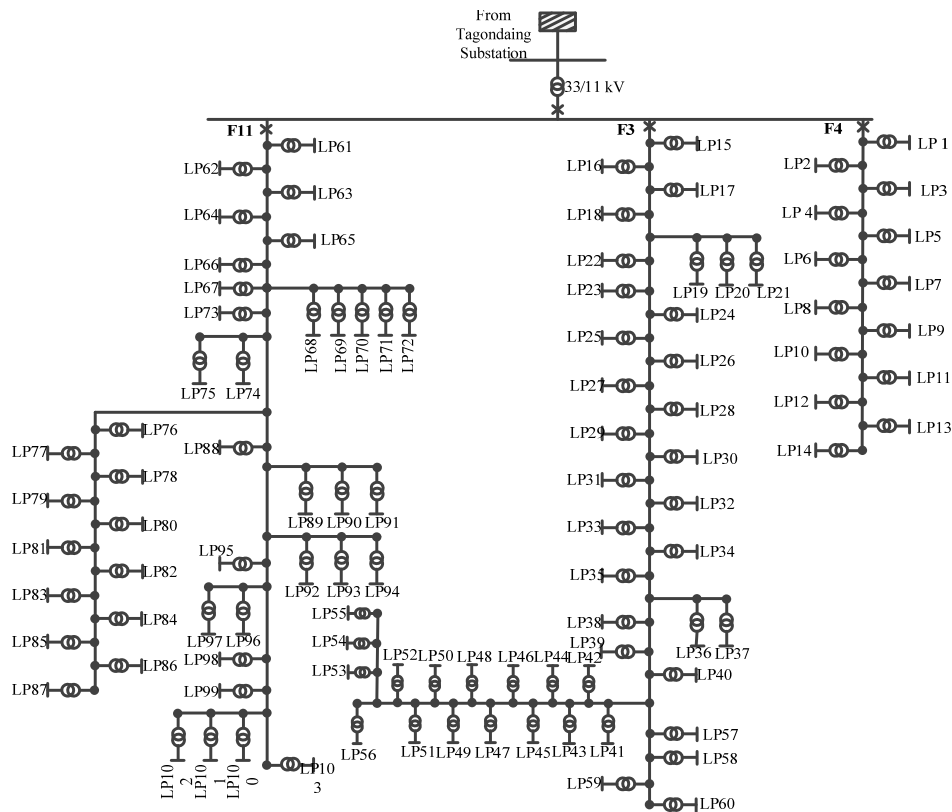

Fig. 1 Distribution System for Industrial Zone (1)

To evaluate the reliability and line losses for proposed distribution network, a practical 115-bus industrial distribution network is used. This industrial distribution system is extracted from 33/11 kV Tagondaing substation in Mandalay area, Myanmar [12].

A. Network Description

The single line diagram of industrial distribution networks consists of three main feeders mainly - F1, F3, F11. The voltage levels of this system are 33 kV and 11 kV and incoming lines are 33 kV and then they distribute 11/0.415 kV to the customers. The rated capacity of this distribution system is 10 MVA. In the design of practical distribution network, it has four types of customers including residential, commercial, government/institution and small user. The total number of customers is 5295 [12]. These loads are metered on the low voltage sides.

B. System Data

The required data and information for the period of one year from June 2017 to June 2018 were collected from MESC data [12]. The requirement data for distribution system reliability parameters such as failure rates, repair times and switching times for transformers, breakers and lines are given in Table I. This table includes the data to perform the basic analysis of the system such as effects of outages on 11 line system,

temporary failures, maintenance effects, etc. In this paper, the reliability levels of fuses and disconnects are assumed to be 100% reliable, i.e., it has been assumed that the substation is fully reliable.

In this paper, the total number of outages is collected chronologically month by month in order to compute the failure rate of lines. To get an estimate of average number of failure/km-year, the data collection is done on the respective overhead line circuit length in km. The sectionalized failure rate of each feeder can be evaluated by multiplying the main section length (km) and lateral section length (km) with average failure rate (failure/km-year). Then, the failure rate of the individual load point can also be calculated by summing of failure rate of main section, lateral section and transformer.

TABLE I
 PRACTICAL DISTRIBUTION SYSTEM RELIABILITY PARAMETERS

Components	Total failure rate, λ_t (f/yr.km)	Active failure rate, λ_A (f/yr.km)	Repair time, r (hr)	Switching time, s (hr)
Transformer (11/0.415 kV)	0.015	0.015	200	1
Breakers (11 kV)	0.006	0.004	4	1
Line (11 kV)	0.0997	0.0997	10	1

The average repair time is determined by estimating the average of the time that it took to repair each of sustained faults during the period of interest. In this table, the ratings of

breakers and transformers are taken from [13] while the failure rates of transformers are supported by MESC [12].

V. RESULTS AND DISCUSSION

The system reliability indices SAIFI, SAIDI, CAIDI, ASAI and ASUI can be calculated based on load point indices and also the power losses for five different cases are estimated. The five different cases are presented as follows:

- Case 1: Base case (no tie line and tie switch)
- Case 2: Considering the tie line in between 14-113
- Case 3: Considering the tie line in between 14-64
- Case 4: Considering the tie line in between 64-113
- Case 5: Considering the combination of the tie lines 14-113, 14-64, 64-113

A. Base Case Load Flow Result and Reliability Indices Calculation

Base case load flow is performed by using Newton-Raphson power flow solver and is implemented in MATLAB R2014a. The base case load flow results for active power and reactive power with their respective rated power, total load and total losses of initial network are obtained at third iteration with maximum power mismatch of 0.0000511431. The finalized total power losses of initial configuration for the industrial distribution system are obtained 0.983 MW and 0.611 Mvar. Total rated power is 7.59 MW while the total load is 6.667 MW. It can be observed that the percentage of real power loss is 12.16 % in the base case network.

Equations (9) and (10) are applied to calculate the basic load point indices for initial distribution network [14]. The system performance indices are evaluated with the help of basic load point indices by using (4)-(8):

$$\lambda_i = \lambda_{cb}^p + \sum_{m=1}^i \lambda_m + \lambda_{ti} + \lambda_{li} \quad (9)$$

$$U_i = \lambda_{cb}^p \times r_{cb} + \sum_{m=1}^i \lambda_m \times r_m + \left[\sum_{m=i+1}^i \lambda_m \times t_s \right] + \lambda_{ti} \times r_{ti} + \lambda_{li} \times r_{li} \quad (10)$$

These resultant indices for base case system are listed in Table II. In Table II, the column refers to the results of system indices (SAIFI, SAIDI, CAIDI, ASAI, ASUI) for each feeder and the last row is the overall system reliability indices for basic radial distribution system.

TABLE II
 SYSTEM INDEX CALCULATION OF BASIC RADIAL SYSTEM

Feeder No.	SAIFI	SAIDI	CAIDI	ASAI	ASUI
F1	0.2092	4.1875	20.019	0.999522	0.000478
F3	0.6635	6.8474	10.320	0.999218	0.000782
F11	0.6704	6.7386	10.052	0.999231	0.000769
System	0.6073	6.4672	10.650	0.999262	0.000738

The system indices ASAI and ASUI for base case are presented with the relevant bar chart as shown in Figs. 2 and 3. ASAI is linearly related to SAIDI because ASAI can be

represented in relation to SAIDI, as expressed in (7) and it is a reliability index commonly used by electric power utilities. Minimization of interruption duration can increase the system service index ASAI. ASUI is the complement of ASAI.

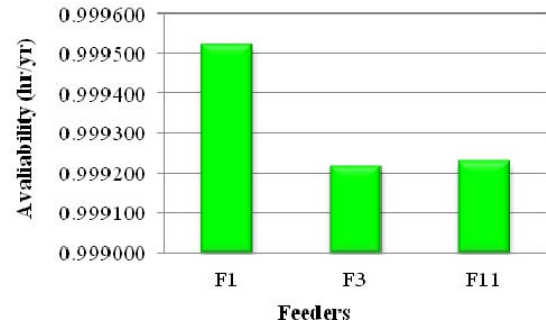

Fig. 2 ASAI Index for Base Case

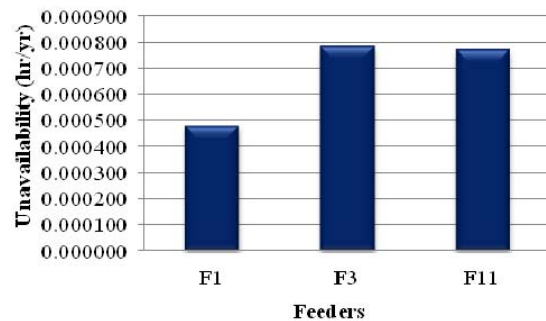

Fig. 3 ASUI Index for Base Case

The overall system reliability indices for initial network are also described with the bar chart as shown in Fig. 4.

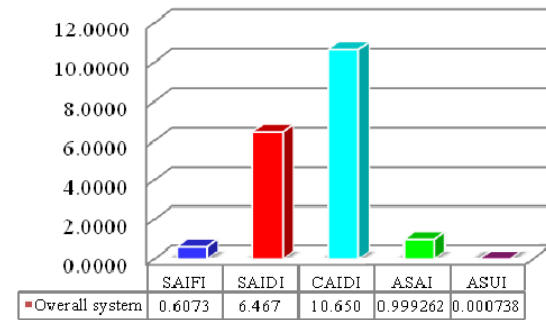

Fig. 4 Overall System Reliability Indices before Network Reconfiguration

In Figs. 3 and 4, base case reliability indices for each feeder and overall system are illustrated. The values of ASUI for each feeder are illustrated in Fig. 3 while overall indices are demonstrated in Fig. 4. Observing on these data (Table II) and figures, it can be predicted whether the distribution system is reliable service or not in the future.

B. Reconfigured Network on Four Different Case Studies

The one line diagram after network reconfiguration is expressed in Fig. 5. This distribution network consists of 3 feeders with 103 total load points and 3 tie lines that consist of

normally closed circuit breakers. The tie lines are in between 14-64, 14-113, 64-113. These tie lines are considered based on

the voltage difference level between two sides of the feeders as well as the low voltage profiles in respective nodes.

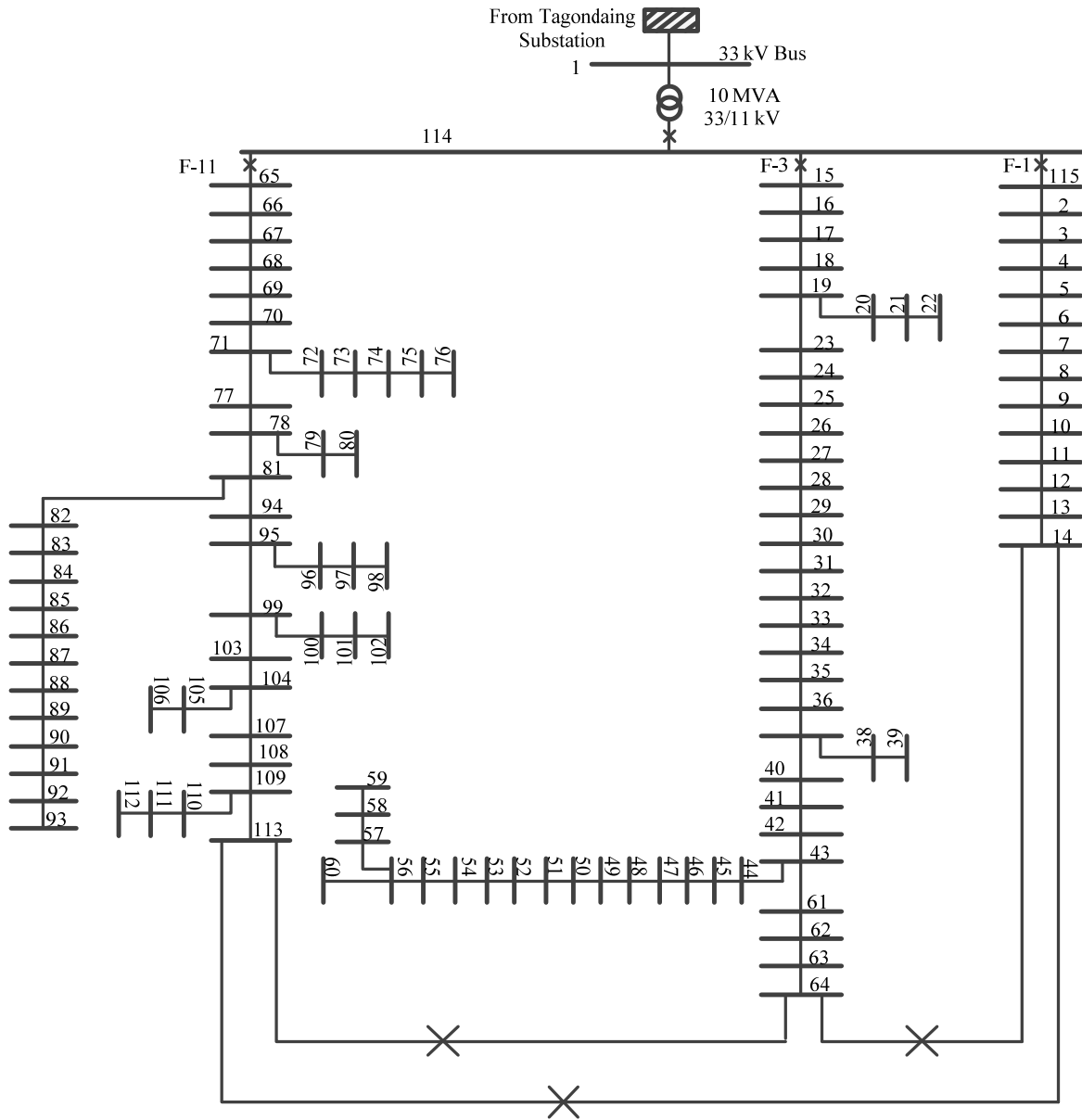

Fig. 5 Reconfigured Industrial Distribution Zone (1)

The four different cases for reconfigured network (Case 2 to Case 5 mentioned earlier) are examined for system reliability and loss reduction of the industrial distribution network. The network configuration of various cases for loss reduction is attained by utilizing the Newton-Raphson power flow solver to implement the load flow estimation. The real power loss can also be reduced significantly through respectable network reconfiguration. The reliability parameters are evaluated for all these four cases. To calculate these parameters, it is needed to calculate the basic load point indices that are failure rate, repair time and annual outage time. The optimal reconfigured network is chosen among these four case study configured network with the objective of minimizing failure indices and

reducing the total line losses.

Table III describes the results of the power loss for active and reactive power and also the percentage loss with different cases. In this table, base case information is not expressed. For base case solution, the average load demand is 6.667 MW [12] and after evaluating load flow solution, the active power loss is 0.985 MW and the reactive power loss is 0.611 Mvar. The percentage of real power loss is 12.16% based on average load. It can be seen from Table III that the active power loss reduced form 0.985 MW to 0.611 MW after network reconfiguration and the final network configuration is demonstrated in Fig. 5. The results of total power losses for four different cases are organized in Table III. All these

reconfiguration cases for loss reduction are attained after three iterations by applying the Newton-Raphson solver.

TABLE III
NETWORK RECONFIGURATION FOR INDUSTRIAL DISTRIBUTION SYSTEM

Case	Real Power Loss (MW)	Reactive Power Loss (Mvar)	% Loss
2	0.929	0.585	11.54
3	0.831	0.497	10.83
4	0.615	0.381	8.37
5	0.611	0.380	8.32

Although the network topology is changed, the total load demands do not change for all cases. Comparing the results of the first state and last state, it can be seen that the active power loss can be reduced from 0.929 MW to 0.611 MW and reactive power loss can be reduced from 0.585 Mvar to 0.380 Mvar. It can be observed that the final stage (reconfigured network) represents about 37% in real power loss reduction comparing with base case solution. In that stage, the system is considered as fully meshed and reconfigured system as described in Fig. 5. Fig. 6 shows the comparison of total active and reactive power loss for five types of different cases.

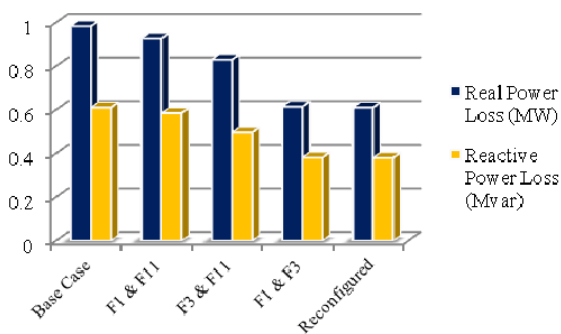

Fig. 6 Total Losses for Five Types of Different Cases

Fig. 6 shows the comparison of total active and reactive power loss for five types of different cases. It can be detected that the total power losses are reduced when the network configuration is changed by adding the tie lines between two feeders.

In order to evaluate the load point indices for reconfigured network, the following equations are used [13]:

$$\lambda_i = \sum_{m=1}^i \lambda_m + \lambda_{ti} + \lambda_{li} \quad (11)$$

$$U_i = \sum_{m=1}^i \lambda_m \times t_s + \lambda_{ti} \times r_{ti} + \lambda_{li} \times r_{li} \quad (12)$$

The interruption frequency for a customer can be evaluated by summing the failure rates of all the main sections, plus the failure rate of transformer and lateral section. The failure rate of a section depends on the type of construction, length of exposure, number of customers and other component outages rate.

The annual outage times can be calculated by multiplying

failure rate and repair time but main section used switching time instead of repair time because of alternate supply. After calculating the basic load point indices, the system performance indices can be evaluated with the help of these indices. The system indices of the five different cases (including base case and four different reconfigured network case studies) are summarized in Table IV. The different cases with their reliability level and comparison of these levels with respect to their network topology are also shown in Fig. 7.

TABLE IV
EFFECT OF RECONFIGURATION FOR INDUSTRIAL DISTRIBUTION SYSTEM ON SAIFI, SAIDI, CAIDI, ASAI AND ASUI

Case Studies	SAIFI	SAIDI	CAIDI	ASAI	ASUI
F1 and F11 (14-113) with tie line and F3 is radial	0.6063	5.4469	8.984	0.999378	0.000622
F1 and F3 (14-64) with tie line and F11 is radial	0.6059	4.8685	8.035	0.999444	0.000556
F3 and F11 (64-113) with tie line and F1 is radial	0.6055	4.0093	6.621	0.999542	0.000458
Reconfigured network	0.6053	3.9287	6.491	0.999552	0.000448

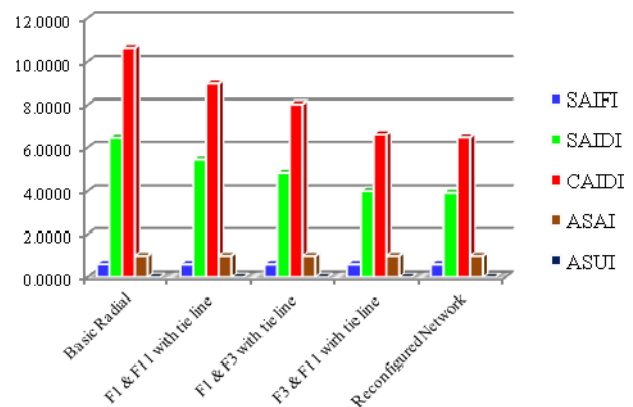

Fig. 7 Effect of Network Reconfiguration on System Reliability Indices

The changes of the overall system reliability indices due to network reconfiguration are presented in Table IV. The following are discussed about the different cases by changing network topology so that to improve the system reliability and to reduce the system power losses.

Case 1: The overall system reliability indices are 0.6063, 5.4469, 8.984, 0.999378 and 0.000622 respectively whereas the real power loss and reactive power loss are 0.929 MW and 0.585 Mvar at the percentage loss 11.54%. It is more available service than base case.

Case 2: The system indices of Case 3 are 0.6059, 4.8685, 8.035, 0.999444 and 0.000556 respectively. The total losses are 0.615 MW and 0.381 Mvar at the percentage loss is 8.37%. The service is available because of the less interruption duration.

Case 3: The system indices of Case 3 are 0.6059, 4.8685, 8.035, 0.999444 and 0.000556 respectively. The total losses are 0.615 MW and 0.381 Mvar at the percentage loss is 8.37%. The service is available because of the less interruption duration.

Case 4: In this case, the network is completely reconfigured as

shown in Fig. 5. Therefore, it can be observed by comparing the results of other cases that the service available of the whole distribution system reliability is greatly increased by providing the alternative supply in each feeder. And the percentage of loss is also minimized from 12.16 % to 8.32 %.

C. Comparison of System Reliability and Loss Minimization for Different Cases

Comparing the reliability parameters and power losses of five cases are summarized based on various results.

- The reliability parameters and power losses were calculated on different five cases tested on practical distribution network (Pyigyitagon Industrial Zone (I)).
- The last case study (considering all tie-line connection) is the best network configuration among the all other cases. Therefore, it is the more reliable network and also losses are minimized than that of Case 4 (tie-line connection between 64 and 113).
- The networks in Case 3 (tie-line connection between 14 and 64) and Case 4 have alternative supplies (tie-line connections) to restore service if the outages occur in any section along feeder. It can be said that although Case 4 is more available service and better reliability indices than that of the Case 3, the power loss reduction is less reduced than the Case 3.

VI. CONCLUSION

This paper focused on the reliability improvement of distribution system as well as system loss minimization using network reconfiguration techniques. The mathematical formulation is used to evaluate the changes in system reliability indices through network reconfiguration. For the system reliability, different cases are compared and determined based on the system reliability indices considering tie line connections at the system voltage weak nodes. It was observed that the reliability indices and power losses vary depending on network reconfiguration, geography and weather conditions. The best network reconfiguration techniques based on their topology can vary the reliability level, improve the overall system reliability indices in the network and reduce the power losses in the system. Therefore, it can be confirmed that the last case (considering all tie-line connection) is the best network configuration comparing the other cases with highest reliability indices and least active power losses. In conclusion, the technique for network reconfiguration focusing on network topologies and tie-line connection can enhance the system reliability improvement as well as the reduction in power losses.

REFERENCES

- [1] Billinton R., and Allan R.N., *Reliability Evaluation of Power System*, Plenum Publishing, New York, 2nd Edition, 1996.
- [2] Billinton, R., "Distribution System Reliability Performance and Evaluation", *Electrical Power and Energy System*, vol.10, no.3, July, 1988.
- [3] A.H. Etemadi, M. Fotuhi-Firuzabad, "Distribution System Reliability Enhancement using Optimal Capacitor Placement", *IET Gener. Transm. Distrib.* vol. 2, no. 5, 2008, pp. 621–631.
- [4] P. Pavani, S N Singh, "Reconfiguration of Radial Distribution Networks

- with Distributed Generation for Reliability Improvement and Loss Minimization", *2013 IEEE Power & Energy Society General Meeting*, Vancouver, BC 2013.
- [5] Hadi Saadat, *Power System Analysis*, McGraw-Hill, New York, 2nd Edition, 2004.
- [6] T. Lantharhong, N. Phanthuna, "Techniques for Reliability Evaluation in Distribution System Planning", *International Journal of Electrical and Computer Engineering*, vol.6, no.6, 2012.
- [7] Sree Rama Kumar Yeddnapudi, et al., "Development Predictive Reliability Assessment Tool for Distribution Systems", *IEEE 37th Annual North American Power Symposium*, IA, USA, Oct. 23-25, 2005.
- [8] R. Billinton, P. Wang, "Reliability Network Equivalent Approach to Distribution System Reliability Evaluation", *IEE Proc.-Cener. Transm. Distrib.*, vol. 145, no. 2, March, 1998, pp.149-153.
- [9] Li-Hui Tsai, "Network Reconfiguration to Enhance Reliability of Electric Distribution Systems", *Electric Power Systems Research*, vol. 27, Issue.2, 1993, pp.135-140.
- [10] Abdollah K. F., Mohammad-Reza A. Z., "Reliability Enhancement using Optimal Distribution Feeder Reconfiguration", *Neurocomputing*, vol.106, no. 4, 2013, pp.1-11.
- [11] IEEE, 2004, *Guide for Electric Power Distribution Reliability Indices*, Standard 1366-2003, May-14.
- [12] MESC, *Pyigyitagon Township Distribution Network Data*, Mandalay Area, 2018.
- [13] R.N. Allan, R. Billinton, I. Sjarief, L. Goel, K.S. So, "A Reliability Test System for Educational Purposes- Basic Distribution System Data and Results," *IEEE Transactions on Power System*, vol.6, no.2, May, 1991, pp.813-820.