

A Semi-Automatic Mechanism Used in the Peritoneal Dialysis Connection

I-En Lin, Feng-Jung Yang

Abstract—In addition to kidney transplant, renal replacement therapy involves hemodialysis and peritoneal dialysis (PD). PD possesses advantages such as maintaining stable physiological blood status and blood pressure, alleviating anemia, and improving mobility, which make it an ideal method for at-home dialysis treatment. However, potential danger still exists despite the numerous advantages of PD, particularly when patients require dialysis exchange four to five times a day, during which improper operation can easily lead to peritonitis. The process of draining and filling is called an exchange and takes about 30 to 40 minutes. Connecting the transfer set requires sterile technique. Transfer set may require a new cap each time that it disconnects from the bag after an exchange. There are many chances to get infection due to unsafe behavior (ex: hand tremor, poor eyesight and weakness, cap fall-down). The proposed semi-automatic connection mechanism used in the PD can greatly reduce infection chances. This light-weight connection device is portable. The device also does not require using throughout the entire process. It is capable of significantly improving quality of life. Therefore, it is very promising to adopt in home care application.

Keywords—Automatic connection, catheter, glomerulonephritis, peritoneal dialysis.

I. INTRODUCTION

KIDNEY dialysis is a great health care expenditure. According to statistics from Taiwan's National Health Insurance Administration, 83,808 outpatients requiring dialysis were recorded in 2015 with a total emergency expenditure of approximately US\$ 1.88 billion [1]; on average, each of these patients spent US\$ 20,000 a year, which is 30 times that of the average person. Thus, kidney dialysis is a great health care expenditure. Furthermore, patients with diabetes are among the high-frequency dialysis population; vision loss is the main problem associated with infection from at-home PD. This is because of patients' incapacity to precisely hold their catheter, causing the connector to be touched or dropped on the floor during PD, resulting in fatal infection [2]. Clinical statistics indicate that this occurs more than once in at least six years. Therefore, the provision of an automatic connection mechanism is urgent for solving the infection problems of patients receiving at-home PD.

There are two common treatments in kidney dialysis: hemodialysis and PD. Patients who receive hemodialysis must visit the hospital two to three times a week for treatment, with each hemodialysis requiring four to six hours, which is a

time-and energy-consuming affair for working people. PD includes continuous ambulatory PD (CAPD) and automated PD (APD); hereafter, PD collectively refers to both types of dialysis. Patients who opt for PD can perform it at home and are required to return to the hospital once a month. Compared with hemodialysis, PD has fewer restrictions on patients, although its disadvantage is the possibility of bacteria and viruses being mixed into the dialysate during exchanges. This leads to the risk of peritonitis, which can be prevented by maintaining satisfactory hygiene. Hygiene problems for hemodialysis are handled by doctors and nurses and are the reason why PD has a higher early mortality rate.

There are several advantages in using PD: stable blood pressure, good mobility, and possibility in home-care. In addition, because of its lower cost than hemodialysis, the Department of Health of the Executive Yuan, Republic of China included PD as a program to promote for dialysis medical policies in 2006. There are also disadvantages of PD which need to be resolved. These include (1) dialysis exchange 3~5 times a day, (2) peritonitis occurred if improper operation is taken [3]. Thus, dialysis exchange operating techniques have received much attention. According to Chiang and Huang, improper exchange operation and the lack of sterile concepts account for the major causes of peritonitis, with catheter replacement accounting for approximately 70%. Patients receiving PD must undergo exchange four to five times a day for approximately 30–40 minutes per session without professional medical care personnel at home or any place of exchange. Patients undergoing dialysis are at the end-stage of renal failure, which leads to complications such as hand weakness, trembling, and vision deterioration. Patients inadvertently touching the catheter outlet or dropping the catheter on the floor are the most likely causes of infections such as peritonitis, and thus, they must be avoided. Therefore, this study proposed a semiautomatic and miniaturized auxiliary device that can solve the possible problems of infection in exchange operation. The steps that may be infected are subjected to machine connection for automated connection of the catheter, thereby replacing the manual connection approach using machine automation to reduce the chances of peritonitis. Through the use of such devices, the patients can achieve the goals of home-based care, reduced frequency of outpatient visits, reduced peritonitis, and improved life quality.

II. CONNECTION SEQUENCE IN PD

The catheter for the fluid connection of the dialysis machine requires an "aseptic connection device" (i.e., a connector). First, the waste is drained from the patients' bodies, and the

En Lin is with the National Formosa University, Yu-Lin, Taiwan (phone: 886-5-6315424; fax: 886-5-6312110; e-mail: samlin@nfu.edu.tw).

Feng-Jung Yang is with the Department of Neurology, National Taiwan University Hospital Yunlin Branch, Yu-Lin, Taiwan (e-mail: fongrong@gmail.com).

required liquid is then filled in after cleaning as seen in Fig. 1 (A) [4]; thus, the aseptic connection device is both necessary and crucial. The device must ensure the sterile isolation of the fluid connection from the outside environment. Before the connection is made, contamination may occur during the connection and disconnection of the insulation on the contact surface of the catheter; hence, the current trend is for an integrated design approach [5]. The dialysis machine manufacturer with the current highest market share is Baxter Healthcare SA. The tightness and conduction designs of the connector in its patented dialysis devices are integrated as shown in Fig. 1 (B) [6], enabling users to complete actions such as connection, conduction, and closing with one hand. In addition, a disposal cap can tightly lock the connector, making the device less susceptible to infection when not in use.

In 2007, Connell et al. [5] designed a new connector that combined a disinfectant with the connector cap, enabling patients to close the cap after dialysis without touching the connector, thereby reducing the incidence of bacterial infection. When patients undergo dialysis, the patient-end and medicine bag-end terminals must be connected, after which the switch is turned on to enable the dialysis fluid to enter the abdominal cavity. This design adds a sterilizing sleeve at the outlet of the medicine bag-end terminal, with the sleeve and the medicine bag being connected, and patients must open the connector cap before use to begin the fluid exchange operation.

In 2012, Katsuyoshi et al. [7] and Childers [8] designed a PD patient connection system that uses gears to drive the connection and disconnection of the catheters in the body. The patient-end and medicine bag-end terminals are inserted respectively from two directions, and the gears rotate the patient-end terminal to the same position with its medicine bag-end counterpart after the cap is unplugged, combining them to commence the dialysis treatment. After the treatment is completed, the cap is closed in accordance with the same principle. The focus of this design is that patients do not touch the connectors, which avoids bacterial infection. The design concept of this system can significantly reduce the chances of patient infection, although the patients cannot leave the device

and must wait nearby throughout the whole procedure. Another disadvantage is that the disinfection cap in Fig. 1 (A) is not automatically retrieved following the automatic cutting of its packaging. Instead, it is unpacked and retrieved manually, after which it is placed into the system for operation. Risks such as dropping it on the floor or accidentally touching it can be minimized through automated mechanisms.

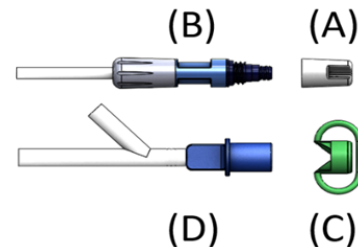

Fig. 1 (A) is the disinfection cap on the patients' connector; (B) is the fistula connector preinstalled on the patient (hereafter referred to as the patient-end terminal); (C) is the elastomeric rubber sleeve that connects the medicine bag-end terminal with its patient-end counterpart; and (D) is the connector on the dialysate (hereafter referred to as the medicine bag-end terminal). Patients must connect the ends for the patient-end and medicine bag-end terminals through manual rotation to form a closed circuit between the medicine bag and abdominal cavity for exchange

In the early stage of this study, the appearance of the PD connector by Baxter with higher market share was used as the target vehicle to develop an automated connection device for patients. The device used six small motors supplemented with a creative mechanism design, whereby the original seven manual steps were simplified into three, greatly reducing the chances of infection caused by patient contact with the fluid and device (Table I). The manual steps enabled patients to remove the catheter and move freely within the permitted range of the medicine bag-end machine. The concept of this innovative design can be transferred to other types of connectors in the future, thereby achieving the dual purposes of home-based operation by patients and simple maintenance of equipment.

TABLE I
 STEP ANALYSIS AND AUTOMATION INSTRUCTIONS

Step	descriptions	Original Baxter's Standard operation procedure	actions	time (sec)	buttons
1	Open the cap	Manual/Rotate	Automatic	10	
2	Lock the patient-end and medicine nag-end terminals	Manual/Linear Motion/Rotate	Automatic	10	1
3	Turn on the dialysis switch	Manual/ Rotate	Manual	5	manual
4	Turn off the dialysis switch	Manual/ Rotate	Manual	5	manual
5	Loosen the patient-end and medicine bag-end terminals	Manual/Linear Motion Turn/Rotate	Automatic	10	2
6	Replace disinfection cap (remove from sterile packaging)	Manual/Spatial Movement/Rotate	Automatic	12	3
7	Lock the patient-end and medicine-end terminals	Manual/Rotate	Automatic	12	

III. DEVELOPING MECHANISM

A. Device Requirements

Because of its short length (less than 30 cm), the fistula (the catheter connected to the patient-end terminal) could be placed between the patient and dialysis machine (roughly 10–15 cm

from the patient) and be operated when lying down. Therefore, the device had to be miniaturized (approximately 30 cm²) and lightweight (less than 7 kg or lighter). During the "rotation" operation when connecting the patient-end and medicine bag-end terminals, the fistula at the "patient-end terminal" should not rotate and must remain constant to reduce the

possibility of accidental injury. After commencing liquid transfer following connection, patients had to be able to move freely away from the device without the need to remain beside it, and their disinfection caps replaced with a new one each time to reduce infection. In addition, the device had to be powered by a 110 V household voltage or battery.

The torque required for the “rotation” (including screwing and unscrewing) during the connection was crucial. Fig. 3 shows the “torque–rotation” data measured from the screwing and unscrewing of the connectors for the “disinfection cap” and “patient-end terminal.” Using the gripper jaw and torque wrench for screwing (unscrewing) during the measurement can reduce the influencing factors of experimental errors, and the maximum torque was approximately 0.3 N-m. The torque required for the Stepping motor used in the device was

$$\sum T_{motor} = T_L + B \cdot \omega \cdot r + J \cdot \frac{d(\omega r)}{dt} \quad (1)$$

where T_L is the required torque (taken from the maximum value in experimental measurements) for the load to start moving from a stationary state, and ω and r are angular velocity and rotation radius, respectively. The magnitudes of J (rotational inertia) and B (rotational friction torque) produced depend on the type of load and movement speed, forming dynamic changes according to the movement speed of the load; thus, they must be considered and calculated using the maximum value. GD^2 was determined as the inertia value of mechanical motion (G represents the object weight, and D represents the rotation diameter), and was often used to replace I (moment of inertia) in the design of servo motors. A Stepping motor was used for the mechanism, and its design used $J = g \cdot I$ as the

moment of rotational inertia. Based on the motor used by the designed mechanism, the conversion of the two approaches are as follows:

$$I(kgf \cdot cm \cdot s^2) = \frac{I(kgf \cdot cm^2)}{g(\frac{cm}{s^2})} = \frac{GD^2(kgf \cdot cm^2)}{4g(\frac{cm}{s^2})} \quad (2)$$

The motor shaft, gripper jaw, and carrying platform for the device were driven through gear sets and pulleys. When using multiple interlocked rotors (e.g. m times reduction gears), GD^2 can be calculated as follows (n_i is number of tooth in the i th gears):

$$GD^2 = \sum_{i=0}^m GD_i^2 \left(\frac{n_i}{n_0}\right)^2 \quad (3)$$

B. Mechanism Control and Process

The mechanism used a single chip to control the motor, sensing device, and mechanism movement. The overall mechanism was divided into a (1) single-chip main control unit; (2) an aseptic package autocutting unit as shown in Fig. 2 (No.1); (3) a planar (X–Y) movement unit that controlled the gripper jaw in Fig. 2 (No.2); (4) gripper jaw rotation and holding fixture unit in Fig. 2 (No.3A); and (5) docking and disconnection units of the two catheters in Fig. 2 (No.3B). The four units had corresponding sensing devices that transmitted feedback signals to the main control unit to ensure the completion of the actions. Because the holding fixture used in conjunction with the components in Fig. 1 had a complex curved surface, 3D printing technology was used as a substitute for the conventional mechanical processing approach in its implementation.

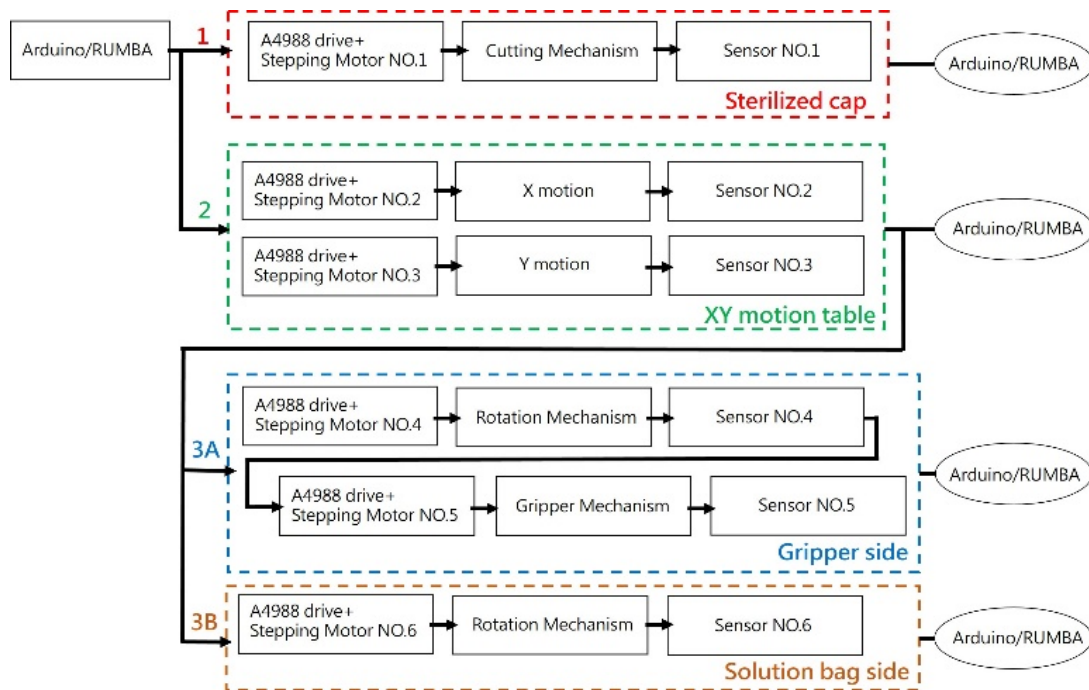

Fig. 2 Single-chip control circuit configuration

The main control unit used an Arduino/RUMBA (Reprap Universal Mega Board with Allegro driver) for controlling Fig. 4, whereas Arduino C language was adopted for programming. Program codes were compiled to process more distinct and complex action instructions. A light-emitting diode display module was added to the control unit to enable patients to understand the action sequences currently executed by the machine.

Fig. 2 (No. 1) illustrates that the disinfection cap shown in Fig. 1 (A) automatically extracted the unit from the aseptic package. A foolproof mechanism for selecting direction was incorporated to ensure that the opening of the cap faced the gripper jaw; the mechanism was completed using a single motor to drive two gear sets (circular blade rotation and linear motion of the disinfection cap) in Fig. 3. After the aseptic package was cut open, the gripper jaw removed the cap and locked the patient-end terminal in Figs. 1 (A) and (B). Fig. 2 (No.2) shows the planar (X–Y) movement mechanism required for displacements, such as that of the gripper jaw to the catheter after removing the disinfection cap, as well as the posterior and anterior displacements for the connection and disconnection of the disinfection cap and medicine bag-end terminal. The main reasons for using the planar (X–Y) movement mechanism in this study were the weight of the device to be reduced, and that its volume would not exceed 30 cm as shown in Fig. 4. Fig. 2 (No.3A) shows the action mechanism for controlling the screwing and unscrewing of the patient-end terminal catheter by the gripper jaw when holding the disinfection cap. Because of safety considerations, the catheters at the patient-end terminal were stationary without any rotation; thus, Fig. 2 (No.3A) has a mechanism for gripper jaw rotation Fig. 5. Both ends of the patient-end and medicine bag-end terminals were docked by screwing (or unscrewing), and the main control is shown in Fig. 2 (No.3B) Figs. 1 (B) and (D). The patient-end terminal was fixed and did not rotate, whereas its corresponding medicine bag-end counterpart was screwed in through rotation (the rotation mechanism in Fig. 2 (No.3B)) for liquid conduction (or the unscrewing of both ends for disconnection). A total of six stepping motors formed four mechanism modules to execute the seven steps in Table I. The “manual” step in Table I enabled the patients to leave the auxiliary device and move freely within the permitted range at the medicine bag-end of the machine after removing the catheter themselves.

IV. MOTION AND FUNCTION VERIFICATION

A. Verification of the Aseptic Package Autocutting Unit

The two gear sets were driven by a single motor (simultaneous actions of circular blade rotation and linear movement of the disinfection cap) in Fig. 3. The number of rotations for the blades was matched by the number of cogs on the gear sets; hence, the number of rotations was set as 60 RPM. The linear movement speed was also achieved through two gears and one linear slide at a speed of 76 mm/sec. The sensors detected whether the linear displacement reached the designated position and transmitted the feedback to the main

control chip. Once the placement direction of the aseptic package and the carrier position were unchanged, the cutting of the aseptic package had a 0% failure rate.

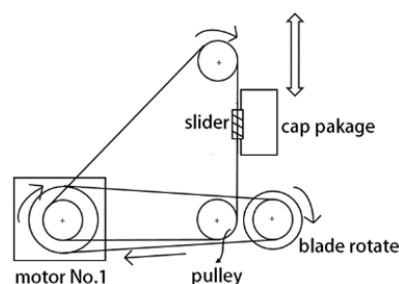

Fig. 3 Schematic for the aseptic package autocutting mechanism

B. Verification of the Planar (X–Y) Movement Unit Controlling the Gripper Jaw

Two Stepping motors controlled the planar displacement of the carrier platform, whereas two position measures detected whether the displacement reached the designated position; the signals were transmitted back to the main control chip as shown in Fig. 2. The shifting of motor rotation into a linear motion was achieved using ball screws, gears, or slides, with a current linear speed of 105 mm/sec.

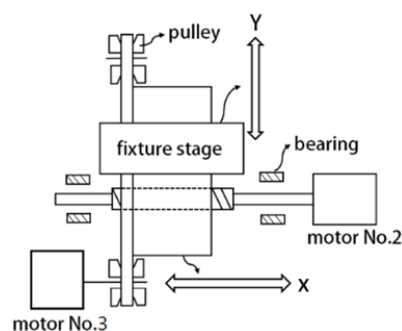

Fig. 4 Schematic for planar (X–Y) movement unit

C. Verification of Claw Rotation and the Holding Fixture Unit

The holding action of the gripper jaw was a one-dimensional linear “hold–release action” (holding and releasing the disinfection cap), which was achieved using an electric pneumatic cylinder and a sensor as shown in Fig. 5 (A). Because the gripper jaw was in direct contact with the outer diameter of the cap, a sufficient holding force was required to ensure that slipping would not occur during the action; thus, the contact area of the jaw and the outer diameter was the main consideration during selection and design. In addition, the torque required by the jaw was achieved by the motor through the reduction gear, and had to be measured in advance to ensure the actual screwing in and out of the connection device during the action.

D. Verification of the Docking and Disconnection Units for the Two Catheters

As shown in the previous mechanism description, the patient-end terminal was fixed and did not rotate, whereas its

corresponding medicine bag-end counterpart was screwed by rotation, which was achieved using a Stepping motor together with a sensor Fig. 5 (B). Because the key for screwing and unscrewing lies in the torque provided by the holding fixture for the catheters, a reduction gear was used to achieve a torque greater than 0.3 N-m. Because the holding fixture for the catheter and the catheter connector in Fig. 1 (D) relied on the wide range of surface irregularities in their contact area (achieved using 3D printing) instead of contact friction to transmit the torque, slipping did not occur during docking, see Figs. 1 (B) and (D). A foolproof mechanism was considered for placing the end of the catheter into the holding fixture, wherein if the end of the catheter (before and after the use of the device) could not be placed into the fixture without following the required appearance and direction, no follow-up action would occur. Fig. 6 shows the top view of this device with the removal of clear cover and parts for illustration purpose.

constraints on patients' activities. The proposed dialysis catheter connection mechanism used four action units and six Stepping motors to complete the seven processes of connection. The entire mechanism could complete the operation within a confined space, thereby effectively reducing the use processes and chances of bacterial attachment. Because the dialysis catheter connection mechanism was portable and did not require using throughout the entire process, it was capable of significantly improving quality of life. Clinical use verifications confirmed that the mechanism is operable and can achieve the design purposes of this study, and thus, the device has potential value for home application.

ACKNOWLEDGMENT

This work was partially funded by the Ministry of Science and Technology of Taiwan under grand MOST 106-2218-E-002-016. The authors would like to thank students Zheng-Xiang Yang, Bo-Han Lee, and Ming-San Zhang from National Formosa University for their experiment and mechanical design works.

REFERENCES

- [1] National Health Insurance Administration (2015). Information Disclosure Report on the Overall Medical Quality of Outpatient Dialysis.
- [2] Wu, M. C. Hemodialysis Room, Taipei Veterans General Hospital. How Much do you Know about Hemodialysis? <http://www.youth.com.tw/db/epaper/es002001/n980303-o.htm>. (accessed date:20180122).
- [3] Chiao-Yaung Lu Shu-Man Weng * Mei-Yueh Chiu, Shio-Chin Tseng Ya-Fang Yang Chiung-Yao Chen, Decreasing The Incidence Of Peritonitis In Peritoneal Dialysis Patients: By Improving the Recognition and Technique. Journal of Taiwan Nephrology Nurses Association, Vol. 9 Issue 1, June 2010.
- [4] Vlado Ivan Matkovich, Thomas J. Bormann, Gerard R. Delgiacco, Mladen Franovic, Connector Assemblies, Fluid Systems, and Methods for Making a Connection. Pall Corporation, US 6,655,655 B1, Dec. 2003.
- [5] Brian Connell, Bill Griswold, Raf Castellanos, Tom Johnson, Dialysis Connector and Cap Having an Integral Disinfectant, Baxter International Inc, Baxter Healthcare S. A. April, 2007, US 7,198,611 B2.
- [6] Christopher T. Davey, Michael R. Sansoucy, Matthew N. McCarthy, High Flow Rate Dialysis Catheters and Related Methods, Scimed Life Systems, Inc., July, 2003 US 6,595,966 B2.
- [7] Sobue, Katsuyoshi (Toyko, JP) Sato, Katsuo (Tokyo, JP) Kondo, Ko (Tokyo, JP) Yamaguchi, Akinori (Tokyo, JP) (2012), Peritoneal Dialysis Patient Connection System, 2012 April 17 US Patent 8157761B2.
- [8] Robert W. Childers, Peritoneal Dialysis Machine, Dec.2, 2014, US 8900174 B2.

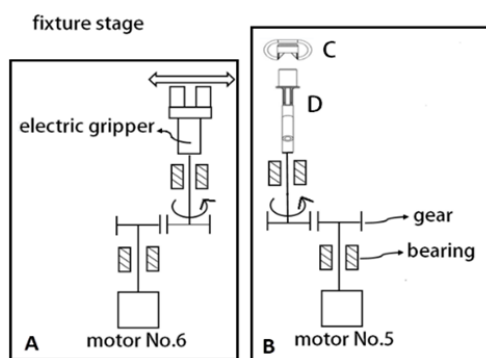

Fig. 5 (A) Holding fixture unit on the platform; (B) schematic for docking and disconnection units; see Fig. 1 for components C and D

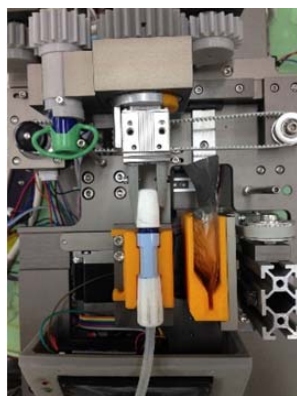

Fig. 6 Top view of connection device. The center part, i.e. Fig. 1 (B), is the fistula connector preinstalled on the patient

V.CONCLUSIONS

This study proposed an auxiliary semiautomatic mechanism for a PD catheter connection, which simplified the original seven manual processes into two processes without any contamination concerns for the patients. During manual implementation of the steps, the patients were not required to remain by the device and could remove the catheter with the space to move freely; this greatly improved the space