

Large Strain Compression-Tension Behavior of AZ31B Rolled Sheet in the Rolling Direction

A. Yazdanmehr, H. Jahed

Abstract—Being made with the lightest commercially available industrial metal, Magnesium (Mg) alloys are of interest for light-weighting. Expanding their application to different material processing methods requires Mg properties at large strains. Several room-temperature processes such as shot and laser peening and hole cold expansion need compressive large strain data. Two methods have been proposed in the literature to obtain the stress-strain curve at high strains: 1) anti-buckling guides and 2) small cubic samples. In this paper, an anti-buckling fixture is used with the help of digital image correlation (DIC) to obtain the compression-tension (C-T) of AZ31B-H24 rolled sheet at large strain values of up to 10.5%. The effect of the anti-buckling fixture on stress-strain curves is evaluated experimentally by comparing the results with those of the compression tests of cubic samples. For testing cubic samples, a new fixture has been designed to increase the accuracy of testing cubic samples with DIC strain measurements. Results show a negligible effect of anti-buckling on stress-strain curves, specifically at high strain values.

Keywords—Large strain, compression-tension, loading-unloading, Mg alloys.

I. INTRODUCTION

THE need to replace steel and aluminum alloys with lighter components has been increasing. In the automotive industries, using the light-weight materials is a key factor in reducing the overall weight of vehicles and increasing fuel efficiency. Since 1990, the drive to reduce fossil fuel consumption due to its environmental impact has generated renewed interest in employing Mg and its alloys in the automotive industry [1]. However, if the Mg alloys are to be modeled for several processes like shot peening, cold expansion and metal forming, the C-T curves become very important.

Buckling is the main challenge of compressive loading in CT. To prevent this phenomenon, different fixtures have been proposed in the literature. The initial fixture was made for monotonic compression test in which several specimens were packed like a laminate of multiple samples together with an external lateral support [2]. Using glue to attach the packed specimens was the next step [3]. Anti-buckling fixtures provide a lateral support, by means of solid plates that apply an initial side-pressure to a specimen by a screw or a spring [4]-[8]. The length supported by these fixtures was less than the whole length of samples to provide enough space for the

compression test to deform the samples without the fixture hitting the grip of the testing machine. The main disadvantage with these kinds of fixtures is the buckling from the unsupported area. Yoshida et al. [9] used a special fixture of coil-springs attached to solid plates. For friction reduction between the anti-buckling fixture and the sample, Teflon sheets covered with Vaseline were used. Kuwabara et al. [10] employed a novel anti-buckling device using comb-type or fork-shaped dies to support the sample. In this case, the whole length of the sample was supported by the fixture. Cao et al. [11] developed a novel device using two angular sliding blocks connected with a pre-loaded spring. The design was capable of moving freely in the loading direction to provide full-length support of the specimen. Two similar blocks on the two sides of the sample were joined by a screw. Dietrich et al. [12] extended the application of the anti-buckling fixture to cyclic tension-compression tests. They achieved this goal by coupling the side-supporting plates with the grips of their testing machine. A similar fixture was recently used in [13]-[15]. To reduce the effect of bi-axiality, [16]-[19] used a servo hydraulic system to apply constant side force to ensure that the effect of lateral stress is negligible compared to the loading stress. Also, some setups have been proposed to measure the friction between an anti-buckling fixture and a specimen to reduce calculation errors in stress-strain curve [14] [12].

Another method of obtaining the compression stress-strain curve at higher strain values, which is using a bulk material, has been standardized [20]. The accuracy of the machining and the favorable aspect ratios have been discussed in [20]. It is mentioned that both ends of the compression samples should be flat and parallel to within 0.0002 (mm/mm). Recently, Kang and Gong [21] used a customized fixture for compression testing of AA6060. The sample dimensions were 6 mm long and 4 mm wide. They put their samples in a fixture with a larger diameter and attached an extensometer to the fixture to read strain values. They inserted the carbon plates in the fixture to provide parallel surfaces. Muhammad et al. [22] used the same fixture to obtain the stress-strain curves of AZ31B and ZEK100 using rectangular sheet samples (6 mm long and 4 mm wide). Ghaffari Tari et al. [23] characterized the monotonic behavior of AZ31B sheets by means of a customized fixture for testing cubic samples.

In this paper, first, C-T stress-strain curves of AZ31B-H24 rolled sheet are obtained in the rolling direction by modifying a fixture proposed by Dietrich and Turski [24], and second, a bulk material (a rectangular sheet sample) is tested to determine the effect of anti-buckling fixture on the stress-strain curve.

A. Yazdanmehr is with the Fatigue and Stress Analysis Laboratory, University of Waterloo, Waterloo, N2L 3G1, Canada (corresponding author, e-mail: amir.yazdanmehr@uwaterloo.ca).

H. Jahed is with the Fatigue and Stress Analysis Laboratory, University of Waterloo, Waterloo, N2L 3G1, Canada (e-mail: hjahedmo@uwaterloo.ca).

II. MATERIAL AND EXPERIMENT

A. Material

The material used in this study is AZ31B-H24 rolled sheet, with a thickness of 4 mm for the anti-buckling tests and 6.3 mm for cubic specimen tests. Table I shows the chemical composition of this alloy [25]. The density and Young's modulus of elasticity are 1770 kg/m³ and 45 GPa, respectively [26].

TABLE I
 CHEMICAL COMPOSITION OF AZ31B ROLLED SHEET

Composition	Al	Zn	Mn	Fe	Ni	Cu	Mg
Weight %	3.1	1.05	0.54	0.0035	0.0007	0.0008	Bal.

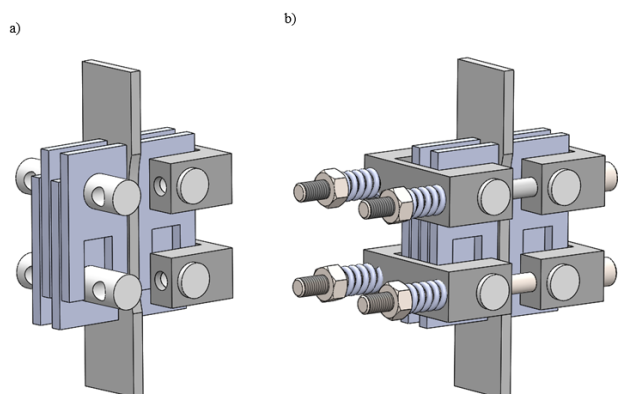

Fig. 1 Anti-buckling fixture used in this study, a) view of supporting plates' assembly b) Full assembly of fixture

B. Experiments

1. Compression Test Using Anti-Buckling Fixture

The anti-buckling fixture is manufactured according to a fixture proposed in the literature [24]. This fixture provides full lateral support of the specimen during the compression test. As shown in Fig. 1, supporting plates have the capability to move as grips of the testing machine move towards each other. The screws connecting the two working parts provide adjustments for testing different sample thicknesses. The U-shape parts support the pins and avoid any rotation during testing. A spring is used to allow the thickness to increase during compressive loading. According to the relevant ASTM standard [20], acceptable results can be observed with rather wide ranges of lateral-support pressures and spring constants. Measuring the Young's modulus of elasticity has been proposed as a good indicator of the fixture qualification [20]. A Teflon sheet is used to minimize friction between the fixture and specimen.

Fig. 2 shows the sample geometry when the anti-buckling fixture is used. The sheet is 4 mm thick, and lengths of 25 mm extended beyond the fixture are clamped in the grips of the testing machine. The remaining 60 mm is fully supported by the fixture.

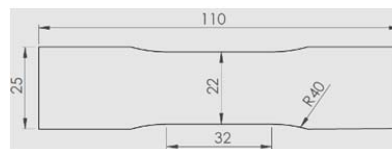

Fig. 2 Specimen geometry for tests using anti-buckling fixture

Tests were done using an MTS machine with a load cell capacity of 50 kN. The strains were measured by an ARAMIS DIC system. Fig. 3 shows the test assembly and the thickness side that is used for strain measurement using DIC.



Fig. 3 Compression test using anti-buckling fixture, using the thickness side for measuring the strain by DIC

2. Compression Test Using Cubic Samples

Compression testing of the cubic samples was done to determine the effect of anti-buckling on the stress-strain curve of the material. The thickness of the sample used to create cubic samples was 6.3 mm, so cubic samples with 6 mm width and 8 mm length were used for compression testing. Fig. 4 shows the schematic assembly of the fixture and experimental set up. To obtain the appropriate sample length, three factors needed to be considered: 1) providing uniform area for strain measurement, and preventing the local effect of boundaries, 2) providing enough space to measure the strain by DIC, and 3) having short enough sample length to prevent buckling during the test. A customized hardened stainless steel fixture has been used in this study. Compression testing of cubic samples is very sensitive to the accuracy of fixture and specimen machining; inaccuracies result in obtaining a Young's module of elasticity that differs significantly from the actual value. Both ends of the cubic sample needed to be parallel to within 0.0002 (mm/mm) [20]. Fixture accuracy was increased by several improvements: 1) the width of the fixture was chosen to be exactly the same as the width of the testing machine grips so as to minimize errors in adjusting the fixture on the testing machine, 2) the fixture was made from one piece of stainless steel to avoid assembling errors from using glue or screws, and 3) an adjustment tool (Fig. 4 (c)) positioned the specimen exactly in the loading center before the test started.

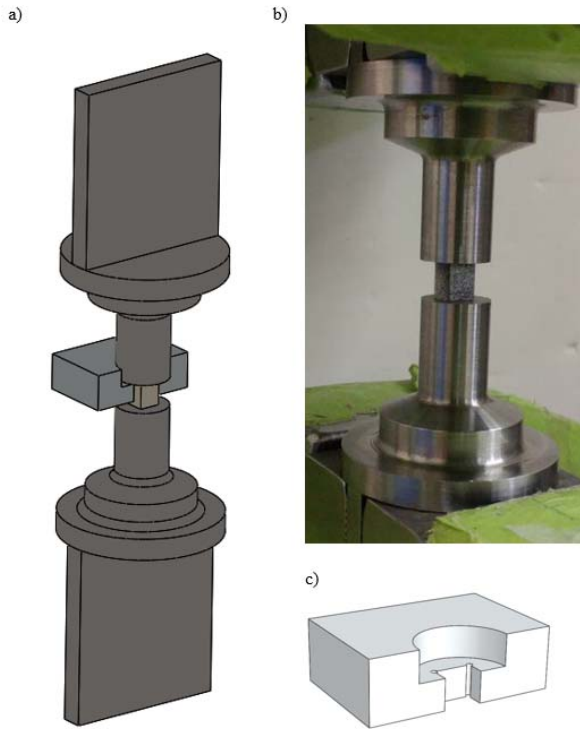

Fig. 4 Fixture for compression test of cubic sample, using the adjustment tool in the beginning of the test to locate the sample. (a) Schematic view (b) Experiment set up (c) adjustment tool

The cylindrical section of the tool was fitted to a similar section of the fixture, and its bottom was tightly fitted to the cubic specimen to minimize error. After applying a small force, e.g. 100 N, the adjustment tool was removed.

III. RESULTS AND DISCUSSION

The C-T test results in the rolling direction are shown in Fig. 5, which also shows a comparison between the curves obtained using the anti-buckling fixture and the cubic specimen, a comparison that has until now been missing from the literature. The results are in a good agreement with each other, confirming that there is no need to use a hydraulic servo-motor to apply constant pressure so as to make sure that the effect of bi-axially is negligible. Using the above-mentioned method for the anti-buckling fixture leads to equally acceptable results.

The results of the Young's modulus and yield stress in the rolling direction for compression tests are mentioned in Table II. The compression tests using the anti-buckling fixture predict the Young's modulus of elasticity very accurately in compression. The proposed fixture for testing cubic samples can predict also the Young's modulus acceptably.

TABLE II
 YOUNG'S MODULUS AND YIELD STRESS OF AZ31B-H24 IN ROLLING DIRECTION IN COMPRESSION TEST

Compression test	Young's modulus (GPa)	Yield stress (MPa)
Using anti-buckling (4 mm sheet)	45.02	171.81
Cubic specimen test (6.3 mm sheet)	43.83	159.61
Cubic specimen test (4 mm sheet) [26]	44.67	161.24

Table II also shows no meaningful difference between the plastic behavior of rolled sheets with the thicknesses of 6.3 mm and 4 mm. Behraves obtained the compression behavior of 4 mm AZ31B rolled sheet by attaching two sheets together using glue [26]. Fig. 6 compares the compression stress-strain curves of AZ31b-H24 rolled sheet with the thicknesses of 6.3 and 4 mm.

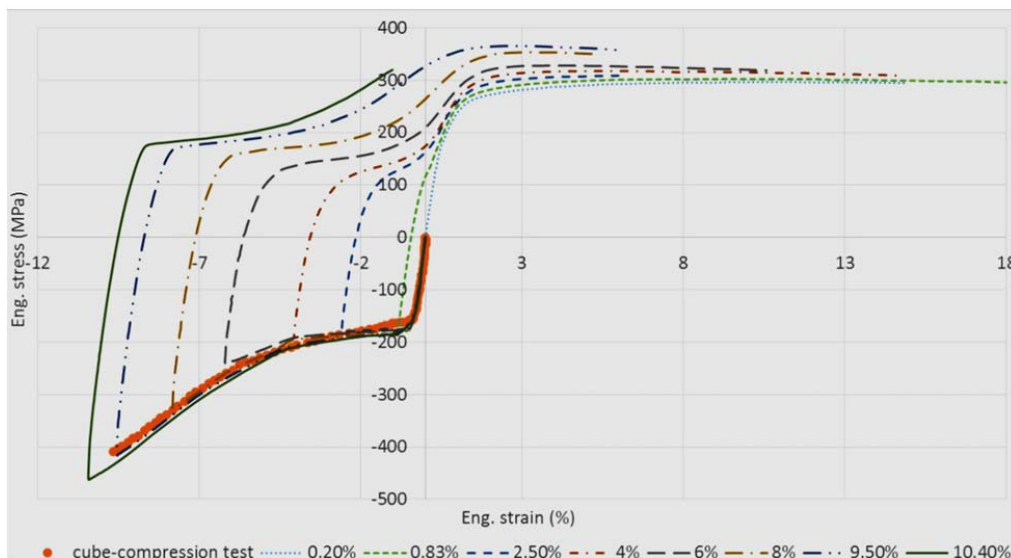

Fig. 5 CT results of AZ31B rolled sheet in rolling direction using the anti-buckling fixture and comparison with cubic sample

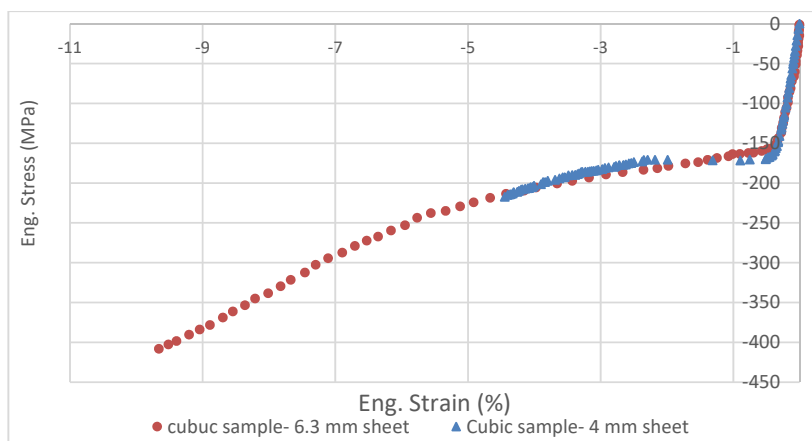

Fig. 6 Compression test of cubic samples machines from 6.3 mm sheet (this study), and 4 mm sheet [26]

Fig. 6 confirms that the plastic behavior of the 4 mm and 6.3 mm rolled sheets can be assumed the same.

IV. CONCLUSION

This study proposed a modified version of an anti-buckling fixture to obtain the C-T curves of AZ31B-H24 sheet at different large strain values. The negligible effects of using an anti-buckling fixture were experimentally confirmed by comparing the results with the results of compression tests using cubic samples and corresponding fixture. A new fixture and adjustment tool were introduced that can increase the accuracy of compression tests using cubic samples. It was shown that the Young's modulus of elasticity obtained from cubic samples and DIC measurements were in complete agreements with expected values.

ACKNOWLEDGMENT

This work is financially supported by the Natural Sciences and Engineering Research Council of Canada, the Automotive Partnership Canada (APC) program under APCPJ 459269-13 grant with contributions from Multimatic Technical Centre, Ford Motor Company, and Centerline Windsor. The authors would also like to thank Seyed Behzad Behravesh and Ali Roostaei of the University of Waterloo for assistance with designing and performing the tests.

REFERENCES

- [1] C. Blawert, N. Hort, and K. U. Kainer, "Automotive Applications of Magnesium and Its Alloys," *Magnesium*, vol. 57, no. 4, pp. 397–408, 2006.
- [2] C. S. Aitchison and L. B. Tuckeuian, "The 'Pack' method for compressive tests of thin specimens of materials used in thin-wall structures," 1939.
- [3] C. S. Aitchison, "Extension of Pack Method for Compressive Tests," *Natl. Advis. Comm. Aeronaut.*, no. 789, 1940.
- [4] J. A. Miller, "A fixture for compressive tests of thin sheet metal between lubricated steel guides," *Natl. Advis. Comm. Aeronaut.*, no. 1022, 1946.
- [5] J. N. Kotanchik, W. Woods, and R. A. Weinberger, "Investigation of methods of supporting singlethickness specimens in a fixture for determination of compressive stress-strain curves," *Natl. Advis. Comm. Aeronaut.*, no. L5E15, 1945.
- [6] H. LaTour and D. S. Wolford, "Single-strip compression test for sheet materials," in *ASTM*, 1945, pp. 671–688.
- [7] R. L. Templin, "Discussion of single-strip compression test for sheet

- materials," in *ASTM*, 1945, pp. 690–693.
- [8] P. E. Sandorff and R. K. Dillon, "Compressive stress-strain properties of some aircraft materials," in *ASTM*, 1946, pp. 1039–1052.
- [9] F. Yoshida, T. Uemori, and K. Fujiwara, "Elastic – plastic behavior of steel sheets under in-plane cyclic tension – compression at large strain," *Int. J. Plast.*, vol. 18, pp. 633–659, 2002.
- [10] T. Kuwabara, Y. Morita, Y. Miyashita, and S. Takahashi, "Elastic-plastic behavior of sheet metal subjected to in-plane reverse loading. Proceedings of the Fifth International Symposium on Plasticity and Its Curren," in *Fifth International Symposium on Plasticity and Its Curren*, 1995, pp. 841–844.
- [11] J. Cao, W. Lee, H. S. Cheng, M. Seniw, H. P. Wang, and K. Chung, "Experimental and numerical investigation of combined isotropic-kinematic hardening behavior of sheet metals," *Int. J. Plast.*, vol. 25, no. 5, pp. 942–972, 2009.
- [12] L. Dietrich, G. Socha, and Z. L. Kowalewski, "Anti-buckling fixture for large deformation tension-compression cyclic loading of thin metal sheets," *An Int. J. Exp. Mech.*, vol. 50, no. 2, pp. 174–183, 2014.
- [13] Z. L. Kowalewski, L. Dietrich, and G. Socha, "Experimental investigation of thin metal sheets under tension-compression cyclic loading 1 Introduction 2 Experimental details," *8th Australas. Congr. Appl. Mech. ACAM 8*, no. November, 2014.
- [14] T. Libura, Z. L. Kowalewski, L. Dietrich, and G. Socha, "Anti-buckling System for Flat Specimens Investigations under Cyclic Tension-compression," *Mater. Today Proc.*, vol. 3, no. 4, pp. 1045–1050, 2016.
- [15] Z. L. Kowalewski, L. Dietrich, and G. Socha, "Experimental investigation of thin metal sheets under tension-compression cyclic loading 1 Introduction 2 Experimental details," *8th Australas. Congr. Appl. Mech. ACAM 8*, no. November, pp. 757–762, 2014.
- [16] T. Kuwabara, Y. Kumano, J. Ziegelheim, and I. Kurosaki, "Tension-compression asymmetry of phosphor bronze for electronic parts and its effect on bending behavior," *Int. J. Plast.*, vol. 25, no. 9, pp. 1759–1776, 2009.
- [17] R. K. Boger, R. H. Wagoner, F. Barlat, M. G. Lee, and K. Chung, "Continuous, large strain, tension/compression testing of sheet material," *Int. J. Plast.*, vol. 21, no. 12, pp. 2319–2343, 2005.
- [18] M. Omar, T. Kuwabara, and D. Steglich, "Material modeling of AZ31 Mg sheet considering variation of r -values and asymmetry of the yield locus," *Mater. Sci. Eng. A*, vol. 549, pp. 82–92, 2012.
- [19] M. G. Lee, J. H. Kim, D. Kim, O. S. Seo, N. T. Nguyen, and H. Y. Kim, "Anisotropic Hardening of Sheet Metals at Elevated Temperature: Tension-Compressions Test Development and Validation," *Exp. Mech.*, vol. 53, no. 6, pp. 1039–1055, 2013.
- [20] ASTM Standard E9-09, "Standard Test Methods of Compression Testing of Metallic Materials at Room Temperature," *Annu. B. ASTM Stand.*, vol. 3.01, no. 1, pp. 92–100, 2012.
- [21] J. Kang and K. Gong, "Determination of Fracture Behavior of AA6060 Aluminum Alloy Extrusion Using Digital Image Correlation," *Eval. Exist. New Sens. Technol. Fatigue, Fract. Mech. Test.*, vol. STP 1584, pp. 13–31, 2015.
- [22] W. Muhammad, M. Mohammadi, J. Kang, R. K. Mishra, and K. Inal, "An elasto-plastic constitutive model for evolving asymmetric/anisotropic hardening behavior of AZ31B and ZEK100

- magnesium alloy sheets considering monotonic and reverse loading paths," *Int. J. Plast.*, vol. 70, pp. 30–59, 2015.
- [23] D. Ghaffari Tari, M. J. Worswick, U. Ali, and M. A. Gharghouri, "Mechanical response of AZ31B magnesium alloy: Experimental characterization and material modeling considering proportional loading at room temperature," *Int. J. Plast.*, vol. 55, pp. 247–267, 2014.
- [24] L. Dietrich and K. Turski, "A new method of thin sheets testing under compression (in Polish)," *Eng. Trans.*, vol. 26, no. 1, pp. 91–99, 1978.
- [25] J. Al Bin Mousa, "Multiaxial Fatigue Characterization and Modeling of AZ31B Magnesium Extrusion," 2011.
- [26] S. B. Behraves, "Fatigue Characterization and Cyclic Plasticity Modeling of Magnesium Spot-Welds," University of Waterloo, 2013.