

Low-Cost Robotic-Assisted Laparoscope

Ege Can Onal, Enver Ersen, Meltem Elitas

Abstract—Laparoscopy is a surgical operation, well known as keyhole surgery. The operation is performed through small holes, hence, scars of a patient become much smaller, patients can recover in a short time and the hospital stay becomes shorter in comparison to an open surgery. Several tools are used at laparoscopic operations; among them, the laparoscope has a crucial role. It provides the vision during the operation, which will be the main focus in here. Since the operation area is very small, motion of the surgical tools might be limited in laparoscopic operations compared to traditional surgeries. To overcome this limitation, most of the laparoscopic tools have become more precise, dexterous, multi-functional or automated. Here, we present a robotic-assisted laparoscope that is controlled with pedals directly by a surgeon. Thus, the movement of the laparoscope might be controlled better, so there will not be a need to calibrate the camera during the operation. The need for an assistant that controls the movement of the laparoscope will be eliminated. The duration of the laparoscopic operation might be shorter since the surgeon will directly operate the camera.

Keywords—Laparoscope, laparoscopy, low-cost, minimally invasive surgery, robotic-assisted surgery.

I. INTRODUCTION

ROBOT-ASSISTED operations require high dexterity; Robots can provide high precision, accuracy and flexibility to surgeons [1], [2]. In literature, the first surgical robot assisted orthopedic operation was performed using Arthrobot in 1983 [3]. In 1985, the first true non-laparoscopic robot-assisted surgery was achieved using PUMA 560 in the neurosurgical operations [4]. In 1992, the ROBODOC was built in order to assist doctors during the total hip replacement surgeries. Moreover, the ROBODOC is the first robot that received approval from the Food and Drug Administration (FDA) [5]. In 2000, the da Vinci Surgery system was invented and it became the first FDA-approved robot that has been performing laparoscopic surgeries [6]. Today, robot-assisted laparoscopic operations are involved in a variety of operations such as neurology, urology, gynecology and cardiothoracy [7]-[10].

To achieve robot-assisted laparoscopic operations, several laparoscopic instruments have been developed such as cannulas, trocars, trocar incision closure devices, electrosurgical cables, laparoscopic bipolar scissors, graspers, forceps, hooks, probes, knot, pushers, needles, needle holders, retractors. These instruments can stitch, sew, cut, grasp in the presences of a laparoscope (scope). Conventional laparoscope is called rigid scope. As its name, it has rigid tubular shape. It

Enver Ersen and Meltem Elitas are with the Faculty of Engineering and Natural Sciences, Sabanci University, 34956, Istanbul, Turkey (e-mail: enverersen@sabanciuniv.edu, melitas@sabanciuniv.edu).

Ege Can Onal is with the Faculty of Engineering and Natural Sciences, Sabanci University, 34956, Istanbul, Turkey (corresponding author, e-mail: onalege@sabanciuniv.edu).

consists of series of lenses or flexible employing optic fibers to convey the illuminating light, and the image into the eyepiece [11]. Because of its rigidity, the camera at the tip of a device is stationary, which might lead to some limitations. For example, the surgeon has limited view of the operation area (abdomen of a patient) at the right angle. There is an assistant who just holds and moves the laparoscope during the surgery. To overcome these limitations and provide a precise laparoscope movement that is directly controlled by the surgeon, we designed a robotic-assisted laparoscope. Thanks to its lightness, mobility, user-friendliness and affordability, it might assist in several laparoscopic operations.

II. MATERIALS AND METHODS

A. Mechanical Design and Kinematics

The robotic-assisted laparoscope is designed using SolidWorks (2015). The robotic-assist laparoscope consists of three linkages connected with three revolute joints and one ground joint as illustrated in Fig. 1.

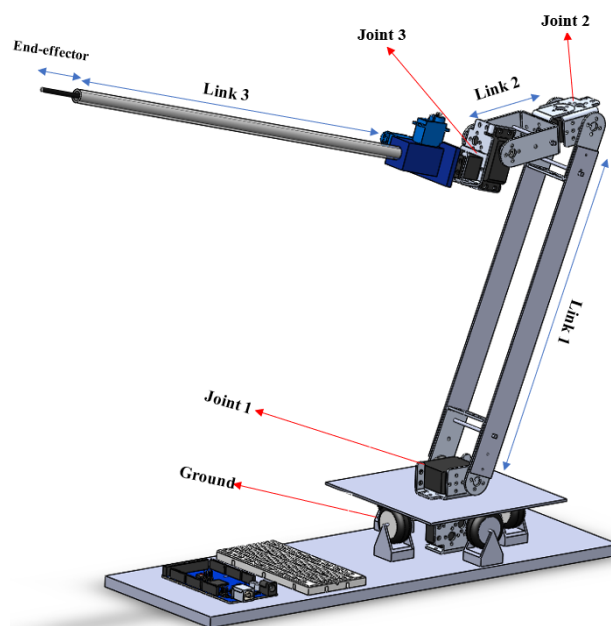

Fig. 1 Robot-assisted laparoscope and its links and joints

Fig. 2 illustrates the kinematic diagram of the robotic-assisted laparoscope, which is used to develop the forward kinematic equations. Table I represents the Denavit-Hartenberg conventions, where l illustrates the length of links, θ represents the joint angles, α shows the twist, d presents the offset, i indicates the number of joints and links, $i = 1, 2, 3$.

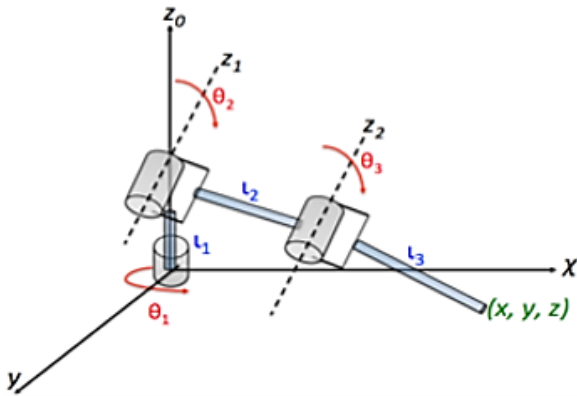

Fig. 2 Robot-assisted laparoscope and its kinematic diagram

Using the parameters from Table I, the transformation matrix, T , will be obtained (1), where c : cosine, s : sinus, $\theta_i = 1, 2, 3$.

TABLE I
JOINT PARAMETERS

Link i	L_i	A_i	D_i	θ_i
1	l_1	-90	0	θ_1
2	l_2	0	0	θ_2
3	l_3	0	0	θ_3

$$T = \begin{bmatrix} (c_1c_2c_3 - c_1s_2s_3) & -(c_1c_2s_3 + c_1s_2c_3) & -s_1 & (l_1c_1 + l_2c_1c_2 + l_3c_1(c_2c_3 - s_2s_3)) \\ (s_1c_2c_3 - s_1s_2s_3) & -(s_1c_2c_3 + s_1s_2c_3) & c_1 & (l_1s_1 + l_2s_1c_2 + l_3s_1(c_2c_3 - s_2s_3)) \\ -(s_2c_3 + c_2s_3) & (s_2s_3 - c_2c_3) & 0 & -(l_2s_2 + l_3(s_2c_3 - c_2s_3)) \\ 0 & 0 & 0 & 1 \end{bmatrix} \quad (1)$$

Using the transformation matrix, the forward kinetics will be as follows.

$$x = l_1c_1 + l_2c_1c_2 + l_3c_1(c_2c_3 - s_2s_3) \quad (2)$$

$$y = l_1s_1 + l_2s_1c_2 + l_3s_1(c_2c_3 - s_2s_3) \quad (3)$$

$$z = -(l_2s_2 + l_3(s_2c_3 + c_2s_3)) \quad (4)$$

B. Manufacturing the Robot-Assisted Laparoscope

Fig. 3 shows the image of the robotic-assisted laparoscope. It mainly consists of a phantom, which mimics the human abdominal, a monitor to see the incision, a power supply, a control pedal, and a robotic-assisted laparoscope.

As illustrated in Fig. 3, the robotic-assisted laparoscope is mounted on a base. The base is manufactured from a sheet metal and four small wheels to carry the robot and mount the electronic circuit.

Fig. 4 presents the phantom, robotic-assisted laparoscope in details, whereas Fig. 5 shows the camera movements.

Firstly, the second and third revolute joints were motorized by Tower Pro MG-996 servomotors which have the capability of providing 11 kg.cm torque. The first revolute joint has Tower Pro MG-958 servomotor that provides 20 kg. cm torque. Two Tower Pro SG-90 servomotors were mounted on the blue 3D printed part and they have 1.8-kg.cm torque.

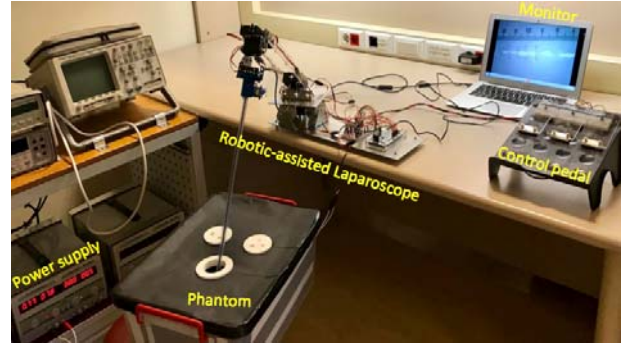

Fig. 3 Setup for the robot-assisted laparoscope



Fig. 4 Artificial tissue inside the phantom



Fig. 5 Camera angles

The links were fabricated using light and low-cost materials. The first link was manufactured using a 30-cm Plexiglas. The third link is composed of a 10 mm-radius plastic tube that carries the camera cable and wires with a mounted camera. The third link can fit into the trocar.

TABLE II
MAIN COMPONENTS AND THEIR FUNCTIONS

Component	Function
MG-996 Servomotor	Serves as an actuator for joint 1,3 and 4.
MG-958 Servomotor	Since the largest load is on the joint 2, the motor supplies larger torque was used.
G-90 Servomotor	Two motors were used to power the joint 5.
Arduino MEGA	Processor unit of the device.
Phantom	Experiment setup that mimics human body.
Camera	Camera is used to get a vision from laparoscope.
LED	LEDs are show the motor selection.
Pedals	Pedals are used for selection of motors and to move the motors.
Second Link	Link was made from Plexiglas material for lightweight.
Fourth Link	Tubular shaped link that carries cables of camera and motors.
Power Supply	Supplies power to the system.
Artificial Tissue	Mimics human skin during the experiment.

Four wires controlled the end-effector, the camera in our

system. These wires were attached to two servomotors and to control fine movement of the camera. The camera has 5.5 mm diameter with 6-LED. It is 720p (HD), IP67 waterproof.

Three pedals control the motion of the robotic-assisted laparoscope. One pedal is dedicated to select the actuators, while two of them control their rotations. Control of the system is achieved using the Arduino MEGA microcontroller board based on the ATmega26. The controller has 54 digital input/output and 16 analog inputs [6].

The manufacturing cost of the system was 100\$. The total weight of the system is 1.8 kg.

III. RESULTS

Experiments were performed by placing the laparoscope inside the phantom through the trocar openings as illustrated in Fig. 3 and explained in Table III. Next, the movement of the camera is monitored measuring the encoder values and taking the images of the artificial skin as shown in Figs. 4-6.

For the experiment, initially, the camera moved 2 cm from 8 to 10 on the artificial tissue. The camera angle was 90°, when it moved to 10, its angle set to 45°. This movement was performed in 400 microseconds. Afterwards, the camera angle set to 0° and the camera was moved 5 cm and positioned at 14 in 450 microseconds. Finally, the camera angle was set to 180° and the camera was placed to 4 via moving 12 cm in 1856 microseconds. Table III and Fig. 5 show the camera angles.





IV. DISCUSSION

Our robotic-assisted laparoscope provides low-cost, light and user-friendly camera control for laparoscopic operations. Our preliminary results showed that pedal controlled robotic-assisted laparoscope follows the pedal commands in a short time with relatively good image resolution (see Fig. 5).

The manufacturing cost of the robot-assisted laparoscope that we presented here is very low, therefore many surgical rooms can afford it, especially in the developing countries. Our system is very light in comparison with other robotic-assisted surgical tools, therefore it can be easily modified to

hang on the surgical table or directly used as we illustrated in our experiments. Moreover, the usage of the robot is very easy and practical for the surgeon since they have already trained using several pedals in the operating rooms such as moving the surgical table, operating the aspiration. Therefore, they will not need to have special training. Another advantage that our robotic-assisted laparoscope presents is the necessity of a nurse to hold and control the camera will be eliminated. The surgeon can rapidly and easily direct the camera to the coordinates that he/she planned to visualize. Last but not least, the robotic-assisted laparoscope will be very useful for surgical training. Nowadays, most of the surgical practices have been performed using phantom devices and simulators.

TABLE III
 MAIN COMPONENTS AND THEIR FUNCTIONS

STEP	Work	Image
I.	Power supply cables were plugged, and voltage was set.	
II.	Robot moved its home position.	
III.	First pedal is used to select motors; second and third pedals were used to turn the motors.	
IV.	To place the laparoscope inside the phantom, the pedal_1 was pressed and the robot moved, the next pedal_2 was pressed and the end-effector was moved down.	
V.	The images inside the phantom were captured and it was observed on the monitor, Fig. 6.	

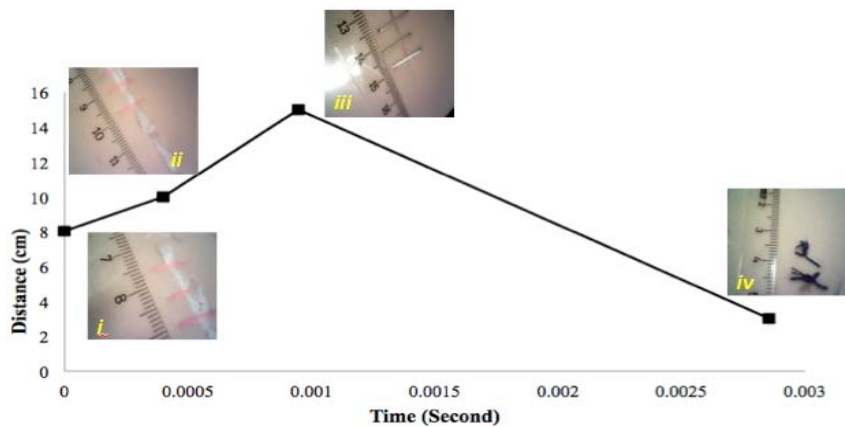

Fig. 6 Movement of the robotic-assisted laparoscope

However, our robotic-assisted laparoscope is just a prototype and it needs several improvements. For example,

when the camera is moved in high speeds, it might vibrate and images might become blurry. Therefore, instead of using

Plexiglas more rigid and safe material should be used while optimizing the control to obtain robustness. Second, biosafety is not considered in the presented experiment. When the control algorithm is advanced, the limits need to be determined in order to prevent the damage on the surrounding tissue. The properties of the manufacturing material should be biocompatible to be able to operate it in real surgery.

ACKNOWLEDGMENT

Authors thank for support of Faculty of Engineering and Sciences at Sabanci University and surgeon Assoc. Dr. Tugrul Tansug for the valuable scientific discussion.

REFERENCES

- [1] A. G. Gallagher, N. McClure, J. McGuigan, K. Ritchie, N. P. Sheehy, "An Ergonomic Analysis of the Fulcrum Effect in the Acquisition of Endoscopic Skills", *Endoscopy*, vol.1, no. 7, 2007, pp. 617–620.
- [2] J. C. Rosser, L. E. Rosser, R. S. Savalgi, "Skill acquisition and assessment for laparoscopic surgery", *Arch. Surg.*, vol. 132, 1997, pp. 200–204.
- [3] D. R. Yates, C. Vaessen, M. Roupret, "From Leonardo to da Vinci: The history of robot-assisted surgery in urology", *BJU Int.*, vol. 108, no. 11, 2011, pp. 1708-1713.
- [4] P. R. Rizun, P. B. McBeth, D. F. Louw, G. R. Sutherland, "Robot-Assisted Neurosurgery", *Seminars in Laparoscopic Surgery*, vol. 11, no. 2, June 2004, pp. 99-106.
- [5] J. Pransky, "ROBODOC - surgical robot success story", *Industrial Robot: An International Journal*, vol. 24, no 3, 1997, pp. 231-233.
- [6] F. Pugin, P. Bucher, P. Morel, *Journal of visceral surgery*, 2011.
- [7] Sallinen V., Mentula P., "Laparoscopic appendectomy", *Duodecim*, vol. 133, no.7, 2017, pp. 660-666.
- [8] R. Mirhashemi, B. L. Harlow, E. S. Ginsburg, L. B. Signorello, R. Berkowitz, S. Feldman, "Predicting risk of complications with gynecologic laparoscopic surgery". *Obstet Gynecol*, vol. 92, no.3, 1998, pp. 327–31.
- [9] R. M. Jimenez-Rodríguez, J. J. Segura-Sampedro, "Laparoscopic approach in gastrointestinal emergencies". *World Journal of Gastroenterology*, vol.22, no.9, 2016, pp 2701.
- [10] D. Bhandarkar, G. Mittal, R. Shah, A. Katara, T.E. Udawadia E. "Single-incision laparoscopic cholecystectomy: How I do it?", *Journal of Minimal Access Surgery*, vol.7, no.1, 2011, pp. 17–23.
- [11] F. Corcione, C. Esposito, "Advantages and limits of robot-assisted laparoscopic surgery: preliminary experience", *Surgical Endoscopy and Other Interventional Techniques*, vol. 19, no. 1, 2004, pp. 117-119.

Ege Can Onal was born in Izmir, Turkey, in 1994. He will receive his B.E. degree in Mechatronics Engineering at Sabancı University, Istanbul, Turkey, in 2019. His current research interests include biomechanics, surgical robotics, industrial robotics, soft robotics and industrial control. He will complete his internship at Hexagon Ortho, Istanbul, Turkey. He is currently working on Laparoscopic Robots on his graduation project.

Enver Ersen was born in Bursa, Turkey, in 1995. He is currently studying at Sabanci University as an undergraduate student in Mechatronics Engineering Program. His main areas of research interest are biomedical robots, biomechanics, soft robotics and electrical vehicles. He performed his internship at FIAT. He is currently working on graduation project, which is about design and development of an induction motor design.

Meltem Elitas was born in Tekirdag, Turkey, in 1983. She received her bachelor degree at Electrical Engineering in Yildiz Technical University. She obtained her master degree at Mechatronics Engineering Program in Sabanci University. She performed her doctoral studies at Bioengineering and Biotechnologies at EPFL. Currently she is a faculty member in Mechatronics Program at Sabanci University. Her research group Biomechanics focus on development of microfabricated tools to understand cellular individuality and contributing laparoscopic surgery.