

Optimal Control for Coordinated Control of SVEc and PSS Damping Controllers

K. Himaja, T. S. Surendra, S. Tara Kalyani

Abstract—In this article, Optimal Control for Coordinated Control (COC) of Series Vectorial Compensator (SVEc) and Power System Stabilizer (PSS) in order to damp Low Frequency Oscillations (LFO) is proposed. SVEc is a series Flexible Alternating Current Transmission System (FACTS) device. The Optimal Control strategy based on state feedback control for coordination of PSS and SVEc controllers under different loading conditions has not been developed. So, the Optimal State Feedback Controller (OSFC) for incorporating of PSS and SVEc controllers in COC manner has been developed in this paper. The performance of the proposed controller is checked through eigenvalue analysis and nonlinear time domain simulation results. The proposed Optimal Controller design for the COC of SVEc and PSS results will be analyzed without controller. The comparative results show that Optimal Controller for COC of SVEc and PSSs improve greatly the system damping LFO than without controller.

Keywords—Coordinated control, damping controller, optimal state feedback controller, power system stabilizer, series vectorial compensator.

I. INTRODUCTION

THE Electrical Power Systems (EPS) are forced to operate closer to their static and dynamic stability limits and damping of Low Frequency Oscillations (0.2-2.5 Hz) is becoming a challenging problem to the researcher [1]. In EPS two modes of oscillations are present local mode and inter area mode. Local mode oscillations frequency range from 0.8 to 2.0 Hz and inter area mode oscillations frequency range from 0.1 to 0.7 Hz [1].

Usually, PSS is a supplementary signal to the exciter of synchronous generator to mitigate LFO and intermittently the PSS do not mitigate LFO notably in case of over-loading conditions [1]. Recently, FACTS controllers have been growing to improve steady-state and dynamic performance. Various types of FACTS controllers TCSC, STATCOM, SSSC and UPFC are based on thyristor or VSC based converters. However, more recently, the authors have been discussing the new controllers based on PWM ac-ac vectorial converters [2]-[5], demonstrating that the control and its performance are similar to VSC converters. SVEc is a series FACTS device offers an approach of controllable series compensation of transmission line reactance and provides

additional damping signal to system critical modes. In a simple system the degree of series compensation automatically adjusted through duty cycle control is presented in [2]. In [3], the authors discuss the comparison of SVEc with TCSC in a small radial power system. To adjust the reactance of a line, with DC and AC controllers using SSSC is presented in [4]. The author of [5] carried out a study of dynamic modelling of SVEc and also stability analysis of SVEc with SSSC and TCSC. The disadvantages of TCSC under open circuit conditions can be defeated with ac controllers [5]. On the other hand a synchronous type PWM is required in SSSC; this leads to many complexities in control infrastructure.

Uncoordinated design of the PSSs and the FACTS damping controller might cause dynamic interactions present between them. But, to counteract aforesaid probable interactions many authors [6]-[13] study the impact of FACTS controller in addition to PSS, some of these methods are based on mathematical programming, eigenvalue approach, fuzzy modelling and artificial neural network. In electric networks, because of system dimensions the COC design of PSS and FACTS damping controllers also rather complex [14]-[16]. The COC design of PSS and SVEc for multimachine network to damp LFO under different loading conditions using mathematical dynamic index is presented in [17].

The OSFC method has been widely used in EPS because of its simplicity and robustness [18]. The main aim of OSFC is to minimize the error in the state of input reference model and state of controlled plant by adjusting feedback gains. In order to boost the damping of LFO modes, the OSFC for COC of SVEc and PSS has been proposed under different loading conditions in multi machine networks.

The main contribution of this work can be organized as:

- An OSFC for COC of SVEc and PSS to damp LFO is presented.
- The gain and time constants of the phase lead/lag stabilizers and Optimal Control weighting matrices are calculated by trial and error.
- The proposed control is simulated on a WSCC-3 machine, 9-bus system.
- All the simulations are carried out in MATLAB.

II. POWER SYSTEM MODEL

The linear model of EPS is as follows [19]

$$\dot{X} = Ax + Bu \quad (1)$$

$$0 = g(x, y) \quad (2)$$

K.Himaja is with the Electrical Engineering Department, Department of Technical Education, Government of AP, India (phone: 91-996676131, e-Mail:himajak2000@yahoo.co.in)

T. S.Surendra is with the visionary lighting and energy systems, Hyd, India (e-mail: surendra.ts@gmail.com).

S. Tara Kalyani is with the Electrical Engineering Department, JNTUH, Telangana, India.

where $x \in R^n$ a state vector associated with each machine; $y \in R^m$ is the output vector, "u" is a set of input vector consider for each machine, and $g(\cdot)$ is the set of algebraic and network equations [5]. Equation (1) is the dimension of 7m and (2) is the dimension of 2(m+n) although, EPS is non-linear and linearized at a certain operating point. It can be defined in state-space as [19].

$$\begin{bmatrix} \Delta \dot{X} \\ 0 \\ 0 \end{bmatrix} = \begin{bmatrix} A' & B'_1 & B'_2 \\ C'_1 & D'_{11} & D'_{12} \\ C'_2 & D'_{21} & D'_{22} \end{bmatrix} \begin{bmatrix} \Delta X \\ \Delta Y_C \\ \Delta Y_B \end{bmatrix} + \begin{bmatrix} E_1 \\ 0 \\ 0 \end{bmatrix} \Delta u \quad (3)$$

D'_{22} is the load-flow jacobian J_{LF} and J'_{AE} is the network algebraic jacobian. The system matrix A_{sys} from (3) is obtained as

$$\Delta \dot{X} = A_{sys} \Delta X + E \cdot \Delta U \quad (4)$$

where

$$[A_{sys}]_{7m \times 7m} = [A'] - [B'_1, B'_2][J'_{AE}]^{-1} \begin{bmatrix} C'_1 \\ C'_2 \end{bmatrix} \quad (5)$$

When damping controllers are placed to the system, the extra state variable corresponding to these controllers will be added to the system matrix.

III. SERIES VECTORIAL COMPENSATOR

The SVEc, as series FACTS device is represented for damping of LFO. The SVEc exploits the variable reactance compensation in power networks. The basic configuration of SVEc device inserted in series with a transmission line is represented in Fig. 1. SVEc mainly consists of (i) Primarily based identical switches $S_{1R}, S_{1Y}, S_{1Z}, S_{2R}, S_{2Y}$ and S_{2Z} and (ii) the compensation capacitors $C_R, C_Y,$ and C_Z . The control and performance of SVEc and switching operation is presented in [20], [21]. The operation of this device based on the concept of series compensation of reactance in transmission lines. The appropriate variation of the duty cycle (D_s) of this device can maintain specified amount of active power flow in a series compensated line.

Fig. 2 shows the SVEc single line diagram of Fig. 1 and the proposed SVEc is placed between bus 1 and 2 as displayed in Fig. 2. X_{12} and X_{SVEc} are the line and injected SVEc reactances of the simple line. In the secondary side, there is the SVEc converter and a bank of capacitors with reactance X_C . The equivalent reactance in the network 1 and 2 from Fig. 2 can be calculated as [5]

$$X_{Total} = X_{12} + X_{SVEc} \quad (6)$$

The relation between the reactance of the network and duty cycle can be defined as [5]

$$X_{SVEc} = -K^2(1 - D_s)^2 X_C \quad (7)$$

where X_C the capacitor reactance, transformer turns ratio is

K and D_s is the term duty ratio is defined as the ratio of the on-state to the total switching period. Equation (7) shows that the net reactance X_{SVEc} depends on duty cycle D_s .

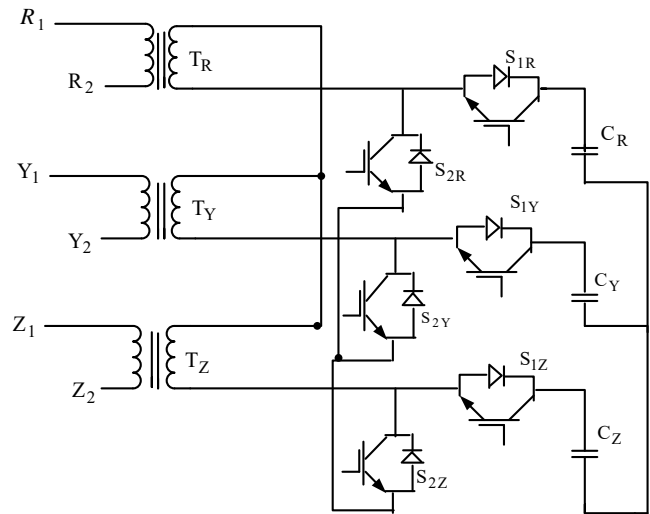

Fig. 1 PWM SVEc inserted in a transmission line

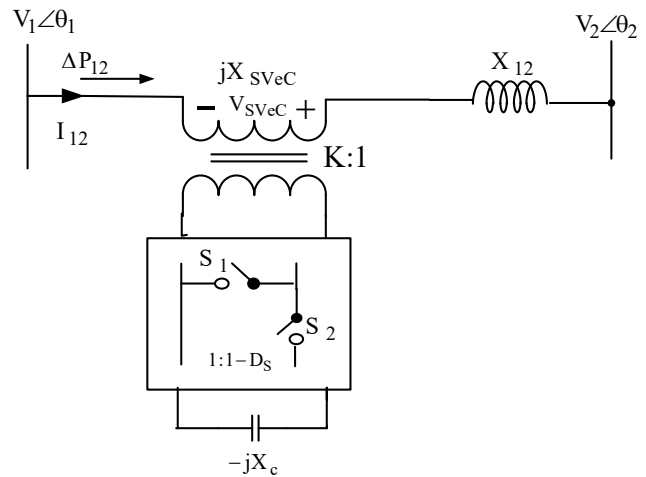

Fig. 2 Single line diagram of EPS with SVEc

The limit imposed by SVEc is D_s . Thus $X_{SVEcmin} \leq X_{SVEc} \leq X_{SVEcmax}$. The net susceptance of the transmission line is calculated as

$$B = B_{12} - B_{eq} = \frac{1}{X_{12}} - \frac{1}{X_{12} + X_{SVEc}} \quad (8)$$

The power flows in the network 1 and 2 can be described as

$$P_{12} = V_1 V_2 (B_{12} + B) \sin(\theta_1 - \theta_2) \quad (9)$$

$$P_{21} = -P_{12} \quad (10)$$

$$Q_{12} = V_1^2 (B_{12} + B) - V_1 V_2 (B_{12} + B) \cos(\theta_1 - \theta_2) \quad (11)$$

$$Q_{21} = V_2^2 (B_{12} + B) - V_1 V_2 (B_{12} + B) \cos(\theta_1 - \theta_2) \quad (12)$$

IV. PSS AND SVEc DAMPING CONTROLLER

A. PSS

The PSS add the speed deviation with damping force [1]. It contains a transfer function having a gain block; wash out block and lead-lag compensator. Phase compensator province is to control the phase lag between exciter and generator electrical torque [1]. Gain block serves the level of damping to the input. The wash-out block is omitted in this paper. Fig. 3 shows the commonly used general block diagram of PSS damping controller. The transfer function of PSS structure is given by

$$\frac{V_S}{\Delta\omega_m} = K_{PSS} \left(\frac{sT_w}{1+sT_w} \right) \left(\frac{1+sT_1}{1+sT_2} \right) \quad (13)$$

where T_2 is the lead is time constant and T_1 is the lag time constant. The input signal to the PSS is $\Delta\omega_m$ i.e. deviation in speed from synchronous speed and the output of PSS is the supplementary signal (V_S). V_S is added to V_{Sref} and V_t to the exciter, so as to damp the LFO in a network. Therefore the system matrix A_{PSS} for a study network is $[[A_{PSS}]_{(7m+1) \times (7m+1)}]$. So, test system eigen-values will be increased by one [22].

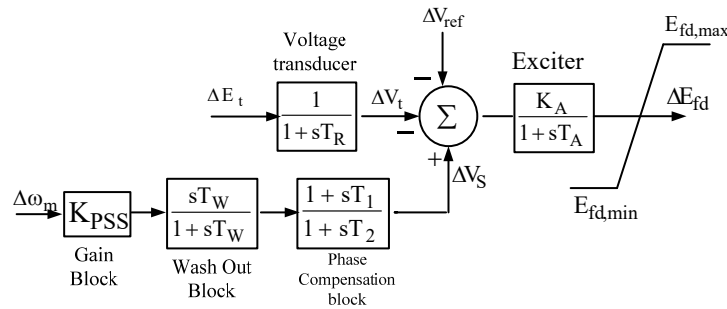

Fig. 3 Simplified block diagram for proposed PSS

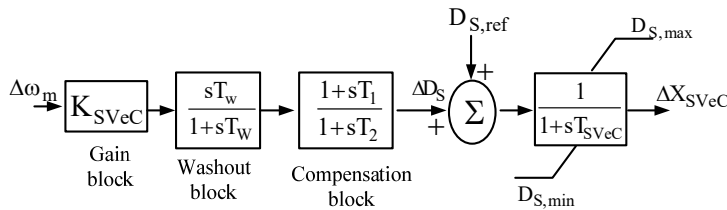

Fig. 4 Block diagram of SVEc damping controller

A. SVEc Damping Controller

The block diagram of SVEc based stabilizer is shown in Fig 4. It is similar to the PSS damping controller. The input signal is the speed deviation ($\Delta\omega_m$). The deviation in the duty ratio i.e. ΔD_S is taken into account as the output of damping controller. The SVEc damped controller consists of a gain block K_{SVEc} , wash out block and phase compensation block. The phase compensation block (time constants T_1 and T_2) provides the appropriate phase - lead characteristics to compensate for the phase lag between input and output signals. By varying the Damping Ratio (DR) the desired value of series compensation is obtained and it is added to the D_{Sref} . The value of reactance X_{SVEc} is automatically adjusted by varying the DR of IGBT switches. From (7), $X_{SVEc max}$ corresponds to $D_{Smax} = 1$ and, similarly $X_{SVEc min}$ corresponds to $D_{Smin} = 0$. SVEc can be modeled as a variable reactance. The equation of SVEc reactance can be defined as

$$\Delta \dot{X}_{SVEc} = -\frac{1}{T_{SVEc}} \Delta D_S - \frac{1}{T_{SVEc}} \Delta X_{SVEc} \quad (14)$$

where as ΔD_S is the deviation in the duty ratio of IGBT switches and ΔX_{SVEc} is the reactance of SVEc and T_{SVEc} is the time constant of SVEc.

Open Science Index, Electrical and Computer Engineering Vol:11, No:11, 2017 publications.waset.org/10009019.pdf

In design of COC, the 3 state variables ΔV_{Si} , ΔD_{Si} , ΔX_{SVEc_i} will be included to the A_{sys} [22].

The state variable ΔV_{Si} corresponding to PSS and ΔD_{Si} and ΔX_{SVEc_i} are the state variables of the SVEc controller. The system matrix for COC of SVEc and PSS for multi machine network is $[[A_{COC}]_{(8m+2) \times (8m+2)}]$. So, the test system eigen-values will be increased by three.

V. OPTIMAL STATE FEEDBACK CONTROLLER

The OSFC from the precedent four decades has been broadly investigated [23]. The OSFC design problem is the formulation of the cost function and the elite of the state and control weighting matrices. The main aim of OSFC is to accomplish the network highest damping efficiency and improve the system stability. The proposed Optimal Controller algorithm for COC of SVEc and PSS solves a succession of constrained nonlinear optimization so that, critical eigenvalues of the unstable and lower damped modes are transferred to the

conic region. The method is based on trial and error and does not present a systematic way of choosing Q and R. The block diagram representation of OSFC is as given in Fig. 5

Optimal Control vector is represented in the form of K matrix (K is state feedback gain matrix)

$$u(t) = -K.x(t) \quad (15)$$

The performance index as [23]

$$J = \int_0^{\infty} (x^T Q x + u^T R u) dt \quad (16)$$

where Q is state weighting matrix and R is control weighting matrix. Optimal Control matrix K is

$$K = R^{-1} . E^T . P \quad (17)$$

Work out the matrix P [23]:

$$A^T P + P A - P E R^{-1} . E^T . P + Q = 0; \quad (18)$$

The major shortfall in OSFC design approaches outlined above is the lack of systematic procedure for the design of a quadratic cost function that would reflect the physical characteristics of the network studied [24]. The performance of proposed OSFC for COC of SVEc and PSS was reviewed with without controller using MATLAB.

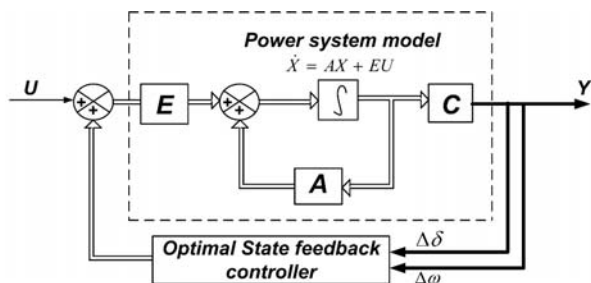

Fig. 5 Block diagram representation of OSFC

The following steps are involved in designing the OSFC

Step1. Read the system data

Step2. Convert the system data into state space

$$\dot{X} = Ax + Eu \text{ and } Y = Cx + Du$$

Step3. Assume Q,R to be positive definite matrices

Step4. Solve Matrix Riccati equation for P and K

$$A^T P + P A - P E R^{-1} E^T P + Q = 0$$

Step5. Compute optimal state feedback gain matrix(K)

$$K = R^{-1} . E^T . P$$

Step6. Plot the required parameters.

The following limitations in the OSFC were observed.

1. All states can be measured but measured parameters are not accurate.
2. Non linearity's of the system is not considered.

TABLE I
THREE LOADING CONDITIONS FOR THE SYSTEM (IN P.U)

	Case-A (Nominal Load in p.u)		Case-B (Light Load in p.u)		Case-C (Heavy Load in p.u)	
	P	Q	P	Q	P	Q
Generator						
G ₁	0.72	0.27	0.36	0.16	2.21	1.09
G ₂	1.63	0.07	0.80	-0.11	1.92	0.56
G ₃	0.85	-0.11	0.45	-0.20	1.28	0.36
Load						
A	1.25	0.50	0.65	0.55	2.00	0.80
B	0.90	0.30	0.45	0.35	1.80	0.60
C	1.00	0.35	0.50	0.25	1.50	0.60

VI. SIMULATION RESULTS AND DISCUSSIONS

WSCC 3-machine, 9-bus system [19] affected with PSS and SVEc damping controller, as presented in Fig. 6, is taken into account during this work. In this section, the performance of proposed OSFC was tested on W.S.C.C 3-machine, 9-bus system. The full data of the test system is taken from [19]. A collection of three operating conditions of generator and load is presented in Table I. The data of PSS and SVEc damping controllers can be selected as identical capacity, 0.01 is the uniform damping assumed for all 3 machines, 0.5 is the series compensation level and σ_0 is -0.5. In [22], for each machine a speed – input PSS is equipped. The input signal to the transmission line is selected as active power. The active power flow data are given in Table II. The largest power flow in line 5-7 is considered as under study. So, the best location to place the SVEc is 5-7 installed in series with the line [22].

TABLE II
BASE CASE (LINE FLOW) ON 100MVA BASE

From bus	To bus	Real power (p.u)
4	6	0.3070
6	9	0.6082
4	5	0.4094
5	7	0.8662
7	8	0.7638
8	9	0.2410

The dynamic stability of test system is examined through eigenvalue analysis and time response results at different load conditions and are reviewed in coming sections.

A. Eigen- Value Analysis

The comparative eigenvalue analysis of test system without control and with Optimal Control for COC of SVEc and PSS are carried out at different loading conditions.

Case –A

Table III presents the eigenvalues of test system in open mode and these are related to those depicted in [19]. The critical swing mode Λ_2 as $-0.1906 \pm j 8.3666$ is close to the

imaginary axis of the complex plane and has the DR of 0.0228. This mode can be slightly improved by adding COC of SVEc and PSS to the system.

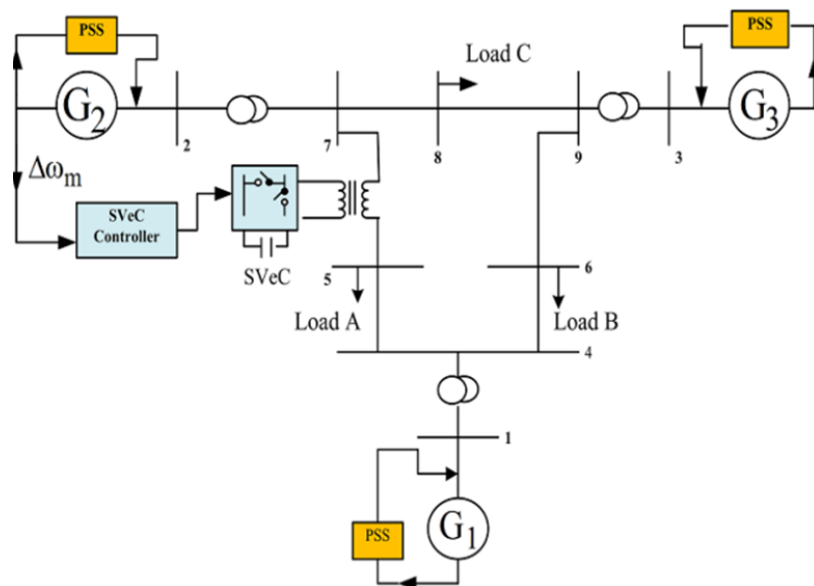

Fig. 6 Multi machine network with PSS and SVEc

The third column of Table III lists the eigenvalues of the test system when the proposed OSFC of SVEc and PSS are connected to the test system, as shown in Fig. 9. It is observed that the critical mode Λ_2 has shifted to $-0.8959 \pm j 8.8013$, and the DR is 0.1010. Hence the OSFC for COC of SVEc and PSS can improve the DR by 0.0782, respectively.

TABLE III
 EIGENVALUES FOR CASE-A LOAD

Mode	System without control	OSFC for COC of SVEc and PSS
Λ_1	$-0.7195 \pm j12.745$	$-0.8769 \pm j 12.847$
Λ_2	$-0.1906 \pm j 8.3666$ (0.0228)	$-0.8959 \pm j 8.8013$ (0.1010)
Λ_3	$-5.6804 \pm j 7.9656$	$-5.5513 \pm j 7.864$
Λ_4	$-5.3625 \pm j7.9308$	$-5.2581 \pm 7.7512i$
Λ_5	$-5.2280 \pm j 7.8259$	$-5.2411 \pm 7.8508 i$
Λ_6	$-5.1777, -3.3983$	$-9.0909, -0.1$
Λ_7	$-0.4511 \pm j 1.2003$	$-0.4243 \pm 1.2305 i$
Λ_8	$-0.4478 \pm j 0.7295$	$-0.4134 \pm 0.7414 i$
Λ_9	$-0.4362 \pm j 0.4871$	$-0.4062 \pm 0.6067 i$
Λ_{10}	0.0000, 0.0000	$-3.125, -1.0001$
Λ_{11}	-3.1250	$-9.0909, -9.1658, -9.1519, -5.1526, -3.4073, -79.4686$

Case-B

Table IV lists the eigenvalues for Case-B. In open loop, the critical mode is $-0.3944 \pm j 8.1815$, and 0.0481 is the DR. In OSFC for COC of SVEc and PSS the dominant mode shifted to $(-0.926 \pm j 10.438)$ and has DR of 0.0884. Further, additional improvement of damping in the OSFC for COC of SVEc and PSS for Case-B is around 0.0403.

Case-C

The test system presents eigenvalues for Case-C and is indexed in Table V. The critical mode in open mode is -0.200

$\pm j 8.4407$ and 0.0237 is the DR of corresponding mode. In OSFC for COC of SVEc and PSS the dominant mode shifted to $-0.5442 \pm j 9.080$ and has DR of 0.0598, respectively. Further, additional improvement of damping in the OSFC for COC of SVEc and PSSs for Case-C is around 0.0361, respectively.

It is clear from the above analysis that the OSFC for COC of SVEc and PSS can simultaneously be improved for damping LFO of test system when compared to without control.

TABLE IV
 EIGENVALUES FOR CASE-B LOAD

Mode	System without control	OSFC for COC of SVEc and PSS
Λ_1	$-1.2142 \pm j12.193$	$-1.466 \pm j 12.573$
Λ_2	$-0.3944 \pm j 8.182$ (0.0481)	$-0.926 \pm j 10.438$ (0.0884)
Λ_3	$-5.2583 \pm j7.9246$	$-5.438 \pm j 7.858$
Λ_4	$-5.2474 \pm j 7.8926$	$-5.242 \pm j 7.854$
Λ_5	$-5.1611 \pm j 7.7885$	$-5.086 \pm j 7.575$
Λ_6	$-3.9847, -2.6677$	$-5.153, -3.407$
Λ_7	$-0.4806 \pm j 1.1567$	$-0.431 \pm j 1.227$
Λ_8	$-0.4659 \pm j 0.4978$	$-0.415 \pm j 0.742$
Λ_9	$-0.4653 \pm j 0.7328$	$-0.406 \pm j 0.606$
Λ_{10}	0.0000, 0.0000	$-0.1000, -3.1250$
Λ_{11}	-3.1250	$-9.09, -79.46, -9.0909, -9.1658, -9.08, -9.1519$

B. Time Response Analysis

Time – response analysis plots the deviation in speed of generators 2 and 3 with generator 1 for compensation of series line is 50% and simulation time of 20 sec whereas ω_1, ω_2 and ω_3 are the rotor speed of machine 1, 2 and 3, respectively, and t is the time range of simulation. Table VI shows the system percentage peak overshoot and settling time of three different

loading conditions.

TABLE V
 EIGENVALUES FOR CASE-C LOAD

Mode	System without control	OSFC for COC of SVEc and PSS
Λ_1	$-0.6683 \pm j 12.9599$	$-1.466 \pm j 12.573$
Λ_2	$-0.2000 \pm j 8.4407$ (0.0237)	$-0.5442 \pm j 9.080$ (0.0598)
Λ_3	$-6.6539 \pm j 7.9750$	$-5.627 \pm j 8.357$
Λ_4	$-6.7997 \pm j 7.989$	$-6.948 \pm j 8.953$
Λ_5	$-5.2629 \pm j 7.8397$	$-7.285 \pm j 8.624$
Λ_6	$-5.2103, -3.6163$	$-4.153, -3.407$
Λ_7	$-0.4785 \pm j 1.2131$	$-9.831 \pm j 5.257$
Λ_8	$-0.5184 \pm j 0.7317$	$-0.625 \pm j 1.943$
Λ_9	$-0.6022 \pm j 0.4754$	$-0.607 \pm j 0.807$
Λ_{10}	$0.0000, -0.0000$	$-0.1000, -3.1250$
Λ_{11}	-3.1250	$-8.09, -80.57, -10.1818, -10.2676, -10.48, -10.25$

Response for Nominal Load Condition (Case-A)

Time domain simulation is performed on nominal load condition. Figs. 7 (a) and (b) show the speed deviations of generators. These figures illustrate the capability of the proposed controller in reducing the settling time and damping the low frequency oscillations. For better results the peak overshoot should be minimized with settling time. Moreover, the peak overshoot in open mode and with optimal control $\Delta\omega_{31}$ as 2.53% and 1.0%, respectively and $\Delta\omega_{21}$ is 3.95% and 2.03%. Also, the settling time of these oscillations for $\Delta\omega_{31}$ are $t_s = 19.75$ s, and 6.21 s, respectively and for $\Delta\omega_{21}$, $t_s = 19.78$ s, and 6.01 s, for without control and with OSFC for COC of SVEc and PSS.

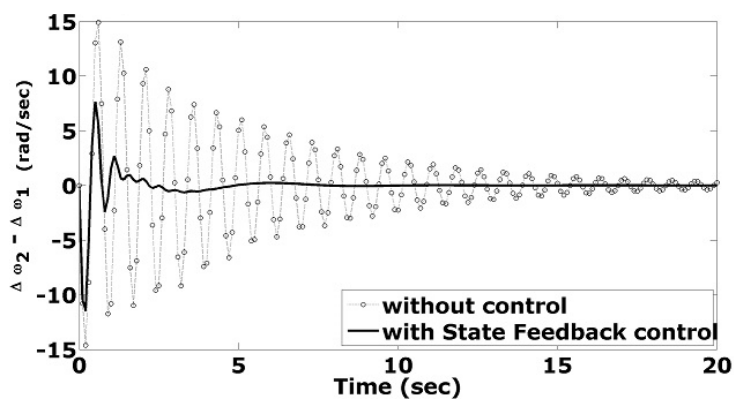

(a) Speed deviation response of $\Delta\omega_{21}$ (rad/sec)

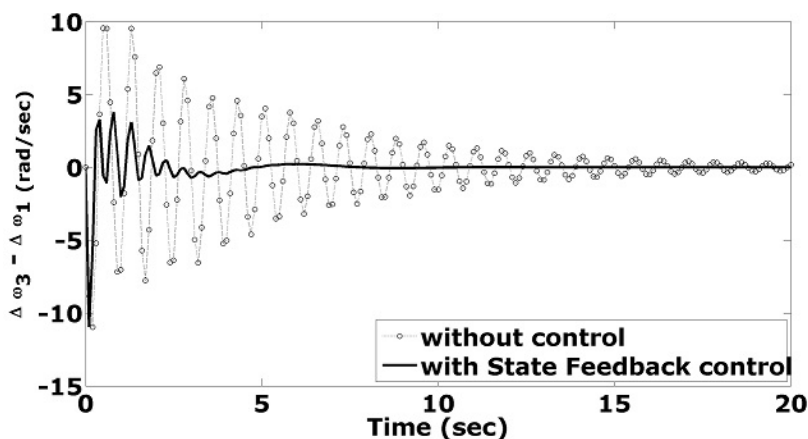

(b) Speed deviation response of $\Delta\omega_{31}$ (rad/sec)

Fig. 7 Angular velocity of the system without controller and with OSFC for Case-A

Response for Light Load Condition (Case-B)

Figs. 8 (a) and (b) show the response at light load condition. Moreover, the peak overshoots for $\Delta\omega_{31}$ are 1.81% and 1.09%, respectively and for $\Delta\omega_{21}$ 2.91% and 1.49% for without control and with OSFC for COC of SVEc and PSS. Also, the settling times of these oscillations for $\Delta\omega_{31}$ are $t_s =$

9.49 s, and 6.46 s, respectively and for $\Delta\omega_{21}$, $t_s = 10.22$ s, and 6.44 s, for without control and with OSFC for COC of SVEc and PSS. The results of these studies show that the proposed Optimal Controller for COC of SVEc and PSS has an excellent capability in damping power system oscillations.

Response for Heavy Load Condition (Case-C)

Figs. 9 (a) and (b) illustrate the response at heavy load condition. The figures illustrate that OSFC to COC has admirable damping characteristics to damp LFO compared to without controller. Moreover, the peak overshoots for $\Delta\omega_{31}$ are 2.18% and 1.09%, respectively and for $\Delta\omega_{21}$, 3.37% and

1.49%, for without control and with OSFC for COC of SVEc and PSS. Also, the settling times of these oscillations for $\Delta\omega_{31}$ are $t_s = 18.82$ s, and 6.81 s, respectively and for $\Delta\omega_{21}$, $t_s = 19.52$ s, and 6.92 s, for without control and with OSFC for COC of SVEc and PSS.

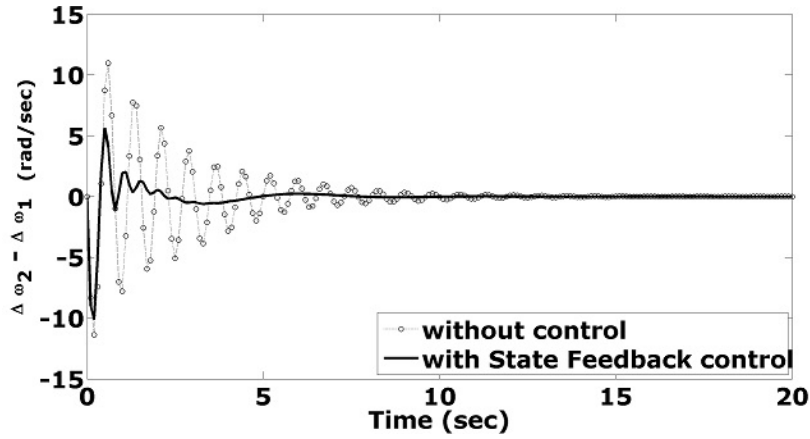

(a) Speed deviation response of $\Delta\omega_{21}$ (rad/sec)

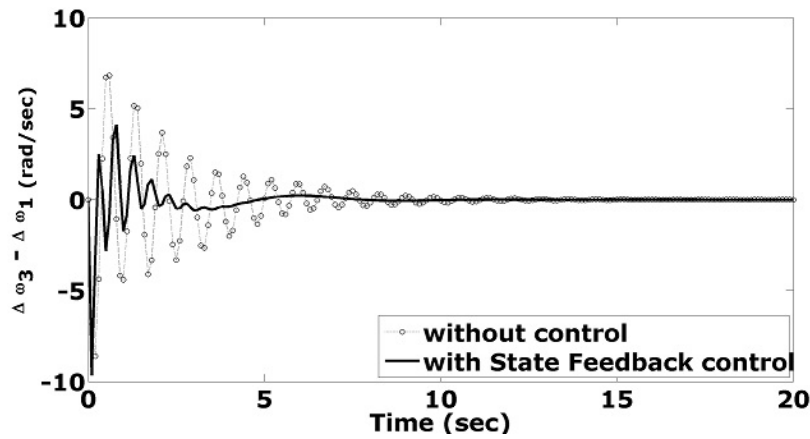

(b) Speed deviation response of $\Delta\omega_{31}$ (rad/sec)

Fig. 8 Angular velocity of the system without controller and with OSFC for Case-B

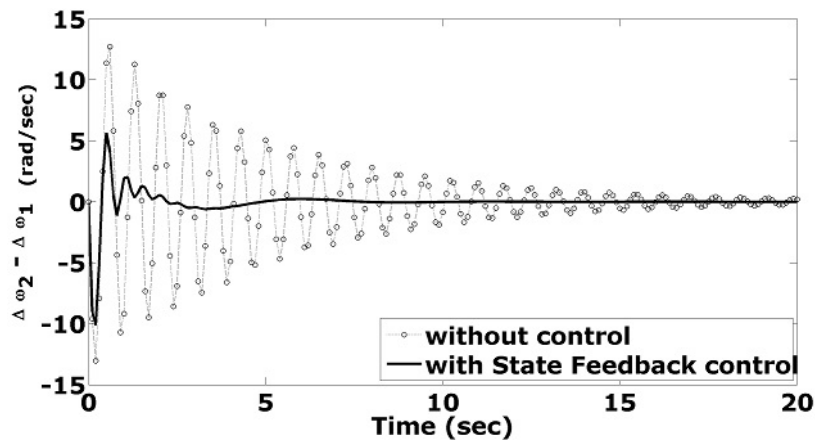

(a) Speed deviation response of $\Delta\omega_{21}$ (rad/sec)

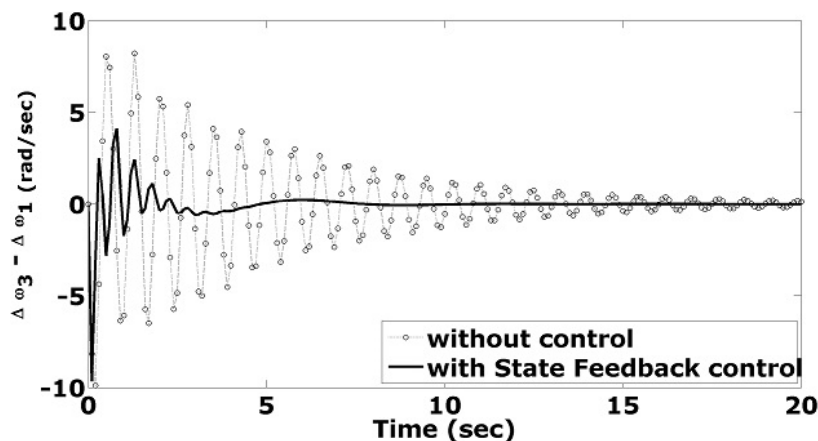

(b) Speed deviation response of $\Delta\omega_{31}$ (rad/sec)

Fig. 9 Angular velocity of the system without controller and with OSFC for Case-C

The results display that the proposed optimal control quickly mitigates the LFO in comparison with without control. The comparison of the results shows that Optimal Control has less settling time, less overshoot, less Undershoot and short time to come back to the pre-disturbance condition.

TABLE VI
PEAK OVERSHOOT AND SETTLING TIME OF RELATIVE SPEED DEVIATION OF TEST SYSTEM WITH DIFFERENT CASES

Name of the controller	% of peak overshoot (Case-A)		Settling time in Seconds (Case-A)	
	$\omega_3 - \omega_1$	$\omega_2 - \omega_1$	$\omega_3 - \omega_1$	$\omega_2 - \omega_1$
System without control	2.53%	3.95%	19.75	19.78
OSFC for COC of SVEc and PSS	1.0%	2.03%	6.21	6.01
% of peak overshoot (Case-B)		Settling time in Seconds (Case-B)		
System without control	1.81%	2.91%	9.49	10.22
OSFC for COC of SVEc and PSS	1.09%	1.49%	6.46	6.44
% of peak overshoot (Case-C)		Settling time in Seconds (Case-C)		
System without control	2.18%	3.37%	18.82	19.52
OSFC for COC of SVEc and PSS	1.09%	1.49%	6.81	6.92

VII. CONCLUSION

This paper proposes the design of Optimal Control for simultaneous COC of SVEc and PSS in order to damp low frequency oscillations in multi machine power systems. The performance of the proposed controller is compared with without controller under different loading conditions. The proposed approach is verified by means of eigenvalue analysis and time-response results. It has been revealed that the optimal control for COC of SVEc and PSS is more effective than without controller under different cases. The proposed Optimal Control can also be implemented for other series FACTS damping controllers. Our future research would be developing sliding mode controller to the COC of SVEc and PSS to damp LFO in multi machine networks under different

loading conditions.

REFERENCES

- [1] P. Kundur, "Power system stability and control", McGraw-Hill, New York, 1994, p.no.20-25,768-780.
- [2] L.A.C. Lopes and G. JoOs, "Pulse width modulated capacitor for series compensation," *IEEE Trans. Power Electronics*, vol.16, no.2, pp.167-174, March 2001.
- [3] G. Venkataramanan and B.K. Johnson, "Pulse width modulated series compensator," *IEE Proc.-Gen., Trans. and Dist.*, vol.149, no.1, pp.71-75, Jan.2002.
- [4] F. Mancilla-David, S. Bhattacharya, and G. Venkataramanan, "A comparative evaluation of series power-flow controllers using DC and AC-link converters," *IEEE Trans. Power Delivery*, vol.23, no.2, pp.985-996, Apr.2008.
- [5] J.M. González, C.A. Cañizares, and J.M. Ramírez, "Stability modeling and comparative study of series vectorial compensators," *IEEE Trans power delivery*, vol.25, no.2, April 2010.
- [6] Shakarami MR, Kazemi A, "Simultaneous coordinated tuning of SSSC-based stabilizer and PSS using quadratic mathematical programming". *Computer Sci Eng Electr Eng*, vol.17, no.2, pp.163-74, December 2010.
- [7] Zanetta LC, DA Cruz JJ. "An incremental approach to the coordinated tuning of power system stabilizers using mathematical programming", *IEEE Trans power Syst*, 20(1):895-902, 2005.
- [8] Cai. JJ, Erich I, "Simultaneous coordinated tuning of PSS and FACTS damping controllers in large power systems". *IEEE Trans Power Syst* 2005;20 (1):294-300.
- [9] Hiyama. T, Mishiro M, Kihara H, Ortmeier TH, "Coordinated fuzzy logic control for series capacitor modules and PSS to enhance stability of power system. *IEEE Trans Power Deliv* 1995;10(2):1098-104.
- [10] Ramirez JM, Castillo I. PSS and FDS simultaneous tuning. *Electr Power Syst Res*, 2004, 68(1):33-40.
- [11] Nguyen TT, Gianto R, "Neural networks for adaptive control coordination of PSSs and FACTS devices in multi-machine power system," *IET Gener Transm Distrib* 2008; 2(3):355-72.
- [12] Elices A. Rouco L, Bourles H, Margotin T, "Design of robust controllers for damping inter-area oscillations: Application to the European power system," *IEEE Trans Power Syst* 2004; 19(2):1058-67.
- [13] Farsangi M. Kyanzaeh S. Haidari S. Nezamabadi H, "Coordinated control of low-frequency oscillations using real immune algorithm with population management", *Energy Conversion and Management* 2010; 51:271-6.
- [14] CIGRE Task Force 38.02.16 Report, Paris, France; 1999.
- [15] Pilotto LAS, Alves JER, Watanabe EH., "High frequency eigenanalysis of HVDC and FACST assisted power systems" *In: IEEE power engineering society, summer meeting*; 2000, p. 823-9.
- [16] The Electric Power Research Institute (EPRI) Report TR-109969. *Analysis of control interactions on FACTS assisted power system*. Final Report, Palo Alto, CA; January 1998.
- [17] Safari, Amin, Heidar Ali Shayanfar, and Ahad Kazemi, "Coordinated

control of pulse width modulation based AC link series compensator and power system stabilizers," *Elsevier Electrical Power and Energy systems*, vol.83, pp.117-123, Dec. 2016.

- [18] H. S. Ko and J. Jatskevich, "Power Quality Control of Wind-Hybrid Power Generation System Using Fuzzy-LQR Controller," in *IEEE Transactions on Energy Conversion*, vol. 22, no. 2, pp. 516-527, June 2007.
- [19] P.W. Sauer, and M.A. Pai, "Power System Dynamics and Stability". *Prentice-Hall publisher*, New Jersey, 1st ed.1998, p.221-228, 171-173.
- [20] Truong, D. N., & Wang, L. (2013, May) "Dynamic stability enhancement of a single-machine infinite-bus system using a series vectorial compensator". In *Industrial Electronics (ISIE), 2013 IEEE International Symposium on (pp. 1-6)*.
- [21] K. Himaja, T S Surendra and S Tara Kalyani, "Coordinated design of PSS and Series vectorial compensator controllers for damping power system oscillations," *Journal of Electrical Engineering*, Vol 16, No 4, pp.507-512, Dec 2016.
- [22] Debasish Mondal, Abhijit Chakrabarti, and Aparajita Sengupta, "Power System Small Signal Stability and Control". San Diego, Academic Press, 1st ed, 2007, p.no.161-163.
- [23] S.S. Lee and J K Park, "Design of power system stabilizer using observer/sliding mode, observer/sliding mode-model following and H_{∞} /sliding mode controllers for small-signal stability study," *Elsevier Electrical Power and Energy systems*, vol.20, pp.543-553, Nov 1998.
- [24] Alok Sinha, *Linear systems optimal and robust control*, CRC press, 2007, p.no.123-132.