

Steady State Analysis of Distribution System with Wind Generation Uncertainty

Zakir Husain, Neem Sagar, Neeraj Gupta

Abstract—Due to the increased penetration of renewable energy resources in the distribution system, the system is no longer passive in nature. In this paper, a steady state analysis of the distribution system has been done with the inclusion of wind generation. The modeling of wind turbine generator system and wind generator has been made to obtain the average active and the reactive power injection into the system. The study has been conducted on a IEEE-33 bus system with two wind generators. The present research work is useful not only to utilities but also to customers.

Keywords—Distributed generation, distribution network, radial network, wind turbine generating system.

I. INTRODUCTION

HIGH penetration of distribution generation in power system transforms the passive distribution network to active distribution network, so the load flow analysis of distribution network is essential. For the analysis of distribution network, it is essential to use efficient, fast, and robust power flow method. Such a power flow method must be able to model the special feature of distribution system in details [1]-[3].

Distribution networks are radial and mesh type structure with large number of nodes and branches with unbalance power flows in both directions. There are many methods for the analysis the load flow of transmission system. There are some characteristics of distribution system which restrict the traditional load flow methods of transmission system to reach the most accurate solution of distribution system. Some of the electrical characteristics of distribution system are low X/R ratio, unbalanced distribution network, radial and weakly meshed structure, large number of nodes and branches.

Due to above characteristics, the traditional load flow methods such as Gauss-Seidel and Newton-Raphson method may not converge or can be inaccurate. In radial distribution networks, modified fast decoupled Newton Raphson method has been used in [4], [5]. However, in weakly meshed distribution network, modified fast decoupled Newton Raphson method is not applicable, so the solution of distribution network should be based upon the topology characteristic of the distribution networks. There are some methods which use the topology characteristic of the distribution network such as bus injection to branch current (BIBC) and branch current to bus voltage (BCBV) matrices. The BIBC and BCBV methods [6] are applicable for both

radial and weakly meshed structure and provide most accurate solution for distribution network and hence for active distribution network.

Today's world is facing the problem in conventional power system due to depletion in fossil fuel and increase in the environmental pollution, so the demand of non-conventional/renewable energy has been increased which transformed the passive distribution network into active distribution network [7], [8]. When the distribution generation (DG) is integration with the conventional power system, it becomes active distribution network using renewable energy sources like wind power, solar photovoltaic cells, combined heat and power system, battery power, etc. Integration of renewable energy in conventional power system increases the stability and fulfills the requirement of reactive power demand, improves the voltage profile and provides the customer satisfaction [9]-[12]. Climate is changing due to increase in temperature of environment, so there have been many conventions held on climate change like United Nation Framework Convention on Climate Change (UNFCCC), Conferences of Parties (COP) and Kyoto Protocol. The objective was to limit increment in temperature below 2 °C, so all the countries are moving towards the renewable energy sources to reduce the greenhouse gases (GHGs).

The analysis of the active distribution network is very essential as per the future aspect and the methods for solving distribution load flow must (DLF= be accurate and robust. In this paper, a DLF has been implemented using the topology characteristic of the distribution network and provides the solution more accurately and robust.

The DLF has been explained in section II and algorithms in Section III. The wind turbine generator system (WTGS) has been explained in Section IV and result and discussion in Section V.

II. DISTRIBUTION LOAD FLOW

A. Simple Distribution System Model

Let us consider a 5-bus radial distribution system with 5-branches as shown in Fig. 1. The relationship between the branch current and injected current can be obtained by applying the Kirchhoff's Current Law (KCL) in the distribution network. Branch currents are B_1, B_2, B_3, B_4, B_5 and injected currents are $I_1, I_2, I_3, I_4, I_5, I_6$ can be expressed as [6];

Zakir Husain is with the Department of Electrical Engineering NIT Hamirpur, HP, India (e-mail: zahusain2@gmail.com).

Neem Sagar and Neeraj Gupta are with the Department of Electrical Engineering NIT Hamirpur, HP, India.

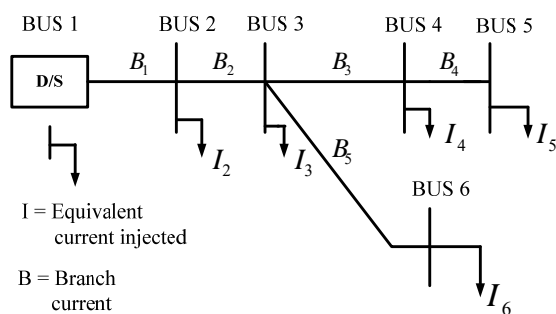

Fig. 1 Simple 6-bus distribution system

Applying the KCL in Fig. 1, we obtained the following relationship;

$$\begin{aligned} B_5 &= I_6 \\ B_4 &= I_5 \\ B_3 &= I_4 + I_5 \\ B_2 &= I_3 + I_4 + I_5 + I_6 \\ B_1 &= I_2 + I_3 + I_4 + I_5 + I_6 \end{aligned} \quad (1)$$

Relationship can be expressed in a matrix form as;

$$\begin{bmatrix} B_1 \\ B_2 \\ B_3 \\ B_4 \\ B_5 \end{bmatrix} = \begin{bmatrix} 1 & 1 & 1 & 1 & 1 & 1 \\ 0 & 1 & 1 & 1 & 1 & 1 \\ 0 & 0 & 1 & 1 & 0 & 1 \\ 0 & 0 & 0 & 1 & 0 & 1 \\ 0 & 0 & 0 & 0 & 1 & 1 \end{bmatrix} \begin{bmatrix} I_2 \\ I_3 \\ I_4 \\ I_5 \\ I_6 \end{bmatrix} \quad (2)$$

Equation (2) can be expressed as;

$$[B] = [BIBC][I] \quad (3)$$

where, BIBC = Bus injection Branch current matrix and BIBC matrix contains only 0 and 1 elements in the matrix and become an upper triangular matrix.

The relationship between the branch current and bus voltage is obtained by using KVL in Fig. 1.

$$\begin{aligned} V_1 - V_2 &= B_1 Z_{12} \\ V_2 - V_3 &= B_2 Z_{23} \\ V_3 - V_4 &= B_3 Z_{34} \\ V_1 - V_4 &= B_1 Z_{12} + B_2 Z_{23} + B_3 Z_{34} \\ V_1 - V_5 &= B_1 Z_{12} + B_2 Z_{23} + B_3 Z_{34} + B_4 Z_{45} \\ V_1 - V_6 &= B_1 Z_{12} + B_2 Z_{23} + 0 + 0 + B_5 Z_{36} \end{aligned} \quad (4)$$

V_i = Voltage of bus i, B = Branch current, Z_{ij} = Line impedance between bus i and j.

Above relationship can be expressed in a matrix form as;

$$\begin{bmatrix} V_1 \\ V_1 \\ V_1 \\ V_1 \\ V_1 \end{bmatrix} - \begin{bmatrix} V_2 \\ V_3 \\ V_4 \\ V_5 \\ V_6 \end{bmatrix} = \begin{bmatrix} Z_{12} & 0 & 0 & 0 & 0 \\ Z_{12} & Z_{23} & 0 & 0 & 0 \\ Z_{12} & Z_{23} & Z_{34} & 0 & 0 \\ Z_{12} & Z_{23} & Z_{34} & Z_{45} & 0 \\ Z_{12} & Z_{23} & 0 & 0 & Z_{36} \end{bmatrix} \begin{bmatrix} B_1 \\ B_2 \\ B_3 \\ B_4 \\ B_5 \end{bmatrix} \quad (5)$$

It can be expressed as;

$$[\Delta V] = [BCBV][B] \quad (6)$$

where BCBV = Branch current to Bus voltage matrix

From (3) and (6) we get;

$$[\Delta V] = [BCBV][BIBC][I] \quad (7)$$

$$[\Delta V] = [DLF][I] \quad (8)$$

DLF = Direct load flow. Now the complex power at bus-m can be obtained as;

$$S_m = P_m + jQ_m \quad (9)$$

$$\begin{aligned} S_m &= V_m (I_m)^* \\ I_m &= \left(\frac{S_m}{V_m} \right)^* = \left(\frac{P_m + jQ_m}{V_m} \right)^* \end{aligned} \quad (10)$$

$$I_m^k = I_m^r (V_m^k) + j I_m^i (V_m^k) = \left(\frac{P_m + jQ_m}{V_m^k} \right)^* \quad (11)$$

$$[\Delta V^{K+1}] = [DLF][I^K] \quad (12)$$

where V_m^k and I_m^k are the bus voltage and equivalent current injection of bus-m at the K^{th} iteration, respectively. I_m^r and I_m^i are the real and imaginary parts of the equivalent current injection at bus-m at the K^{th} iteration, respectively.

III. ALGORITHM FOR DISTRIBUTION LOAD FLOW

A. Algorithm for DLF

- Step1. For n-bus distribution system and m-branch sections the order of BIBC matrix is $m \times (n-1)$.
- Step2. If a line section (B_k) is located between i and j bus copy of the column of the i-th bus of the BIBC matrix to the column of the j-th bus and fill a +1 in the position of the k-th row and the j-th bus column.
- Step3. Repeat steps (2) until the line sections are included in BIBC matrix.
- Step4. For n-bus distribution system and m-branch sections the order of BCBV matrix is $(n-1) \times m$.

Step5. If a line section (B_k) is located between i and j bus copy the row of i-th bus of the BCBV matrix to the j-th bus and fill the line impedance (Z_{ij}) in the position of j-th bus row and the k-th column.
 Step6. Repeat Steps (5) until the line sections are included in BCBV matrix.

IV. WIND TURBINE GENERATOR SYSTEM

First of all, the wind data are obtained from the wind site, or if not available, it can be generated by using Weibull distribution with particular value of scale and shape parameters. The power output of turbine can be obtained by wind turbine power curve as provided by the manufacturer of particular make. From this power output, the average power can be obtained. Figs. 3 and 4 show the wind turbine power curve (with respective equation in (13)) and wind turbine generator system [13]-[17], respectively.

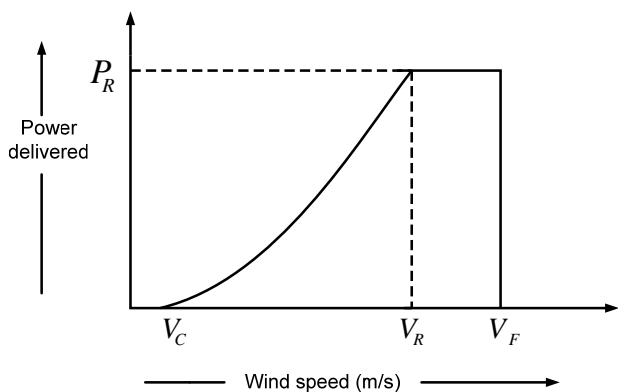

Fig. 2 Wind turbine power curve

In wind turbine power curve, the parameters are described as; P_R = Rated power output, V_R = Rated wind speed, V_C = Cut in wind speed, V_F = Furling or cut down speed.

The equation of wind turbine power curve is given as (Fig. 2);

$$P = \begin{cases} 0 & V_W \leq V_C \\ P \frac{V_W^2 - V_C^2}{V_R^2 - V_C^2} & V_C < V_W \leq V_R \\ P_R & V_C < V_W \leq V_F \\ 0 & V_W > V_F \end{cases} \quad (13)$$

A. Wind Generation Model

In this work, synchronous generator model has been used. The active power can be obtained from wind turbine power curve and reactive power can be obtained as

$$Q = P \sqrt{\frac{1 - \cos^2 \theta}{\cos \theta}} \quad (14)$$

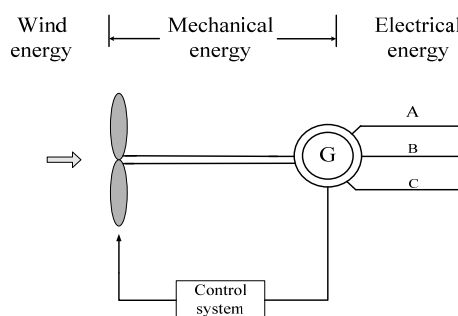

Fig. 3 Wind turbine generating system

V. RESULTS AND DISCUSSION

For the analysis of this system, a IEEE-33 distribution bus system has been used in Fig. 5. The wind generator has been installed at the voltage deficient nodes 18 and 33. First of all, the wind is obtained from the site or is generated by using with scale parameters 6 and 8.5 and shape parameters 2 in both the cases as shown in Fig. 6.

The power output is obtained by using wind turbine power curve provided by the manufacturer in which the cut in, rated, and cut out speed of wind turbine power curve are, $V = 3$ m/s, $V = 15$ m/s and $V = 25$ m/s. The rated value of wind turbine has been taken as 1 MW in all the cases. Now, the average value of the power obtained is the active power, and reactive power is obtained from (13). The active power is used in the load flow as negative P which means that it is generating, and the reactive power is introduced in load flow as +Q which means that the power is demanded by the wind generator system.

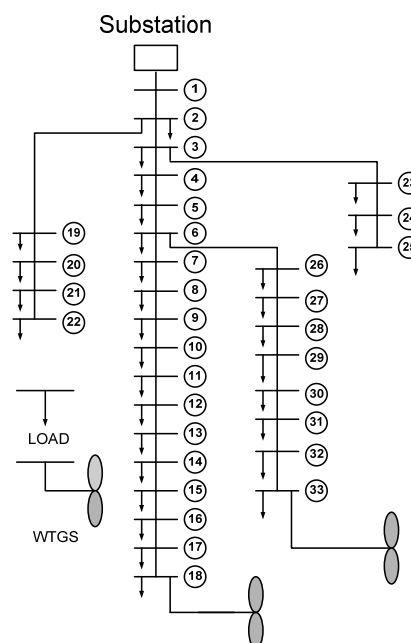

Fig. 4 IEEE-33 bus distribution system

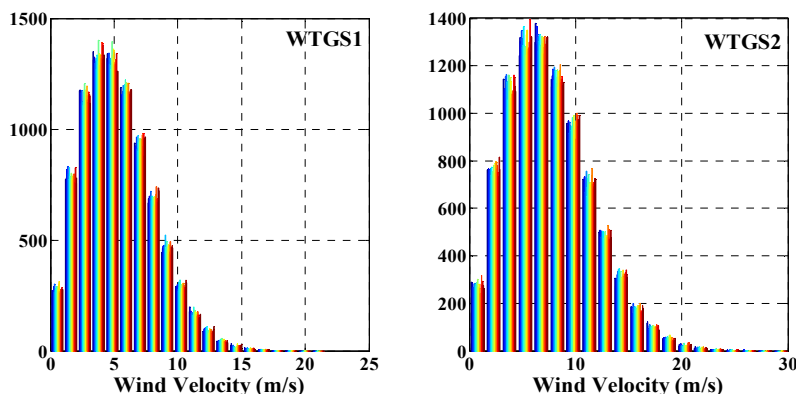

Fig. 5 Wind speed distribution at bus no. 18 and 33.

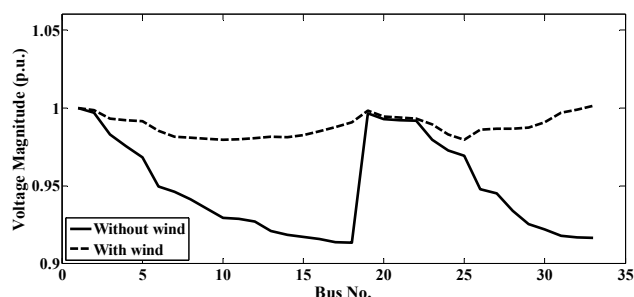

Fig. 6 Voltage profile of the system

TABLE I
VOLTAGE OF THE SYSTEM WITH AND WITHOUT WIND

Bus No.	Without Wind (p.u)	With Wind (p.u)
1	1.0000	1.0000
2	0.9970	0.9986
3	0.9829	0.9931
4	0.9755	0.9920
5	0.9755	0.9913
6	0.9497	0.9852
7	0.9462	0.9816
8	0.9414	0.9810
9	0.9351	0.9800
10	0.9294	0.9794
11	0.9286	0.9797
12	0.9271	0.9804
13	0.9210	0.9815
14	0.9187	0.9813
15	0.9173	0.9826
16	0.9159	0.9850
17	0.9139	0.9877
18	0.9133	0.9907
19	0.9965	0.9981
20	0.9929	0.9945
21	0.9922	0.9938
22	0.9938	0.9932
23	0.9794	0.9895
24	0.9727	0.9829
25	0.9694	0.9796
26	0.9478	0.9858
27	0.9452	0.9868
28	0.9338	0.9867
29	0.9255	0.9874
30	0.9220	0.9906
31	0.9178	0.9967
32	0.9169	0.9988
33	0.9166	1.0012

After the load flow has been conducted on 33-bus system using WTGS, this is a sustainable improvement in voltage profile of the system as shown in Fig. 7 with wind and without wind. From Fig. 7, it is seen that the voltages at all the nodes in radial distribution system with WTGS are within the permissible range ($V_{min}=0.95$, $V_{max}=1.05$). The corresponding values of voltages are tabulated in Table I, Fig. 6.

The increase in voltage profile is due to the reduction in line losses, due to injection of active distribution system, e.g. Wind in traditional passive distribution network.

VI. CONCLUSION

This DLF method has been implemented along with the WTGS for the efficient steady state analysis of the system. Two synchronous generator models have been used for the study in IEEE-33 bus distribution network system. There is a reduction in the line losses and improvement of the voltage profile of whole system by making distribution system active.

REFERENCES

- [1] K. A. Birt, J. J. Graffy, J. D. McDonald, and A. H. El- Abiad, "Three phase load flow programme", *IEEE Trans. Power App. Syst.*, vol. PAS-95, pp.59-65, Jan. 1976.
- [2] T. H. Chen, M. S. Chen, K.-J. Hwang, P. Kotas, and E. A. Chebli, "Distribution system power flow analysis A rigid approach", *IEEE Trans. Power Delivery*, vol. 6, pp. 1146-1152, July 1991.
- [3] B. Scott and Alsac, "Fast decoupled load flow", *IEEE Trans Power Appar. Sys.* vol 93, pp.859-869, May/June 1974.
- [4] R. D. Zimmerman and H. D. Chiang, "Fast decoupled power flow for unbalanced radial distribution systems", *IEEE Trans. Power Syst.*, vol. 10, pp. 2045-2052, Nov. 1995.
- [5] Brain Stott "Review of Load-Flow Calculation Methods", Proceedings of the IEEE, 62, (7), pp.916-929, 1974.
- [6] Michline Rupa, J. A., Ganesh, S., "Power flow analysis for radial distribution system using backward/forward sweep method", *Int. J. Electr. Commun. Eng. Electron. Commun. Eng.*, vol.8, pp. 1622-1625, 2014.
- [7] D. Das, D. P. Kothari, and A. Kalam, "Simple and efficient method for load flow solution of radial distribution networks", *International Journal of Electrical Power & Energy Systems*, vol. 17, no. 5, pp. 335 - 346, 1995.
- [8] W. C. Wu and B. M. Zhang, "A three-phase power flow algorithm for distribution system power flow based on loop-analysis method", *International Journal of Electrical Power & Energy Systems*, vol. 30, no. 1, pp. 8 - 15, 2008.
- [9] B. V. Solanki, K. Bhattacharya, C. A. Canizares, "Integrated Energy Management System for Isolated Microgrid", *IEEE Power System*

- Computation Conference*, pp.1-7, 2016.
- [10] S. Kotra & M. K. Mishra, "Energy Management of Hybrid Microgrid with Hybrid Energy Storage System", *IEEE International Conference on Renewable Energy Research and Applications*, pp. 856-860, 2015.
- [11] S. Rangnekar Khare, A. Mittal, A., & P. Suhane, "Sizing and performance analysis of standalone wind-photovoltaic based hybrid energy system using ant colony optimization", *IET Renewable Power Generation*, vol 10(7), pp.964–972, 2016.
- [12] B. Luis, & E. Zubieta "Are Microgrids the Future of Energy? DC Microgrids from Concept to Demonstration to Deployment" *IEEE Electrification Magazine*, vol.4, pp. 37-44, 2016.
- [13] L Xu, Y Wang, "Dynamic modeling and control of DFIG-based wind turbines under unbalanced network conditions", *IEEE Trans. Power Syst.*, vol. 22, no.1, pp. 314-323, Feb. 2007.
- [14] T. F. Chan, L. L. Lai, "Single-Phase Operation of a Three-Phase Induction Generator Using a Novel Line Current Injection Method", *IEEE Trans. Energy Conversion*, vol. 20, no. 2, pp. 308-315, June 2005.
- [15] T. F. Chan, L. L. Lai, "A novel excitation scheme for a stand-alone three-phase induction generator supplying single-phase loads", *IEEE Trans. Energy Conversion*, vol. 19, no. 1, pp. 136-143, Mar. 2004.
- [16] E. G. Marra and J. A. Pomilio, "Induction generator based system providing regulated voltage with constant frequency", *IEEE Trans. Ind. Electron.*, vol. 47, no. 4, pp. 908–914, Aug. 2000.
- [17] S. N. Mahato, S. P. Singh, M. P. Sharma, "Capacitors Required for Maximum Power of a Self-Excited Single-Phase Induction Generator Using a Three-Phase Machine", *IEEE Trans. Energy Conversion*, vol.23, no.2, pp. 372-381, June 2008.