

# Proximity-Inset Fed Triple Band Antenna for Global Position System with High Gain

The Nan Chang, Ping-Tang Yu, Jyun-Ming Lin

**Abstract**—A triple band circularly polarized antenna covering 1.17, 1.22, and 1.57 GHz is presented. To extend to the triple-band operation, we need to add one more ring while maintaining the mechanism to independently control each ring. The inset-part in the feeding scheme is used to excite the band at 1.22 GHz, while the proximate-part of the feeding scheme is used to excite not only the band at 1.57 GHz but also the band at 1.17 GHz. This is achieved by up-vertically coupled with one ring to radiate at 1.57 GHz and down-vertically coupled another ring to radiate at 1.17 GHz. It is also noted that the inset-part in our feeding scheme is by horizontal coupling. Furthermore, to increase the gain at all three bands, three air-layers are added to make the total height of the antenna be 7.8 mm. The total thickness of the three air-layers is 3 mm. The gains of the three bands are all greater than 5 dBiC after adding the air-layers.

**Keywords**—Circular polarization, global position system, triband antenna, high gain.

## I. INTRODUCTION

Circularly polarized (CP) microstrip antennas are widely used to receive the satellite signal. Among them, the dual-band CP antennas are relatively easier to design than the triple band antenna. The triple band CP antenna may find applications to cover two bands in the Compass Navigation Satellite System (CNSS) and one band in the Global Position System (GPS) [1]. Within the GPS spectrum, there are three bands, namely the L1 (1.575 GHz), L2 (1.227 GHz) and L5 (1.176 GHz) [2]. As the frequency ratio among the bands is small, it may increase the difficulty to design the antenna with a single-feed. In [2], three truncated square patches are stacked and are fed by a coaxial. Except for the coaxial feed, the aperture-coupled and the proximate-coupled feeds can separate the radiator and the feed and are also widely used to excite many microstrip antennas. In [3], we have introduced the proximate-inset method which combines the proximate feed [4] and the inset feed [5] in a simple way so that two-stacked radiators on a two-layer substrate can easily be excited.

In this paper, we extend the proximate-inset method to excite three stacked radiators in a three-layer substrate by a single feed. The single feed is connected to the middle circular patch so that coupling in the horizontal direction is inherently realized through (coplanar) inset coupling. However, the single feed is also inherently coupled to the other two radiations in the two vertical directions (up and down directions).

The method is applicable to both linearly and CP antennas. In our study, the method is very easy to excite three linearly polarized waves with narrow frequency ratio. The excitation for

three CP waves becomes a little difficult when the frequency ratio is too small. Nevertheless, we would like to present some research results that so far we have achieved as we think that the proximity-inset feed should deserve some attentions. In this paper, another focus is to increase the gain of the antenna, which has been addressed in [3], but is now realized.

## II. DESCRIPTION OF THE ANTENNA

Fig. 1 shows the prototype of a linearly polarized triple-band antenna fed by the proximate-inset method. In this figure, three air-layers are added to optionally increase the gain of each band. The thickness of each air-layer is 1 mm ( $h_2=h_4=h_6=1$  mm). Except for the air-layers, there are three FR4 substrates. On the upper surface of the top-substrate, there is a small circular patch with radius of  $R_1$  to response for radiation at 1.57 GHz. A stub is attached to this small circular patch to improve the match as suggested in [3]. The middle circular patch and the bottom circular patch are respectively etched on the upper surfaces of the middle-substrate and on the upper surface of the bottom-substrate. The radii of the middle circular patch and the bottom circular patch are respectively  $R_2$  and  $R_3$ . They are respectively responsible for radiation at 1.22 GHz and 1.17 GHz.

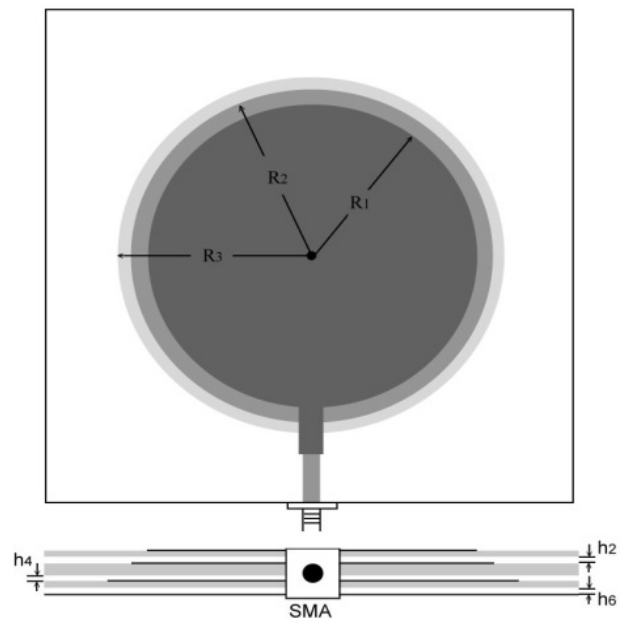

Fig. 1 The prototype of the linearly polarized triple band antenna

It is shown in Fig. 2 that a single coaxial is connected to the middle patch. Figs. 2-4 show respectively the layout patterns

The Nan Chang is with the Tatung University, Taiwan (e-mail: tnchang@ttu.edu.tw).

used to generate three circularly-polarized waves. We simply perturb each ring in proper position from the layout in Fig. 1.

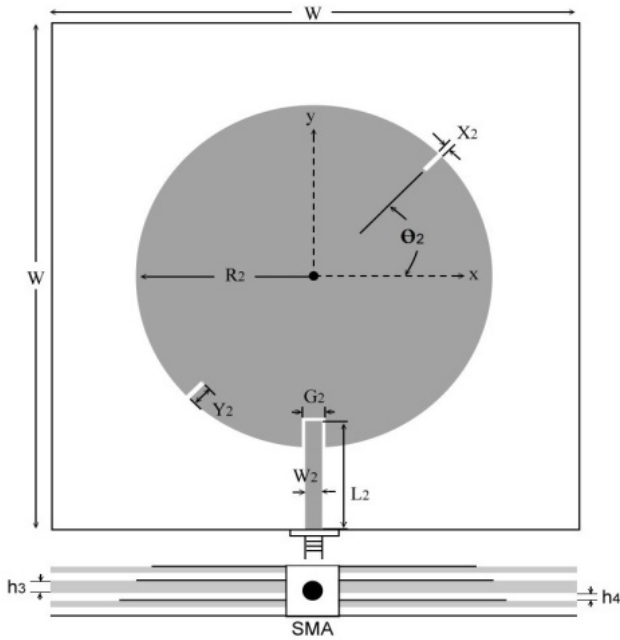

Fig. 2 The feed is horizontally coupled to the middle patch

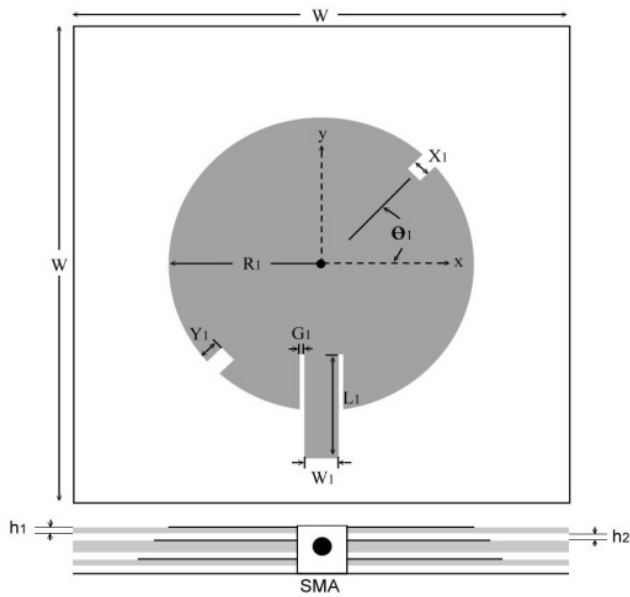

Fig. 3 The feed is upward-vertically coupled to the top patch

The perturbed values of  $x_i$  and  $y_i$  ( $i=1,2,3$ ) are shown in Table I along with other main parameters. The angles of  $\Theta_1$ ,  $\Theta_2$ , and  $\Theta_3$  are respectively  $53^\circ$ ,  $30^\circ$ , and  $135^\circ$ . It is also noted in Fig. 4 that the perturbation is obtained by attaching the stubs instead of cutting slots. We also note from Fig. 3 that a stub is inset to the top patch for impedance match.

### III. MEASUREMENTS

The proposed antenna is fabricated and tested. A picture of the fabricated antenna is shown in Fig. 5.

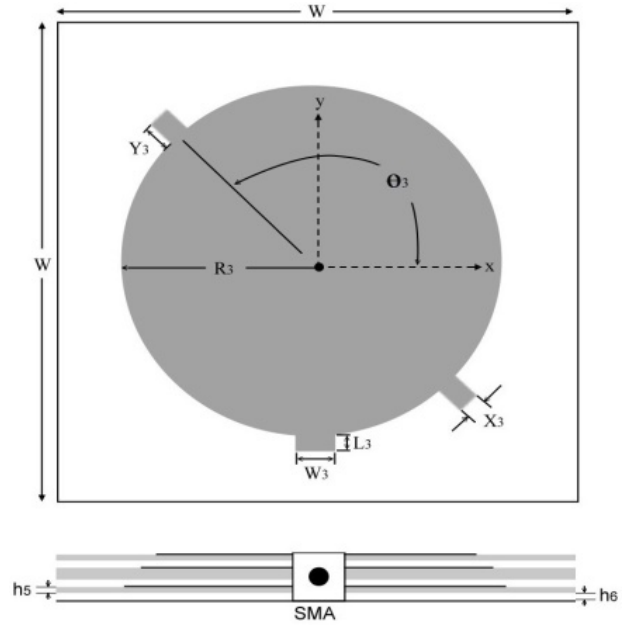

Fig. 4 The feed is downward-vertically coupled to the bottom patch

TABLE I  
 MAIN PARAMETERS OF THE ANTENNA

R1	R2	R3	X1	Y1	X2	Y2	X3	Y3
38.6	46.4	56.8	4	6	1.2	11.5	5.2	9
L1	L2	L3	G1	G2	W1	W2	W3	W
31.6	42	3.4	0.8	4.5	9.2	4.5	14	150

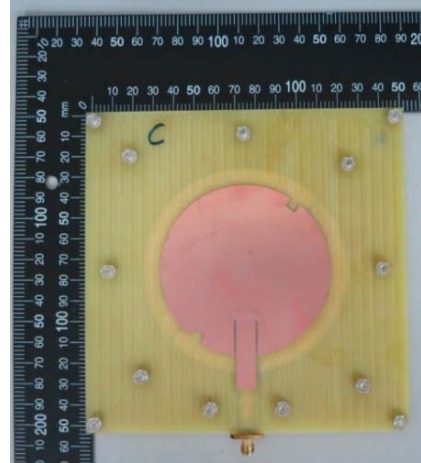

Fig. 5 The fabricated antenna

The thickness of the top substrate, the middle substrate and the bottom substrate are respectively  $h1=0.8$  mm (see Fig. 3),  $h3=1.6$  mm (see Fig. 2) and  $h5=0.8$  mm (see Fig. 4). It is shown in Fig. 6 that the measured return-loss bandwidths are 1.153 GHz-1.185 GHz, 1.215 GHz-1.223 GHz, and 1.553 GHz-1.593 GHz, respectively. Two closely resonant frequencies are clearly observed on each band in the measured results. It is suggested that three CP waves can be excited. In Fig. 7, the axial ratios in the boresight direction are presented. A slight frequency shift in the best axial-ratio value in the 1.17 GHz band is also noted.

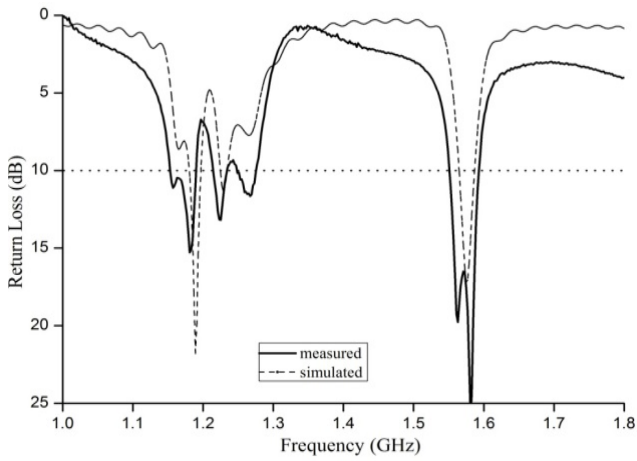

Fig. 6 Simulated and the measured return-loss of the antenna

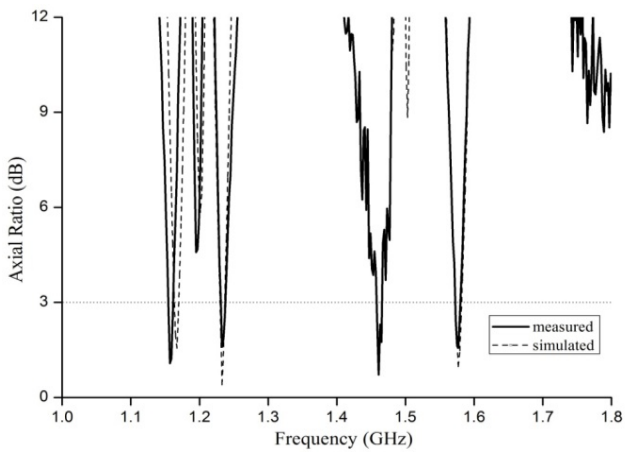

Fig. 7 Simulated and the measured axial-ratio of the antenna

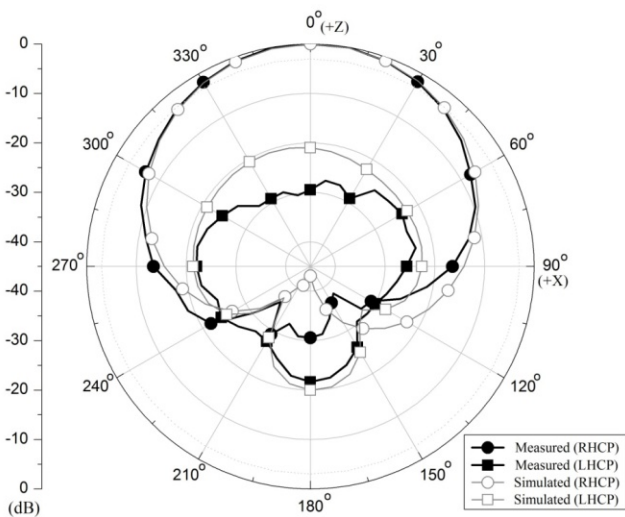

Fig. 8 Simulated and the measured patterns of the antenna at 1.176 GHz

The simulated and measured patterns in xy-plane are shown in Figs. 8-10 respectively for 1.176 GHz, 1.227 GHz, and 1.575 GHz. They are all right-hand polarized. The gain responses of the antenna are shown in Fig. 11. They are greater than 5 dBiC

for all bands.

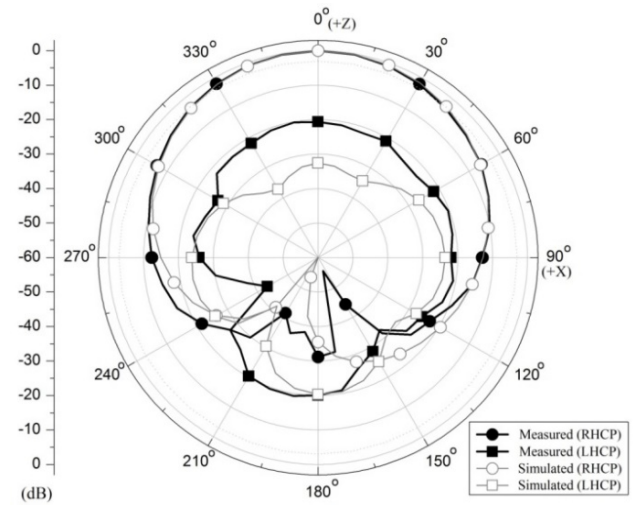

Fig. 9 Simulated and the measured patterns of the antenna at 1.227 GHz

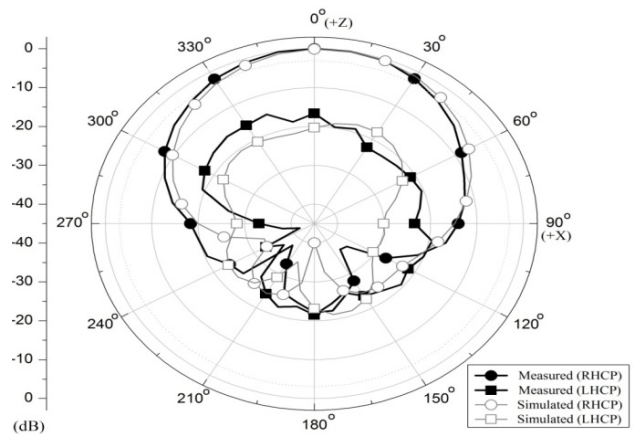

Fig. 10 Simulated and the measured patterns of the antenna at 1.5765 GHz

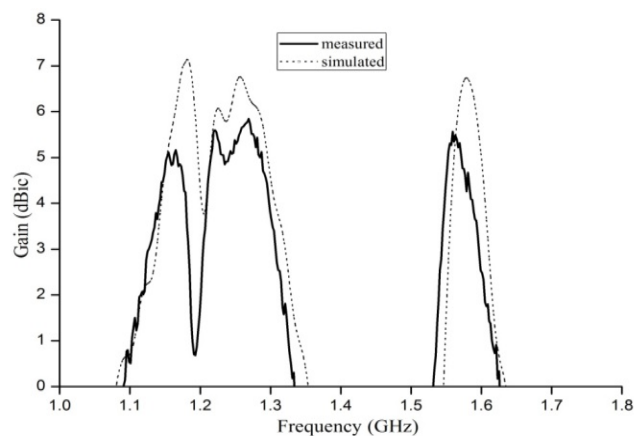

Fig. 11 Simulated and measured gain of the antenna

#### IV. CURRENT DISTRIBUTION

At 1.176 GHz, the ring with the largest radius of R3 is

responsible for the radiation. It is clearly shown in Fig. 12 that the current flows in a counter clock-wise direction. At 1.227 GHz, the current on the surface of the middle ring is highlighted as shown in Fig. 13. The current is not easily distinguished from the current from the bottom surface below the middle ring. They are mixed together. However, the net current also flows in the counter clock-wise direction. The current distribution shown in Fig. 14 reveals that it also flows in the counter clock-wise direction at 1.575 GHz. At this frequency, the current density near the loaded stub is also high. Since the current all flows in the counter clock-wise direction at the three frequencies, it is again confirmed that the antenna radiates the right-hand CP wave in the boresight direction.

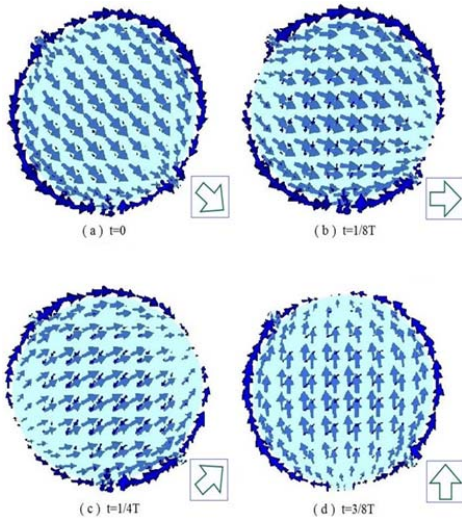

Fig. 12 The current distribution on the surface of the largest ring

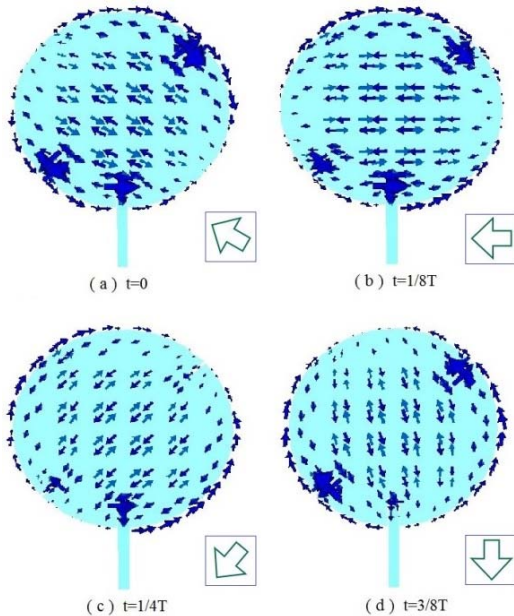

Fig. 13 The current distribution on the surface of the middle ring with radius of  $R_2$

## V. CONCLUSION

The three stacked radiators have successfully excited by the proximity-inset feed. In this paper, we initially determine  $R_1$  and  $R_2$ . Then,  $R_3$  is determined by fixing  $R_1$  and  $R_2$ . As the frequency ratio between 1.17 GHz and 1.22 GHz is small,  $R_3$  is tuned by slightly varying the thickness of the bottom substrate. The thickness of the bottom substrate is 1.6 mm and it is 0.8 mm for the top and the middle substrates. Three distinctive modes can easily be generated this way. In the proposed method, the impedance match can be realized by adding stub to the radiator. In this report, stubs are added to the top patch and also to the bottom patch. As the impedance can separately be tuned this way for each band, the match is easier realized. In terms of gain enhancement, the use of air-layers is found very useful. The three-way coupling is inherently suitable to develop the high-gain tri-band antenna. The terms of up-vertical, down-vertical, and horizontal couplings are used for easily separate the three couplings inherently existed in the proximity-inset feed.

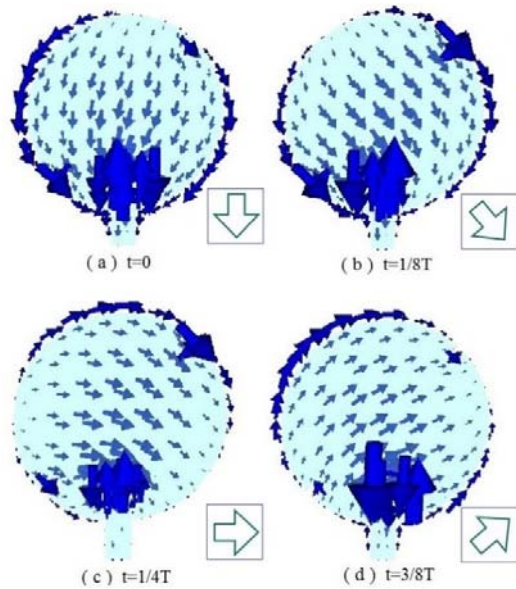

Fig. 14 The current distribution on the surface of the smallest ring

## REFERENCES

- [1] Wen Liao, Qing-Xin, and Shu Du, "Tri-band circularly polarized stacked microstrip antenna for GPS and CNSS applications", *ICMMT 2010 Proceedings*, pp. 252-255.
- [2] Kush Agarwal, Naasimuddin, and Arokiaswami Alphones, "Triple-band compact circularly polarized stacked microstrip antenna over reactive impedance meta-surface for GPS applications", *IET Microw. Antennas Propag.*, Vol.8, ISS.13, pp.1057-1065.
- [3] The-Nan Chang and Jyun-Ming Lin, "Dual-band global positioning system antenna fed by the proximity-inset method" *The Journal of Engineering*, accepted on 13<sup>th</sup> June 2017 doi: 10.1049/joe.2017.0048.
- [4] D. M. Pozar, and S. M. Voda, "A rigorous analysis of a microstripline fed patch antenna", *IEEE Trans. Antennas Propag.*, Vol. 35, No. 12, pp. 1343-1346, Dec. 1987.
- [5] W. Menzel, and S. Holzwarth, "A four-element microstrip patch antenna array with compact feed structure", *28th European Micro. Conf., Amsterdam*, 1998, pp. 167-171.