

# Sliding Mode Control of an Internet Teleoperated PUMA 600 Robot

Abdallah Ghoul, Bachir Ouamri, Ismail Khalil Bousserhane

**Abstract**—In this paper, we have developed a sliding mode controller for PUMA 600 manipulator robot, to control the remote robot a teleoperation system was developed. This system includes two sites, local and remote. The sliding mode controller is installed at the remote site. The client asks for a position through an interface and receives the real positions after running of the task by the remote robot. Both sites are interconnected via the Internet. In order to verify the effectiveness of the sliding mode controller, that is compared with a classic PID controller. The developed approach is tested on a virtual robot. The results confirmed the high performance of this approach.

**Keywords**—Internet, manipulator robot, PID controller, remote control, sliding mode, teleoperation.

## I. INTRODUCTION

THE control of robotic manipulators is a mature yet fruitful area for research, development, and manufacturing. Industrial robots are basically positioning and handling devices. Therefore, a useful robot is one that is able to control its movement and the interactive forces and torques between the robot and its environment [1].

The problem of the controlling a manipulator robot can be formulated like the determination of the evolution of the generalized forces (forces or torques) that the actuators must exert to guarantee the execution of the task while satisfying certain criteria of performance. Various techniques are used to control the manipulator arms. The mechanical design of the manipulator arm has an influence on the choice of the control diagram. A robot manipulator is a complex mechanical structure whose inertias compared to the axes of the articulations vary not only according to the load but also according to the configuration, speeds and of accelerations [2].

In order to control systems that are not linear or have non-constant parameters, the classical control laws may be insufficient because they are not robust especially when the precision requirements and other dynamic characteristics of the systems are strict. It is necessary to call control laws that are insensitive to parameter variations, perturbations and nonlinearities [4].

Several tools are proposed in the literature, including fuzzy logic, sliding control and neural networks.

The sliding mode control is a method that changes the dynamics of system by control structures. This method is designed to ensure that trajectories move to a switching condition. Therefore, the ultimate trajectory will not exist entirely within one control structure. The state-feedback control law is not a continuous function of time. Instead, it

Abdallah Ghoul is with the Bechar University, Algeria (e-mail: alla82\_gh@yahoo.fr, abdallah.ghoul@univ-bechar.dz).

Bachir Ouamri and Ismail Khalil Bousserhane are with the Bechar University, Algeria (e-mail: ouamri.b@gmail.com, bou\_isma@yahoo.fr).

switches from one continuous structure to another based on the current position in the state space. Hence, sliding mode control is a variable structure control method. The multiple control structures are designed so as to ensure that trajectories always move towards a switching condition. Instead, the ultimate trajectory will slide along the boundaries of the control structures. The motion of the system as it slides along these boundaries is called a sliding mode and the geometrical locus consisting of the boundaries is called the sliding (hyper) surface [5].

Teleoperation systems are extremely important in humans modern life. Nowadays the teleoperation systems are not only considered to be used in hazardous environments or to move toxic materials. Teleoperation systems are widely used all around the world in various applications from space applications to entertainment applications. To have an ability to control something remotely has a strong impact in the business sector as well, as it is lowering the costs. There is a strong demand for teleoperation process improvement, and the main trend is to reduce the operators share on the control process and increase the teleoperators share or any other virtual operators share instead [3].

The media of communication mainly is radio, microwave, network, etc., before. However, with the development of the Internet, the advantages of the Internet, like extensive distribution, easy to access, emerge gradually. So the Internet-based teleoperation have got much attraction [6].

## II. SLIDING MODE CONTROLLER DESIGN

### A. PUMA 600 Manipulator Properties

The PUMA 600 robot is a robot with six articulations but in this paper we consider just the first three joints (3 DOF robot). The Euler-Lagrangian dynamic equations for n-link manipulators are well known and can be written as [7]:

$$M(q)\ddot{q} + C(q, \dot{q})\dot{q} + G(q) = \Gamma \quad (1)$$

The matrices M and C, which summarize the properties of inertia of the manipulator, have the properties:

- $M(q)$  (matrix of inertia), is symmetric, bounded, positive definite matrix.
- A suitable definition of  $C(q, \dot{q})$  (vector of Coriolis forces and centripetals) makes matrix  $(M - 2C)$  skew-symmetric.
- $\|C(q, \dot{q})\| \leq v_0 \|\dot{q}\|$ ,  $v_0$  is independent of  $q$ .
- $\|G(q)\| \leq g_b(q)$ ,  $g_b$  is a scalar function.

### B. Problem Formulation

The following problem is considered: for an initial state  $(q(t_0), \dot{q}(t_0))$ , and a desired position  $q_d$  for a speed  $\dot{q}_d = 0$  we must find a command that can stabilize the manipulator in the final position, ie  $\lim_{t \rightarrow \infty} q(t) = q_d$ , and  $\lim_{t \rightarrow \infty} \dot{q}(t) = 0$ . Let's take the position error:

$$\begin{aligned} e(t) &= q_d - q(t) \\ \dot{e}(t) &= -\dot{q}(t) \end{aligned} \quad (2)$$

Therefore, the goal of the control is to make the vector  $(e(t), \dot{e}(t))$  tends towards 0.

### C. Determination of the Sliding Surface

The sliding surface is selected as follows [8]:

$$s = \left( \lambda + \frac{\partial}{\partial t} \right)^{r-1} e(t), \quad \lambda > 0. \quad (3)$$

The relative degree of the system (1) is  $r = 2$ , the equation of the sliding surface  $s(e, \dot{e})$  becomes:

$$s = \lambda e(t) + \dot{e}(t) \quad (4)$$

hence,

$$\begin{aligned} \dot{s} &= \lambda \dot{e}(t) + \ddot{e}(t) \\ \dot{s} &= \lambda(\dot{q}_d - \dot{q}) + (\ddot{q}_d - \ddot{q}) \\ \dot{s} &= -\lambda \dot{q} - \ddot{q} \end{aligned} \quad (5)$$

### D. Controller Design

Based on the above sliding surface, the goal is to find a control law that leads the surface  $s$  towards zero in a finite time. For the model of the system (1), the sliding mode controller(SMC) which converges the tracking errors to zero in a finite time is given as follows [10]:

$$\begin{aligned} \Gamma &= \Gamma_{eq} + \Gamma_c \\ \Gamma &= \Gamma_{eq} - k \cdot \text{sign}(s(x)) \end{aligned} \quad (6)$$

knowing that:

$\Gamma_e$  : is the equivalent command.

$\Gamma_c$  : is the switching command.

$k_i$  : est is a positive constant.

sign : is the sign function.

A method that reduces the friction effect is to replace the sign function with a saturation function. The control law becomes:

$$\Gamma = \Gamma_{eq} - k \cdot \text{sat}(s/\xi) \quad (7)$$

We pose:  $\Xi = s/\xi$ , and  $\Phi = \xi/2$

The saturation function can be defined as follows:

$$\text{sat}(s/\xi) = \begin{cases} \text{sign}(s/\xi) & ;\text{if } |\Xi| \geq \Phi \\ s/\xi & ;\text{if } |\Xi| < \Phi \end{cases} \quad (8)$$

Therefore, by substituting (8) into (7) we obtain:

$$\Gamma = \begin{cases} \Gamma_{eq} + k \cdot \text{sign}(\Xi) & ;\text{if } |\Xi| \geq \Phi \\ \Gamma_{eq} + k \cdot (\Xi) & ;\text{if } |\Xi| < \Phi \end{cases} \quad (9)$$

The equivalent command  $\Gamma_{eq}$  satisfies the condition  $\dot{s} = 0$

$$\dot{s} = -\lambda \dot{q} - \ddot{q} \quad (10)$$

$$\dot{s} = -\lambda \dot{q} - M^{-1}(q) [(\Gamma_{eq} + \Gamma_c) - C(q, \dot{q})\dot{q} - G(q)] \quad (11)$$

During sliding mode: ( $\dot{s} = 0; \Gamma_c = 0$ ) [9], then:

$$-\lambda \dot{q} - M^{-1}(q) [\Gamma_{eq} - C(q, \dot{q})\dot{q} - G(q)] = 0 \quad (12)$$

hence,

$$\Gamma_{eq} = [C(q, \dot{q}) - \lambda M(q)] \dot{q} + G(q) \quad (13)$$

By replacing in (9) we obtain the complete control law:

$$\begin{aligned} \Gamma &= [C(q, \dot{q}) - \lambda M(q)] \dot{q} + G(q) + k \cdot \text{sign}(\Xi) ;\text{if } |\Xi| \geq \Phi \\ \Gamma &= [C(q, \dot{q}) - \lambda M(q)] \dot{q} + G(q) + k \cdot (\Xi) ;\text{if } |\Xi| < \Phi \end{aligned} \quad (14)$$

finally,

$$\Gamma = [C(q, \dot{q}) - \lambda M(q)] \dot{q} + G(q) + k \cdot \text{sat}(s/\xi) \quad (15)$$

The Block diagram of sliding mode controller is given as follows:

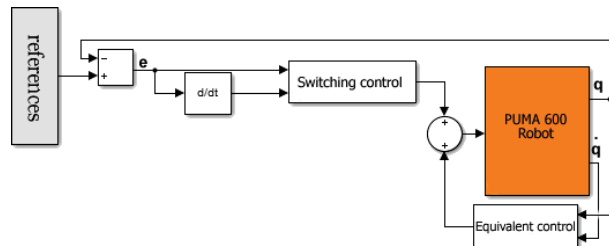

Fig. 1 Block diagram of Sliding mode controller

The Block diagram of PID controller is given as follows:

### E. Simulation Results

The figures show the simulation results of position tracking and speed tracking obtained by the application of the SMC on the PUMA 600 robot, the results of the SMC are compared with the results obtained when the PID control is applied.

The following simulation parameters were used:  $\lambda = 55$ ;  $\xi = 0.0001$ ;  $K = [1 \ 2.5 \ 1]^T$ .

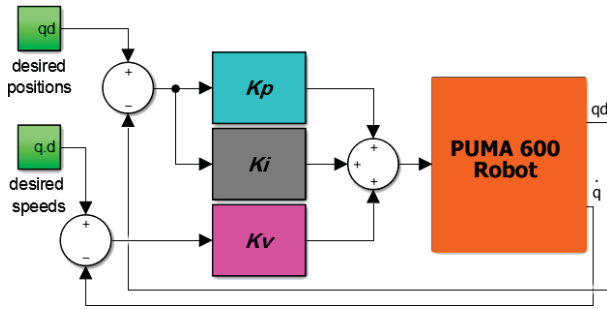

Fig. 2 Block diagram of PID controller

The figures show the efficiency of SMC and its robustness considering the faster convergence of positions/speeds tracking to the desired positions/speeds, which clearly means the high precision and stability of this controller as shown in Figs. 3-8.

We notice that the robot reaches the desired positions after a short delay and the tracking errors tend towards zero as seen in Fig 10 as well as the sliding surfaces as shown in Fig. 9.

From control viewpoint, we clearly notice the difference between the response obtained by SMC and that obtained by PID control. The SMC reduced the response time without reducing the robustness of the system. The final positions are reached when the sliding surfaces become zero. The various tests carried out on several positions have all given very low or totally negligible position/speed error.

These results show that SMC has a high performance despite the presence of uncertainties on the parameters of the system and the existence of unknown disturbances. This control is adapted to control this type of system.

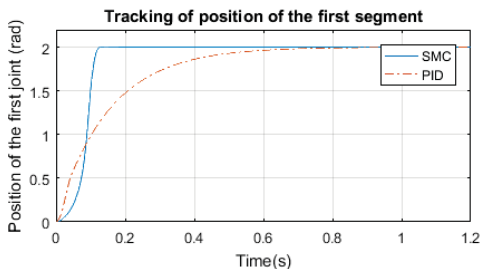

Fig. 3 Position tracking of the first joint

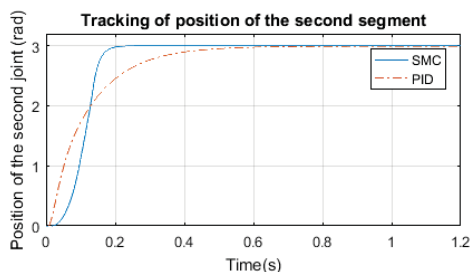

Fig. 4 Position tracking of the second joint

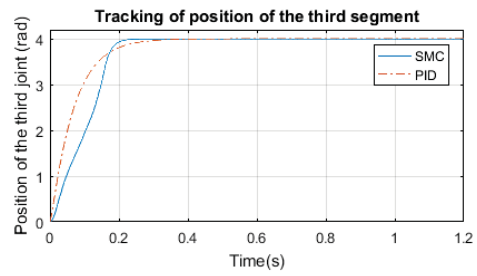

Fig. 5 Position tracking of the third joint

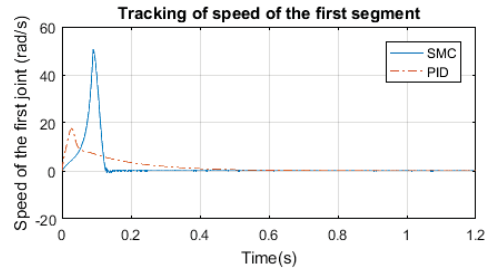

Fig. 6 Speed tracking of the first joint

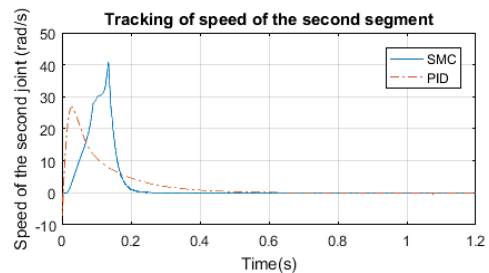

Fig. 7 Speed tracking of the second joint

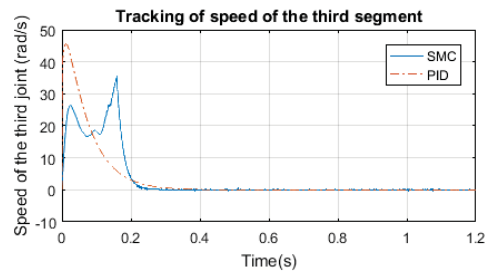

Fig. 8 Speed tracking of the third joint

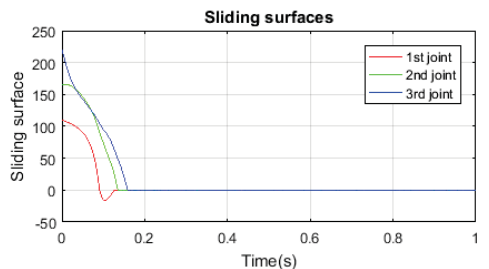

Fig. 9 Sliding surface

### III. TELEOPERATION SYSTEM DESIGN

The developed teleoperation system has the architecture in Fig. 11, It includes two sides, local side (client) and remote

side (server). The two sides are relied by Internet connection Fig. 11.

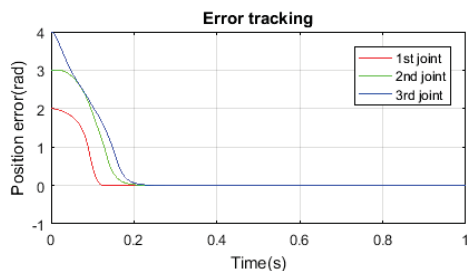

Fig. 10 Error tracking

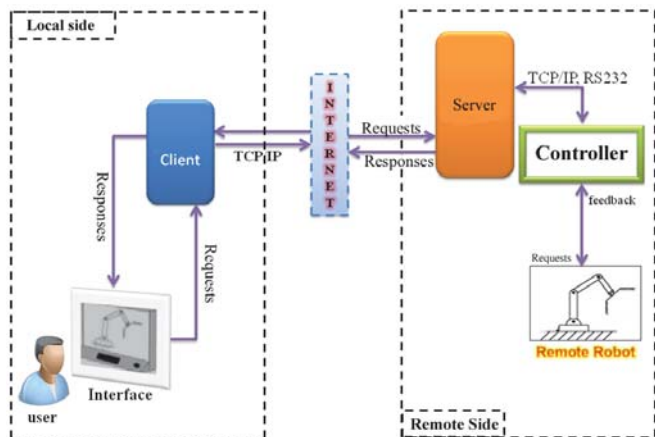

Fig. 11 Teleoperation system design

#### A. Local Side

In this side, a virtual 3D-model simulates the real robot. The operator can control the real robot by the sending of the wished positions in the user interface. Returns positions are used to provide the real positions of the remote robot. The operator must provide IP address and the port number of the server to ask for connection, once connection is established the operator can send the wished positions by slipping the sliders or by introducing the positions directly, after the execution of the task the operator receives the real positions of the remote robot in the interface (feedback). The client requirements can be sent to the server via Internet by using TCP/IP protocol, as well as received information.

#### B. Remote Side

In this side, after establishing the connection with the client, the server receives the wished positions, and sends them to the controller. The controller requests robot to do what the client asks. After that, the server sends the processed data (real positions) to the client via the Internet using the TCP/IP protocol. In order to realize the teleoperation system via the internet, the remote system is inserted into a control loop with the developed sliding mode controller. The remote system with the sliding mode controller is given by the figure as follows:

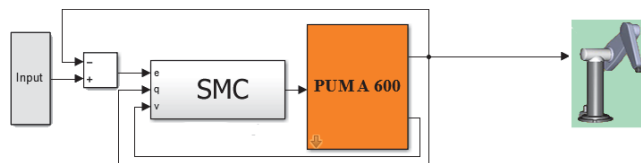

Fig. 12 Remote system

#### C. Simulation

In the remote site the server must be listened and wait for the connection request by the client, at this moment the robot is in the initial positions Fig.13.



Fig. 13 Initial state of teleoperation system

To run a task by the remote robot, it is necessary to launch the client interface, then enter the IP address of the server and specify the port number, and request the connection with the server, once the connection is successful, the operator can send the wished positions to the server. The server receives the wished positions and sends them to the robot controller, which run the requested task and sends the real positions to the server to send them to the client.

#### IV. RESULTS ANALYSIS

According to the results of the Fig. 14, it is clear that the wished positions received by the server are the same ones sent by the client.

The client receives the real positions sent by the server after execution of the requested task with high precision and with an limited transmission delay.

These results demonstrate the effectiveness of the developed teleoperation system, and the reliability of the Internet as a communication medium (*reliability and quality of service*).

The real positions (displayed on the client and server interfaces) indicates clearly the efficiency of the sliding mode control to achieve the best performance of the task requested by the client.

#### V. CONCLUSION

In this paper, a control approach based on the sliding mode has been implemented. We carried out simulations with this controller on the PUMA 600 manipulator robot. This controller has given high performance with fast dynamic response, and is very robust, insensitive to the variations of the parameters of the process and the external perturbations. Simulation results show that the designed controller is more robust and more efficient than the conventional PID controllers, viewing speed, accuracy and stability.

In order to remotely operate the PUMA 600 robot via the Internet, a complete teleoperation station has been developed

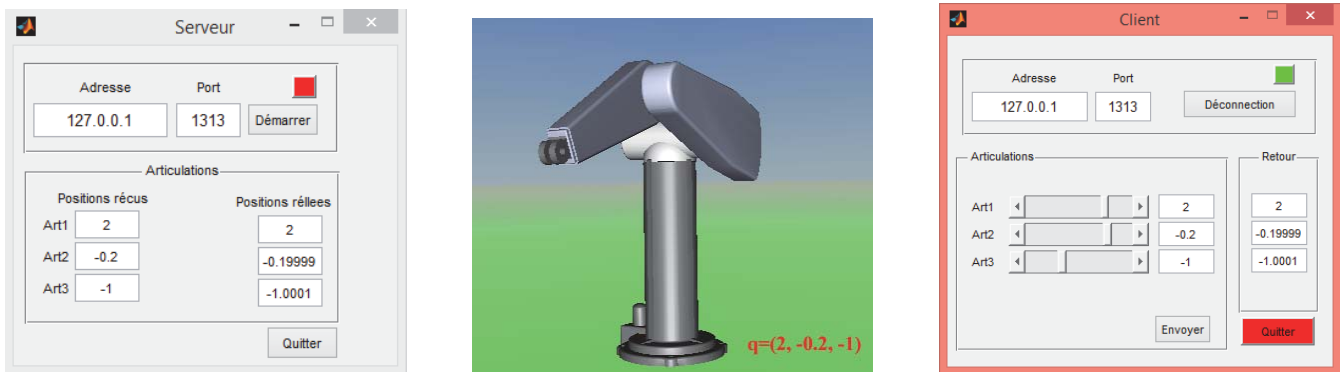

Fig. 14 Final positions of the robot

Fig. 11, based on Client/Server architecture, and contains an ergonomic and easy to use interfaces Figs. 13 and 14. The various tests carried out on this station, using the Internet as a means of communication, show the efficiency and the simplicity of the teleoperation of the manipulator arm PUMA 600. One of the main advantages offered by this station is its portability and its simplicity of installation on any machine. This advantage allows the PUMA 600 robot to be remotely operated from any machine connected to the Internet network. The use of virtual reality techniques offers to the operator a great opportunity to teleoperate the remote robot by controlling the virtual robot at the client interface. The sliding mode controller used to control the remote robot Fig. 12, provides a great improvement in performance on speed and accuracy, to perform the task requested by the operator.

#### ACKNOWLEDGMENT

The authors would like to thank Pr. kechich abderrahmane, Pr. Hazzab abdeldjebbar, Dr. Kadri boufeldja and Dr. Maamri Khaled for their help and support during the realization of this work.

#### REFERENCES

- [1] Frank L. Lewis and Darren M. Dawson and Chaouki T. Abdallah, Robot Manipulator Control: Theory and Practice, 2nd ed, M DEKKER, 2004.
- [2] Ignacio Herrera Aguilar, Commande des bras manipulateurs et retour visuel pour des applications robotique de service, PhD thesis, Paul Sabatier university, 1999.
- [3] Martin Pala and Daniel Lorencik and Peter Sincak, Towards the robotic teleoperation systems in education. 10th IEEE International Conference on Emerging eLearning Technologies and Applications, page 241 246, Novembre 2012.
- [4] Abdelghani Aissaoui, Hamza Abid, Mohamed Abid, and Ahmed Tahour, Commande par logique floue et mode glissant d'une machine synchrone autopilote. Revue roumaine des sciences techniques, 2009.
- [5] Jinkun Liu and Xinhua Wang. Advanced Sliding Mode Control for Mechanical Systems. Springer Heidelberg Dordrecht London New York, 2011.
- [6] Dawei Wang, Jianqiang Yi, Dongbin Zhao and Guosheng Yang, Teleoperation System of the Internet-based Omnidirectional Mobile Robot with A Mounted Manipulator, IEEE International Conference on Mechatronics and Automation August 5-8, 2007, Harbin, China.
- [7] Chun-yi Su and Yury Stepanenko, Adaptive Sliding Mode Control of Robot Manipulators: General Sliding Manifold Case, Automatica, Vol. 30, No. 9, pp. 1497-1500, 1994.
- [8] Jean-Jacques Slotine and Weiping Li, Applied Nonlinear Control, Prentice-Hall, 1991.
- [9] Vadim I. Utkin. Sliding Modes in Control and Optimization. Springer -Verlag, 1992.

- [10] M. Murray Richard, Zexiang Li, S. Shankar Sastry, and S. Shankara Sastry. A Mathematical Introduction to Robotic Manipulation. CRC Press, 1994.

**Ghoul Abdallah** was born in 1982 in Bechar City, Algeria. He received the B.Sc. degree in computer science from the Bechar university 2006, the M.Sc. degree in industrial computing and automatic from Bechar university in 2015, currently preparing his Ph.d degree in automatic and electrical engineering. His current research interest includes robotic, UAV, artificial intelligent control, teleoperation, telerobotic, and automation.

**Ouamri Bachir** was born in 1972 in Bejaa, Algeria. He received his BS degree from the Electrical Engineering Institute of the University of Bejaa in 1998, the MS degree from the University of Oran in 2004, and the Doctorat degree in 2014 from University of Sciences and Technology of Oran . He is currently Assistant Professor of Electrical and Computer Engineering at the University of Bechar (Algeria). His current research interest includes intelligent process control, teleoperation, telerobotic and automation.

**Bousserhane Ismail Khalil** was born in 1976 in Bechar, ALgeria. He received his BS degree in electrical engineering from the Electrical Engineering Institute of the University Center of Bechar, the M.S. degree in Electrical Engineering from the University of Sciences and Technology of Oran in 2003, Algeria. and the Doctorat degree in Electrical Engineering Institute of USTO in 2008. His area of interest are modern control techniques and their application in electric drives control.