

# Emulation of a Wind Turbine Using Induction Motor Driven by Field Oriented Control

L. Benaouinate, M. Khafallah, A. Martinez, A. Mesbahi, T. Bouragba

**Abstract**—This paper concerns with the modeling, simulation, and emulation of a wind turbine emulator for standalone wind energy conversion systems. By using emulation system, we aim to reproduce the dynamic behavior of the wind turbine torque on the generator shaft: it provides the testing facilities to optimize generator control strategies in a controlled environment, without reliance on natural resources. The aerodynamic, mechanical, electrical models have been detailed as well as the control of pitch angle using Fuzzy Logic for horizontal axis wind turbines. The wind turbine emulator consists mainly of an induction motor with AC power drive with torque control. The control of the induction motor and the mathematical models of the wind turbine are designed with MATLAB/Simulink environment. The simulation results confirm the effectiveness of the induction motor control system and the functionality of the wind turbine emulator for providing all necessary parameters of the wind turbine system such as wind speed, output torque, power coefficient and tip speed ratio. The findings are of direct practical relevance.

**Keywords**—Wind turbine, modeling, emulator, electrical generator, renewable energy, induction motor drive, field oriented control, real time control, wind turbine emulator, pitch angle control.

## I. INTRODUCTION

ELECTRICITY production using wind energy has become an important way to deal with the growing energy demands and environmental crisis as it is socially beneficial, environmentally friendly, and economically competitive for many applications. Therefore, a great deal of research has been converged on the development of the wind turbine technologies in order to increase the profits of the wind power and to make the wind turbine more economical and efficient.

In order to promote research on wind power technology, wind turbine emulators (WTEs) are designed to simulate the steady-state and dynamic behavior of the system in a controlled environment without reliance on natural wind resources and real wind turbines. WTEs can produce a mechanical torque which depends on the wind speed and the possible presence of a device for orienting the blades. Also, they can be used for education purpose to teach on the wind turbine (operating, control...).

The aim of this paper is to present the development of a useful WTE based on induction motor (IM) controlled by Field Oriented Control (FOC) to obtain the characteristics and

the performances for applying wind power conversion researches.

There are several approaches for emulator used in different situations depending on the desired requirements such as the power range and the type of wind turbine. The most common type of motor used in the construction of WTE is DC motor because of the easy implementation and the direct relationship between armature current and the torque produced by the machine as presented in references [2], [3], [5], [7], [9], [10]. However, it is expensive compare to an AC machine, it needs frequent maintenance due to its commutators and brushes and it is bulky. WTE based on an IM has smaller size relative to DC motor for given power range.

The Fuzzy Logic Controller (FLC) is used in this work as an alternative to the proportional-Integral (PI) controller in wind turbine pitch angle control. It is chosen for their stability, fast dynamic response, solving non-linear systems such as the wind which has the nonlinearity as its main characteristic.

## II. DYNAMIC MODELS FOR WIND POWER SYSTEM

A wind power system can be described using three mathematical models: aerodynamic, mechanical, and electrical model [13]. Fig. 1 shows the basic structure of the wind power system.

### A. Aerodynamic Model

#### 1) Aerodynamic Power

The mechanical power extracted by the wind turbine is expressed as:

$$P_w = \frac{1}{2} \pi \rho R^2 V_t^3 C_p(\lambda, \beta) \quad (1)$$

where  $R$  is the turbine rotor radius in meters (m),  $\rho$  is the air density ( $\text{kg/m}^3$ ),  $R$  is the turbine radius (m),  $V_t$  is the wind speed in (m/s) and  $C_p$  is the power coefficient, it is a function of both blade pitch angle  $\beta$  and Tip Speed Ratio (TSR)  $\lambda$ , it represents the ratio of maximum power obtained from the wind to the total power available in the wind.

The tip speed ratio  $\lambda$  is expressed as:

$$\lambda = \frac{\omega R}{V_t} \quad (2)$$

where  $\omega$  is the angular speed of the turbine rotor in (rad/s).

L. Benaouinate, M. Khafallah, and A. Mesbahi are with Laboratory of Energy & Electrical Systems (LESE), Hassan II University of Casablanca ENSEM, Morocco (e-mail: l.benaouinate@ieec.org, mohamed.khafallah@uh2c.com, abdelouahed.mesbahi@gmail.com).

A. Martinez, and D.Breuil, are with Laboratoire Energie Renouvelable Propre & Alternative (LERPA), EIGSI la rochelle, France (e-mail: andre.martinez@eigsi.fr, dominique.breuil@eigsi.fr).

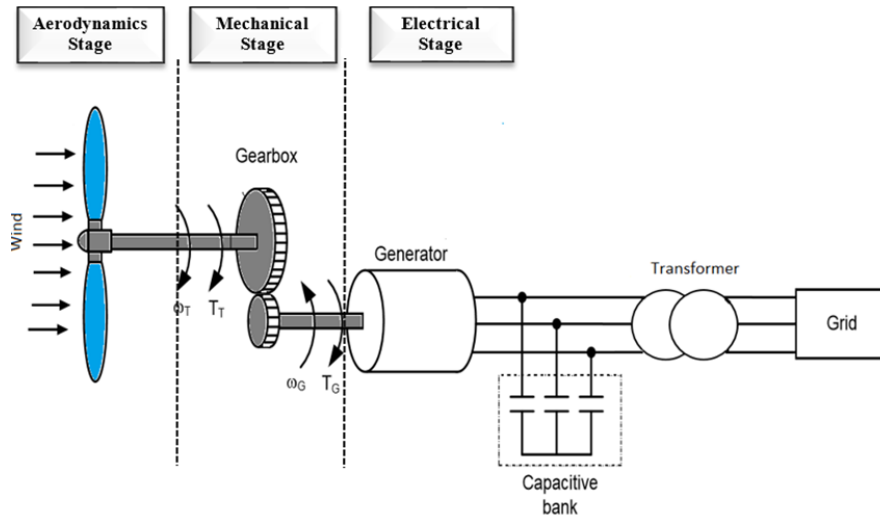

Fig. 1 Wind Power System

The curve power that relates  $C_p$  to the different value of pitch angle  $\beta$  and TSR  $\lambda$  is different for each wind turbine and it is obtained from direct measurements of the turbine in operation. The generic equation used to model the  $C_p$  is obtained from the curve power for different points of operation of the turbine. An expression that is commonly used for the determination of  $C_p$  is:

$$C_p(\lambda, \beta) = C_1(C_2\lambda_i - C_3\beta - C_4)e^{C_5\lambda_i} + C_6\lambda \quad (3)$$

$$\lambda_i = \frac{1}{\lambda + 0.08\beta} - \frac{0.0035}{\beta^3 + 1} \quad (4)$$

Table I shows the parameters of the performance coefficient.

TABLE I  
PARAMETERS OF THE PERFORMANCE COEFFICIENT

C1	C2	C3	C4	C5	C6
0.5109	116	0.4	5	21	0.0068

The torque of a wind turbine is expressed as:

$$T_w = \frac{1}{2} \frac{\pi \rho R^3 V_t^2 C_p(\lambda, \beta)}{\lambda} \quad (5)$$

According to (5), the mechanical torque of the wind turbine is relative to the wind speed. Therefore, it is expected to produce a torque with a stochastic profile.

## 2) Blade Aerodynamics

Blade Element Momentum (BEM) method can be used to examine how a wind turbine works and to predict the blade forces produced due to the interaction of the blade and the wind. When the wind passes through the rotor plane and interacts with the moving rotor, a resultant relative velocity at the blade is introduced, depicted as  $W$  in Fig. 3, which is the difference between the undisturbed wind velocity and the

blade tip velocity.

$$W = \sqrt{V_t^2(1-a^2) + \Omega^2 r^2(1+a')^2} \quad (6)$$

where  $V_t$  is the wind velocity perpendicular to the rotor plane,  $r$  is the distance of blade element from the rotor axis,  $a$  and  $a'$  are the flow factors and  $\Omega$  is the angular velocity of blades. The aerodynamics forces on the blade are the lift force and the drag.

The lift force is:

$$\vec{L} = \frac{1}{2} \rho c W^2 C_L \quad (7)$$

The drag force is:

$$\vec{D} = \frac{1}{2} \rho c W^2 C_D \quad (8)$$

where  $C_L$  and  $C_D$  are respectively the lift and drag coefficient,  $c$  is the chord length of the blade, and  $\rho$  is the air density.

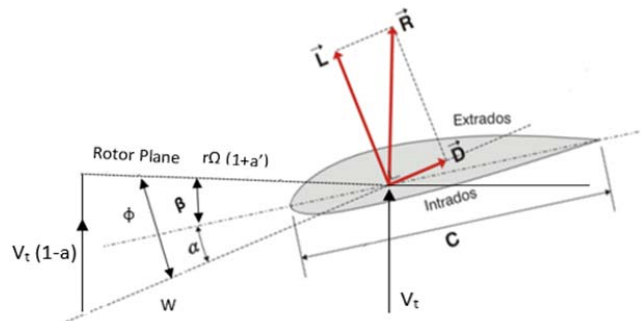

Fig. 2 Profile of a turbine blade

The resultant relative velocity at the blade  $W$  creates an angle with the blade chord  $C$ , depicted as  $\alpha$  in Fig. 3, the angle

of attack. It is controlled by rotating the blade about its axis. The pitch angle  $\beta$  is the angle formed by the blade chord  $C$  and the rotor plane. The power of the wind turbines depends on the wind velocity, it increases as the wind increases. Therefore, the wind turbine must be protected against the risk of damages from the strong wind. This can be achieved by rotating the blade about its axis in a position where a part of incoming wind will pass by the wind turbine. The angle of attack  $\alpha$  decreases when the pitch angle  $\beta$  increases. The lift force  $\bar{L}$  decreases as well and this reduces the wind turbine's mechanical power.

### B. Coupling System and Transmission

The mechanical model of a wind turbine is commonly modeled by two rotating masses. This model is basically involved the rotor of the wind turbine and the generator shaft. The association between them can be made with a gearbox or direct coupling. Fig. 3 shows the structure of the mechanical model.

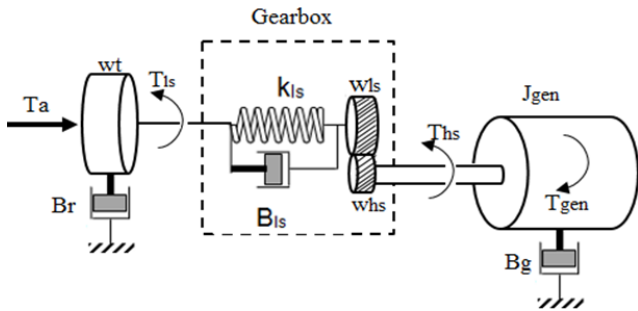

Fig. 3 Mechanical model of wind turbine

The parameters presented in Fig. 2 are described:  $T_a$ : Torque of the turbine applied on the rotor;  $T_{ls}$ : Torque applied on low speed shaft;  $T_{hs}$ : Torque applied on high speed shaft;  $T_{gen}$ : electromagnetic torque of generator;  $W_t$ : rotor angular speed;  $W_{ls}$ : angular speed of the low speed shaft;  $W_{hs}$ : angular speed of the high speed shaft;  $B_r$ : rotor damping effect;  $B_{ls}$ : low speed damping effect;  $B_g$ : high speed damping effect;  $K_{ls}$ : Stiffness of low speed shaft;  $J_g$ : moment of inertia of the generator;  $n_g$ : speed multiplication ratio.

Thus, the equations for the mechanical model of the wind turbine are:

$$T_a - T_{ls} = J_r \dot{w}_t + B_r w_t \quad (9)$$

$$T_{ls} = B_{ls} (w_t - w_{ls}) + K_{ls} (\theta_t - \theta_{ls}) \quad (10)$$

$$T_{hs} - T_{gen} = J_g \dot{w}_{hs} + B_g w_{hs} \quad (11)$$

$$n_g = \frac{T_{ls}}{T_{hs}} \quad (12)$$

### C. Electrical Model

The electrical dynamic equations of permanent magnet

synchronous generator (PMSG) are expressed as [6], [8]:

$$V_d = R_s i_d - w_e L_q i_q + L_d \frac{di_d}{dt} \quad (13)$$

$$V_q = R_s i_q - w_e (L_d i_d + \psi_f) + L_q \frac{di_q}{dt} \quad (14)$$

$$\frac{di_d}{dt} = \frac{1}{L_{ds} + L_{ls}} (-R_s i_d + w_e (L_{qs} + L_{ls}) i_q + V_d) \quad (15)$$

$$\frac{di_q}{dt} = \frac{1}{L_{qs} + L_{ls}} (-R_s i_q - w_e [(L_{ds} + L_{ls}) i_d + \psi_f] + V_q) \quad (16)$$

where  $p$  is the number of pole pairs,  $\omega_e$  is the angular speed of the reference frame ( $\omega_e = p\omega_g$ ),  $\psi_f$  is the flux constant of the generator rotor,  $L_d$  and  $L_q$  are the inductance of the stator in the Park reference frame, and  $R_s$  is the stator resistance.

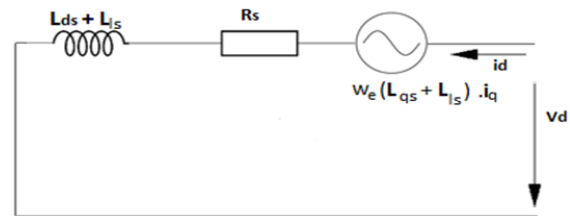

Fig. 4 D-axis equivalent circuit

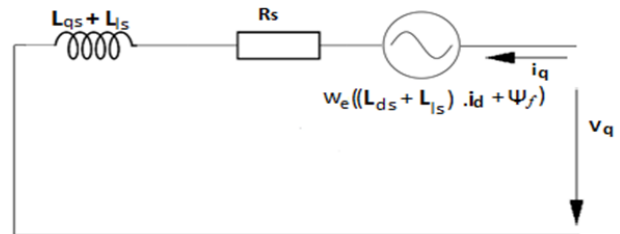

Fig. 5 q-axis equivalent circuit

Figs. 4 and 5 show the equivalent circuit of the PMSG in d-q synchronous rotating reference frame.

The electrical torque ( $T_g$ ) of the generator is expressed as:

$$T_g = \frac{3}{2} (\psi_p m i_q + (L_d - L_q) i_d i_q) \quad (17)$$

### III. WTE DESIGN

Fig. 6 represents the structure of the WTE using IM controlled by torque control inverter.

The wind speed, the pitch angle, and the mechanical torque of IM are the three inputs of a mathematical model of the wind turbine, and its output is a speed depending practically on the wind velocity.

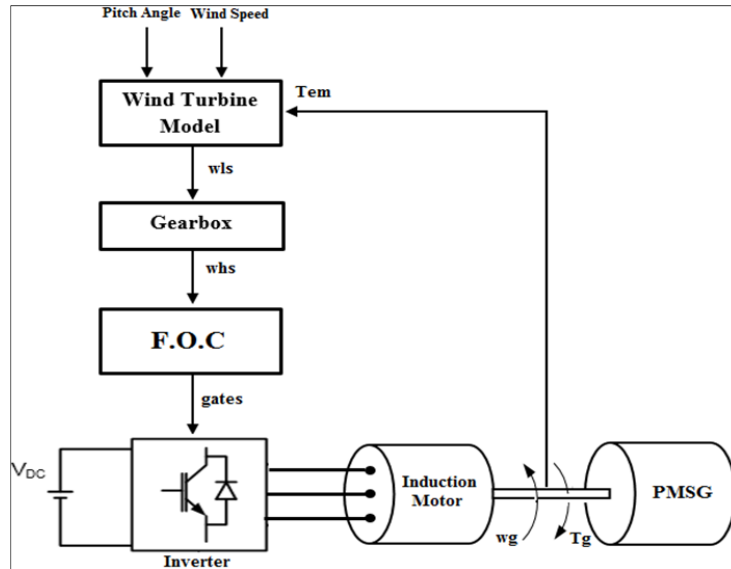

Fig. 6 Structure of WTE

In order to emulate the real behavior of the wind turbine, it is necessary to compare the speed characteristics of the mathematical model of the wind turbine and the IM. The reference speed derived from the mathematical model is the input of a speed controller based on a PI regulator, and the outputs of this regulator are set points for the torque and the flux applied to the FOC block. This control consists of controlling the stator currents of the IM by generating pulses to the inverter, and producing a mechanical torque depends on the wind velocity required by the PMSG in a similar way as the real wind turbine.

#### A. IM Model in the Park Reference Frame

For torque and rotor flux calculation, stator current in three-phase system (a, b, c) is decomposed in two dimensions orthogonal system. This change of variables is well known as Park transformation and can be used to reduce the complexity of the system control implementation. After the acquisition, the stator abc voltage and current are transformed into a stationary dq coordinate system.

The dq stator voltages are expressed as:

$$V_{sd} = R_s I_{sd} + \frac{d\psi_{sd}}{dt} - \omega_s \psi_{sq} \quad (18)$$

$$V_{sq} = R_s I_{sq} + \frac{d\psi_{sq}}{dt} + \omega_s \psi_{sd} \quad (19)$$

The dq rotor voltages are expressed as:

$$0 = R_r I_{rd} + \frac{d\psi_{rd}}{dt} - \omega_r \psi_{rq} \quad (20)$$

$$0 = R_r I_{rq} + \frac{d\psi_{rq}}{dt} + \omega_r \psi_{rd} \quad (21)$$

The dq stator flux is expressed as:

$$\psi_{sd} = L_s I_{sd} + M_{SR} I_{rd} \quad (22)$$

$$\psi_{sq} = L_s I_{sq} + M_{SR} I_{rq} \quad (23)$$

The dq rotor flux is expressed as:

$$\psi_{rd} = L_r I_{rd} + M_{SR} I_{sd} \quad (24)$$

$$\psi_{rq} = L_r I_{rq} + M_{SR} I_{sq} \quad (25)$$

The torque is expressed as:

$$T_e = p \frac{M_{Rq}}{L_r} (\psi_{rd} I_{sq} - \psi_{rq} I_{sd}) \quad (26)$$

The speed is expressed as:

$$\omega_s = p\Omega + \omega_r \quad (27)$$

#### B. Torque and Flux Control

The Field Orientated Control (FOC) is a technique of controlling the stator currents identified as two orthogonal components that can be represented by a vector. This control for the IM is based on Park reference which corresponds to a two-phase reference frame and it is generally related to the rotating magnetic field. This projection leads having for the IM a mechanical torque proportional to a flux and current similar to that of DC machine.

The flux component (aligned with d coordinate) and the torque component (aligned with q coordinate) are the two constant reference inputs of the FOC strategy.

The use of an IM with FOC brings more accurate to the

torque with less ripples but depends on machine parameter. This control requires a high performance calculator and

consumes more processing resources. Fig. 7 represents the structure of FOC.

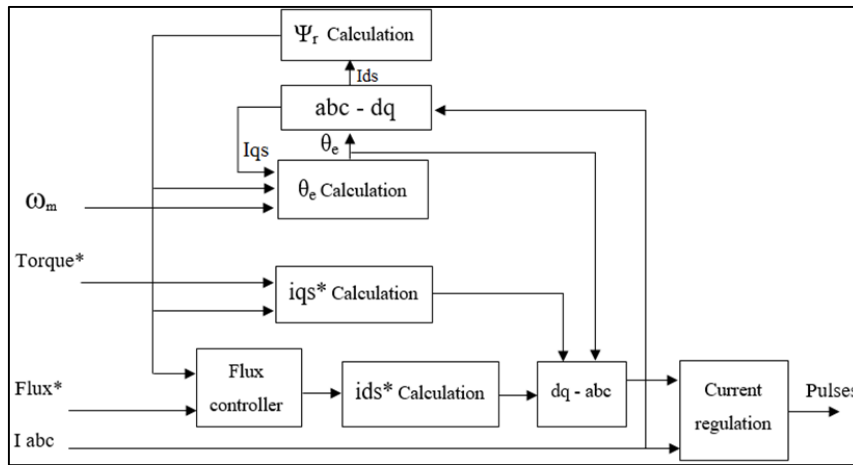

Fig. 7 Structure of FOC

According to the motor equation synthesis, the motor's rotor flux  $\psi_r$  is estimated to find the phase angle of the rotor flux rotating field  $\theta_e$  and calculating with the torque reference  $Torque^*$  the stator current quadrature component needed to develop the electromagnetic torque on the motor's shaft.

The rotor flux reference  $Flux^*$  is used to compute the stator current direct component required to produce the rotor flux in the machine.

In order to reduce the steady-state flux error and controlling the flux dynamics a flux controller based on PI regulator is used.

The bang-bang current controller with adjustable hysteresis band width is used as the current regulator.

The equations for the structure of FOC are as follows:

$$i_{qs}^* = \frac{T_E}{p} \frac{L_R}{\psi_r M_{SR}} \quad (28)$$

$$i_{ds}^* = \frac{\psi_r}{M_{SR}} \quad (29)$$

$$\theta_e = \int \omega_r + \omega_m \quad (30)$$

$$\omega_r = \frac{M_{SR} R_R}{\psi_r L_R} I_{qs} \quad (31)$$

$$\psi_r = \frac{M_{SR}}{1 + t_{RS}} I_{ds} \quad (32)$$

### C. Pitch Angle

#### 1) Pitch Actuator

The wind turbine operates mainly in four regions delimited

by the critical operating points. The first region related to low wind speeds. In this region, the wind turbine encounters the first critical point known as cut-in speed. Below this speed, the wind turbine does not operate, and it does not produce power as well; once this point reached, the wind turbine begins to capture the maximum energy from wind speed as power is proportional to wind speed. As the wind speed increases, the second critical point that is reached by the wind turbine is the rated speed. This region is related to medium and high wind speeds. Once the wind speed exceeds this point, the wind turbine blades begin to adjust their pitch angle to minimize the extracting of energy by shedding some of the energy in the wind. The objective of the control is to regulate both output power and speed to their rated values. As the wind speed increases, the third critical point that is reached is the cut-out speed. At this point, the wind turbine reaches their mechanical limit, it must shut-down to prevent damage to its self [1], [12], [14].

These regions of operation are shown in Fig. 8 where  $\theta$  represents the blade pitch angle.

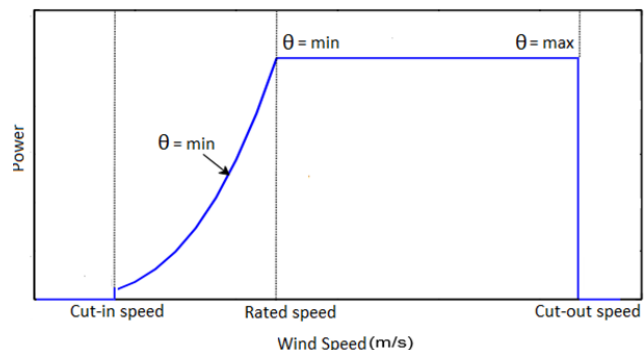

Fig. 8 Regions of wind turbine operation

The best way to exploit the maximum capacity of the wind in wind energy conversion systems is through the variable

speed wind turbines with pitch angle control [4], [11], [14]. However previous studies into the emulation of wind turbine system do not give attention to the control of pitch angle system. In order to make the WTE system more efficient and able to provide a complete substitution of the real wind turbine, we presented the pitch control using a FLC for their usefulness when the system is nonlinear, such as the wind.

### 2) Pitch Angle Control Using Fuzzy Logic

Fig. 9 shows the pitch angle control block diagram using fuzzy control.

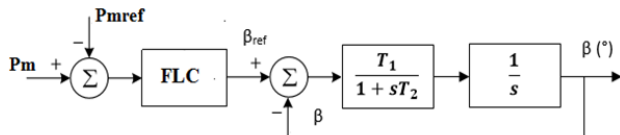

Fig. 9 Pitch angle block diagram using FLC

The present work developed the fuzzy control using the Fuzzy Logic Toolbox™ of MATLAB/Simulink. Figs. 10 and 11 represent respectively Membership function plots of input and output of the FLC using Mamdani's fuzzy inference method to define how each point in the universe of discourse is mapped to a degree of membership between 0 and 1.

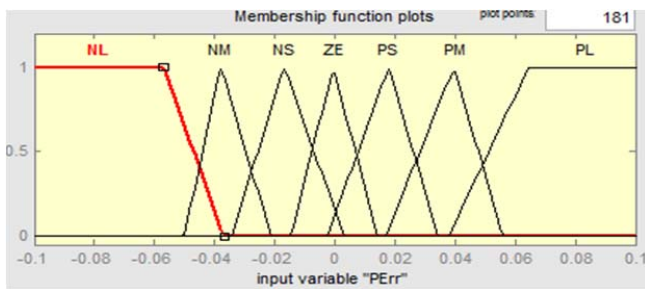

Fig. 10 Membership function ΔP

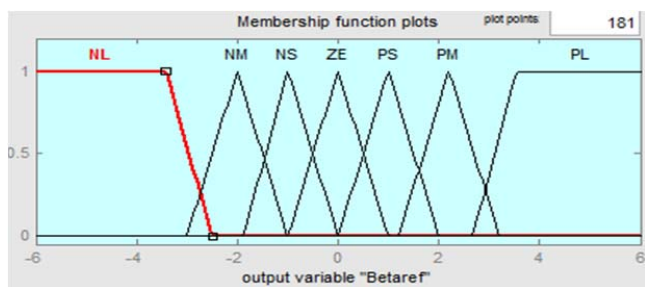

Fig. 11 Membership function Output

Table II gives the rule base modeled in this work for the FLC.

TABLE II  
 RULES BASE FOR FLC

ΔP	NL	NM	NS	ZE	PS	PM	PL
β <sub>ref</sub>	NL	NM	NS	ZE	PS	PM	PL

The abbreviations used in Table II are defined as follows:

- NL is negative large;

- NM is negative medium;
- NS is negative small;
- ZE is Zero;
- PL is positive large;
- PM is positive medium;
- PL is positive large.

The De-Fuzzification is the process of interpreting the membership degrees of the fuzzy sets into a real value. In this FLC, the centroid method from singletons functions is used.

### IV. SIMULATION RESULTS AND DISCUSSIONS

Based on the different mathematical models of wind power system presented previously, a software application was developed in MATLAB/Simulink. Fig. 12 presents the block diagram of the implemented and simulated WTE system. The wind profile exploited in this simulation is presented in Fig. 13 and it is modeled in the deterministic form of a sum of several harmonics:

$$V_i(t) = 9 + 0.2\sin 1.047t + 2\sin 2.665t + \sin 1.293t + 0.2\sin 36.645t \quad (33)$$

TABLE III  
 PARAMETERS OF THE IM AND PMSG

EQUIPMENT	PARAMETERS
IM	- Rated power: 1.5 kW;
	- Rated speed: 1450 rpm;
	- Number of pole pairs: 2;
	- Moment of inertia: $9.7 \cdot 10^{-3} \text{ kg}\cdot\text{m}^2$ ;
	- Stator resistance ( $R_s$ ): $5.63 \Omega$ ;
	- Rotor resistance ( $R_r$ ): $2.89 \Omega$ ;
	- Stator inductance ( $L_s$ ): $0.385 \text{ H}$ ;
	- Stator inductance ( $L_r$ ): $0.385 \text{ H}$ ;
	- Mutual inductance ( $L_m$ ): $0.367 \text{ H}$ ;
	- Viscous friction $f$ : $1.55 \cdot 10^{-3} \text{ Nm/rd/s}$ .
PMSG	- Type MA-6;
	- Stall Torque: $3.6 \text{ Nm}$
	- Rated armature voltage: $127 \text{ V}$
	- Stall current: $4.2 \text{ A}$
	- Max Mechanical speed: $6000 \text{ rpm}$
	- Winding Resistor: $5.3 \Omega$
	- Winding Inductance: $11.6 \text{ mH}$
- Rotor Inertia: $0.3 \text{ Kg m}^2 \cdot 10^{-3}$	
- Torque Constant: $0.9 \text{ Nm/A}$	

Fig. 14 shows the dynamic behavior of the rotor speed of IM. The IM's speed mostly depends on the wind speed velocities. This means that WTE can provide a speed similar to the wind turbine speed.

Fig. 15 shows the torque generated by the IM, it pursues the different variation of wind speed, which confirms the effectiveness of WTE by reproducing the torque developed by a wind turbine for given wind velocities and driving the electrical generator in a similar way as a wind turbine.

Fig. 17 shows the different values of pitch angle  $\beta$  for different wind velocities. Adjusting the pitch angle of the blades, provides an effective means of regulations or limiting turbine performance in strong wind speeds. The pitch angle  $\beta$  increases when the wind speed increases, which decreases the angle of attack. The lift force diminishes also, and this causes decrease of mechanical energy of WTE.

Fig. 18 shows the line current generated by the PMSG. Both

the amplitude and frequency of the PMSG current varies depending on the wind profile.  
 As it can be analyzed from the figures, there is a high level of correspondence between the wind speed profile applied to

the mathematical wind turbine model and the characteristics of different responses of WTE such as the torque, the speed and pitch angle.

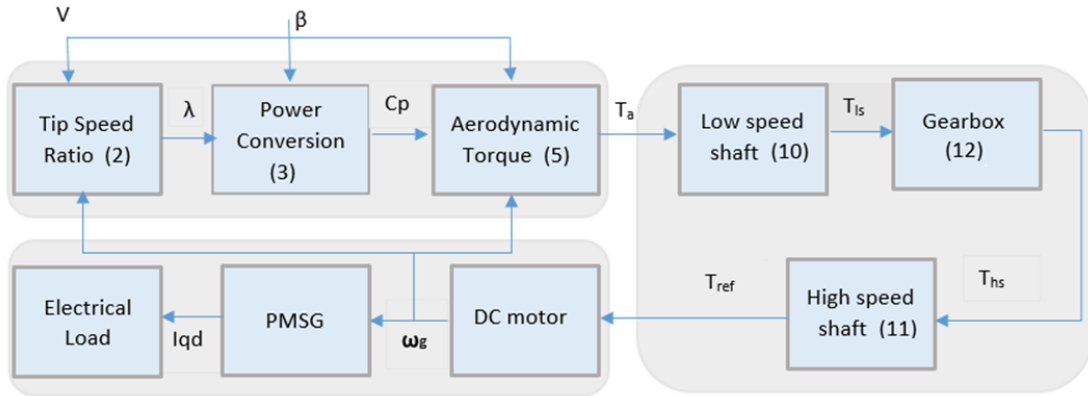

Fig. 12 Membership function output

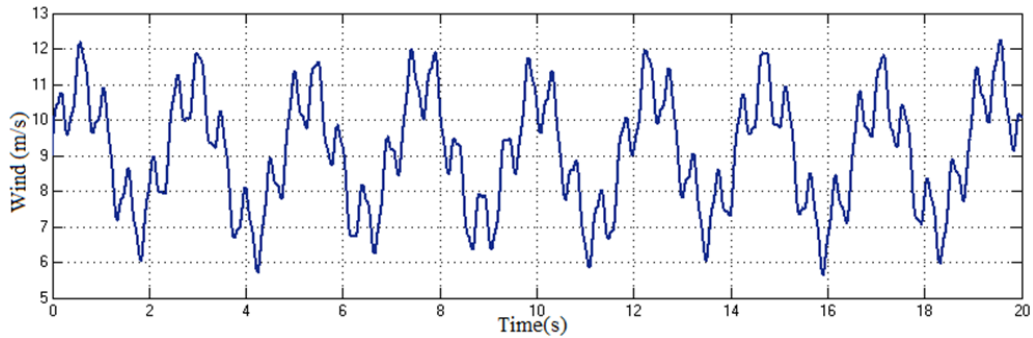

Fig. 13 Wind profile

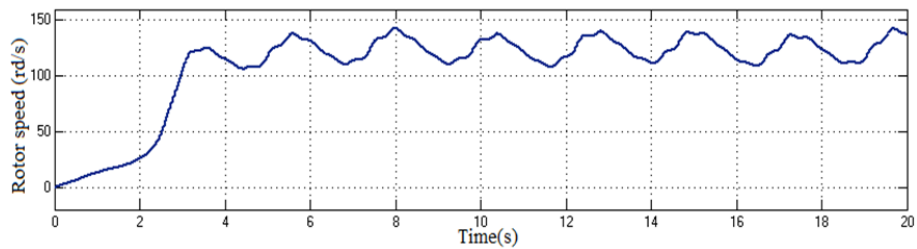

Fig. 14 Rotor speed of IM

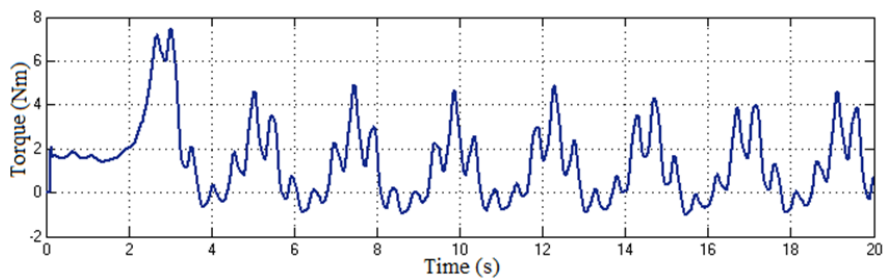

Fig. 15 Mechanical torque of IM

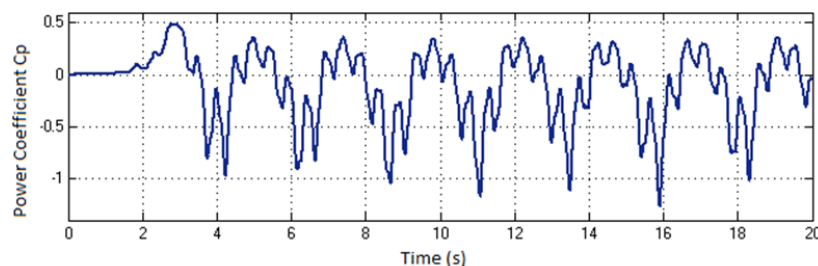

Fig. 16 Power coefficient of the wind turbine

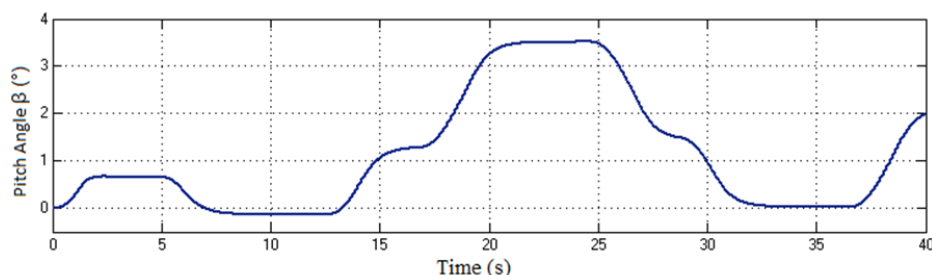

Fig. 17 Pitch angle

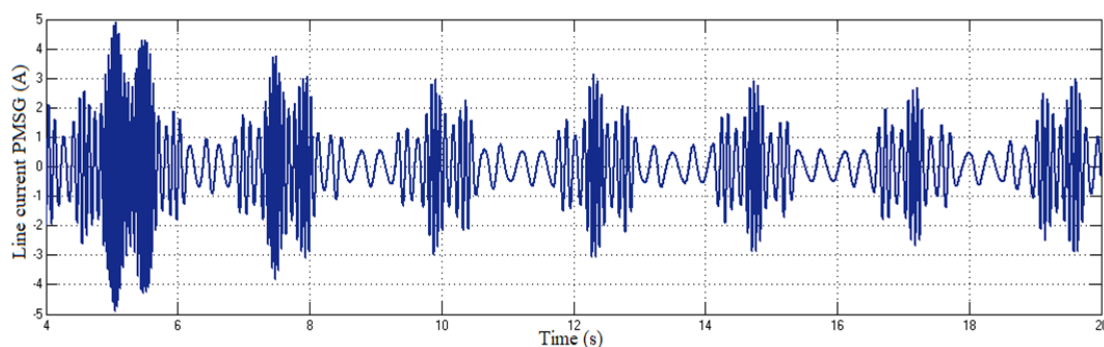

Fig. 18 PMSG current line response

From results, it can be confirmed that the WTE can efficiently provide the steady-state and dynamic characteristics of a given wind turbine for different wind conditions.

#### V. CONCLUSION

Our work describes the main components of a WTE based on IM controlled by FOC.

WTE can supply all required parameters of the wind turbine system such power coefficient, tip speed ratio, output torque and output power. It creates a controlled test environment for research into WECS.

The control of pitch angle is one of the main steps in the emulation of the wind turbine for providing more realistic conditions for the emulator and a complete substitution of the real wind turbine. However, most of the previous studies into the WTE systems do not take into account the control of pitch angle despite the best way to extract the maximum power of the wind is through the variable speed wind turbines with pitch angle control.

FLC is used in the pitch angle control system for their high

accuracy, fast dynamic response, stability, solving nonlinear systems such as the wind which has the nonlinearity as its main characteristic.

The next stage of our research will be the experimental confirmation of our theory.

#### REFERENCES

- [1] A. V. A. Macêdo, W. S. Mota, and S. Member, "Wind Turbine Pitch Angle Control Using Fuzzy Logic," pp. 1–6, 2012.
- [2] H. M. Kojabadi and L. Chang, "Wind Turbine Simulators," Wind Turbines, pp. 163–174, 2011.
- [3] M. Arifujjaman, « Emulation of a small wind turbine system with a separately-excited Dc machine », IU-Journal of Electrical & Electronics Engineering, vol. 8, no. 1, 2012.
- [4] S. Kumsup, C. Tarantisuk, « Real-time wind turbine emulator for testing wind energy conversion systems », in IEEE International Energy Conference and Exhibition, 2010, p. 7–9.
- [5] W. Li, D. Xu, W. Zhang, H. Ma, « Research on wind turbine emulation based on DC motor », in 2nd IEEE Conference Industrial Electronics and Applications, 2007, p. 2589–2593.
- [6] H. Wu, M. Ding, « Modeling and control of distribution system with wind turbine generators », in Third International Conference Electric Utility Deregulation and Restructuring and Power Technologies, 2008, p. 2498–2503.
- [7] L. Guangchen, W. Shengtie, Z. Jike, « Design and Realization of DC Motor and Drives Based Simulator for Small Wind Turbine », in Asia-



- Pacific Power and Energy Engineering Conference ,2010, p. 1–4.
- [8] V. Akhmatov, Variable-speed Wind Turbines with Doubly-fed Induction Generators – Part I: Modelling in Dynamic Simulation Tools. *Wind Engineering*, [S.l.], vol. 26, no. 2, p. 85-108, 2002.
- [9] S. Kouadria, S. Belfedhal and Y. Meslem, “Development of Real Time Wind Turbine Emulator Based on DC Motor Controlled by Hysteresis Regulator”, *IEEE International Renewable and Sustainable Energy Conference (IRSEC'13)*, 7-9 March 2013, pp. 246-250, Ouarzazate.
- [10] K. Han and G. zhu Chen, “A novel control strategy of wind turbine MPPT implementation for direct-drive PMSG wind generation imitation platform,” *IEEE 6th International Power Electronics and Motion Control Conference*, 2009, pp. 2255–2259, 2009.
- [11] J.M. Nye, J.G. Bat, M.A. Khan and P. Barendse, “Design and Implementation of a Variable Speed Wind Turbine Emulator”, *IEEE 20th International Conference on Electrical Machines (ICEM'12)*, 2-5 September 2012, pp. 2060-2065, Marseille.
- [12] Hardy, T., & Jewell, “Emulation of a 1.5 mw wind turbine with a dc motor” *Power and energy society general meeting*, 2011 ieeec (pp. 1–8).
- [13] Martinello, D., Carati, E. G., da Costa, J. P., Cardoso, R., & Stein, C. M., “Emulation of wind turbines” *Wind turbines-design, control and applications*, InTech 2016.
- [14] L. Benaouinate, M. Khafallah, A. Mesbahi, A. Martinez, and T. Bouragba, “Emulation of a Wind Turbine with a DC Motor controlled by Fuzzy Logic controller,” vol. 20, no. 2, pp. 97–101, 2017.