

Voyage Analysis of a Marine Gas Turbine Engine Installed to Power and Propel an Ocean-Going Cruise Ship

Mathias U. Bonet, Pericles Pilidis, Georgios Doulgeris

Abstract—A gas turbine-powered cruise Liner is scheduled to transport pilgrim passengers from Lagos-Nigeria to the Islamic port city of Jeddah in Saudi Arabia. Since the gas turbine is an air breathing machine, changes in the density and/or mass flow at the compressor inlet due to an encounter with variations in weather conditions induce negative effects on the performance of the power plant during the voyage. In practice, all deviations from the reference atmospheric conditions of 15 °C and 1.103 bar tend to affect the power output and other thermodynamic parameters of the gas turbine cycle. Therefore, this paper seeks to evaluate how a simple cycle marine gas turbine power plant would react under a variety of scenarios that may be encountered during a voyage as the ship sails across the Atlantic Ocean and the Mediterranean Sea before arriving at its designated port of discharge. It is also an assessment that focuses on the effect of varying aerodynamic and hydrodynamic conditions which deteriorate the efficient operation of the propulsion system due to an increase in resistance that results from some projected levels of the ship hull fouling. The investigated passenger ship is designed to run at a service speed of 22 knots and cover a distance of 5787 nautical miles. The performance evaluation consists of three separate voyages that cover a variety of weather conditions in winter, spring and summer seasons. Real-time daily temperatures and the sea states for the selected transit route were obtained and used to simulate the voyage under the aforementioned operating conditions. Changes in engine firing temperature, power output as well as the total fuel consumed per voyage including other performance variables were separately predicted under both calm and adverse weather conditions. The collated data were obtained online from the UK Meteorological Office as well as the UK Hydrographic Office websites, while adopting the Beaufort scale for determining the magnitude of sea waves resulting from rough weather situations. The simulation of the gas turbine performance and voyage analysis was effected through the use of an integrated Cranfield-University-developed computer code known as ‘Turbomatch’ and ‘Poseidon’. It is a project that is aimed at developing a method for predicting the off design behavior of the marine gas turbine when installed and operated as the main prime mover for both propulsion and powering of all other auxiliary services onboard a passenger cruise liner. Furthermore, it is a techno-economic and environmental assessment that seeks to enable the forecast of the marine gas turbine part and full load performance as it relates to the fuel requirement for a complete voyage.

M. U. Bonet was at the Cranfield University but is now with the Department of Mechanical Engineering, Nigerian Defence Academy, P. M. B. 2109; Kaduna, Nigeria (e-mail: mubonet@nda.edu.ng).

P. Pilidis is the Head, Power and Propulsion Department, Cranfield University, MK43 0AL, Bedfordshire, United Kingdom (e-mail: p.pilidis@cranfield.ac.uk).

G. Doulgeris was with the Power and Propulsion Department, Cranfield University, MK43 0AL, Bedfordshire, United Kingdom (e-mail: georgedoulgeris@gmail.com).

Keywords—Cruise ship, gas turbine, hull fouling, performance, propulsion, weather.

I. INTRODUCTION

SUMMER temperatures in the Middle East and North Africa frequently exceed 40 °C, while some areas around the world experience large seasonal temperature swings of over 38 °C. Ambient temperature, humidity and altitude, a function of geographical location and season, can grossly affect the density of the compressor inlet air being inducted into the gas turbine engine since it is an air-breathing machine. The above mentioned parameters therefore are capable of negatively impacting on the gas turbine power output and performance when they fall short of their optimal design values [1]. There exist some technical and economic considerations for the selection of the gas turbine alternative, as a ship propulsion prime mover considers the negative impact of any increase in site elevation on the engine overall caused by reductions in compressor inlet air density. In practice, the installation of air filters and evaporative coolers at the compressor inlet as well as silencers or heat recovery devices at its outlet result in additional pressure losses within the system. It is then worthy to note that the gas turbine initial cost as well as its operating cost along with its reliability and how environmentally friendly are some of the technical and economic variables considered in the selection of the gas turbine alternative as a ship propulsion prime mover. Hence, experience from the first gas turbine-powered cruise ships which are still in service reveal some of these attributes of the gas turbine when used as a propulsion alternative over the preferred conventional diesel-mechanical and diesel-electric systems as compared in Table I.

In the case of a Passenger ship, the extreme high power density and the very high operating speeds of the gas turbine result in a nearly vibration-free machinery plant which gives rise to a potentially quieter and smoother voyage for both passengers and crew, while its compactness can easily be exploited for creating extra accommodation or public spaces. When compared to a diesel-electric option, notwithstanding the arrangement philosophy in a large cruise ship project, some 20–100 more cabins can be incorporated within the same hull dimensions [2]. However, this major attribute and the weight advantage of being lighter than the diesel alternative may be lost to the associated increase in fuel storage facility [3]. Being the model under investigation, the thermodynamic cycle of a typical simple cycle gas turbine is currently capable of converting 30% to 40% of the fuel input into shaft power

output, while the rest may remain in the form of exhaust heat.

For high utilization of the fuel input to the gas turbine, the combined cycle, which is generally defined as one or more gas turbines equipped with heat-recovery steam generators in the exhaust, is installed to produce steam for the generation of additional power in a steam turbine. It may also be for the facilitation of a heat-to-process plant or a combination of both. High utilization of the fuel input can also be achieved through the configuration of more complex heat-recovery cycles that may involve multiple-pressure boilers and extraction or topping steam turbines. A combined cycle as illustrated in Fig. 1 fall into the 50% to 60% thermal efficiency, while it may be possible to attain more than 80% utilization of the fuel input by a combination of electrical power generation together with process heat configuration of the power plant.

Another popular and more favorable configuration of the marine gas turbine in the cruise ship market is the COGES propulsion system which integrates electric propulsion motors

with alternators that are driven by a combination of gas turbine units and a steam turbine through superheated steam recovery generators installed in the gas turbine exhaust lines.

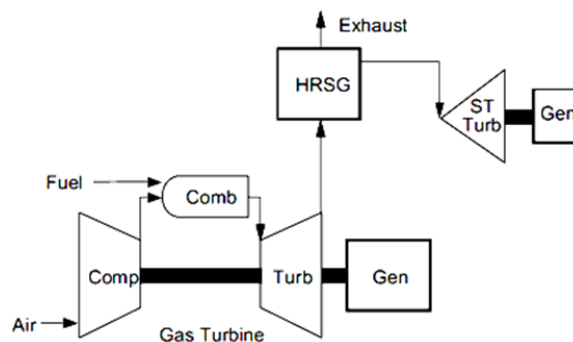

Fig. 1 Component diagram of the combined gas turbine cycle

TABLE I
 COMPARISON OF CONVENTIONAL MARINE POWER PLANTS [3]

Concept	Specific Weight	Fuel Consumption (64MW/25kt/6000nm ship)	Level of Maturity
Diesel(Baseline)	31.7 kg/kW	2800t	Mature
Gas Turbine Mechanical	1.5 – 3.8 kg/kW	3377t – 4564t	Mature
Gas Turbine/Diesel electric	6.5 kg/kW - alternators 6.5 kg/kW – motors 14.5 – 16.8 kg/kW - total	3700t – 5000t (~10% less inferior to Gas Turbine Mechanical)	Fairly Mature
Nuclear electric	29.5 kg/kW 17.6 kg/kW – FC	None	Immature
Fuel Cell electric	6.5 kg/kW - motors 24.1 kg/kW - total	<2800t	Immature

This design concept maintains a constant fuel consumption profile over a wide operating range through the continuous recovery of power by a steam turbine whenever the efficiency of the gas turbine decreases during part load operations. Table I shows the variety of conventional power plant configurations that are possible in the merchant ship industry and their current level of maturity. It reveals that the diesel and the gas turbine engines currently play a dominant role when compared to several other alternative systems.

Of significant importance is another method of achieving a reduction in the fuel consumption per every unit of power that in a further improvement in the part load efficiencies of the gas turbine is the intercooled-recuperated (ICR), which reduces the energy required for the compression process and effectively increases the overall thermal efficiency [3]-[5].

Recently, a techno-economic and environmental assessment that focused on the potential reduction of fuel consumption and pollutant emissions through the configuration of a hybrid system of two vertical axis wind turbines installed on the deck of a vessel in combination with a conventional power plant was conducted and although its performance was also dependent on prevailing climatic conditions, it resulted in a 14% fuel saving through gas turbines, while 16% was achieved when diesel engines were installed [6].

TABLE II
 CHARACTERISTIC FEATURES OF THE CRUISE SHIP MODEL

Parameters	Design Values
Length at Water level, L_{WL} [m]	283.5
Maximum Beam, B [m]	39.0
Average design Draft, T [m]	9.0
Block Coefficient, C_B	0.65
Midship Coefficient, C_M	0.9
Water plane Coefficient, C_{WP}	0.78
Service Speed [knots]	22.0
Propulsion Brake power [MW]	42.0
Service power [MW]	34.0
Froude Number F_n	0.4172
Displacement, Δ [metric Tons]	1,636,347
Wetted surface area [m ²]	20,662.7
Total resistance [N]	2,605,348

Although the GE LM2500 is well known to be powering many cruise ships, there are many other original equipment manufacturers (OEMs) that are also known to be successfully involved in developing and producing aero-derivative engines for cruise ship power projects [7], and with General Electric (GE) being one of the world's largest aero-derivative service providers [8], it may be right to note that its simple cycle LM2500 model is the most widely-applied aero-derivative for patrol boats, corvettes, frigates, destroyers, cruisers, cargo/

auxiliary ships and aircraft carriers by 33 navies worldwide. It has also been recently contracted for the building of a number of new frigates for the Royal Australian navy [9], as illustrated in a typical layout of its combine cycle configuration in Fig. 1 and having a capability to substantially raise the thermal efficiency of its thermodynamic cycle as a fuel saving measure.

II. DATA MODULES FOR THE INVESTIGATION

A. Ambient Temperature and Sea State Data

Generally, the gas turbine is designed in such a way that any deviation from the reference sea level international standard atmosphere (ISA) affects its overall performance significantly. The optimal performance of the marine gas turbine therefore is solely dependent on the local environmental conditions prevailing at any geographical location and time of the vessel's voyage. Whenever there is an increase in the compressor inlet air temperature, it imposes a corresponding degradation in performance. Wet compression and water injection along with other techniques of component and machinery configurations are methods currently in place for performance improvement and as a counter measure to high temperature operating environments.

The temperature and sea state modules in this investigation consist of data from the United Kingdom meteorological office (UKMO) and the United Kingdom Hydrographic office (UKHO). The study has further revealed the effect of even small variations in air temperature on engine power output as it affects the speed and time needed for completing a sea-going voyage if the ship is powered by a gas turbine. In real life, the ship is expected to navigate the sea and encounter off design climatic and hydrodynamic conditions at different locations and at different times as well as seasons of the year.

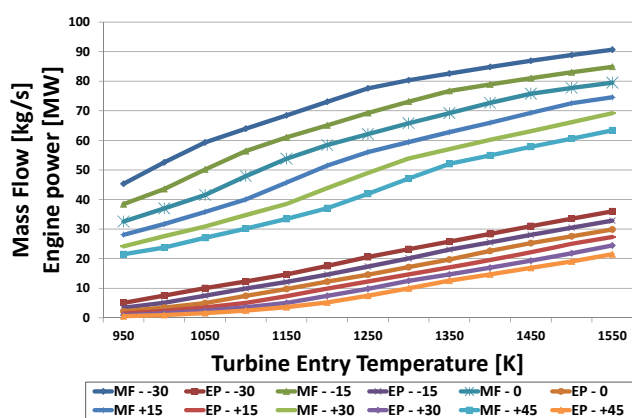

Fig. 2 Variation of power output and air mass flow with projected ambient temperatures

As the gas turbine powered 'voyager of the seas' maneuvers along a selected transit route by passing through both calm and rough operating conditions along the west and north African coast of the Atlantic Ocean and the Mediterranean Sea, five major investigating scenarios were assumed in a MATLAB virtual operating environment. As reflected in the

resulting plots of the investigation, these scenarios include: Calm weather conditions with a smooth ship hull surface (IWCs), Rough weather conditions with an assumed hull surface without fouling (AWCs) as well as three other combinations of rough weather along with hull degradations of 120 μm , (HR1) 240 μm (HR2) and 360 μm (HR3), respectively. In addition to all these scenarios, the seasons of winter, spring and summer were also taken into consideration.

B. The Selected Gas Turbine Module

The thermodynamic cycle of the investigated marine gas turbine has been based on the configuration of the GE LM2500 which is rated at an ISO power of 25 MW. Its design point parameters were simulated as contained in TABLE III; whereby at an installed shaft power of 25 MW, the international standard atmospheric (ISA) conditions were taken to be 15°C and 101.325 kPa. Expectedly, the prevailing meteorological and hydrodynamic changes would significantly affect other vital engine operating parameters during the voyage such as the compressor inlet air mass flow (MF), the fuel flow (FL), pressure ratio (PR), and the engine firing or turbine entry temperature (TET).

In an off-design preliminary evaluation, the engine behavior was considered against the variation of its TET within an ambient temperature range between -30°C and +45°C, as shown in Fig. 2. A simulated result of 37.8% thermal efficiency that corresponds to a specific fuel consumption (SFC) of 221.65 g/kWh was realized at a pressure ratio and mass flow of 18.75 kg/s and 72.5 kg/s, respectively.

Design Parameters	Simulated values
Rated Power output [MW]	25
Turbine Entry Temperature [K]	1505
Overall Pressure Ratio	18.75
Intake Mass flow [kg/s]	72.5
Exhaust Mass Flow [kg/s]	73.54
Exhaust Temperature [K]	804
Thermal efficiency [%]	37.78
SFC [kg/ kWh]	221.65

A typical cycle and component layout that has greatly improved the efficiency and operating ability of one of the passenger liners called "Millennium" is the COGES-type system which combines a couple of gas turbines to a steam turbine for driving electric generators and motors for a final transmission of the drive to the vessel's propeller screws. In its steam turbine circuit, the steam is generated by using the exhaust gases from the gas turbine engines in a waste heat boiler [10] similar to the illustration in Fig. 1. Under the same temperature range, the simulation further determined the variation of the pressure ratio, fuel flow, specific power as well as the turbine entry temperature at the prevailing ISO conditions.

C. The Cruise Ship Model

A ship's resistance is particularly influenced by its speed,

displacement as well as its hull form and total resistance along other specified parameters that describe the geometry of the investigated vessel, as highlighted in TABLE II [11]. With a displacement of over 1.6 million metric tons and having a length of 283.5 m at a maximum beam of 39 m, this passenger vessel is capable of navigating the sea at a speed of 22 knots through a long-haul voyage of 5687 nautical miles within a period of less than 11 days. Three units of the investigated marine gas turbine were determined to be sufficiently adequate for meeting the installed capacity for both propulsion and the hotel load onboard the vessel.

The design of the “Voyager of the Seas” Passenger Cruise Liner operated by the “Royal Caribbean” Consortium [12] was selected as the baseline ship model for the investigation. It is typically designed to overcome a resistance in excess of 2.5 MN under a passenger capacity of over 3,000 along with close to 1,200 crew members on board. The three aero-derivative simple cycle gas turbines that make up the power plant were expected to generate a combined installed power of 75 MW giving it enough redundancy to operate above full load and comfortably transport both passengers and crew on board the vessel as it transits for over a period of 10 days and nights.

It is important to note that the installed power onboard the baseline vessel of the investigation takes 42 MW for propulsion, while the balance of 34 MW is dedicated for the hotel load, giving an installed plant power of 76 MW.

D. The Transit Route Profile

Illustrated in Fig. 3 is the geographical map of the voyage

under consideration. It covers a total distance of 5687 nautical miles when transiting at a speed of 22 knots via the Suez Canal for about 11 days of travel time [13]. An alternative route via the Cape of Good Hope would have been more cost effective by avoiding the extra charges to be incurred before crossing the Suez Canal, but for the disadvantage of covering a longer distance of 7208 nautical miles [14] without any economic benefits. Maritime security concerns around the Horn of Africa together with the general insecurity situation bordering on the Yemeni crisis [15] were observed as a major challenge opposed to the choice of the ‘Cape of Good Hope’ as an alternative route.



Fig. 3 The selected transit route of the investigated vessel [13]

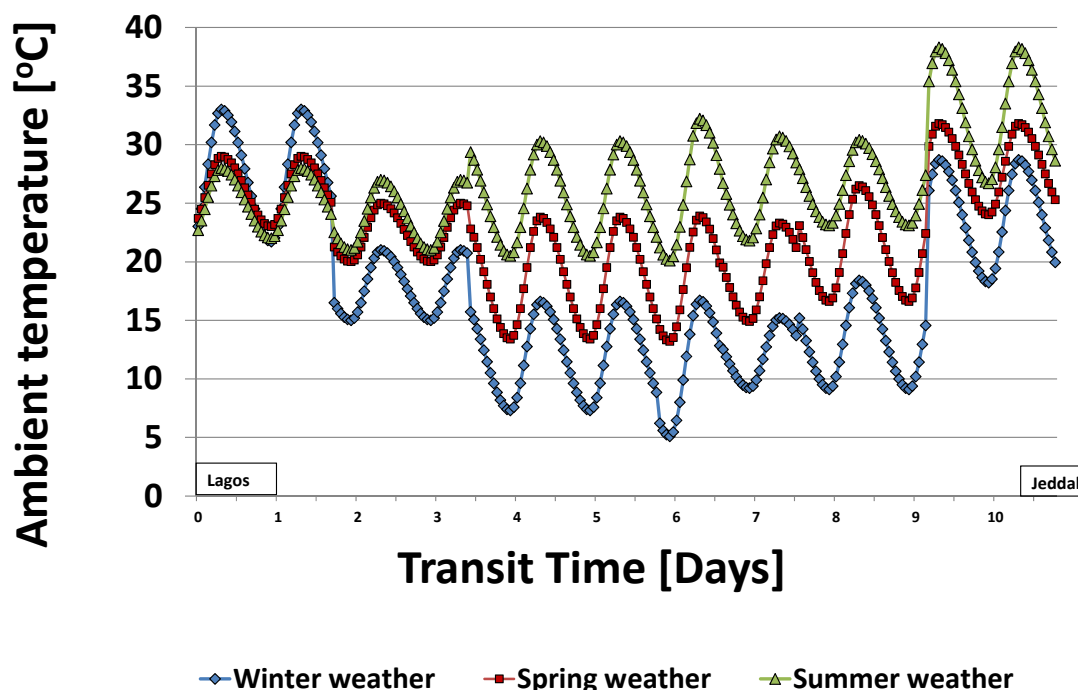

Fig. 4 Ambient temperature variation along the selected transit route

For the selected transit route however, the variation of ambient weather conditions was analyzed with respect to the different seasons as a function of geographical location and

the time, as plotted in Fig. 4 for the three selected seasons.

III. POWER PLANT PERFORMANCE EVALUATION

Examining the performance of the power plant as affected by these environmental changes, the investigation was conducted on the basis of the variety of assumptions. Therefore, as the ship made its way along the virtual route in calm weather, the performance of the propulsion system was detected to have remained consistent at its designed speed of 22 knots throughout the voyage. However, the encounter with rough weather brought about by elevated sea states led to higher hydrodynamic resistance that resulted in increased power demand to sustain performance, as illustrated in Fig. 6. Indeed, the ship speed dropped slightly at locations of higher sea states.

A. Ship Navigation in Calm Weather

An examination of how the changes in ambient conditions affected the engine firing temperature under ideal weather conditions showed that the pattern of TET variation remained

consistent with the ambient temperature changes encountered along the transit route. A change became necessary when the weather became unfavorable, as illustrated in Fig. 5, with just a few days into the voyage around the West African coast where maximum tropical temperatures were as high as 32 °C and 22 °C during the winter. Around the Mediterranean however, the minimum ambient temperature ranged between 18 °C and 5 °C, while the compressor inlet air temperatures ranged between 18 °C and 28 °C on approaching the destination port. During the summer periods and in contrast to the winter weather, tropical temperatures remained lower but rose higher than usual at the Mediterranean, up to as high as 38°C during the day and as low 22 °C at night. The investigation further revealed how hot and cold weather conditions are geographically opposed to each other between the tropical portion of the voyage and that of the Mediterranean Sea.

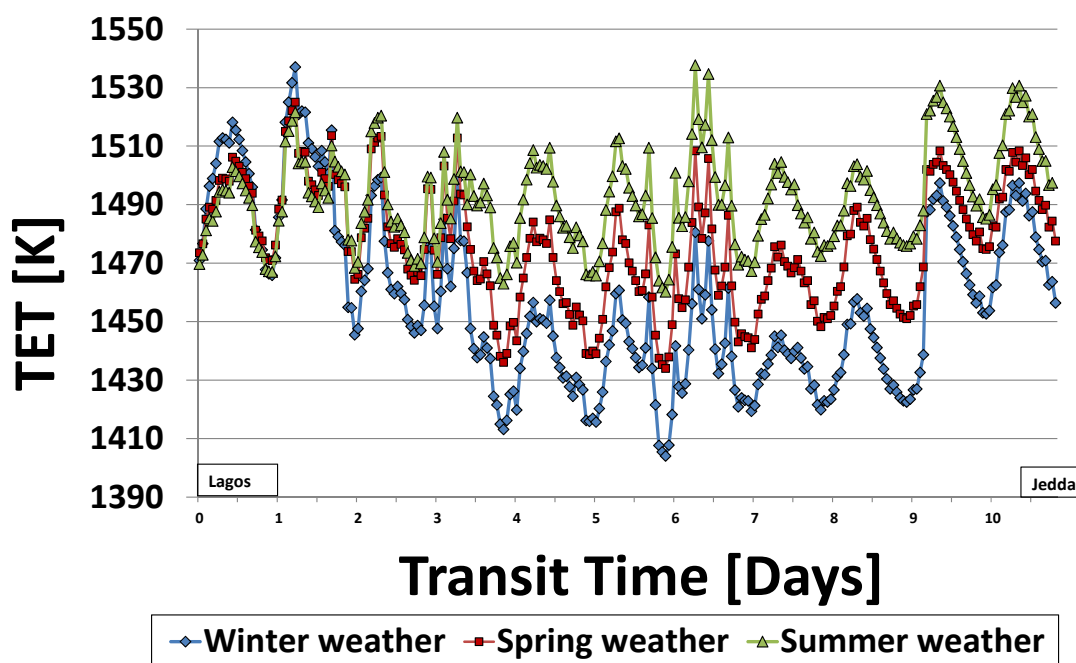

Fig. 5 Seasonal changes in engine firing temperatures

Furthermore, the environmental impact of weather as it affects the specific fuel consumption (SFC) was investigated and found to be dependent on subsisting weather and sea conditions giving between 227 g/kWh and 229 g/kWh in summer time, but with elevated values between 228 g/kWh and 231 g/kWh at its Mediterranean segment for the investigated simple cycle marine gas turbine engine. The research observed that the most unstable pattern of variation took place during the spring season especially around the tropical locations, but it later assumed a summer pattern towards the end of the voyage. Other performance parameters such as thermal efficiency, fuel mass flow, air mass flow and TET were also investigated, but a focus on the brake power shows how it remained steady at 29 MW throughout the voyage, as illustrated and seen in Fig. 6.

A. Ship Navigation in Rough Weather

Under adverse weather conditions (AWCs), the seasonal variation of TET for the power plant during the voyage for all the three seasons was found, as illustrated in Fig. 5. In winter, the full load firing temperature was registered as 1,537 K with a minimum value of 1,404 K. On the contrary during summer, this same maximum temperature was maintained at a different location in the Mediterranean but with a higher minimum value of 1,464 K throughout the voyage. Full load operation of the power plant in the spring season kept the TET at a modest maximum of 1,524 K and a minimum of 1,433 K. The results show how irregular operating conditions affect the ship power plant during operations at full power.

B. Consequence of Hull Fouling

The growth and decomposition of marine plants and animals on the submerged hull surface of the vessel is a common phenomenon that is referred to as ‘fouling’. It is a phenomenon that potentially affects the operational efficiency of the marine gas turbine power plant as it leads to increased fuel consumption and the production and release of millions of tons of greenhouse gases [16]. In practice, the more the thickness of the layer of fouling, the more the power that will be required to keep the ship sailing at the optimal speed due to

the restriction induced by an increased resistance. It is then mandatory for frequent hull maintenance to be conducted, since an increase in the sailing resistance potentially leads to ship speed loss and increased travel times. This investigation has further revealed there is a fuel penalty with a higher fuel consumption and greater emission of greenhouse gases along with other emissions when a gas turbine-powered vessel is operated with a fouled hull with grave consequences of polluting the earth’s atmosphere [17].

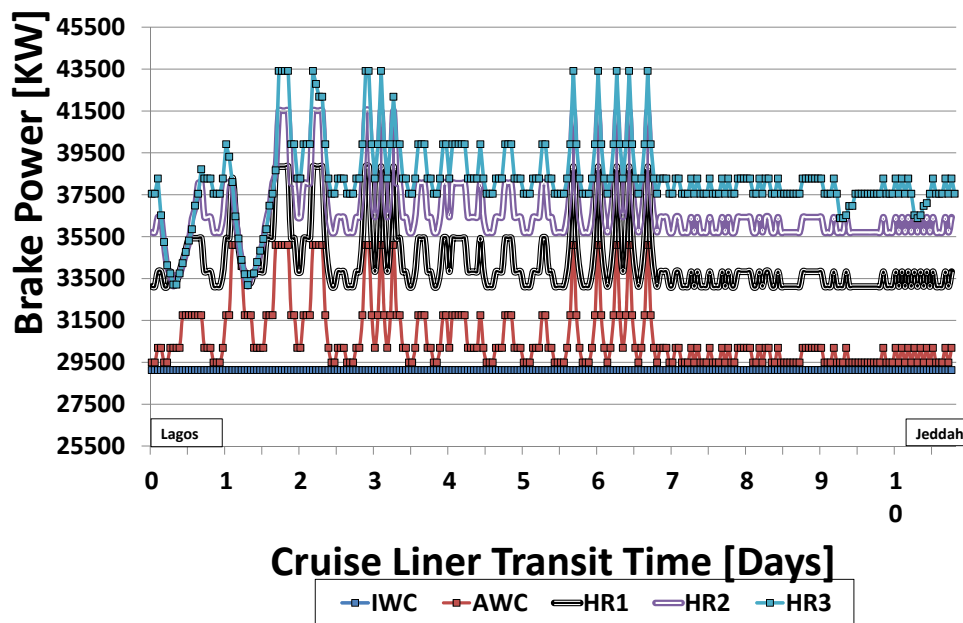

Fig. 6 Variation of brake power for the vessel’s navigation in rough weather

In the present research, therefore, the generation of brake power for overcoming increased resistance as a result of a variety of adverse operating conditions along any transit route has been evaluated, as shown in Fig. 6. Peculiar cases of fluctuations in power between 29.5 MW and 35.5 MW were experienced at certain locations but with an increased fouling of 120 μm , the brake power was found to be ranging between a 33 MW and 36 MW. A further rise in fouling to 240 μm surged the power demand to fluctuate between 35.7 MW and 40 MW, while the highest investigated scenario of 360 μm raised it to between 37.5 MW and 43.4 MW.

The consequence of higher fuel consumption per voyage was also investigated according to the variety of assumptions and plotted in Fig. 7.

IV. CONCLUSION

With the gas turbine in focus, the study has investigated the possibility of undertaking a voyage by way of a cruise ship carrying over 3,000 passengers and enjoying the full benefits of 5-star hotel accommodation on board a passenger ship that is scheduled to last for a little over 10 days. The effect of tropical climate and hydrodynamic parameters on the performance of the gas turbine power plant have been

investigated, but further investigation on the impact of the gas turbine with special focus on the pollutant emissions impacting the environment negatively along the selected maritime route is recommended for further work. The economic potentials of this alternative also require to be further evaluated with a focus on the sub region that has been covered in the investigation. The study may be further extended to investigate the application of advanced gas turbine cycles when compared to the simple cycle considered in the current study.

With the marine gas turbine installed as the vessel’s propulsion and hotel power plant, the effect of a variety of atmospheric and hydrodynamic operating conditions on the overall performance of the marine gas turbine has been evaluated by the use of daily ambient conditions as the main input data. The meteorological and hydrographic consequences of encountering different environmental changes as well as a grossly fouled and poorly maintained submerged hull surface have been analyzed to show the fuel consumption penalty resulting from it. The extreme high power density and the very high operating speeds of this option, along with a nearly vibration-free machinery plant that gives rise to a potentially quieter and smoother, is adjudged to be an added advantage to the marine gas turbine application in

the cruise ship industry. Furthermore, this technology has the potential of easily being exploited to create extra accommodation or public spaces when installed on a cruise ship.

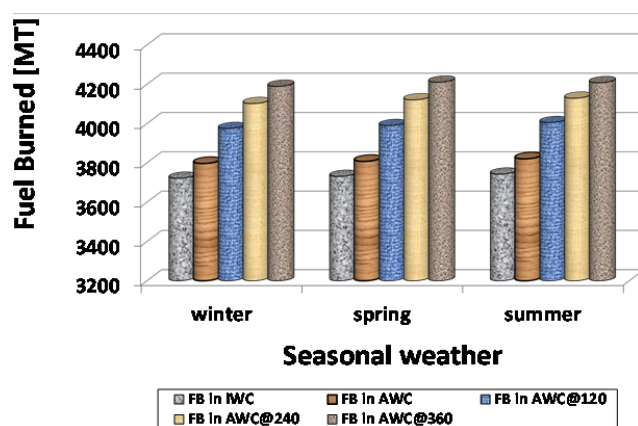

Fig. 7 Seasonal evaluation of the voyage fuel consumption

REFERENCES

- [1] Dawn Santoianni, "Power plant performance under extreme ambient conditions," *WÄRTSILÄ Tech. J.*, pp. 22–27, 2015.
- [2] D. Woodyard, *Pounder's Marine Diesel Engines and Gas Turbines Eighth edition*, no. 8. 2004.
- [3] C. B. McKesson, "Alternative Powering for Merchant Ships: Task 2 – Survey of Available Alternative Powerplants for Container Ships," 2000.
- [4] M. U. Bonet; P. Pilidis, "Techno-Economic and Environmental Assessment of an Intercooled-Recuperated (ICR) Marine Gas Turbine for Powering a LNG Carrier," *Nav. Eng. J.*, vol. 129, no. 1, p. 77–86 (10), 2017.
- [5] M. U. Bonet and P. Pilidis, "Comparative Assessment of Two Thermodynamic Cycles of an aero-derivative Marine Gas Turbine," *IOSR J. Mech. Civ. Eng.*, vol. 6, no. 3, pp. 76–81, 2013.
- [6] L. Talluri, D. K. Nalianda, K. G. Kyprianidis, T. Nikolaidis, and P. Pilidis, "Techno economic and environmental assessment of wind assisted marine propulsion systems," *Ocean Eng.*, 2016.
- [7] M. U. Bonet, "Techno-environmental assessment of marine gas turbines for the propulsion of merchant ships," 2011.
- [8] GE, "Powering a New Class of Frigates - RJE Global team on Australian navy project," *Diesel & Gas Turbine Worldwide*, pp. 1–2, Sep-2017.
- [9] GE, "Fact Sheet (2016) - LM2500 Gas Turbine (60 Hz) 22-33 MW." GE Power, 2015.
- [10] M. Dzida, "Possible Efficiency Increase of Ship Propulsion and Marine Power Plant with the System Combined of Marine Diesel Engine, Gas Turbine and Steam Turbine," in *Advances in Gas Turbine Technology*, E. Benini, Ed. InTech, 2011, pp. 45–69.
- [11] E. C. Rawson, K. J.; Tupper, *Basic Ship Theory- Volume 1*, Fifth., vol. 1, no. 4. OXFORD: Butterworth Heinemann, 2001.
- [12] L. Kai, "Ship Design and Construction," in *Passenger ships*, Society of Naval Architects and Marine Engineers, 2004, pp. 37–39.
- [13] Distances.com, "Ports.com seaports: info, marketplace," *Ports.com*, 2017. (Online). Available: <http://ports.com/sea-route/port-of-lagos-apapa,nigeria/jeddah-islamic-port,saudi-arabia/>. (Accessed: 10-Nov-2017).
- [14] Sea-Distances.Org, "Sea Distances and Voyage calculator," *sea-distances.org*, 2017. (Online). Available: sea-distances.org. (Accessed: 06-Nov-2017).
- [15] T. Potgieter, "The Maritime Security Quandary in the Horn of Africa Region: Causes, Consequences," *East African Hum. Secur. Forum*, no. January, p. 21, 2008.
- [16] A. Nobel, "Coating Technology: What is Fouling?," *International Marine Coatings*, p. 2, 2014.
- [17] P. R. Cabezas and G. Kasoulides, "International Maritime Organization," *Int. J. Mar. Coast. Law*, vol. 3, no. 3, pp. 235–245, 2004.