

# A Fuzzy Control System for Reducing Urban Stormwater Runoff by a Stormwater Storage Tank

Pingping Zhang, Yanpeng Cai, Jianlong Wang

**Abstract**—Stormwater storage tank (SST) is a popular low impact development technology for reducing stormwater runoff in the construction of sponge city. At present, it is difficult to perform the automatic control of SST for reducing peak flow. In this paper, fuzzy control was introduced into the peak control of SST to improve the efficiency of reducing stormwater runoff. Firstly, the design of SST was investigated. A catchment area and a return period were assumed, a SST model was manufactured, and then the storage capacity of the SST was verified. Secondly, the control parameters of the SST based on reducing stormwater runoff were analyzed, and a schematic diagram of real-time control (RTC) system based on peak control SST was established. Finally, fuzzy control system of a double input (flow and water level) and double output (inlet and outlet valve) was designed. The results showed that 1) under the different return periods (one year, three years, five years), the SST had the effect of delayed peak control and storage by increasing the detention time, 2) rainfall, pipeline flow, the influent time and the water level in the SST could be used as RTC parameters, and 3) the response curves of flow velocity and water level fluctuated very little and reached equilibrium in a short time. The combination of online monitoring and fuzzy control was feasible to control the SST automatically. This paper provides a theoretical reference for reducing stormwater runoff and improving the operation efficiency of SST.

**Keywords**—Stormwater runoff, stormwater storage tank, real-time control, fuzzy control.

## I. INTRODUCTION

WITH rapid urbanization, a series of water resource management problems has emerged in China, among which floods and subsequent water-logging following rainstorms are serious problems [1]-[3]. To alleviate the situation, a number of developed countries have referred some initiatives such as Low Impact Development (LID) in the USA [4], Sustainable Urban Drainage Systems (SUDS) in the UK [5] (CIRIA, 2000), and Water Sensitive Urban Design (WSUD) Australia [6] (Lloyd, 2001). After Beijing flood disaster on 21 July 2012, stormwater resource management draw more attentions of government and research institutions. Combined with the concept of LID, President Xi put forward sponge city

Pingping Zhang is with the State Key Laboratory of Water Environment Simulation and Beijing Engineering Research Center for Watershed Environmental Restoration & Integrated Ecological Regulation, School of Environment, Beijing Normal University, Beijing 100875, China (e-mail: zpingping10@126.com).

Yanpeng Cai is with the State Key Laboratory of Water Environment Simulation and Beijing Engineering Research Center for Watershed Environmental Restoration & Integrated Ecological Regulation, School of Environment, Beijing Normal University, Beijing 100875, China (corresponding author, e-mail: 15510727961@163.com).

Jianlong Wang is Key Laboratory of Urban Stormwater System and Water Environment (Beijing University of Civil Engineering and Architecture), Ministry of Education, Beijing 100044, China (e-mail: 1229149616@qq.com).

on 12 December 2013, then two batches of pilot cities (30 cities) were selected for sponge city construction in 2015 and 2016 gradually. According to the principle of seepage, stagnation, storage, net, use and discharge, many LID technologies were adopted in the sponge city construction, among which storage tank is popular in reducing stormwater runoff. However, due to the randomness of stormwater, it is difficult to reduce runoff peak flow accurately by stormwater storage tanks, and there is still lack of research in this area so far. Therefore, it is a must to carry on the research on the real time control (RTC) of reducing peak flow by SSTs.

SSTs have become an integrated part of the sponge city construction, can attenuate the peak flow by storing one part of the runoff volume and prolonging the residence time. In recent years, a lot of cities in China have constructed SSTs such as flood storage tank of Beijing, combined sewer overflow storage tank of Shanghai, runoff pollution storage tank of Kuming. Most of researches on storage tanks mainly were the design, pollutants removal effect, and operation assessment. Mao showed the function and structures design of Changping detention tank [7]. Tan et al. [8] adopted a computer model for evaluating the operation efficiency of an initial stormwater detention tank. Xu et al. [9] showed that the optimization and application of initial rainwater on-line monitoring system for reducing runoff pollution, while there were few researches on the automatic control of storage tank for reducing peak flow.

RTC technology had been mainly used on the combined sewer system for reducing runoff pollution. Some developed countries adopted the RTC technology since 1960s, and had a positive efficiency on overflow pollution control [10]. Besides, the RTC technology also was used on the aspect of water control. In 1990s, through adopting RTC on combined sewer system, the average discharge of 15%-55% from total rainfall event could be reduced [11]. Some research showed that the method of adopting RTC for reducing overflow discharge had a close connection with specific storage capacity [12]. Since the 21<sup>st</sup> century, to make the best solution of controlling water quality and water quantity by adopting RTC, the operating efficiency of sewage treatment plant, the storage capacity of storage tank, and the sensitivity of receiving water have been considered synthetically [13]. Fuzzy control, as one kind method of RTC, does not need to obtain the accurate mathematical model of the control object, is independent and robust, and could be designed according to the rules of expert knowledge and artificial experience [14]. Fuzzy control is suitable for large, nonlinear, time-varying and time delay systems with disturbances and parameter variations [15]. Therefore, fuzzy control can be used on the storage tank for

reducing the peak flow accurately.

In this paper, fuzzy control was introduced into the peak control of storage tank. First, the design of storage tank was investigated. A catchment area and return period was assumed, then a storage tank model was manufactured, and the storage capacity was verified. In addition, the control parameters of the storage tank were analyzed. Finally, fuzzy controller of the storage tank was designed. This paper provides the theoretical reference for reducing stormwater runoff and improving the operation efficiency.

## II. THE THEORETICAL BASIS OF REDUCING STORMWATER RUNOFF BY THE STORAGE TANK

### A. The Design of Storage Tank

SST, as an efficiency measure of reducing stormwater runoff, can be set at any location in the basin. To reduce the stormwater runoff, the control measures of source, process and end should be combined, then the position of storage tank can be decided according to the runoff flow of the whole rainfall process. The position of storage tank has a great influence on the efficiency of reducing the stormwater runoff. SST, on the drainage main pipe (canal), is to reduce the pressure of downstream drain pipe by cutting the stormwater runoff of the upstream, branch pipe, and the nearest rainwater outlet.

The type of storage tank also can be classified by the purposes, the connection modes or others. According to the purpose of the storage tank, it can be divided into pollution control storage tank, peak flow cutting storage tank, and collection storage tank. According to the regulation of online/offline, storage can be divided into online and offline storage. According to the overflow mode, storage can be divided into the pool overflow and overflow pool. According to the relationship between storage tanks and pipelines, storage tanks and pipelines can be divided into two kinds of series and parallel connection pipe.

A simplified model of storage tank is showed in Fig. 1. These storage tanks have the function of stormwater retention and detention [16]. Combined with the hydrologic progress curve and simplified model, the mode of the influent and effluent of the storage tank can be judged preliminarily. In Fig. 1 (C), the stormwater runoff is stored first, then discharged when the storage tank is full. In Fig. 1 (D), the outflow is set in front, when the stormwater runoff exceeds the designed inflow capacity, the discharge is started. In Fig. 1 (E), the main purpose of the storage tank is to regulate flood peak. The outlet is set in the bottom of the stormwater tank, and the detention time would be extended. In Fig. 1 (F), when the water is small, the stormwater runoff can be discharged directly through the pipeline. When the flow reaches a certain control value, the flood peak flow can be stored first, then discharged slowly or utilized.

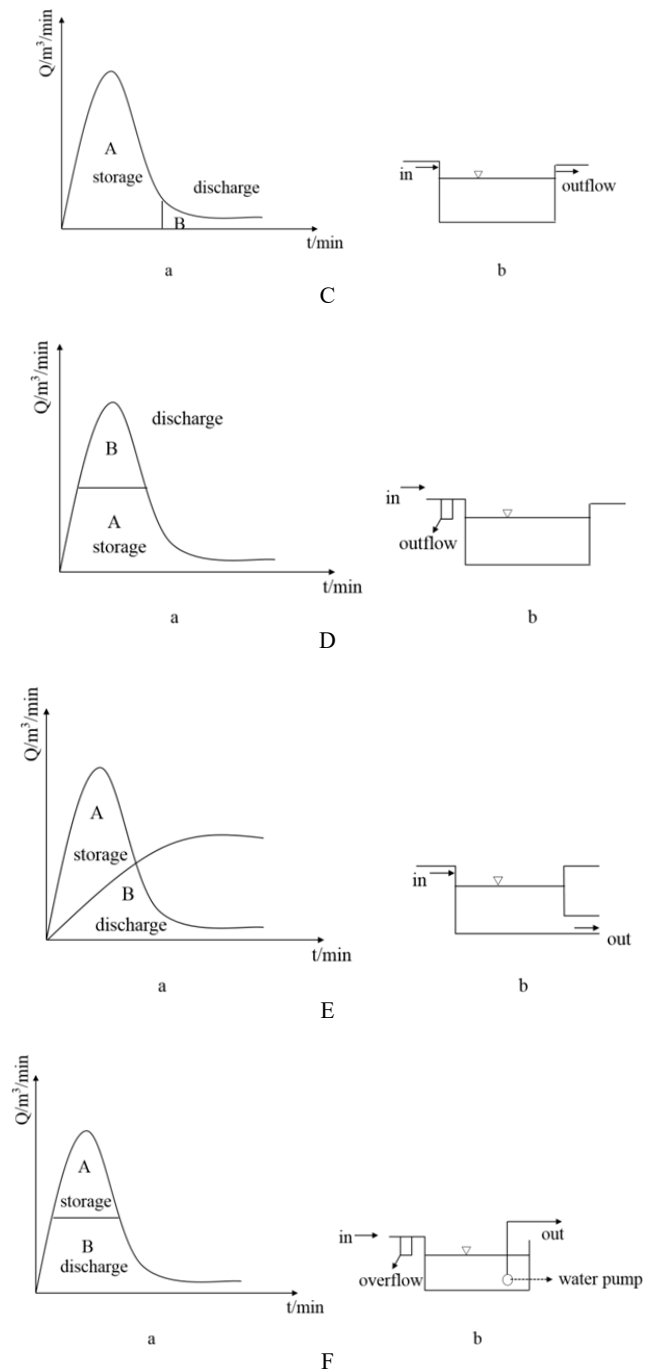

Fig. 1 The simplified model of storage tank based on reducing the stormwater runoff (A and B are the storage and discharge of the stormwater runoff respectively; a and b are the hydrologic progress curve and the simplified model of storage tank respectively; C and D are the storage tank based on the stormwater harvesting and E and F are the storage tank based on regulating flood peak)

According to the basis of different types of storage tank, a simulated experimental device of storage tank was manufactured (Fig. 2). The device included the water tank, water pump, overflow weir, storage tank, and water level meter. The water tank was a distributing tank, water pump was used to control the flow velocity by a buoy flow meter, the overflow

weir was set in the front and back of storage tank, and the online water level meter was set in the storage tank to monitor the water level in real-time. The area of the SST was 2 m<sup>2</sup>, accounting for 20% of the service area, the runoff coefficient is

0.8. The reference curve of different return periods is shown in Fig. 3. The rainfall data of different return period were from a hydrologic manual of Beijing, China.

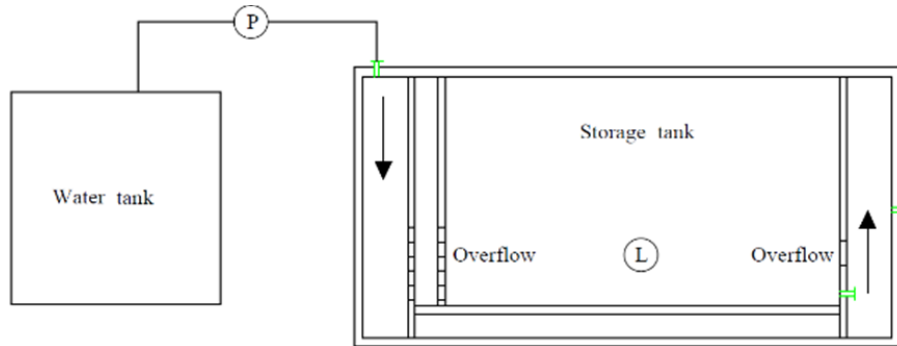

Fig. 2 The simulated experimental device of storage tank (P is the water pump; the arrow direction is the flow direction; L is the online water level meter)

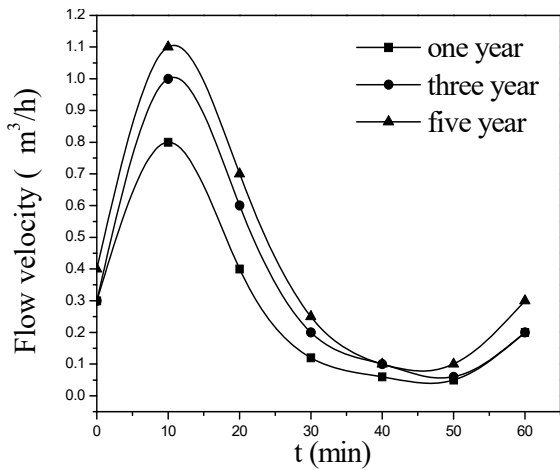
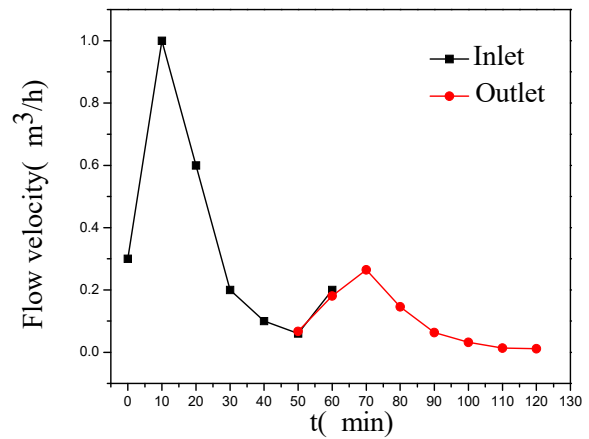
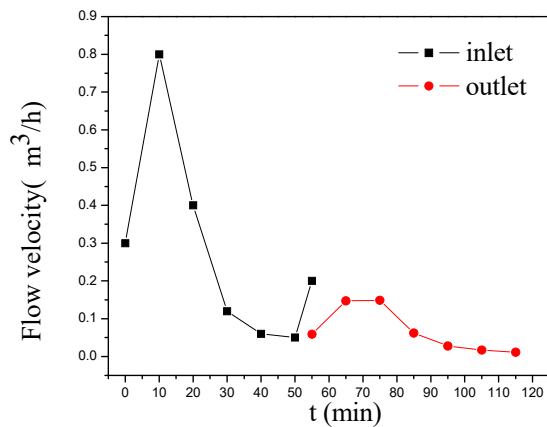

Fig. 3 The flow velocity under different return periods



(b)



(a)

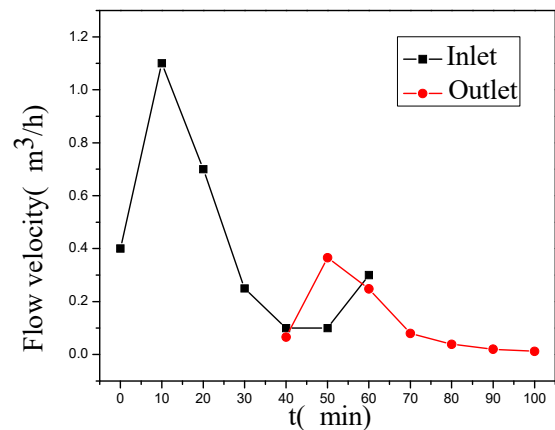

(c)

Fig. 4 The flow velocity change curves of different return periods from the outlet of the storage tank (a: one-year return period, b: three year return period, c: five year return period)

According to the different return periods (one year, three years, five years), the flow rate at inlet and outlet of the storage

tank was shown in Fig. 4. From the figure, the residence time under the return periods of one year, three years and five years were about 55 min, 50 min and 40 min respectively, the peak reduction rates were 81.39%, 73.57% and 66.76%, respectively, and the total reduction rates were 75.50%, 68.84%, 71.87% respectively. When the return period become larger, the residence time of water in the storage tank became shorter. Under one-year return period, the peak reduction rate and the total reduction rate were the largest. The results show that the storage tank has the effect of delayed peak control and storage by increasing the detention time.

### B. The Influencing Factors of Reducing the Stormwater Runoff by the Storage Tank

According to the storage experiments of storage tank, the storage tank has the effect of delayed peak control and storage by increasing the detention time. In practical engineering applications, when the heavy rain happens, the storage tank based on cutting the peak flow could reduce the peak flow by adjusting the opening of the inlet and outlet valve (inlet and outlet were all open). When the medium-small rainfall events happen, and storage tank has enough storage capacity, the stormwater runoff can be stored in the storage tank, then discharged when no rain. The parameter of rainfall ( $Q_i$ ) and pipe flow ( $Q_s$ ) have a great influence on the inflow time of storage tank. Based on the parameter of rainfall ( $Q_i$ ) and the pipe flow ( $Q_s$ ), the time of stormwater runoff into storage tank can be decided.

When  $Q_i > Q_s$ , the pipe is in full pipe flow state and will generate overflow, a lot of rain could not be discharged in time, then large surface runoff will produce. This situation will produce a large peak, the storage tank can reduce the peak value by opening the inlet and outlet simultaneously.

When the flow decreases, the storage tanks can store a part of stormwater and improve the storage capacity effectively. The water level of the storage tank ( $T_L$ ) can judge the storage capacity, when the inflow amount exceeds the storage capacity, the storage tank with an overflow weir can play an important role.

When  $Q_i = Q_s$ , the rainfall is almost equal to the pipeline flow, the pipeline is basically full pipe flow state, will produce less overflow. Due to the stormwater flush, the sediment in the pipeline will be washed out. In this situation, two storage tanks should be set, the first is set for reducing the stormwater runoff pollution, the second one was for cutting peak and collecting stormwater runoff.

When  $Q_i < Q_s$ , the rainfall is less than the pipeline flow, the stormwater runoff basically can be discharged through a pipeline. When there are rivers, lakes or other water drainage pipeline nearby, stormwater runoff can be discharged into the nearby water, and the water has the function for reducing the peak of stormwater runoff.

### C. The RTC Parameters of Storage Tank Based on Reducing the Stormwater Runoff

According to the theory method construction of reducing the stormwater runoff, rainfall ( $Q_i$ ), pipeline flow ( $Q_s$ ), the influent

time ( $t$ ) and the water level in the storage tank ( $T_L$ ) can be used as RTC parameters.

For a period of time, the runoff formula can be expressed as:

$$Q_i = \int_0^t \varphi \cdot q \cdot F \quad (1)$$

where  $Q_i$  is the total amount of runoff in a period of time ( $m^3$ ),  $\varphi$  is the runoff coefficient,  $q$  is the rainfall intensity (mm/min), and  $F$  is the catchment area ( $hm^2$ ).

$Q_0$  is the initial rainfall,  $t_{mid}$  is the time when the runoff reaches the maximum, and  $\frac{dQ_i}{dt_{mid}} = 0$ , then  $t_{mid}$  and  $Q_{max}$  can be obtained. The influent time can be decided by the storage volume, the pipeline flow meter and rain gauge are located at the distance from the storage tank, so the reaction time should be considered. Assuming that  $t_1$  is the reaction time, then  $t_1 = \frac{L}{Q_i}$ . The influent time ( $t$ ) and the duration time ( $t_2$ ) can be presented in (2) and (3):

$$t = \lambda t_{mid} + t_1 \quad (2)$$

where  $t$  is the time from the beginning of the runoff to the water into the storage tank, that is the influent time,  $\lambda$  is a constant ( $0 < \lambda < 1$ ), which is can be determined according to the storage capacity of storage tank.

$$t_2 = \beta t_{mid} \quad (3)$$

where  $t_2$  is the continuous influent time, and is determined by the rainfall and storage capacity,  $\beta$  is a constant.

In addition, the influent time can be calculated by the effective volume of the storage tank. The method of triangular process line can be adopted to calculate the volume of storage tank [17], and the formula is shown in (4). The principle of the triangular process line method is shown in Fig. 5. This formula involves the effective volume, peak flow at inlet and outlet, and the influent time of the storage tank, then the peak flow and influent time of the storage tank can be used as the RTC parameters. So, the influent and effluent mode of stormwater runoff into storage tank can be determined.

$$V = 0.5 T_i (Q_r - Q_0) \quad (4)$$

where  $V$  is the volume of storage tank ( $m^3$ ),  $Q_i$  is the inflow peak flow ( $m^3/s$ ),  $Q_0$  is the outflow peak flow ( $m^3/s$ ), and  $T_i$  is the inflow duration (h).

### A. The RTC System of Storage Tank Based on Reducing the Stormwater Runoff

On-line pipeline flowmeter and rain gauge was located at a distance of  $L$  from the storage tank, and on-line water level meter was placed in the storage tank. Rain gauge can record the rainfall ( $Q_i$ ), on-line pipe flowmeter can be used to obtain the pipeline flow ( $Q_s$ ), and on-line water level meter can judge the storage capacity of storage tank. The schematic diagram of RTC system based on peak control storage tank is shown in Fig. 6.

The information of rain gauge, on-line pipeline flowmeter, on-line flow meter Q1 and Q2, and on-line water level meter was contacted with control platform. The runoff information calculated from the rainfall was compared with the pipeline flow. According to the triangular process line method, the influent and effluent mode and the number of storage tank can be determined. The influent time and duration time can be adopted to determine the valve opening of the storage tank. The signal of water level can be input into the control platform. When the liquid level is too high, the water pump can be controlled by a control platform, and water can be driven into the nearby water body or other storage facilities.

In addition, the signal of the maximum pipeline flowmeter can be transmitted to the control platform to make the inlet valve open. The on-line flow meter Q1 and Q2 are placed in both sides of the storage tank, are used to judge the peak flow of influent and effluent, then the signal can be input into the control platform.

Through the judgement for the peak flow, combined with the triangular hydrograph method, the influent time and duration time can be determined. The water level can reflect the storage capacity of storage tank. When at a low level, the inlet valve

can be kept open, when at a high water level, the inlet and outlet valve can be open simultaneously, and the water in the storage tank can be driven into the nearby water or other storage facilities by pump.

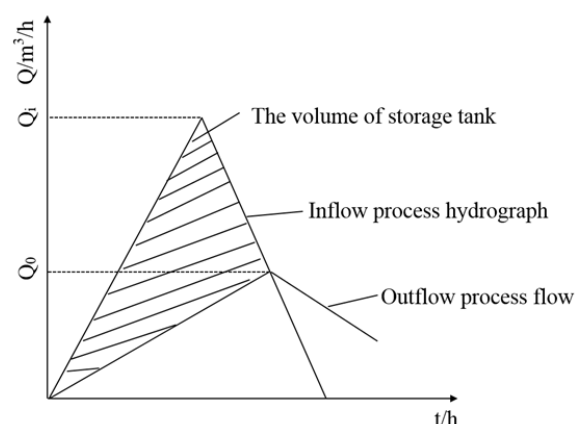

Fig. 5 Schematic diagram of the triangular hydrograph method ( $Q_i$  is the inflow peak flow and  $Q_0$  is the outflow peak flow)

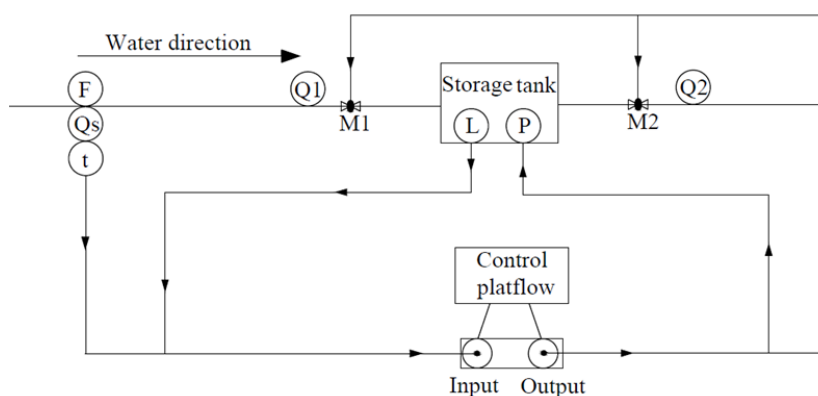

Fig. 6 The schematic diagram of RTC system based on peak control storage tanks (F is the rain gauge,  $Q_s$  is the on-line pipeline flowmeter, t is the influent time, Q1 and Q2 are the on-line flowmeter, M1 is the inlet valve, M2 is the outlet valve, L is the on-line water level meter, and P is the water pump)

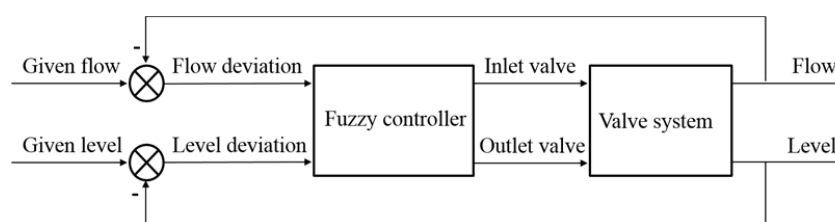

Fig. 7 The structure diagram of the fuzzy control system

### III. FUZZY CONTROL OF THE STORAGE TANK

Fuzzy control system, as a kind of RTC system, is an intelligent control system. It is a feedback control system consisted of computer control technology, and is based on the theory of fuzzy mathematics, representation of fuzzy language, and the rule reasoning of fuzzy logic [14]. Fuzzy control does not need to obtain accurate mathematical model of control object. It is independent and robust, but it should be designed

according to expert knowledge and decision rules of artificial experience. Fuzzy control has been widely used in many aspects in China, such as irrigation water quantity of urban turf [18], dissolved oxygen control in sewage treatment control [19], automatic dosing system in waterworks and water level control [20], [21]. Fuzzy controller, also called fuzzy logic controller, is the core of fuzzy control system. The performance of a fuzzy control system depends mainly on the structure of the

fuzzy controller, the fuzzy rules, the inference synthesis algorithm and the fuzzy decision-making method.

*A. The Design of Fuzzy Controller*

The structure diagram of the fuzzy control system is shown in Fig. 7. It is a control system of double input and double output. The input variables were the influent flow and water level of the storage tank, then these data were input into the fuzzy controller to control the openness of the inlet and outlet value. The fuzzy controller was edited by the fuzzy toolbox in MATLAB.

The entrance flow and water level of the storage tank in fuzzy controller were divided into three fuzzy subsets respectively, which both were high, medium and low, the domain of them were [-1,1], and the membership function were trimf. The openness of the inlet and outlet value was divided into five fuzzy subsets respectively, which both were close fast, close slow, steady, open slow, and open fast, the domain was [-1,1], and the membership function was trimf. The control rules of fuzzy systems were shown in Tables I and II. The nine fuzzy control rules were expressed:

- (1) If (flow is low) and (level is low) then (inlet is close) (outlet is close).
- (2) If (flow is low) and (level is medium) then (inlet is close) (outlet is close).
- (3) If (flow is low) and (level is high) then (inlet is close) (outlet is steady).
- (4) If (flow is medium) and (level is low) then (inlet is open) (outlet is close).
- (5) If (flow is medium) and (level is medium) then (inlet is open) (outlet is steady).
- (6) If (flow is medium) and (level is high) then (inlet is steady) (outlet is steady).
- (7) If (flow is high) and (level is low) then (inlet is open) (outlet is close).
- (8) If (flow is high) and (level is medium) then (inlet is steady) (outlet is steady).

- (9) If (flow is high) and (level is high) then (inlet is steady) (outlet is open).

By using the surface observer window (surface) in MATLAB, we can see whether the expected value of the fuzzy controller is located near the center of the output space of the fuzzy control. If the expectation value exceeds 20%, the membership function and the control rules need to be readjusted.

TABLE I  
 THE OPENNESS OF THE INLET VALUE

| Flow Level | Low        | Medium     | High       |
|------------|------------|------------|------------|
| Low        | close Fast | close Fast | close Fast |
| Medium     | open Fast  | Steady     | open Slow  |
| High       | open Fast  | Steady     | open Slow  |

TABLE II  
 The Openness of the Outlet Value

| Flow Level | Low        | Medium     | High      |
|------------|------------|------------|-----------|
| Low        | close Fast | close Fast | open Fast |
| Medium     | close Fast | Steady     | open Slow |
| High       | close Slow | open Slow  | open Fast |

*B. The Fuzzy Control System*

The fuzzy control system of storage tank consists of a storage tank, online flowmeter, and online liquid level meter. By the Simulink in MATLAB, the structure diagram of the fuzzy control system is shown in Fig. 8. The structure diagram of the fuzzy control rule was shown in Fig. 9. Through online monitoring the flow velocity and water level of the storage tank, using the method of fuzzy control, the inlet and outlet value is controlled to reduce the stormwater runoff. The response curves of flow velocity and water level fluctuate very little and reach equilibrium in a short time. Combined with online monitoring and fuzzy control, the stormwater runoff can be reduced effectively by the stormwater tank.

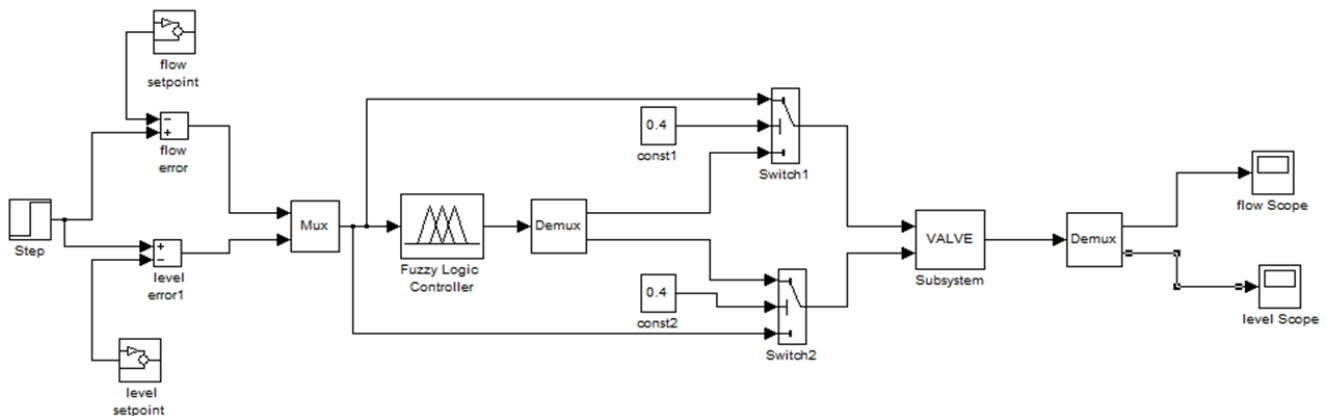

Fig. 8 The structure diagram of the fuzzy control system of storage tank

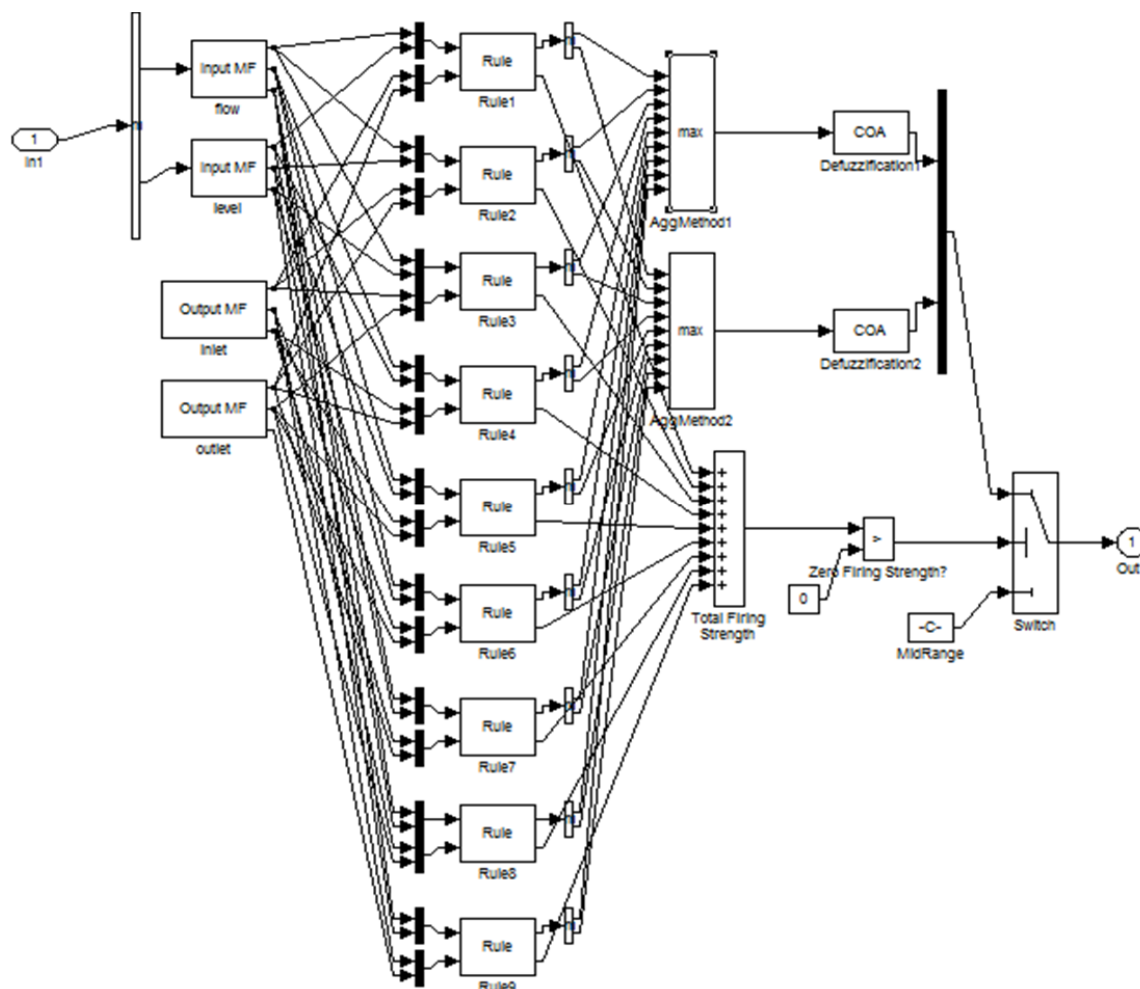

Fig. 9 The structure diagram of the fuzzy control rule of the storage tank

#### IV. CONCLUSIONS

Firstly, through the investigation for the design of the storage tank, a simulated experimental device of storage tank was manufactured. Under the different return periods (one year, three years, five years), the storage tank has the effect of delayed peak control and storage by increasing the detention time. Secondly, according to the analysis of the influencing factors of reducing the stormwater runoff by the storage tank, rainfall ( $Q_i$ ), pipeline flow ( $Q_s$ ), the influent time ( $t$ ) and the water level in the storage tank ( $T_L$ ) could be used as RTC parameters, then the schematic diagram of RTC system based on peak control storage tanks was established. Finally, fuzzy controller of the storage tank was designed, and the influent flow and water level of storage tank was adopted as the input parameters, the response curves of flow velocity and water level fluctuate very little and reach equilibrium in a short time. Therefore, the method of fuzzy control can be adopted onto the storage tank to reduce the stormwater tank effectively.

#### REFERENCES

[1] Weng, Q., "Modeling urban growth effects on surface runoff with the integration of remote sensing and gis." *Environmental Management*, 2001, 28(6), 737-748.

[2] Cai, Y. P., Huang, G. H., Tan, Q., & Yang, Z. F. "An integrated approach for climate-change impact analysis and adaptation planning under multi-level uncertainties. part i: methodology." *Renewable & Sustainable Energy Reviews*, 2011, 15(6), 2779-2790.

[3] Chen, Y., Zhou, H., Zhang, H., Du, G., & Zhou, J. "Urban flood risk warning under rapid urbanization." *Environmental Research*, 2015, 139, 3.

[4] Hinman, C., "Low Impact Development: Technical Guidance Manual for PugetSound." Washington State University, USA, 2005.

[5] CIRIA, "Sustainable Urban Drainage Systems—Design Manual for Scotland and Northern Ireland," Report No. C521. CIRIA, Dundee, Scotland, 2000

[6] Lloyd, S.D., *Water sensitive urban design in the Australian context*. In: Synthesis of a conference held 30–31 August 2000, Melbourne, Australia, Cooperative Research Centre for Catchment Hydrology Melbourne, Australia, pp.1–26, 2001.

[7] Mao, W. H., "Research on design and sand removal process of changping detention tank." *Construction & Design for Project*, 2011.

[8] Tan, Q., Tian, L. I., Zhang, J. P., & Shi, Z. B. "Evaluation of computer model for operation efficiency of initial rainwater detention tank." *China Water & Wastewater*, 2007

[9] Li, X. U., Kai-Hua, Y. U., Ding, M., Cheng, J., & Wang, H., "Optimization and preliminary application of initial rainwater on-line monitoring system." *China Water & Wastewater*, 2014.

[10] Tang, H., & Tian, L. I., "Present situation and development trend of real time control of urban drainage system." *China Water & Wastewater*, 2009, 25(24), 11-14.

[11] Campisano, A., Ple, J. C., Muschalla, D., & Vanrolleghem, M. P. P. A. (2013). Potential and limitations of modern equipment for real time control of urban wastewater systems. *Urban Water Journal*, 10(5),

- 300-311.
- [12] Xiao-Yan, L. U., Tian, L. I., & Qian, J., "Application of pre-assessment methods for real-time control of sewer system in hefei city." *China Water & Wastewater*, 2012, 28(7), 56-55.
  - [13] Schütze M, Einfalt T., "Off-line development of RTC strategies–A general approach and the Aachen case study", *Eighth International Conference on Urban Storm Drainage*, 1999, 30: 410-417.
  - [14] Passino, K. M., & Yurkovich, S., "Fuzzy Control." Tsinghua University Pres, 2001.
  - [15] Gu, Y., Wang, H. O., Tanaka, K., & Bushnell, L. G., "Fuzzy control of nonlinear time-delay systems: stability and design issues." *American Control Conference*, 2001. Proceedings of the (Vol.6, pp.4771-4776 vol.6). IEEE, 2002.
  - [16] Li, J., "On regulation, reservation and practical calculation in urban rainwater utilization." *Water & Wastewater Engineering*, 2007, 33(2), 42-46.
  - [17] Xu haishun., "Urban district ecological rainwater infrastructure planning theory, method and application research (D)." Shanghai: East China Normal University, 2014.
  - [18] Wang, Y., & Han, J. G., "Study on fuzzy control system for irrigation water quantity of urban turf." *Water Saving Irrigation*, 2009.
  - [19] Liu, Z., Li, W., Wang, X., Su, Z., Lian, X., & Xie, D., "A control method of dissolved oxygen in sewage treatment based on fuzzy-smith." *Artificial Intelligence & Computational Intelligence. aici.international Conferenc*, 2009, 3, 569-572.
  - [20] Zhou, Z., He, Q., & Sun, G., "Design of automatic control for chemical dosing system in changcheng waterworks." *Water Technology*, 2013.
  - [21] Lei, J. L., Huang, Z. X., & Jing-Yu, A. N., "Application of matlab in the fuzzy control system for water level in boiler." *Journal of Baoji University of Arts & Sciences*, 2008.