

Application of Artificial Neural Network in Assessing Fill Slope Stability

An-Jui. Li, Kelvin Lim, Chien-Kuo Chiu, Benson Hsiung

Abstract—This paper details the utilization of artificial intelligence (AI) in the field of slope stability whereby quick and convenient solutions can be obtained using the developed tool. The AI tool used in this study is the artificial neural network (ANN), while the slope stability analysis methods are the finite element limit analysis methods. The developed tool allows for the prompt prediction of the safety factors of fill slopes and their corresponding probability of failure (depending on the degree of variation of the soil parameters), which can give the practicing engineer a reasonable basis in their decision making. In fact, the successful use of the Extreme Learning Machine (ELM) algorithm shows that slope stability analysis is no longer confined to the conventional methods of modeling, which at times may be tedious and repetitive during the preliminary design stage where the focus is more on cost saving options rather than detailed design. Therefore, similar ANN-based tools can be further developed to assist engineers in this aspect.

Keywords—Landslide, limit analysis, ANN, soil properties.

I. INTRODUCTION

SLOPE stability is a common geotechnical problem that has received attention in the past decades [1]-[4]. The stability problems of natural slopes, fill slopes (such as embankments, earth dams and levees), or cut slopes are commonly encountered in civil engineering projects. Fill slopes in particular often appear in the construction of embankments and highways where soils (fill materials) are placed on an existing layer of foundation [5], [6]. An example of such slopes can be seen in the illustration of Fig. 1.

The very first set of stability charts were produced by Taylor [7], and hence, begun the trend of the use of stability charts as design tool in slope stability problems. It should be noted there are some limitations to chart solutions, and these limitations include accuracy issues that may arise from interpolation and/or manual reading of the charts. In addition, the results of Lim et al. [8] revealed that the slope probability of failure (P_f) is extremely cumbersome to be predicted precisely, if there is more than one soil layer in a slope.

Shahin et al. [9] indicated that ANN has been successfully

used to solve various geotechnical engineering problems such as pile capacity, modeling soil behavior, site characterization, earth retaining structures and others. The techniques are mainly used to estimate some factors that are difficult to be measured directly or accurately. Moreover, compared with the conventional trial-and-error method, they involve a considerably shorter computation time. As highlighted by Silva et al. [10], risk-based analyses are not as well adopted because of the difficulty in performing a probabilistic analysis by rigorous mathematical means. In this paper, we aim to develop an accurate and quick solution to analyze the stability of two-layered undrained clay slopes. At the same time, simple reliability assessments of the slopes will be also provided.

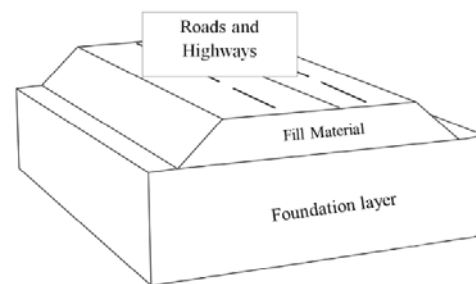

Fig. 1 Example of an embankment slope

II. PREVIOUS STUDIES

A. Slope Stability Investigations

Limit equilibrium method (LEM) is one of the most popular methods to evaluate the stability of slopes [11]. Currently, LEM has been applied to both two dimensional (2D) and three dimensional (3D) slope stability analyses. It is known, however, that in using LEM, the potential slip surface must be assumed before calculating the factor of safety (F) for the slope. Moreover, arbitrary assumptions need to be made regarding forces between two slices. Because of these assumptions, the results are often questioned. In particular, the slip surfaces must be assumed for some cases based on experience or judgment [12], [13].

Finite element method (FEM) is also a popular approach used for slope analyses. Duncan [1] indicated that FEM is a useful tool to calculate stresses, movements, as well as pore pressure and other characteristics of earth masses during construction without previously assuming the potential sliding surface. To estimate the slope stability and obtain its factor of safety by using finite-element analysis, the strength reduction method (SRM) is widely used. However, the failure load is determined subjectively, generally based on observation of the

A. J. Li is with Department of Civil and Construction Engineering, National Taiwan University of Science and Technology, Taipei 106, Taiwan (corresponding author, phone: 886-2-2737-6595; fax: 886-2-2737-6606; e-mail: bou871@gmail.com).

K. Lim, is with Arup, Penang 10250, Malaysia (e-mail: Kelvin.lim@arup.com).

C. K. Chiu is with Department of Civil and Construction Engineering, National Taiwan University of Science and Technology, Taipei 106, Taiwan (e-mail: ckchiu@mail.ntust.edu.tw).

B. Hsiung is with Department of Civil Engineering, National Kaohsiung University of Applied Science, Kaohsiung 807, Taiwan (e-mail: benson@cc.kuas.edu.tw).

slope displacement [14], [15]. In fact, FEM is rarely used to perform slope stability charts, this is because using FEM is not time effective.

Fortunately, attractive finite element upper and lower bound approaches have been developed by Lyamin and Sloan [16], [17] and Krabbenhoft et al. [18]. These techniques can be used to bracket the true stability solutions for geotechnical problems from above and below. In addition, they are suited to assigning many typical failure criteria. The numerical upper and lower bound limit analysis methods will be employed in this study to investigate probability of failure (P_f) for fill slopes.

B. Applications of ANN to Slope Stability

Recently, optimization techniques, such as ANNs and genetic algorithms (GAs), have been applied to many geotechnical investigations, including the evaluation of soil and rock properties [19], [20], anchor and bearing capacity [21], [22], ground movements [23], [24], and slope failures [25], [26]. Among the available AI techniques, ANNs are the most commonly used technique in geotechnical engineering. The techniques are mainly used to estimate factors that are difficult to measure directly or accurately; moreover, compared with the conventional trial-and-error method, they involve a considerably shorter computation time [27]. In recent years, ANNs have been successfully applied to slope stability assessment. The studies of Abdalla et al. [28] and Gelisli et al. [29] demonstrated that ANNs can be used to predict the factors of safety of slopes reasonably. However, only single-layer homogeneous cohesive-frictional soil slopes were investigated in their studies. The solutions for fill slopes based on ANNs do not exist so far. Therefore, this study aims to take advantage of ANNs for fill slope assessments.

III. METHODOLOGY

A. Finite Element Limit Analysis Methods

By using both numerical upper and lower bound limit analysis methods [16]–[18] for slope stability evaluations, Shiau et al. [30] investigated the effects of external loading on undrained slopes. Moreover, Kim et al. [31] and Loukidis et al. [32] proposed sets of stability charts for nonhomogeneous soil slopes and cohesive-frictional soil slopes subjected to pore pressure and seismic loadings, respectively.

To simplify the problem, only 2D cases are considered in this study. The illustration of the slope stability problem investigated herein is shown in Fig. 2. The slope geometry analyzed for the filled slopes with two purely cohesive layered soils can be seen in Fig. 2. It should be noted that the undrained shear strength in Region 1 (c_{u1}) and Region 2 (c_{u2}) are with different values. In this study, for given slope height (H), slope angle (β), and undrained shear strength (c_{u1} and c_{u2}), the optimized solutions of the UB and LB programs can be carried out with respect to the unit weight, γ . Recently, Qian et al. [33] proposed a non-dimensional stability number, N_{2c} , as shown in (1), where F is the slope factor of safety. It should be noted that the magnitude of F obtained by (1) is generally different from that by the conventional LEM due to their different definitions.

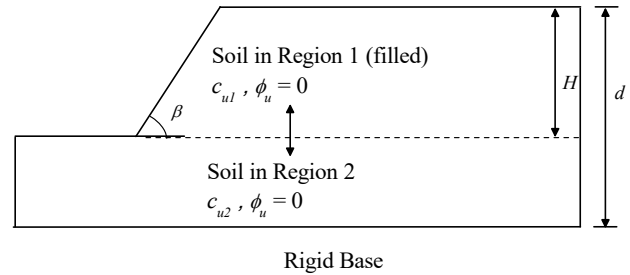

Fig. 2 Problem configuration for cohesive material filled on purely cohesive soil

$$N_{2c} = \frac{c_{u1}}{\gamma HF} \quad (1)$$

For the upper bound (UB) theorem, the power dissipated by any kinematically admissible velocity field can be equated to the power dissipated by the external loads to give a rigorous UB on the true limit load [15]. The lower bound (LB) theorem states that the admissible stress field must fulfill equilibrium, the stress boundary condition, and yield conditions [14]. For 2D limit analysis modeling, the mesh generation must follow two important guidelines: (1) the overall mesh dimensions are adequate to contain the computed stress field (LB) or velocity/plastic field (UB); and (2) there is an adequate concentration of elements within critical regions. The final finite-element mesh arrangements (both UB and LB) were selected only after considerable refinements were made. The typical finite-element mesh for the UB and LB limit analysis is displayed in Fig. 3

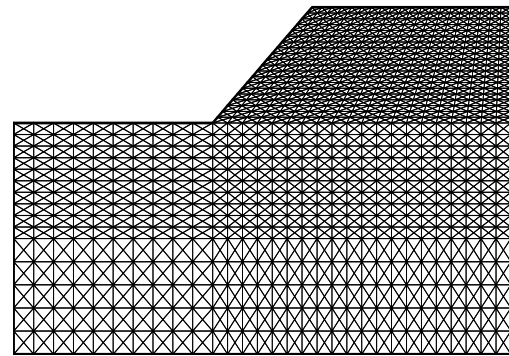

Fig. 3 Problem configuration for cohesive material filled on purely cohesive soil

B. ANN

Since ANN has been proven to be a universal approximator, the linear combinations of the nonlinear neurons and weights, after proper training or selections, can approximate any linear or nonlinear functions. As a result, a single hidden layer feed forward neural network is chosen herein, whereby the inputs of the trained ANN are continuously mapped to the outputs in a differentiable manner.

Fig. 4 illustrates a single-hidden layer feed forward neural network, which will serve as a basic framework for our study. Then in order to expedite the training process, ELM [34] is

used, which is an improvement in terms of speed over the commonly used gradient-based back propagation (BP) algorithm. Basically, the BP algorithm compares the degree of error between ANN output and the desired output and slowly minimizes the error, and therefore, is time consuming.

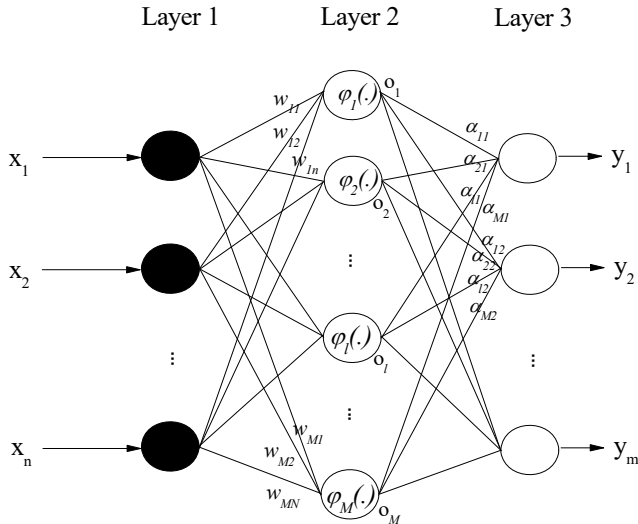

Fig. 4 Single-hidden layer neural network

However, the use of the ELM training algorithm facilitates the random assignment of the weights of the ANN and the consideration of the ANN as a linear system. However, the main feature of the ELM algorithm is its batch learning capability; it trains the ANN in a single global optimization operation, and therefore, the learning speed of the ELM can be considerably faster than the BP. The input data vector $x(k)$ and the output data vector $y(k)$ can be expressed as follows:

$$x(k) = [x_1(k) \quad x_2(k) \quad \dots \quad x_n(k)]^T \quad (2)$$

$$y(k) = [y_1(k) \quad y_2(k) \quad \dots \quad y_n(k)]^T \quad (3)$$

and the i th output of the neural network, $y_i(k)$ can be expressed as:

$$y_i(k) = \sum_{j=1}^M \alpha_{ji} o_j = \sum_{j=1}^M \alpha_{ji} \phi(w_j^T x(k)) = \xi^T(k) \alpha_i \quad (4)$$

Suppose we have N training input vectors $x(1), x(2), \dots, x(N)$ and N desired output data vectors $y_d(1), y_d(2), \dots, y_d(N)$ for training the ANN, as in Fig. 1. The following derivations can be easily obtained:

$$\begin{bmatrix} y^T(1) \\ \vdots \\ y^T(N) \end{bmatrix} = \begin{bmatrix} \xi^T(1) \\ \vdots \\ \xi^T(N) \end{bmatrix} \alpha = G \alpha \quad (5)$$

with

$$G = \begin{bmatrix} \phi(w_1^T x(1)) & \dots & \phi(w_M^T x(1)) \\ \vdots & \dots & \vdots \\ \phi(w_1^T x(N)) & \dots & \phi(w_M^T x(N)) \end{bmatrix} \quad (6)$$

The output weight matrix, G , of the ANN can be computed in a single iteration, where

$$\alpha = (G^T G)^{-1} G^T Y_d \quad (7)$$

and

$$Y_d = \begin{bmatrix} y_d^T(1) \\ \vdots \\ y_d^T(N) \end{bmatrix} \quad (8)$$

IV. RESULTS AND DISCUSSIONS

Based on the developed tool, a couple of parametric studies have been done to show the benefits and also the efficiency of the tool. The slope parameters of the first parametric study are as follows: c_{u1}/c_{u2} ratio = 4, $c_{u1} = 50$ kN/m², a unit weight $\gamma = 18$ kN/m³, and a depth factor $d/H = 2$. Further to that, varying slope heights and slope angles are used to demonstrate the convenience of the tool. Additionally, the coefficients of variation (COVs) of the undrained shear strength of soil are also varied. The other parameters used can be seen in Table I.

TABLE I
PARAMETRIC STUDY 1 – SLOPE PARAMETERS

Case #	Slope angle (°)	Slope Height (m)	COV of c_{u1}	COV of c_{u2}
1	15	3	0.1	0.2
2	30	4	0.2	0.1
3	45	5	0.1	0.3
4	60	6	0.2	0.3
5	75	7	0.3	0.3

The first thing we can observe from Table II is that the stability numbers produced by our developed tool are very similar to the targeted stability numbers (targeted stability numbers are obtained from the numerical analysis). Based on the stability numbers and also the slope parameters, the factors of safety for the respective slope heights are obtained. The factors of safety can be obtained as $F = NH\gamma/c_{u1}$. As expected, the results show that the factor of safety decreases as the slope height increases. In fact, the advantage of the tool allows for the probability of failure to be obtained in tandem with the factor of safety. For instance, under column 5 of Table II, the probability of failure can be seen to increase as the factor of safety decreases. In this case, the probability of failure is also affected by the coefficient of variation. For example, while the factor of safety for the 3rd case is $F = 1.17$, the slope is with a probability of failure of approximately 0.14. In a slope design, factor of safety less than unity is undesirable. This is clearly reflected in case 4 and case 5 where the slopes are considered as unsafe.

TABLE II
 PARAMETRIC STUDY 1 - RESULTS

Case #	Stability number (numerical analyses)	Stability number (ANN)	Factor of safety (ANN)	Probability of failure (Pf)
1	0.388	0.388	2.39	4.7E-07
2	0.455	0.455	1.53	3.9E-04
3	0.474	0.474	1.17	0.14
4	0.488	0.488	0.95	0.62
5	0.519	0.5185	0.77	0.91

TABLE III
 PARAMETRIC STUDY 2 – SLOPE PARAMETERS

Case #	Slope angle (°)	Slope Height (m)	c_{u1}/c_{u2} ratio	d/H	COV of c_{u1}	COV of c_{u2}
1	15	5	4	2	0.1	0.1
2	30	4	3	3	0.2	0.2
3	45	4	3	3	0.3	0.3
4	60	5	2	3	0.3	0.3
5	75	5	2	3	0.1	0.1

TABLE IV
 PARAMETRIC STUDY 1 - RESULTS

Case #	Stability number (ANN)	Factor of safety (ANN)	Probability of failure (Pf)
1	0.388	1.15	0.04
2	0.452	1.2	0.12
3	0.461	1.2	0.23
4	0.342	1.6	0.06
5	0.349	1.6	1.1E-05

To further investigate the consequences of the coefficient of variation and also the commonly used range of factor of safety, the second parametric study is performed. In this parametric study (Table III), the slope parameters such as c_{u1}/c_{u2} ratio, c_{u1} , and depth factor d/H are all varied except for the unit weight where we use $\gamma = 18 \text{ kN/m}^3$. The results, which were produced in a quick 2-3 seconds can be seen in Table IV. From the table, it can be seen that probability of failure may paint a clearer picture in addition to the conventional factor of safety. For instance, many would think that a factor of safety of approximately 1.2 is barely sufficient for a safe slope design. However, it may be hard to quantify the factor of safety without defining it in terms of probability of failure. Therefore, using the developed tool, the use of factor of safety can now be more relevant in slope design. For example, the results show that a slope with a factor of safety of 1.2 is theoretically very risky as there may be a two in 10 chance that the slope may fail. In fact, that risk may be further reduced if a more thorough soil investigation is done such as performing different soil strength test or more boreholes. As can be seen from Table IV, the risk is slightly lower if the coefficient of variation is lower (comparing case 1, case 2 and case 3). Furthermore, a comparison between case 4 and case 5, where the factor of safety is about the same, shows that soil with high uncertainties may lead to a risky slope. Thus, from the above parametric studies, a few conclusions can be made. This newly developed tool introduces a quick and convenient way to assess slope stability while also offering an insight to the relevance of factor of safety in slope designs. Additionally, the influence of uncertainties in soil

properties was also demonstrated. Particularly, in today's industry where clients are focused on cost reduction whereby quick justification is required to convince the clients in investing in a proper and thorough soil investigation.

V. CONCLUSION

This study adopts the techniques, ANN to develop a fast evaluation tool for fill slope stability analyses. The training data are obtained based on the finite element upper and lower bound limit analysis solutions. The developed tool can provide prompt fill slope stability estimations and its probability of failure. It is very useful for practicing engineers, particularly for decision making

REFERENCES

- [1] J. M. Duncan, "State of the art: Limit equilibrium and finite-element analysis of slopes," *J. Geotech. Engrg.*, vol. 122, no. 7, pp. 577–596, Jul 1996.
- [2] M. Chang, "A 3D slope stability analysis method assuming parallel lines of intersection and differential straining of block contacts," *Can. Geotech. J.*, vol. 39, no. 4, pp. 799–811, Aug 2002.
- [3] R. Baker, R. Shukha, V. Operstein, and S. Frydman, "Stability charts for pseudo-static slope stability analysis," *Soil. Dyn. Earthquake Eng.*, vol. 26, no. 9, pp. 813–823, Sep 2006.
- [4] K. Lim, A. V. Lyamin, M. J. Cassidy, and A. J. Li, "Three-dimensional slope stability charts for frictional fill materials placed on purely cohesive clay," *Int. J. Geomech.*, vol. 16, no. 2, Apr 2016.
- [5] B. Indraratna, A. Balasubramaniam, and S. Balachandran, "Performance of test embankment constructed to failure on soft marine clay," *J. Geotech. Engrg.*, vol. 118, no. 1, pp. 12–33, Jan 1992.
- [6] A. S. Al-Homoud, A. B. Tal, and S.A. Taqieddin, "A comparative study of slope stability methods and mitigative design of a highway embankment landslide with a potential for deep seated sliding," *Eng. Geology*, vol. 47, no. 1-2, pp. 157–173, Aug 1997.
- [7] D. W. Taylor, "Stability of earth slopes," *J. Boston Soc. Civ. Eng.*, vol. 24, pp. 197–246, 1937.
- [8] K. Lim, M. J. Cassidy, A. J. Li, and A. V. Lyamin, "Mean parametric monte carlo study of fill slopes," *Int. J. Geomech.*, ([http://dx.doi.org/10.1061/\(ASCE\)GM.1943-5622.0000812](http://dx.doi.org/10.1061/(ASCE)GM.1943-5622.0000812)).
- [9] M. A. Shahin, M. B. Jaksa, and H. R. Maier, "Artificial neural network applications in geotechnical engineering," *Australian Geomechanics*, vol. 36, no. 1, pp. 49–62, Mar 2001.
- [10] F. Silva, T.W. Lambe, and W.A. Marr, "Probability and risk of slope failure," *J. Geotech. Geoenviron. Eng.*, vol. 134, no. 12, pp. 1691–1699, Dec 2008.
- [11] A. J. Li, M. J. Cassidy, Y. Wang, R. S. Merifield, and A. V. Lyamin, "Parametric Monte Carlo studies of rock slopes based on the Hoek–Brown failure criterion," *Comput. Geotech.*, vol. 45, pp. 11–18, Sep 2012.
- [12] K. J. Shou, and C. F. Wang, "Analysis of the Chiufengershan landslide triggered by the 1999 Chi-Chi earthquake in Taiwan," *Eng. Geol.*, vol. 68, no. 3–4, pp. 237–250, Mar 2003.
- [13] K. Lim, A. J. Li, A. Schmid, and A. V. Lyamin "Slope-stability assessments using finite-element limit analysis methods," *Int. J. Geomech.*, vol. 17, no. 2, Feb 2017.
- [14] D. Griffiths, and R. Marquez, "Three-dimensional slope stability analysis by elastoplastic finite elements," *Geotechnique*, vol. 57, no. 6, pp. 537–546, Aug 2007.
- [15] M. T. Manzari, and M. A. Nour, "Significance of soil dilatancy in slope stability analysis," *J. Geotech. Geoenviron. Eng.*, vol. 26, no. 1, pp. 75–80, Jan 2000.
- [16] A. V. Lyamin, and S. W. Sloan, "Lower bound limit analysis using non-linear programming," *Int. J. Numer. Methods. Eng.*, vol. 55, no. 5, pp. 573–611, Jul 2002.
- [17] A. V. Lyamin, and S. W. Sloan, "Upper bound limit analysis using linear finite elements and non-linear programming," *Int. J. Numer. Anal. Methods Geomech.*, vol. 26, no. 2, pp. 181–216, Feb 2002.
- [18] K. Krabbenhoft, A. V. Lyamin, M. Hjiaj, and S. W. Sloan, "A new discontinuous upper bound limit analysis formulation," *Int. J. Numer. Methods. Eng.*, vol. 63, no. 7, pp. 1069–1088, Jun 2005.

- [19] S. J. Lee, S. R. Lee, and Y. S. Kim, "An approach to estimate unsaturated shear strength using artificial neural network and hyperbolic formulation," *Comput. Geotech.*, vol. 30, no. 6, pp. 489–503, Sep 2003.
- [20] H. Sonmez, C. Gokceoglu, H. A. Nefeslioglu, and A. Kayabasi, "Estimation of rock modulus: for intact rocks with an artificial neural network and for rock masses with a new empirical equation," *Int. J. Rock Mech. Min. Sci.*, vol. 43, no. 2, pp. 224–235, Feb 2006.
- [21] M. A. Shahin, and M. B. Jaksa, "Neural network prediction of pullout capacity of marquee ground anchors," *Comput. Geotech.*, vol. 32, no. 3, pp. 153–163, Apr 2005.
- [22] Y. L. Kuo, M. B. Jaksa, A. V. Lyamin, and W. S. Kasswa, "ANN-based model for predicting the bearing capacity of strip footing on multi-layered cohesive soil," *Comput. Geotech.*, vol. 36, no. 3, pp. 503–516, Apr 2009.
- [23] R. Boubou, F. Emeriault, and R. Kastner, "Artificial neural network application for the prediction of ground surface movements induced by shield tunnelling," *Can. Geotech. J.*, vol. 47, no. 11, pp. 1214–1233, Nov 2010.
- [24] G. T. C. Kung, E. C. L. Hiao, M. Schuster, and C. H. Huang, "A neural network approach to estimating deflection of diaphragm walls caused by excavation in clays," *Comput. Geotech.*, vol. 34 no. 5, pp. 385–396, Sep 2007.
- [25] S. E. Cho, "Probabilistic stability analyses of slopes using the ANN-based response surface," *Comput. Geotech.*, vol. 36, no. 5, pp. 787–797, Jun 2009.
- [26] A. J. Li, S. Khoo, A. V. Lyamin, Y. Wang, "Rock slope stability analyses using extreme learning neural network and terminal steepest descent algorithm," *Automation in Construction*, vol. 65, pp.42–50, May 2016.
- [27] M. Sari, "The stochastic assessment of strength and deformability characteristics for a pyroclastic rock mass," *Int. J. Rock Mech. Min. Sci.*, vol. 46, no. 3, pp. 613–626, Apr 2009.
- [28] J. A. Abdalla, M. F. Attom, and R. Hawileh, "Prediction of minimum factor of safety against slope failure in clayey soils using artificial neural network," *Environmental Earth Sciences*, vol. 73, no. 9, pp. 5463-5477, May 2015.
- [29] K. Gelisli, T. Kaya, and A. E. Babacan, "Assessing the factor of safety using an artificial neural network: case studies on landslides in Giresun, Turkey," *Environmental Earth Sciences*, vol. 73, no. 12, pp. 8639-8646, Jun 2015.
- [30] J. Shiau, R. S. Merifield, A. V. Lyamin, and S. W. Sloan "Undrained stability of footings on slopes," *Int. J. Geomech.*, vol. 11, no. 5, pp. 381–290, Oct 2011.
- [31] J. Kim, R. Salgado, and H. Yu "Limit analysis of soil slopes subjected to pore-water pressures." *J. Geotech. Geoenviron. Eng.*, vol. 125, no. 1, pp. 49–58, Jan 1999.
- [32] D. Loukidis, P. Bandini, and R. Salgado. "Stability of seismically loaded slopes using limit analysis," *Geotechnique*, vol. 53, no. 5, pp. 463–480, Jun 2003.
- [33] Z. Qian, A. J. Li, R. S. Merifield, and A. V. Lyamin "Slope stability charts for two-layered purely cohesive soils based on finite-element limit analysis methods," *Int. J. Geomech.*, vol. 15, no. 3, Jun 2015.
- [34] G. B. Huang, L. Chen, and C. Siew "Universal approximation using incremental constructive feedforward networks with random hidden nodes," *IEEE Transactions on Neural Networks*, vol. 17, no. 4, pp. 879–892, Jul 2006.