

Crashworthiness Optimization of an Automotive Front Bumper in Composite Material

S. Boria

Abstract—In the last years, the crashworthiness of an automotive body structure can be improved, since the beginning of the design stage, thanks to the development of specific optimization tools. It is well known how the finite element codes can help the designer to investigate the crashing performance of structures under dynamic impact. Therefore, by coupling nonlinear mathematical programming procedure and statistical techniques with FE simulations, it is possible to optimize the design with reduced number of analytical evaluations. In engineering applications, many optimization methods which are based on statistical techniques and utilize estimated models, called meta-models, are quickly spreading. A meta-model is an approximation of a detailed simulation model based on a dataset of input, identified by the design of experiments (DOE); the number of simulations needed to build it depends on the number of variables. Among the various types of meta-modeling techniques, Kriging method seems to be excellent in accuracy, robustness and efficiency compared to other ones when applied to crashworthiness optimization. Therefore the application of such meta-model was used in this work, in order to improve the structural optimization of a bumper for a racing car in composite material subjected to frontal impact. The specific energy absorption represents the objective function to maximize and the geometrical parameters subjected to some design constraints are the design variables. LS-DYNA codes were interfaced with LS-OPT tool in order to find the optimized solution, through the use of a domain reduction strategy. With the use of the Kriging meta-model the crashworthiness characteristic of the composite bumper was improved.

Keywords—Composite material, crashworthiness, finite element analysis, optimization.

I. INTRODUCTION

IN engineering, structural design problems usually require real experiments or numerical simulation to evaluate the performances of the designed components. Given the high costs of the real tests, it is becoming common practice to reduce them by coupling finite element simulations with mathematical procedures and statistical techniques, in order to optimize the structural component. An optimization problem is usually defined by objective and constraint functions and aims to find a solution which, at the same time, does not violate any constraint and optimizes the objective function. For many real world problems, however, a single simulation can require thousands or even millions of evaluations and this results in an analysis that is impossible to handle [1]. One way of getting around this difficulty is to substitute the computationally expensive direct optimization with an iterative process able to create, optimize and update a

surrogate model (or meta-model) that, being faster to run, can be used to achieve many more evaluations during the optimization procedure. Constructing a surrogate means to find an approximation $\bar{f}(x)$ of the function $f(x)$, living in some black box, through the evaluation of a set of samples $(x^{(i)}, y^{(i)})$, for $i = 1, \dots, n$. The black box hides the physics that converts the input vector x into the scalar output y and it can stand for either a physical or computer experiment. The construction of a surrogate model comprises three major phases that can be interleaved iteratively: selection of the sample points and choice of the modeling approach, parameter estimation and testing the surrogate accuracy. In the recent times, these approximation models gained popularity due to the fact that they are able to carry out an optimization procedure without any gradient or sensitivity knowledge. Therefore, they turn out to be very flexible and adapt many applications, included the ones which are characterized by heavy noisiness, strong nonlinearities, several local extrema and discontinuities, such as crashworthiness.

Crashworthiness is generally defined as the ability of a structure to resist the effects of an impact with another object. In automotive industry, it aims to ensure the vehicle structural integrity and its ability to absorb crash energy with minimal diminution of survival space. In general, the best knowledge of the safety features of a vehicle is stored by the car manufacturers. Since their products have to respect strict regulations to be brought to the market, hundreds of tests are performed on each of the developed models. Since automotive physical experiments are characterized by prohibitive times and costs, driven by the challenge of coupling vehicle safety and sustainability (low fuel consumption and CO² emission reduction), the automotive industry has to put substantial effort into the project and design phase of its products. Crashworthiness design is an evolving discipline that combines vehicle crash simulation and design synthesis. The main objective is to assure vehicles' occupant safety as well as reduce manufacturing and material costs. In order to generate designs that perform well in terms of energy absorption while demonstrating fidelity for safety regulations, the method of trial-and-error (i.e. where the shape design is modified and simulated iteratively until the target performances are satisfied) is commonly used in engineering. Using this approach, however, the resulting design is frequently not optimal and time costs increase due to the need for redesign of the components. Therefore, numerical simulations using finite element software and optimization techniques combined with statistical tools have to be used to design better solutions reducing analytical evaluations [2]. The methods related to

S. B. is with the School of Science and Technology, University of Camerino, Camerino, 62032 Italy (phone: +390737402503; e-mail: simonetta.boria@unicam.it).

meta-models and their applications in crashworthiness optimization have been extensively investigated over the years [3]-[7]. Among the various types of meta-modeling techniques used for crashworthiness optimization, Kriging method seems to be the best one. For this reason, in this study such meta-model was used in order to improve the crashworthiness effects of a bumper of a racing car in composite material subjected to frontal impact. The bumper systems, in fact, play an important role in the energy management of vehicles during accidents. The objective function is the maximization of the specific energy absorption and the design variables are geometrical parameters subjected to some design constraints. The optimized solution was obtained with the application of LS-OPT tool using LS-DYNA as solver and a domain reduction strategy.

II. KRIGING METAMODEL

In crashworthiness optimization, direct coupling method may be inefficient and sometimes impossible since iterative non-linear FEA during optimization usually require enormous computational efforts and take the high risk of premature simulation failure prior to a proper convergence. As a result, surrogate models or metamodels are more often used as an alternative for formulating the design criteria in terms of an explicit function of design variables in advance of optimization, which has proven an effective and sometimes a unique approach [8]-[10]. In this study Kriging metamodel was applied using Space Filling DOE; approximated functions were created using seven simulation points and fifteen iterations with sequential domain reduction strategy [11].

Kriging was first used in geology and named by Matheron [12] after Danie G. Krige, the South African mining engineer who first developed the method. It became well known in the engineering design field after the works by Sacks et al. [13] and Jones et al. [14]. This method is particularly important in surrogate based optimization and attracted the interest of many researchers due to the great quantity of information that makes available, e.g. the estimate of the potential error in the approximation, the benefits of which are described later [15]-[19]. Starting from a set of sample data $X = \{x^{(1)}, x^{(2)}, \dots, x^{(n)}\}$ with observed responses $y = \{y^{(1)}, y^{(2)}, \dots, y^{(n)}\}$, the aim is to predict the objective function value at the location x . Below, a brief description of the Kriging surrogate technique is presented, considering its two main phases: the model construction and the response value prediction.

A. Model Construction

One of the main features of the Kriging model is that it can demonstrate interpolative as well as regressive characteristics. The model characterization that follows is given under the assumption of the interpolative case. The detailed description of the regressing Kriging definition was given by Forrester et al. [1]. At first, let the training data be seen as results of a stochastic process, which is described with use of a set of random vectors of the following form

$$Y(x) = \begin{pmatrix} Y(x^{(1)}) \\ \vdots \\ Y(x^{(n)}) \end{pmatrix} \quad (1)$$

with mean $\mathbf{1}\mu$, where $\mathbf{1}$ is an $n \times 1$ column vector of ones. Moreover, let the correlation between each couple of random variables be described using a basis function expression

$$\text{cor}[Y(x^{(i)}), Y(x^{(l)})] = e^{-\sum_{j=1}^k \theta_j |x_j^{(i)} - x_j^{(l)}|^{p_j}} \quad (2)$$

The θ vector allows the width of the basis function to differ from variable to variable, while p , varying for each dimension, controls the smoothness of the approximation in the proximity of the given sample points. Fig. 1 shows how the choice of these two parameters affects the correlation between variables.

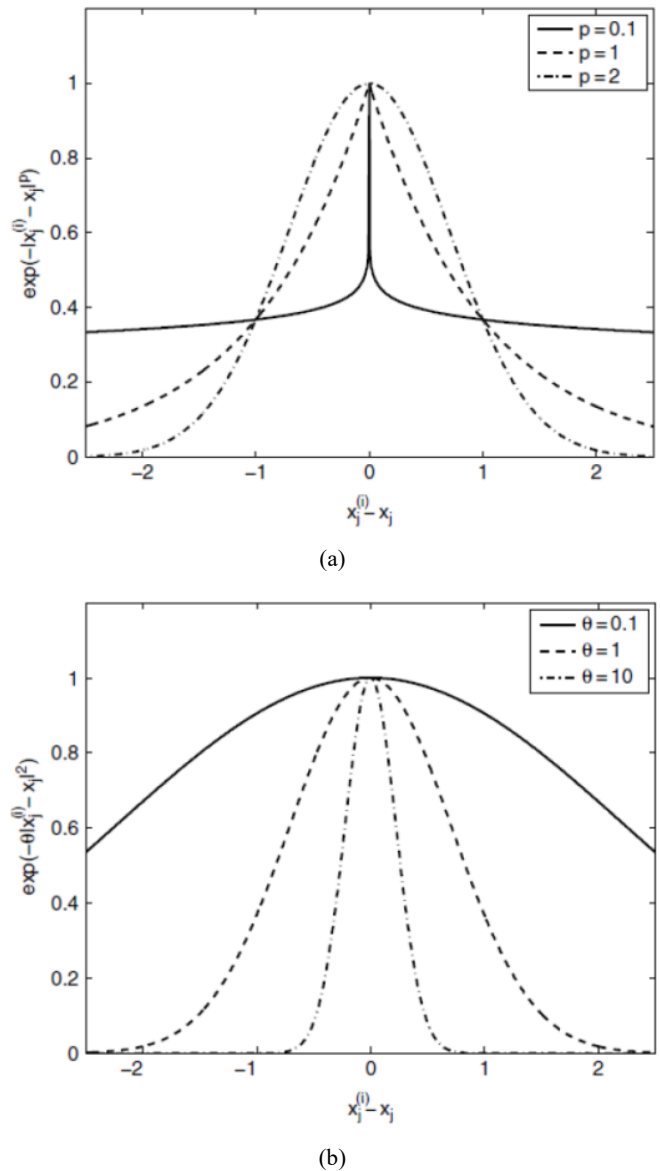

Fig. 1 Correlation with varying p (a) and θ (b)

From equation (2), it is possible to construct the correlation matrix of all the observed data as

$$\Psi = \begin{pmatrix} \text{cor}[Y(x^{(1)}), Y(x^{(1)})] & \dots & \text{cor}[Y(x^{(i)}), Y(x^{(n)})] \\ \vdots & \ddots & \vdots \\ \text{cor}[Y(x^{(n)}), Y(x^{(1)})] & \dots & \text{cor}[Y(x^{(n)}), Y(x^{(n)})] \end{pmatrix} \quad (3)$$

together with the covariance matrix

$$\text{Cov}[\mathbf{Y}, \mathbf{Y}] = \sigma^2 \Psi \quad (4)$$

It can be observed that the correlations depend on the absolute distance between the sample points and on the parameters p_j and θ_j that have to be estimated. One way to choose θ and p is by means of the maximization of the likelihood of the predicted data \mathbf{y} . Since the model interpolates the data, the likelihood function is defined as

$$L(Y^{(1)}, \dots, Y^{(n)} | \mu, \sigma) = \frac{1}{(2\pi\sigma^2)^{n/2}} e^{-\frac{\sum (Y^{(i)} - \mu)^2}{2\sigma^2}} \quad (5)$$

which can be expressed in terms of the sample data as

$$L = \frac{1}{(2\pi\sigma^2)^{n/2} |\Psi|^{1/2}} e^{-\frac{(y-1\mu)^T \Psi^{-1} (y-1\mu)}{2\sigma^2}} \quad (6)$$

Now, to simplify the maximization of the likelihood, the logarithm of the previous quantity can be considered

$$\ln(L) = -\frac{n}{2} \ln(2\pi) - \frac{n}{2} \ln(\sigma^2) - \frac{1}{2} \ln |\Psi| - \frac{(y-1\mu)^T \Psi^{-1} (y-1\mu)}{2\sigma^2} \quad (7)$$

Finally, differentiating equation (7) and setting the derivatives to zero, the maximum likelihood estimates (MLEs) for μ and σ^2 are obtained as

$$\bar{\mu} = \frac{\mathbf{1}^T \Psi^{-1} \mathbf{y}}{\mathbf{1}^T \Psi^{-1} \mathbf{1}} \quad (8)$$

$$\bar{\sigma}^2 = \frac{(y-1\bar{\mu})^T \Psi^{-1} (y-1\bar{\mu})}{n} \quad (9)$$

If (8) and (9) are then substituted into (7) and the constant terms removed, one can get the concentrated ln-likelihood function

$$\ln(L) \approx -\frac{n}{2} \ln(\bar{\sigma}^2) - \frac{1}{2} \ln |\Psi| \quad (10)$$

whose value depends on the unknown parameters θ and p , which can be found by maximizing equation (10). Since Equation (10) cannot be differentiated, a numerical optimization technique such as a genetic algorithm or simulated annealing has to be used.

B. Prediction

The model correlation can be now used to predict new values based on the observed data. Let \mathbf{y} be the output vector and \bar{y} a prediction related to a new input x . It is also convenient to define the vector $\mathbf{w} = \{\mathbf{y}^T, \bar{y}\}^T$. Moreover, let ψ be the vector of correlations between the observed data and the new prediction defined as

$$\psi = \begin{pmatrix} \text{cor}[Y(x^{(1)}), Y(x)] \\ \vdots \\ \text{cor}[Y(x^{(n)}), Y(x)] \end{pmatrix} = \begin{pmatrix} \psi^{(1)} \\ \vdots \\ \psi^{(n)} \end{pmatrix} \quad (11)$$

Given the augmented correlation matrix

$$\bar{\Psi} = \begin{pmatrix} \Psi & \psi \\ \psi^T & 1 \end{pmatrix} \quad (12)$$

The ln-likelihood of the augmented data is defined as

$$\ln(L) = -\frac{n}{2} \ln(2\pi) - \frac{n}{2} \ln(\bar{\sigma}^2) - \frac{1}{2} \ln |\bar{\Psi}| - \frac{(\mathbf{w}-1\bar{\mu})^T \bar{\Psi}^{-1} (\mathbf{w}-1\bar{\mu})}{2\bar{\sigma}^2} \quad (13)$$

where only the last term of this depends on \bar{y} . Finally, by the substitution of the expressions for \mathbf{w} and $\bar{\Psi}$ in (13) and the maximization of the last term, after few algebraic computations, the MLE for \bar{y} is obtained as

$$\bar{y}(x) = \bar{\mu} + \psi^T \Psi^{-1} (y-1\bar{\mu}) \quad (14)$$

From (14) it can be noted that constructing the model in this way guarantees that the prediction would go through all the data points (i.e. the data are interpolated). In fact, computing the value of the prediction \bar{y} on a training point, one would obtain $\bar{y}(x^{(i)}) = y^{(i)}$. Moreover, the most important benefit of Kriging is the provision of an estimated error in its predictions. The estimated mean squared error for a Kriging model has been derived by Sacks et al. [20] and it takes the following form

$$\bar{s}^2(x) = \bar{\sigma}^2 \left[1 - \psi^T \Psi^{-1} \psi + \frac{1 - \mathbf{1}^T \Psi^{-1} \psi}{\mathbf{1}^T \Psi^{-1} \mathbf{1}} \right] \quad (15)$$

The error estimate is one of the major advantages of the Kriging surrogate model. Indeed, this information can be used to further explore the areas of the domain characterized by a very low accuracy of the approximation model.

III. BUMPER SUBSYSTEM OPTIMIZATION STUDY

To illustrate the methodology described in the section above, an optimization study on an automotive CAD bumper system for a race car was performed.

The bumper geometry was taken from an automotive design practice with a mesh density that is both acceptable for the predictions of interest and also feasible in terms of computational effort. The geometry consists of a cross-section

made of a one chamber that represents the transverse bumper and two longitudinal crash boxes (Fig. 2). Given the symmetry of the system respect to y-axis, only half structure was modelled constraining the right degrees of freedom in the reflection plane. Moreover the right end of the longitudinal crash box is rigidly fixed to the frame.

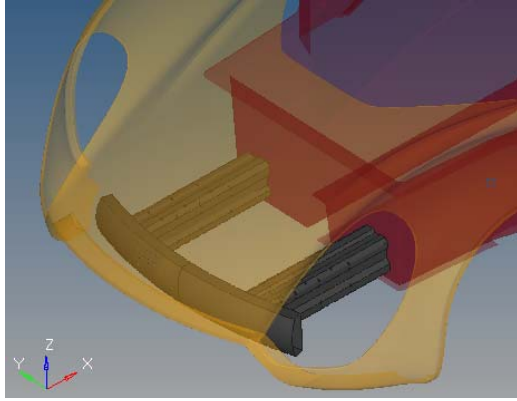

Fig. 2 CAD assembly of the bumper system

As regards the initial condition, instead of IIHS low velocity impact [21], Allianz crash repair test and the impact to pole test [22], a full width front impact against a flat rigid barrier at a speed of 56 km/h was used. In such case, in fact, the bumper system, designed for a race car, must be able to absorb all the kinetic energy during a frontal collision.

From the literature [21], a cross section profile for the bumper with a series of internal hinges seems to be the best one thanks to a progressive and controlled deformation. Therefore, such modified configuration was taken into account together with the original one.

A. Optimization Definition

The optimization process was conducted through three different approaches. Firstly, a change into the beam curvature was analyzed. Secondly, an optimized cross section of the transverse beam was identified and finally, the best configuration was used for an iterative model in LS-OPT (Fig. 3) using the Kriging metamodel.

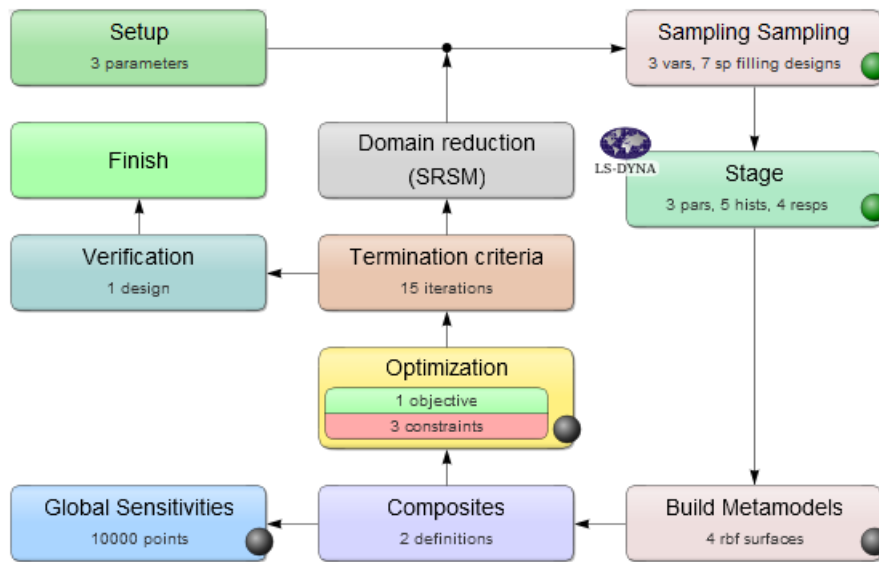

Fig. 3 Iterative model in LS-OPT

B. Beam Curvature Optimization

At first, beam curvature optimization was conducted. In particular the modified profile was tested into three different cases: straight, medium radius and maximum one (Fig. 4).

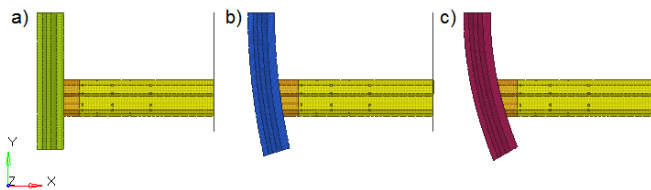

Fig. 4 Beam curvature cases: (a) straight, (b) medium radius, (c) maximum radius

Fig. 5 shows the force trends vs. displacement for the three configurations. Moreover, in Table I the respective values of maximum and average deceleration, maximum stroke and SEA were compared.

TABLE I
 CRASH CHARACTERISTICS FOR THE THREE CONFIGURATIONS

Configuration	Max deceleration (g)	Average deceleration (g)	Max stroke (mm)	SEA (kJ/kg)
Straight	108.77	29.89	340.87	15.50
Medium radius	57.74	17.10	526.75	15.23
Maximum radius	65.36	16.69	487.26	15.09

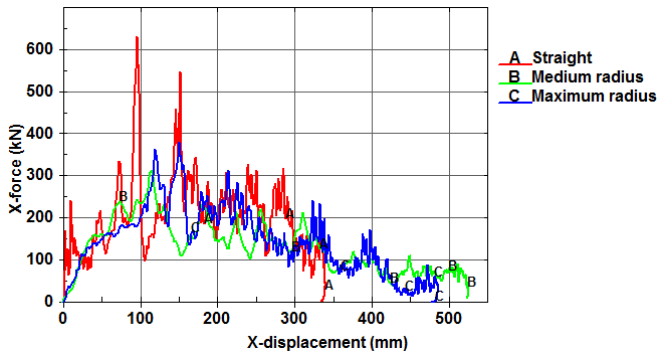
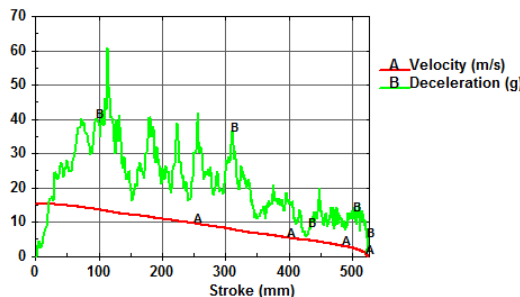

Fig. 5 Force vs. Displacement for the three beam curvatures

Even if the straight configuration reaches a value of SEA greater than the others, the best behavior seems to be reached by the medium radius. From Fig. 5 it is in fact evident how, unlike other cases, the first configuration generates a sequence of high peak loads due to the contact with a larger area since the beginning of impact and involves only a small portion of the longitudinal crash box in the absorption. Fig. 6 shows the diagrams of velocity and deceleration versus stroke for the beam with the medium curvature and also the final deformation of the longitudinal crash box at the impact end. In terms of deformation trend, deceleration values and specific energy absorption the medium radius has the best data and therefore, for the next optimization procedure, the bumper with the medium curvature will be considered varying cross section.



(a)



(b)

Fig. 6 Results for medium radius: (a) velocity and deceleration vs. stroke, (b) final deformation of the longitudinal crash box

C. Section Profile Optimization

Another analyzed change was the profile, varying the cross section of the transverse beam. The modified configuration (Fig. 7 (b)) was compared with the basic CAD model (Fig. 7) in order to identify the best configuration to adopt in terms of section.

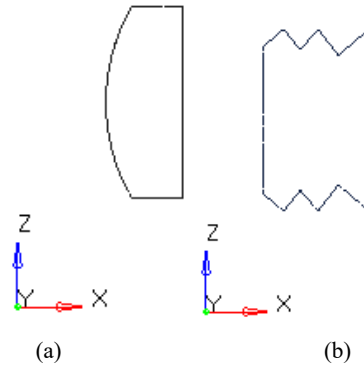

Fig. 7 Profile geometries taken into account: (a) basic and (b) modified

Fig. 8 shows the force trends vs. displacement for both configurations. Moreover, in Table II the respective values of maximum and average deceleration, maximum stroke and specific energy absorption (SEA) were compared.

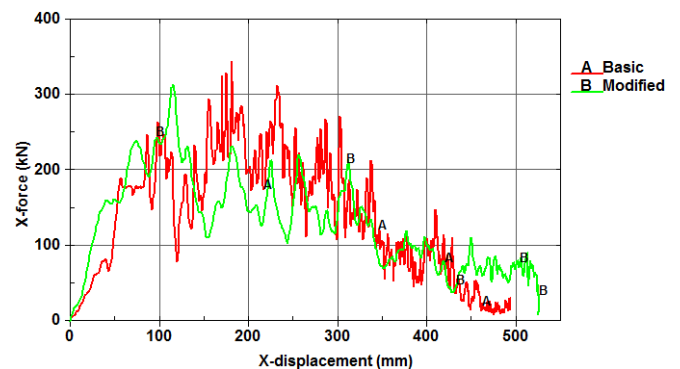

Fig. 8 Force vs. Displacement for both section profiles

TABLE II
 CRASH CHARACTERISTICS FOR BOTH CONFIGURATIONS

Configuration	Max deceleration (g)	Average deceleration (g)	Max stroke (mm)	SEA (kJ/kg)
Basic	63.51	17.23	493.01	17.35
Modified	52.74	17.10	526.75	15.23

As mentioned in previous research [21], the modified profile, with a series of hinges, is able to reduce the peak value and guarantee a more stable and progressive deformation, even if it tends to weigh more than the basic profile. Therefore from the point of view of SEA the basic configuration seems to be more competitive than the other one.

D. Beam Curvature Optimization

Nowadays, with the increasing awareness of the environmental footprint of the vehicle, mass reduction of the

different vehicle subcomponents is mandatory. Meanwhile, a high level of energy absorption must be guaranteed maintaining a deformation level as close as possible to an ideal absorber, without high peaks of deceleration. Therefore, the goal of the optimization process is to obtain an optimized bumper profile in terms of SEA, while satisfying a set of design constraints [23].

In order to optimize the bumper, three parameters were considered that correspond to the shell thickness values of the three parts (red, green and blue) in which the bumper subsystem was divided (Fig. 9). The parameter ranges and the nominal values are represented in Table III. From previous numerical simulations, it was noted that the subdivision, in terms of shell thickness, of the longitudinal crash box into two parts is able to guarantee a reduction of the load peak and the introduction of some alternated holes allows to obtain a progressive and controlled deformation during crushing. Therefore, the mathematical model for the structural optimization is as:

$$\begin{aligned} & \max SEA(t1, t2, t3) \\ & \text{subject to } \begin{cases} \text{Max_acceleration} < 80 \text{m/s}^2 \\ \text{Average_acceleration} < 25 \text{m/s}^2 \\ \text{Max_stroke} < 600 \text{ mm} \end{cases} \end{aligned} \quad (16)$$

As mentioned before, such optimization procedure was implemented in LS-OPT using the Kriging metamodel. At each iteration step, considering the previous DOE experiments, the metamodel gets to the best solution until converge.

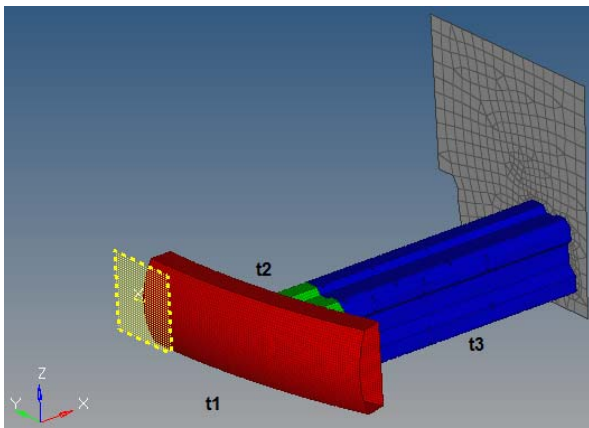

Fig. 9 Bumper parameters

TABLE III
 DESIGN PARAMETERS

Parameter	t1	t2	t3
Min (mm)	1	1	3
Max (mm)	6	6	6
Nom (mm)	1	3	5

IV. RESULTS AND DISCUSSION

Table IV shows the optimal values of wall thickness for the metamodel. In terms of objective and constraints values, it is possible to note how the metamodel is able to improve the basic configuration giving a feasible solution.

TABLE IV
 OPTIMAL RESULTS

	Basic	Kriging
t1	1	1
t2	3	5.3
t3	5	4.7
SEA (kJ/kg)	27.01	28.82
Max_acc (g)	239.77	79.12
Average_acc (g)	23.19	20.09
Max_stroke (mm)	656.15	598.32

The optimization histories for variables and objective at various iteration steps are shown in Fig. 10. Because the domain reduction strategy was adopted, the domain for each thickness tends to reduce in time up to arrive to convergence with the optimal solution. Moreover the SEA value tends to approach to a value of about 28 kJ/kg, considering a mass value equal to 2.5 kg.

The importance of the design variables can be determined through a sensitivity analysis. LS-OPT allows to use two sensitivity measures: Linear ANOVA and GSA/Sobol. The first measure depicts positive or negative influence of a variable, while the second one just shows the normalized absolute value and guarantees an easier comprehension (Fig. 11). It is evident how the t3 variable, that depicts the wall thickness of the last zone of the longitudinal crash box, is the most influential parameter for each response except for SEA, where the thickness of the transversal beam becomes very significant and cannot be neglected.

Fig. 12 represents the response surfaces in 3D representation achieved from the Kriging model and the simulation points for the SEA objective and mass response vs. two design variables, respectively. It is evident how for the SEA response surface the DOE experiments tend to concentrate on the maximum values of the quadratic surface, while an opposite behavior is evident for mass one where the trend is linear (green, red and purple points correspond to feasible, unfeasible and predicted optimum solutions, respectively).

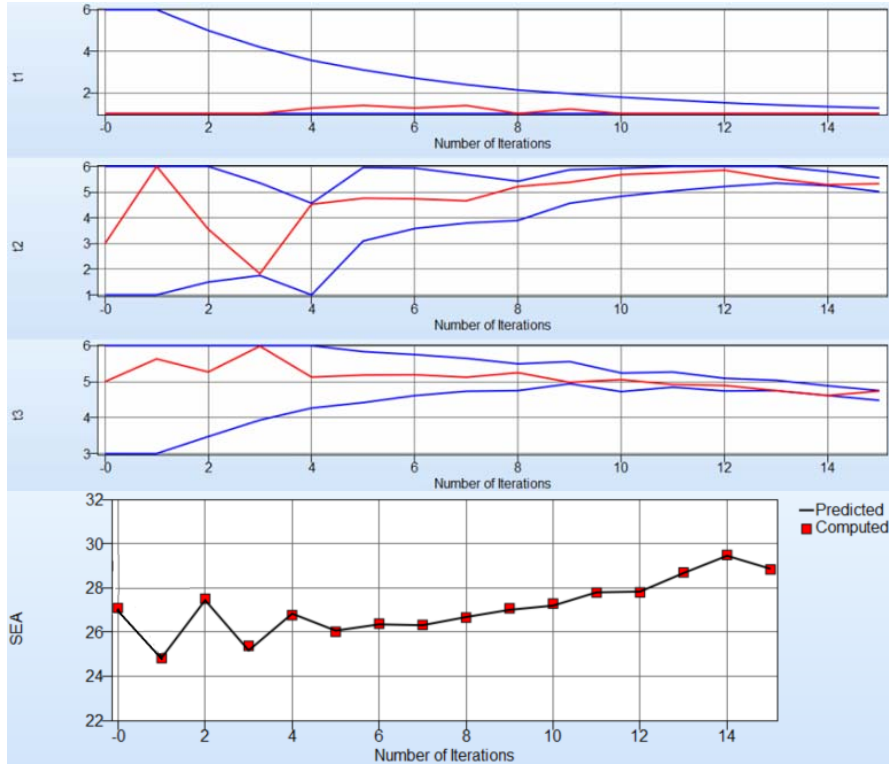

Fig. 10 Optimization history for the design variables and objective

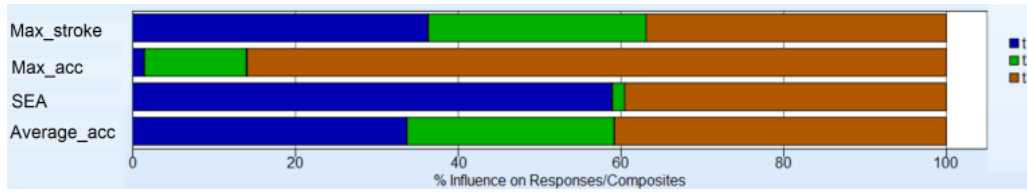
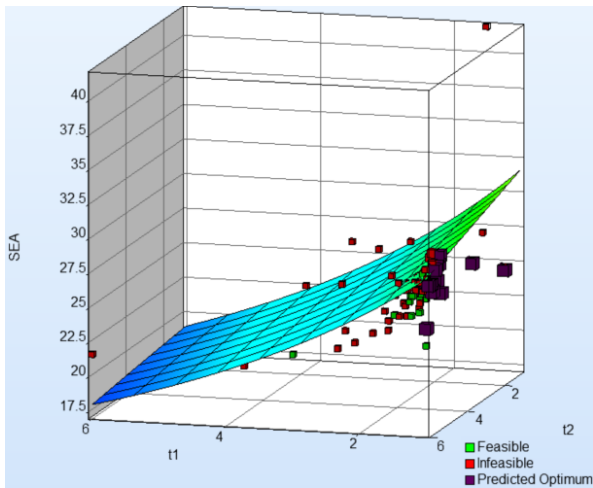
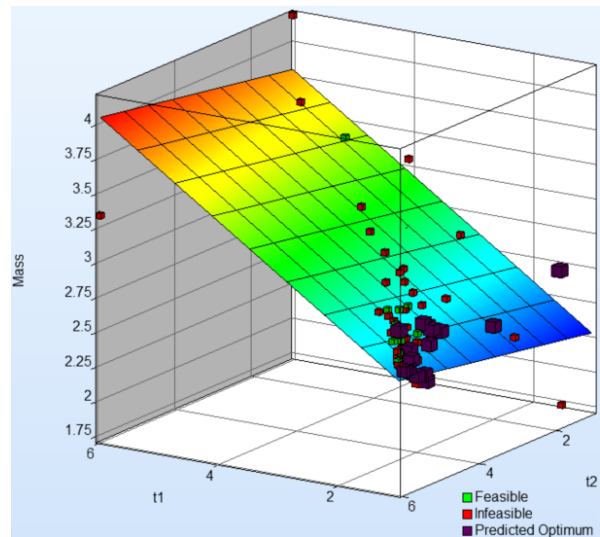

Fig. 11 Sobol values for multiple responses



(a)



(b)

Fig. 12 Response surfaces of (a) SEA and (b) mass

V. CONCLUSION

This paper presents the application of the Kriging metamodel in the context of crashworthiness. In particular the work is dedicated to the development of a front race car bumper subsystem made of composite material with the aim to improve its energy absorption capability. At first the beam curvature and the section profile were considered separately in order to identify the most promising structure. Only after, the chosen solution was analyzed with an optimization process using LS-OPT tool, by considering as design variables the wall thicknesses of the beam and of the longitudinal crash boxes. For this objective, numerical simulations were conducted through explicit solver LS-DYNA and structural results for the bumper were compared. The following conclusions can be drawn:

- After the initial deformation, where the only bumper is involved, the energy absorption is guaranteed from the longitudinal crash boxes and therefore it seems suitable to divide such structure at least in two zones at different thicknesses and insert some hole to reduce the peaks and guarantee a progressive and controlled deformation.
- It is not convenient to realize a bumper using a straight curvature, because it generates higher peak loads and involves only a small portion of the longitudinal crash box in the absorption.
- The adoption of a bumper with internal folds into the profile seems to be best in terms of progressive deformation, even if this implies a higher weight and a lower SEA value.
- Implementation of an optimization process through Kriging method demonstrated that it is possible to improve the crushing performance of the bumper system adopting a feasible solution.

REFERENCES

- [1] A. I. J. Forrester, A. Sobester, and A. J. Keane. Engineering Design via Surrogate Modelling - A Practical Guide. John Wiley & Sons Ltd., 2008.
- [2] S.S. Esfahlani, H. Shirvani, S. Nwaubani, A. Shirvani, H. Mebrahtu, "Comparative study of honeycomb optimization using Kriging and radial basis function", Theoretical and Applied Mechanics Letters, Vol. 3, (2013).
- [3] H. Wang, G.Y. Li, E. Li, Time-based metamodeling technique for vehicle crashworthiness optimization, Computer Methods in Applied Mechanics and Engineering, Vol. 199, N. 37-40, 2497-2509, (2010).
- [4] H. Fang, M. Rais-Rohani, Z. Liu, M.F. Horstemeyer, A comparative study of metamodeling methods for multiobjective crashworthiness optimization, Computers and Structures, Vol. 83, pp. 2121-2136, (2005).
- [5] M. Avalle, G. Chiandussi, G. Belingardi, Design optimization by response surface methodology: application to crashworthiness design of vehicle structures, Structural Multidisciplinary Optimization, Vol. 24, pp. 325-332, (2002).
- [6] G.G. Wang, S. Shan, Review of metamodeling techniques in support of engineering design optimization, Journal of Mechanical Design, Vol. 129, N. 4, pp. 370-380, (2007).
- [7] N. Stander, T. Goel, Metamodel sensitivity to sequential adaptive sampling in crashworthiness design, Proceedings of the 12th AIAA/ISSMO Multidisciplinary Analysis and Optimization Conference, Victoria, (2008).
- [8] J. Fang, G. Sun, N. Qiu, H.N. Kim, Q. Li, On design optimization for structural crashworthiness and its state of the art, Structural and Multidisciplinary Optimization, Vol. 55, N. 3, pp. 1091-1119, (2016).
- [9] F. Duddeck, S. Hunkeler, P. Lozano, E. Wehrle, D. Zeng, Topology optimization for crashworthiness of thin-walled structures under axial

impact using hybrid cellular automata, Structural and Multidisciplinary Optimization, Vol. 54, pp. 415-428, (2016).

- [10] A. Forrester, A.J. Keane, Recent advances in surrogate-based optimization, Progress in Aerospace Sciences, Vol. 45, N. 1-3, pp. 50-79, (2009).
- [11] N. Stander, K.J. Craig, On the robustness of a simple domain reduction scheme for simulation-based optimization, Engineering Computations, Vol. 19, N. 4, pp. 431-450, (2002).
- [12] G. Matheron. Kriging, or Polynomial Interpolation Procedures? A contribution to polemics in mathematical geology. Transaction, LXX:240, 244, 1967.
- [13] J. Sacks, S. B. Schiller, and W. J. Welch. Designs for Computer Experiments. Technometrics, 31(1), 1989.
- [14] D. R. Jones, M. Schonlau, and W. J. Welch. Efficient Global Optimization of Expensive Black-Box Functions. Journal of Global Optimization, 13(4):455,492, 1998.
- [15] N. Cressie. The origins of kriging. Mathematical Geology, 22(3):239, 252, 1990.
- [16] T. W. Simpson, J. D. Poplinski, P. N. Koch, and J. K. Allen. Metamodels for Computer-based Engineering Design: Survey and recommendations. Engineering with Computers, 17(2):129, 150, 2001.
- [17] J. P. C. Kleijnen. Kriging metamodeling in simulation: A review. European Journal of Operational Research, 192(3):707, 716, 2009.
- [18] S. Koziel, D. E. Ciaurri, and L. Leifsson. Surrogate-Based Methods. In Computational Optimization, Methods and Algorithms, Studies in Computational Intelligence, pages 33, 59. Springer Berlin Heidelberg, 2011. DOI: 10.1007/978-3-642-20859-1_3.
- [19] I. Arsenyev. Efficient Surrogate-based Robust Design Optimization Method. PhD thesis, Technische Universitat Munchen, 2017.
- [20] J. Sacks, W. J. Welch, T. J. Mitchell, and H. P. Wynn. Design and Analysis of Computer Experiments. Statistical Science, 4(4):433, 435, 1989.
- [21] G. Belingardi, A.T. Beyene, E.G. Koricho, Geometrical optimization of bumper beam profile made of pultruded composite by numerical simulation, Composite Structures, Vol. 102, pp. 217-225, (2013).
- [22] L. Farkas, S. Donders, D. Schildermans, D. Moens, D. Vandepitte, Optimisation study of a vehicle bumper subsystem with fuzzy parameters, Proceedings of ISMA2010-USD2010, pp. 5015-5026, (2010).
- [23] S. Boria, J. Obradovic, G. Belingardi, On design optimization of a composite impact attenuator under dynamic axial crushing, FME Transaction, 45 (3), 435-440, 2017.