

Conversion of HVAC Lines into HVDC in Transmission Expansion Planning

Juan P. Novoa, Mario A. Rios

Abstract—This paper presents a transmission planning methodology that considers the conversion of HVAC transmission lines to HVDC as an alternative of expansion of power systems, as a consequence of restrictions for the construction of new lines. The transmission expansion planning problem formulates an optimization problem that minimizes the total cost that includes the investment cost to convert lines from HVAC to HVDC and possible required reinforcements of the power system prior to the conversion. The costs analysis assesses the impact of the conversion on the reliability because transmission lines are out of service during the conversion work. The presented methodology is applied to a test system considering a planning a horizon of 10 years.

Keywords—Cost optimization, energy non supplied, HVAC, HVDC, transmission expansion planning.

I. INTRODUCTION

THE Transmission Expansion Planning (TEP) necessarily considers expansion of the existing infrastructure to meet the electric power demand growth. Recent studies have shown that the acquisition of rights of way for the construction of new transmission lines has higher costs and demanding restrictions due of environmental constraints, conditions that have guided research to find ways to improve the usage of existing transmission infrastructure [1]-[3].

Feasibility studies have shown that conversion of HVAC lines to HVDC lines increases the power transmission capability [1]. This fact lets the conversion HVAC to HVDC as an interesting alternative for the TEP, even more if restrictions to build new lines are more demanding. This paper proposes a TEP methodology that considers the conversion of HVAC transmission lines into HVDC lines, considering a scenario with restrictions for the construction of new lines. The methodology assesses the impact on the reliability during the periods that transmission lines selected for the conversion remain out of service, and considers the possibility of reinforcements on existing lines prior to conversion to reduce this impact.

II. CONVERSION OF HVAC TRANSMISSION LINES TO HVDC

A. Feasibility Conversion Studies

The conversion of HVAC lines to HVDC is an alternative recently analyzed and currently has very few cases

J. P. Novoa was with the Department of Electrical Engineering at Universidad de los Andes, Bogota, Colombia (e-mail: jp.novoa10@uniandes.edu.co).

M. A. Rios is with the Department of Electrical Engineering at Universidad de los Andes, Bogota, Colombia. (phone: +571-3394949 ext. 2826, e-mail: mrios@uniandes.edu.co).

implemented [4]. Several feasibility studies for conversion of lines describe the main aspects to take into account to increase the transmission capability. It is proposed two types of line's conversion [1]:

- *Type A*: Minor modifications in the structure that can be performed by changing the allowable height of the conductors with respect to ground during the conversion process.
- *Type B*: Major modifications of structures that do not allow conductors can be located at a suitable distance from ground during the conversion process.

Type A conversion could consider hot-line work to reduce the downtime of the line. This can be a key factor to reduce the impact on the reliability of the transmission system during the conversion process. Conversion Type B may require that the line remain out of service for extended periods, thus having a greater impact on the reliability of the system. However, the increase in transmission capacity can be higher than Type A conversion. Table I shows the results of feasibility studies and the conversion type according to [1], [5], [6].

TABLE I
 HVAC TRANSMISSION LINES CONVERSION TO HVDC – TECHNICAL FEASIBILITY

HVAC		HVDC		Capacity Increment [%]	Ref.	Conversion Type
AC Voltage (Double circuit)	MW	Bipolar Topology Voltage	MW			
145 kV	110	±290 kV	390	255%	[1]	Type B
245 kV	380	±490 kV	1.330	250%	[1]	Type B
362 kV	990	±725 kV	3.430	246%	[1]	Type B
362 kV	1.230	±725 kV	4.270	247%	[1]	Type B
420 kV	990	±840 kV	3.430	246%	[1]	Type B
420 kV	1.200	±400 kV	2.200	83%	[5]	Type A
420 kV	1.200	±450 kV	2.500	108%	[5]	Type A
287 kV	560	±240 kV	863	54%	[6]	Type A
287 kV	560	±245 kV	1.762	215%	[6]	Type B

The conversion of HVAC lines to HVDC reduces both the cost of investment and the Break Even Distance (BED). Conversion of lines can extend the distance range in which the HVDC is less expensive than HVAC for transmission lines. Fig. 1 shows in an illustrative way the reduction on BED.

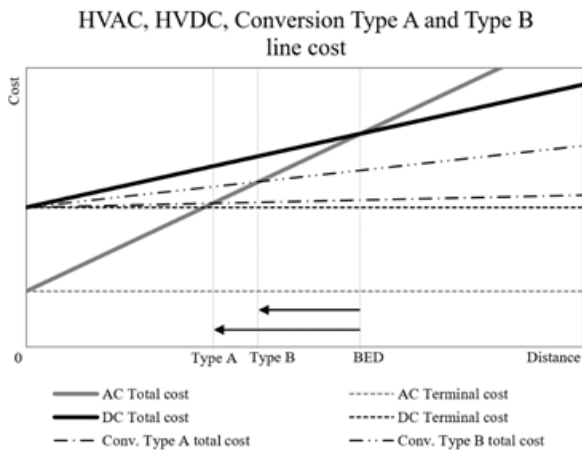

Fig. 1 BED for new HVAC and HVDC transmission lines, Type A and Type B conversion to HVDC

B. Technical Considerations for Line Conversion

The purpose of converting lines is to increase the power transmission capacity of a line already built; for that, the conversion considers the following technical issues:

- **Power Transmission Capacity:** HVDC allows the utilization of the thermal limit of the conductor. Transmission lines with voltage drop or stability limit restrictions may have great transmission capability increase with the conversion. HVDC voltage should be maximized to increase the transmission capability; however, the dimensions of the structure limit the insulation distances. Structure modifications allow larger insulation distances.
- **Conductor:** Conversion increases the power transmission capability, even preserving the conductors. If more power is required, it is possible to add conductors or change them for higher ampacity conductors. These changes are subject to mechanical strength of structures. It is recommended to make reinforcements to bear more weight, and additionally use lighter conductors with higher ampacity [2], [7], [8].
- **HVDC Operation Voltage:** The capacity of an HVDC transmission line depends directly on the operating voltage. The conversion type, A or B, can set a higher voltage level subject to the restrictions of line insulation and the modifications of the structure.
- **HVDC System Configuration:** It depends largely on the number of circuits of the existing line and the shape of the structure. HVAC single circuit lines allow conversion to a bipolar configuration. HVAC lines with more than one circuit allow conversion to two or more bipoles, which increases redundancy [9].
- **Insulation:** The HVDC insulation is more demanding because it requires higher creepage distance than HVAC for the same level of pollution and voltage [10]. Thus, if the conversion requires increasing the voltage level to achieve a higher increase in power transmission capability, the insulator strings will therefore require greater distance. Moreover, insulators for HVDC operation must have a specific construction type in

materials and coating for metallic parts. On the other hand, overvoltages caused by failures in HVDC are lower than HVAC because the control system can limit the fault current. HVAC overvoltages are between 2.5 pu - 2.8 pu [2], [11], whereas HVDC are between 1.5 pu - 1.85 pu, [12]. The above suggests that change the line insulation is necessary.

- **Structures:** The mechanical strength should be checked when the conversion involves adding more weight to the structure, or when the conversion requires modifications to increase the insulation distances.
- **Corona Losses:** Corona losses are not a relevant factor because it does not limit the feasibility of the conversion; however, the operating costs of the system consider corona losses [1].

C. Constraints for Line Conversion

Feasibility studies for the conversion of HVAC transmission lines into HVDC consider the following technical restrictions that set a limit on the operating voltage and current, and therefore the power transmission capability of the converted line:

- **Right of Way - ROW:** The existing right of way determines the point of measurement for ground level electric field and audible noise. These parameters may restrict HVDC voltage [1], [2].
- **Thermal Limit of Conductors:** Restricts the maximum current of the transmission line. To increase the current of the line it is necessary to add or change conductors.
- **Corona Phenomena:** Restricts the HVDC operation voltage. The parameter that most influence has on corona is the conductor surface gradient; however, restrictions are measured on side effects: ground level electric field and audible noise. The maximum values allowed at the bounds of the right of way are defined in local regulations. For audible noise, it is defined a limit between 39 dB and 53.1 dB [5], [6], [13]. For ground level electric field, [5] and [13] define a limit of 5 kV/m, whereas [6] defines a limit of 16 kV/m.
- **Insulation:** Changes of HVDC operation voltage, length of the insulator strings and position of the conductors makes it necessary to check the performance of the insulation during normal operation and overvoltage. Usually, it is necessary to increase the length of the insulator string for which it is appropriate to adopt configurations in "V" instead of suspension or "I" [1].

III. OBJECTIVE FUNCTION AT TEP

In this paper, the TEP is a minimization problem of the total cost of the feasible alternatives of expansion through conversion of HVAC lines to HVDC. The planning period is T years, such that $t \in T$, and the discount rate is r . The total cost includes the investment cost, operation cost and cost of energy not supplied; as:

$$\min C_{INV} + C_{OP} + C_{ENS} \quad (1)$$

C_{INV} is the investment cost that includes capital, financial and administrative costs of each alternative for every year t , given by:

$$C_{INV} = \sum_{t \in T} \sum_{(i,j \in LT_{AC})} (CONV_{ik}(t) + REF_{j(i,k)}(t)) \times (1+r)^{-t} \quad (2)$$

where a HVAC transmission line i can have k alternatives of conversion to HVDC. Each alternative $CONV_{ik}$ may require an additional reinforcement $REF_{j(i,k)}$ of line j prior to the conversion of line i .

The C_{OP} at (1) is the operation cost of the transmission system computed as the cost of power losses (C_{LOSS}) at year t in lines and HVDC converter stations, and the operation, maintenance, and administration costs (C_{AOM}), as:

$$C_{OP} = \sum_{t \in T} (C_{LOSS}(t) + C_{AOM}(t)) \times (1+r)^{-t} \quad (3)$$

The C_{ENS} at (1) is the cost of energy not supplied that results from the computed energy not served for each year t at bus n , and the corresponding unitary cost of the loss of load (CU_{ENS}):

$$C_{ENS} = \sum_{t \in T} \sum_{n \in N} (CU_{ENS}(n,t) \times ENS(n,t)) \times (1+r)^{-t} \quad (4)$$

The TEP minimization problem (1) can be solved by mathematical or heuristic methods.

IV. TEP METHODOLOGY WITH CONVERSION OF HVAC LINES TO HVDC LINES

Fig. 2 presents the proposed methodology for TEP with conversion of HVAC lines to HVDC.

The methodology as four stages: A- computation of HVAC transmission system capacity, B- identification of suitable transmission lines for conversion, C- formulation of feasible conversion alternatives, and D- assessment of the conversion alternatives and definition of TEP's plan.

The HVAC transmission system capacity is determined by computing the Demand Not Supplied (DNS) on each bus n according to the demand forecast, in order to identify the transmission lines that have restrictions. As a result, a set of buses $N_{DNS \neq 0}$ with a DNS different from zero at the last year is obtained, and its value for each bus n is DNS_n .

For each bus of the set $N_{DNS \neq 0}$, a set of suitable lines i for conversion are identified using the following criteria: line i transmits power to bus n from a bus or area that has generation surplus, and line i has thermal limit, voltage drop or stability limit restrictions. From this analysis, it is obtained the set of transmission lines $i \in TL_{FCA_n}$ that are suitable for conversion, for each bus n .

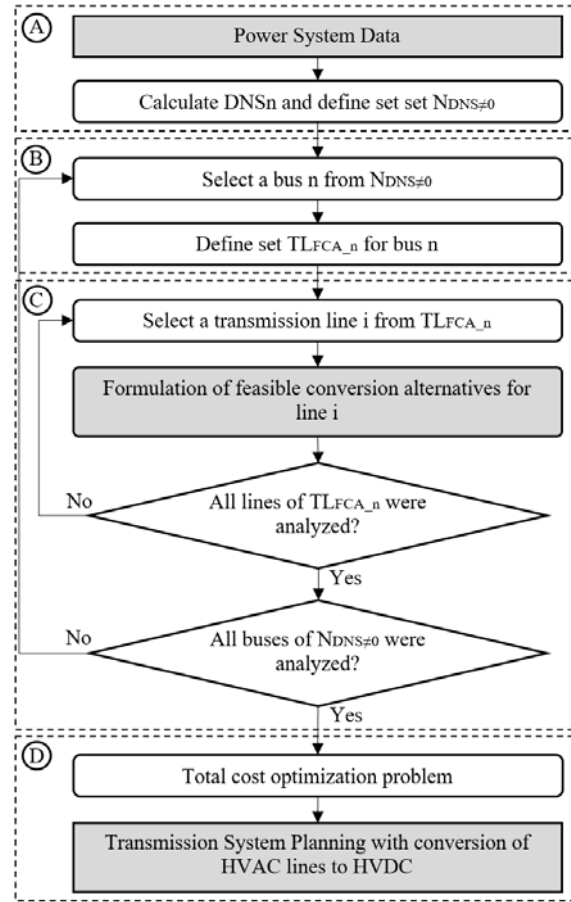

Fig. 2 Methodology for TEP with conversion of HVAC to HVDC

Then, a feasibility conversion study is required to develop the conversion alternatives that meet the requirements for additional transmission power capacity, subject to technical restrictions. Fig. 3 presents the methodology that allows the formulation of one or more feasible conversion alternatives for conversion of transmission line i . The methodology has the following five stages:

- *Information for the feasibility conversion study of the transmission line:* Technical information of the line i as construction characteristics, maximum load, defined as i_{Lmax} , and data or constraints from local regulation are required.
- *Estimation of the window of time for converting a transmission line:* The conversion may require work on the transmission line that requires only the line is out of service. To assess the impact of the unavailability of the transmission line i during conversion, the energy not supplied ENS_{N-i} must be calculated in a permanent operating condition $N-I$, in which the line i is removed. The window of time i_{WT} is defined as the period, in years, where the ENS_{N-i} remains at comparable values with respect to the ENS of the base case. The energy not supplied can be calculated by methods such as state space enumeration or Monte Carlo simulation.
- *Formulation of conversion alternatives for the transmission line:* It is possible to formulate k conversion

alternatives for transmission line i , each one of them defined as $CONV_{i,k}$. For each alternative k , the power that can be achieved through the conversion, defined as $PCONV_{i,k}$, should be determined. This power must be greater than the sum of the maximum HVAC load of i and the corresponding demand not supplied of the bus n :

$$PCONV_{i,k} > i_{Lmax} + DNS_n \quad (5)$$

It is recommended to first assess if Type A conversion can achieve the power requirements. Eventually, the analysis leads to an alternative that finds the maximum capacity without major modifications of the structure. If Type A conversion does not achieve the power requirements, or if it is desirable to formulate an alternative with higher capacity, a Type B conversion should be formulated.

- *Defining strategies for converting a transmission line:* Strategies for converting a transmission line i should be restricted as far as possible to the window of time i_{WT} , in order to avoid high costs of energy not supplied (CENS), and thus maintain competitiveness over other alternatives considered in the transmission planning.

It may be necessary to formulate reinforcements on other lines prior to conversion of i , to increase the window of time i_{WT} , e.g. series compensation or FACTS. The methodology considers a reinforcement of the transmission line j in the k conversion alternative of line i , defined as $REF_{j,(i,k)}$. It is possible that any reinforcement cannot reduce the window of time. In such case, the conversion alternative will have high CENS.

Strategies for conversion must consider time for engineering, approval of budgets and contracts, purchase of equipment and construction, testing and commissioning for both conversions as reinforcements. In addition, set criteria to reduce unavailability of transmission lines during conversion, for example live line technology.

- *Formulation of feasible alternatives for converting a transmission line:* The formulation of each alternative must have the technical characteristics of the HVDC line, and prior reinforcement if required, the implementation strategy and investment resources [14].

V. APPLICATION TO THE TEST SYSTEM

A. Test System

Fig. 4 shows the test system that is a modification to three area system of the original Kundur's power system [15]. Table II presents generation and load data of each area. Table III presents reliability data. Fig. 5 presents the shape of the structure assumed for transmission lines 7-9, 7-9 and 8-9 [16].

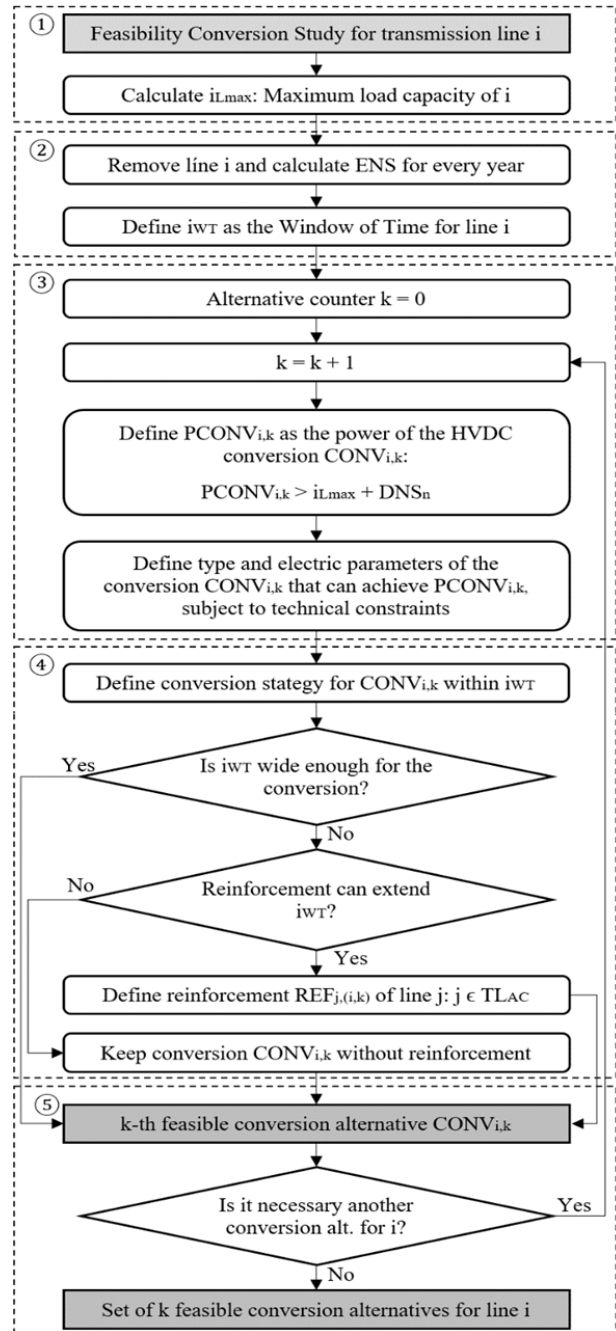

Fig. 3 Formulation of feasible conversion alternatives for transmission line i

TABLE II
 GENERATION AND LOAD CHARACTERISTICS – TEST SYSTEM

Area	Generation	Load (Year 0)	Load (Year 10)	Load Growth Rate
1	4 x 750 MW	543 MW	766 MW	3.5 %
2	2 x 750 MW	1269 MW	1790 MW	3.5 %
3	---	269 MW	418 MW	4.5 %

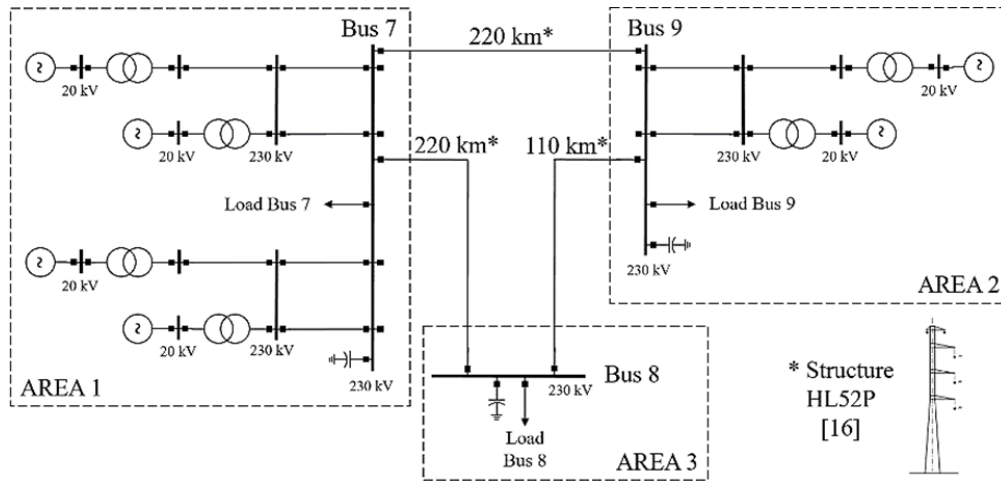

Fig. 4 Test System

TABLE III
 RELIABILITY DATA OF EQUIPMENT FOR THE TEST SYSTEM

Equipment	Failure rate (Fails/year)	Mean time to repair (Hour)
Power transformer [17]	0.012	116
Valve bridge [17]	0.143	53
AC filter [18]	0.010	48
Reactive power source [18]	0.002	12
Smoothing reactor [18]	0.030	66
DC filter [18]	0.250	12
AC breaker [18]	0.010	48
Transmission line 230 kV	0.005497	12.3
HVAC [19]	[f/yr-km]	
HVDC pole [17]	0.440 [f/yr-km]	7

TABLE IV
 SUITABLE TRANSMISSION LINES FOR CONVERSION – TEST SYSTEM

Line	Loadability	Technical Restriction	Line from area with generation surplus	Suitable line to convert
7-9	76.2 %	Voltage drop	Yes	Yes
7-8	92.5 %	Voltage drop	Yes	Yes
8-9	30.0 %	None	No	No

C. Alternatives of Conversion

The reliability evaluation of the test system in normal operation and $N-1$ condition, by removing the transmission lines 7-8 and 7-9, is presented in Fig 6. Taking as reference the ENS of year 8, in which the HVAC system begins to have significant restrictions in transmission, the windows of time to convert the lines are $(7-8)_{WT} = 3$ years, and $(7-9)_{WT} = 4$ years.

The structure can be converted to a bipolar configuration of ± 400 kV if the lower phase is grounded [16]; however, isolation distances with safety margins are tight, so in this paper the operating voltage is reduced to ± 350 kV. Being the thermal limit the conductor 950 A, and conversion type A can increase the transmission capacity up to 665 MW, which comfortably meets the criteria of (5). Furthermore, it is estimated that the cost of the line conversion is 10% of the cost of a new HVDC line. According to the methodology, the following three alternatives are formulated:

- $CONV_{(7-9),1}$: 40% series compensation of line 7-8, then conversion of line 7-9.
- $CONV_{(7-8),1}$: 40% series compensation of line 7-9, then conversion of line 7-8.
- $CONV_{(7-9),2}$: Conversion of line 7-9.

Table V presents the strategy of conversion of each one of these alternatives.

D. Assessment of Alternatives

The assessment of ENS of the three alternatives is presented in Fig. 7. The alternatives $CONV_{(7-9),1}$ and $CONV_{(7-9),2}$ have the least impact on ENS because the conversion strategy is within the window of time $(7-9)_{WT}$ that is 4 years. The alternative $CONV_{(7-8),1}$ significantly affects the ENS, specifically in year 4, because the strategy to implement the conversion exceeds a 1 year window of time $(7-8)_{WT}$.

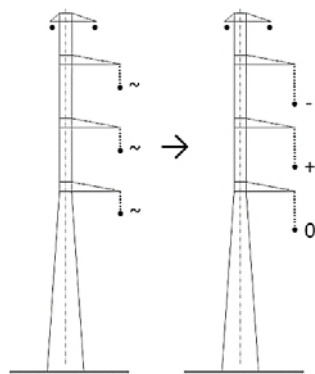

Fig. 5 Conversion of structure HL52P from HVAC single circuit to HVDC bipolar configuration [16]

B. Identification of Suitable Lines for Conversion

According to the demand forecast, the system has DNS at buses 8 and 9 at year 7 and 8, respectively. From these results, it is obtained the set $N_{DNS \neq 0}$ as {Bus 8, Bus 9}, and the requirements of additional power are $DNS_8 = 64.6$ MW, $DNS_9 = 173.5$ MW. Bus 7 has no restrictions for power supply because it is in an area with generation surplus. Table IV presents the transmission lines that are suitable for conversion. From the analysis, it is obtained that the HVAC maximum transmission capacity of transmission lines suitable for conversion is $(7-8)_{Cmax} = 285$ MW and $(7-9)_{Cmax} = 244$ MW.

TABLE V

HVAC TO HVDC CONVERSION STRATEGIES – TEST SYSTEM			
Year	CONV _{(7-9),1}	CONV _{(7-8),1}	CONV _{(7-9),2}
1	Series compensation work begins Conversion feasibility study		Conversion feasibility study
2	Series compensation commissioning and testing		Line conversion (change of insulation)
3	HVDC converter station work begins Line conversion (change of insulators)		HVAC operation of converted line
4	Continue HVDC converter station work		
5 – 10	HVDC transmission line commissioning and testing		Normal operation of transmission system

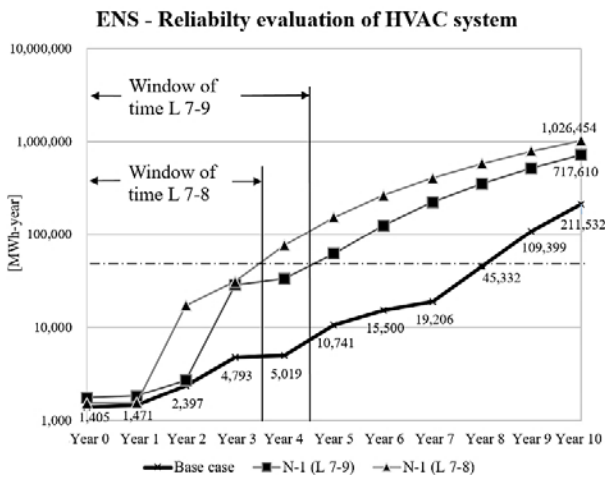

Fig. 6 ENS of test system for base case and N-1 condition

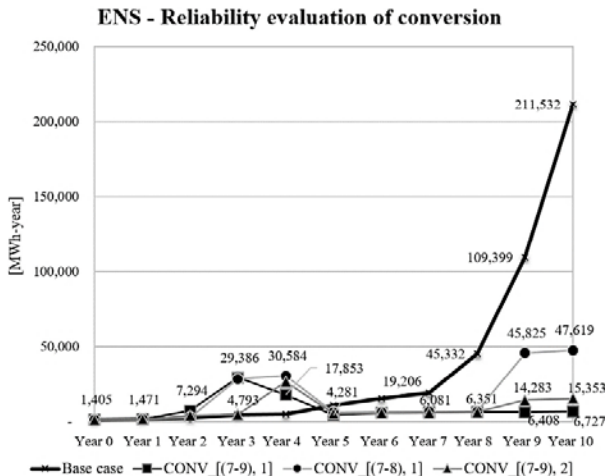

Fig. 7 Assessment of ENS for the base case and conversion alternatives

The total cost of the base case and the three alternatives is presented in Fig. 8. Alternatives $CONV_{(7-9),1}$ and $CONV_{(7-8),1}$ have the same investment cost. The alternative $CONV_{(7-9),2}$ has less investment because it does not require series compensation.

The most relevant factor on total cost is the cost of the energy not supplied, for which a value of loss of load of 4.3 USD/kWh was used [20]. The cost of ENS of alternative

$CONV_{(7-9),2}$ is the lowest because the conversion of the line is made at year 2, whereas the other two alternatives perform the conversion at year 3.

Alternative $CONV_{(7-9),1}$ has the lower ENS in years 9 and 10 because of the increase of transmission capacity of line 7-8; series compensation increases the transmission capacity of this line up to 310 MW. Alternative $CONV_{(7-8),2}$ has the highest cost mainly due to the unavailability of the line 7-8 at years 4, 9 and 10.

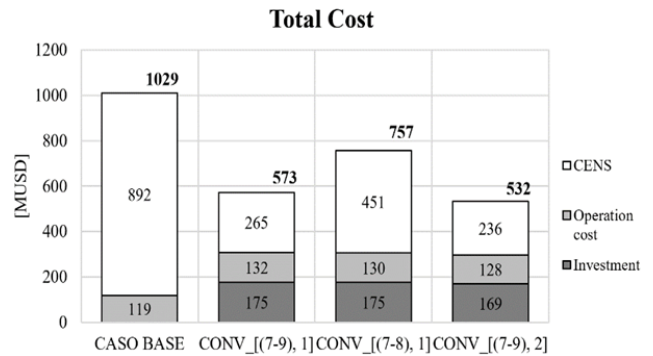

Fig. 8 Assessment of the total cost for base case and conversion alternatives

VI. CONCLUSIONS

This paper has shown a methodology for TEP considering the conversion of HVAC lines to HVDC transmission in a scenario with restrictions to build new lines. The methodology includes reinforcements at the transmission system prior to the conversion in order to reduce the negative impact on the reliability of the system during the conversion of lines.

A feasibility conversion study allows the identification of modifications that can be made to increase the power transmission capacity of an HVAC line. The HVAC transmission lines that may have greater increase of power with conversion to HVDC are those that the maximum operating current is much less than their thermal limit, this is because HVDC allows reaching the maximum current in the conductor under normal operating conditions.

REFERENCES

- [1] A. Clerici, L. Paris, and P. Danfors, "HVDC conversion of HVAC lines to provide substantial power upgrading," *IEEE Transactions on Power Delivery*, vol. 6, no. 1, pp. 324-333, Jan. 1991.
- [2] M. Marene, I. Zamora, O. Abarrategui, and Z. Aginako, "Conversion of AC distribution lines into DC lines to upgrade transmission capacity," *Electric Power Systems Research*, vol. 81, no. 7, pp. 1341-1348, July 2011.
- [3] M. Marene, I. Zamora, O. Abarrategui, and Z. Aginako, "VSC-HVDC configurations for converting AC distribution lines into DC lines," *Electric Power and Energy Systems*, vol. 54, pp. 589-597, Jan. 2014.
- [4] M. Khan, R. and Agrawal, "Conversion of AC line into HVDC," in *2005 IEEE Power Engineering Society Inaugural Conference and Exposition*, Durban, South Africa, July 2005, pp. 51-56.
- [5] J. Lundkvist, I. Gutman, and L. Weimers, "Feasibility study for converting 380 kV AC lines to hybrid AC / DC lines," in *EPRI High-Voltage Direct Current & Flexible AC Transmission Systems Conference*, Westminster, USA, Nov. 2009, pp. 1-25.
- [6] M. Beshir, L. Barthold, and D. Woodford, "Prospective AC to DC conversion of two parallel 287 kV transmission lines in the Western US," in *Proc. CIGRE Session 44*, Paris, France, 2012.

- [7] V. K. Sood, "HVDC Transmission", in *Power Electronics Handbook*, 3rd ed., M.H. Rashid, Ed. Elsevier, 2011, pp. 823-849.
- [8] K. Meah, and S. Ula, "Comparative evaluation of HVDC and HVAC transmission systems," in *Proc. IEEE Power Engineering Society General Meeting*, Tampa, USA, June 2007.
- [9] L. Barthold, R. Adapa, H. Clark, and D. Woodford, "System advantages in conversion of AC transmission lines to DC," in *9th IET International Conference on AC and DC Power Transmission*, London, England, Oct. 2010.
- [10] F. Kiessling, P. Nefzger, J. Nolasco, and U. Kaintzyk, *Overhead Power Lines*, Berlin: Springer-Verlag, 2003.
- [11] T. Gönen, *Electric Power Transmission System Engineering Analysis and Design*, 2nd ed, CRC Press, 2009.
- [12] CIGRE Task Force JWG-B2/B4/C1.17, Impacts of HVDC Lines on the Economics of HVDC Projects, CIGRE, Brochure 388, 2008.
- [13] P. Naidoo, "Investigations into the Upgrading of Existing Transmission Lines from HVAC to HVDC," in *Proc. IEEE Power and Energy Society General Meeting*, San Diego, USA, July 2011.
- [14] A. Edris, L. Barthold, D. Douglas, W. Litzenberger, and D. Woodford, "Upgrading AC Transmission to DC for maximum power transfer capacity," in *12th International Middle-East Power System Conference*, Aswan, Egypt, March 2008, pp. 44-49.
- [15] P. Kundur, *Power System Stability and Control*, New York: McGraw-Hill, 1994.
- [16] A. Orzechowski, "Analysis of possible enhancement of transmission capacity while converting 220kV alternating current overhead lines into direct current lines," in *Proc. CIGRE Session 36*, Paris, France, 2005.
- [17] L. Wang, G. Wang, and B. Li, "Reliability evaluation of UHVDC systems using Monte Carlo simulation," in *Proc. IEEE Power and Energy Society General Meeting*, Calgary, Canada, July 2009.
- [18] R. Billinton, M. Fotuhi-Firuzabad, S. Faried, and S. Aboreshai, "Composite system reliability evaluation incorporating an HVDC link and a static synchronous series compensator," in *IEEE CCECE Canadian Conference on Electrical and Computer Engineering*, Winnipeg, Canada, 2002, pp. 42-47.
- [19] R. Billinton, R. Ghajar, F. Fillipelli, and R. Del Blanco, "Transmission equipment reliability using the Canadian Electrical Association Information System," in *Second International Conference on the Reliability of Transmission and Distribution Equipment*, Coventry, UK, March 1995, pp.13-18.
- [20] London Economics, "The Value of Lost of Load (VoLL) for electricity in Great Britain," London, 2013.

Juan P. Novoa. He was born at Bogota in 1979. He is an electrical engineer (2004) from Universidad Nacional de Colombia and M.Sc in electrical engineering (2016) from Universidad de los Andes, Bogota, Colombia. His fields of interest are power system control and stability, power system analysis and planning.

Since 2005, he is an engineer of ECOPETROL, Colombia.

Mario A. Ríos. He was born at Bogota in 1968. He is an electrical engineer (1991) and M.Sc in electrical engineering (1992) both from Universidad de los Andes, Bogota, Colombia. He has a Ph.D. Degree in electrical engineering from both INPG-LEG (1998), France, and Universidad de los Andes (1998). His field of interest are power system control and stability, power system analysis and planning.

He was a consultant engineer at Consultoria Colombiana S.A. 1991-1995 and Project Manager 1999-2005. He was a Research Associate at University of Manchester (Formerly UMIST), at UK. Currently, he is Full Professor at the Department of Electrical Engineering at School of Engineering at Universidad de los Andes, Bogota, Colombia.

Prof. Rios is IEEE Member since 1989.