

# Hybrid Heat Pump for Micro Heat Network

J. M. Counsell, Y. Khalid, M. J. Stewart

**Abstract**—Achieving nearly zero carbon heating continues to be identified by UK government analysis as an important feature of any lowest cost pathway to reducing greenhouse gas emissions. Heat currently accounts for 48% of UK energy consumption and approximately one third of UK's greenhouse gas emissions. Heat Networks are being promoted by UK investment policies as one means of supporting hybrid heat pump based solutions. To this effect the RISE (Renewable Integrated and Sustainable Electric) heating system project is investigating how an all-electric heating sources hybrid configuration could play a key role in long-term decarbonisation of heat. For the purposes of this study, hybrid systems are defined as systems combining the technologies of an electric driven air source heat pump, electric powered thermal storage, a thermal vessel and micro-heat network as an integrated system. This hybrid strategy allows for the system to store up energy during periods of low electricity demand from the national grid, turning it into a dynamic supply of low cost heat which is utilized only when required. Currently a prototype of such a system is being tested in a modern house integrated with advanced controls and sensors. This paper presents the virtual performance analysis of the system and its design for a micro heat network with multiple dwelling units. The results show that the RISE system is controllable and can reduce carbon emissions whilst being competitive in running costs with a conventional gas boiler heating system.

**Keywords**—Gas boilers, heat pumps, hybrid heating and thermal storage, renewable integrated & sustainable electric.

## I. INTRODUCTION

CURRENTLY the electrical grid and distribution networks are facing a challenging task of managing a demand profile that is increasingly dynamic. A significant contribution has been from low and zero carbon (LZC) technologies, electric heating systems and vehicles [1], [2]. Majority of energy is consumed in homes by providing hot water and space heating which are the key to achieving future energy security and carbon reduction [3].

Heat pumps are identified as a key technology which could significantly contribute to reducing domestic energy load and decarbonisation through electrification of heat [3]. In the winter season however, when household electricity demands are high, the heat pump consumption is also the highest due to the higher space heating demand [3]. It is well established that the heat-pump can only be efficient up to a minimum outside temperature below which its instantaneous Coefficient of Performance (COP) and its consequent Seasonal Performance Factor (SPF) reduce significantly making it more expensive to

run and more carbon intensive [4], [5] than standard dwelling heating systems such as gas condensing boilers (GCB). Hence there is a need in winter for additional cost effective low carbon heat source that can top-up when required without driving the heat pump into inefficient regions of operation. In addition with the widespread electrification of heating via heat pumps would add significant pressure on electrical infrastructure, in particular an increase of peak demand at winter evening peak times when the network is usually under greatest stress.

One common hybrid strategy current available in the market is where gas condensing boilers (GCB) is utilized in combination with heat-pumps [6], [7]. This type of hybrid arrangement has been shown to improve the performance of heat pumps and in addition the traditional GCB compensates for where heat pump cannot provide enough cost-effective heat due to unfavourable weather conditions [8]. Another hybrid strategy, thermal storage with heat-pumps has also been previously researched [9], [10]. This hybrid strategy allows for using off peak electricity to charge a thermal storage device for using that heat during the peak times of the day.

This paper presents the RISE project which has utilised heat pumps and thermal storage technologies in an innovative topology and component configuration resulting in an all-electric hybrid heating strategy capable of competing with GCB only heating systems.

## II. THE RISE HEATING SYSTEM

The RISE heating system aims to improve the performance of heat pumps through utilising an electric thermal store (QB – referred to as the Quantum Boiler) and hot water storage tank. The schematic of the system configuration is shown in Fig. 1.

As shown above the system is comprised of two electric heating systems and a hot water storage tank. The heat pump and a thermal storage device (i.e. QB - Quantum Boiler) are set up to feed into one hot water storage tank and this has provided a heat load for the purposes of the prototype trial. The system is currently installed for prototype trial in a modern house in UK at Building Research Establishment (BRE) Ltd Innovation Park as shown in Fig. 2.

The heat pump in this system operates as the primary heat source, heating the water to 55°C which is stored in a thermal storage tank. The hot water is drawn from the storage tank when required for heating and circulated through the standard radiator system in the dwelling. The thermal storage heater (QB -Quantum Boiler) is used as a secondary heating source for heat top-up during peak periods by charging the core during off peak times.

The quantum boiler stores up energy during periods of low

Y. Khalid is a Research Assistant at the Electronic & Electrical Engineering Department, University of Chester, Chester, CH1 4BJ, UK (phone: 0044 1244 512541; e-mail: y.khalid@chester.ac.uk).

J. M. Counsell and M. Stewart are with the Department for Electronic & Electrical Engineering Department, University of Chester, Chester, CH1 4BJ, UK (e-mail address: j.counsell@chester.ac.uk, m.stewart@chester.ac.uk).

electrical demand, turning it into efficient heat only when needed. The quantum boiler has a storage core which is heated up using off-peak electricity and a forced air heat exchanger is used for extraction of heat. The position and angle of the fans is optimised to generate a directed stream of air through the storage core necessary for a more rapid extraction of the stored energy. The rate at which that energy is being released across the design discharge period has been significantly improved with an averaged output of 1.93 kW for the first 4 hours. The ability of the Quantum Boiler to self-regulate has

also been introduced. A series of mechanical and software safety mechanisms now regulate the time and temperature control for the system to operate during charging and discharging periods bringing us in line with the preferred control methodology for the RISE system. A Glen Dimplex 3.5kW "A\* Class" rated air to water heat pump and hot water storage tank have been installed and commissioned adjacent to the prototype 3kW thermal storage heater (Quantum Boiler) also designed by Glen Dimplex and hot water storage tank.

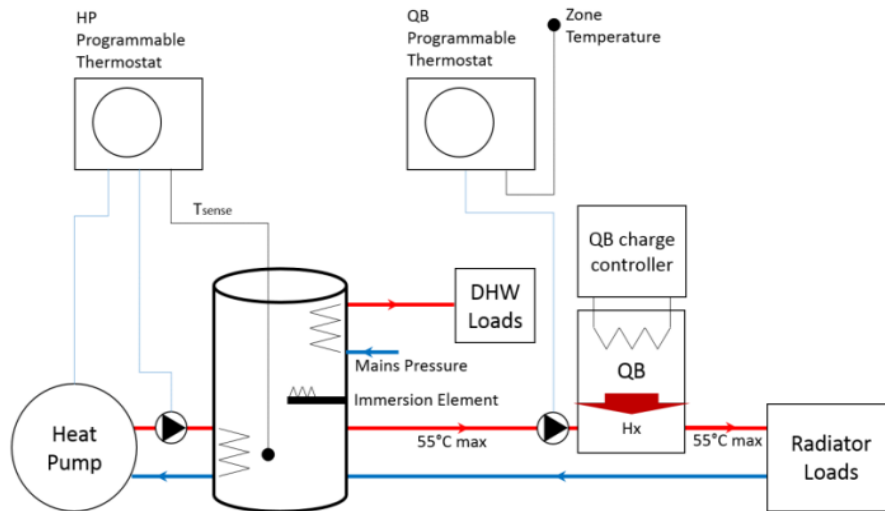

Fig. 1 RISE system general topology and control system configuration



Fig. 2 (a) Building Research Establishment (BRE) Natural House, (b) Glen Dimplex heat pump, (c) Glen Dimplex Quantum Boiler, (d) Hot water storage tank

Dimplex using thermostats, charge controllers, pumps and on-board controls of Heat pump, Quantum Boiler and Thermal tank. As shown in Fig. 1, there are two thermostats, one controlling the heat pump to maintain 55°C water temperature in the hot water tank. The second thermostat controls the Quantum Boiler for reheating water supply to 55°C during the on peak period (4-8 pm) when the heat pump is off for maintaining the required zone temperature set-point at 21°C. In the test trial, programmable room thermostats are used which control the operation of primary circulation pump to heat the hot water tank, secondary circulation pump to heat the house via radiators and enable the Quantum Boiler subject to its internal time clock. The heat pump and quantum boiler are scheduled for operation as shown in Table I:

TABLE I  
 RISE SYSTEM OPERATIONAL SCHEDULE

Heat Pump Time Clock		Quantum Boiler Time Clock (Interrupt period)	
Mon-Fri	Sat-Sun	Mon-Sun	
05:30On	05:30On		
07:00Off	07:00Off	07:00	On
14:30On	09:00On	09:00	Off
16:00 Off	16:00Off	16:00	On
20:00On	20:00On	20:00	Off
22:00Off	22:30Off		

Note: Quantum Boiler fan heat exchanger only operates during these times when the occupancy programmable thermostat requires heat.

The control system and scheduling is configured by Glen

In this hybrid configuration the initial results have shown a better energy performance in terms of reduced carbon

emissions than the traditional gas condensing boiler (GCB) system as found in most UK homes. Note: In Fig. 1 domestic hot water (DHW) loads are shown for completeness. In this test house trial however, DHW is not included.

Further sections describe the design of the RISE system, simulation model, test trials of the prototype system, the preliminary energy simulation results in comparison to standard gas condensing boiler (GCB) heating systems and application of the system to local energy system.

### III. MODELLING AND SIMULATION

#### A. Methodology

The UK implements carbon emissions policy for buildings to European Performance of Buildings Directive (EPBD) Standards through mandated energy performance benchmarks and certification [11]. Statutory requirements for buildings are given by the UK's building regulations, providing materials, construction and energy performance expectations to demonstrate compliance [12]. Compliance with these regulations and EPBD targets are achieved through use of certification using quasi-steady state benchmark energy assessment methods; SAP and SBEM [13], [14]. Dynamic simulation software is also widely used by industry in providing a mechanism to rapidly simulate a building or zone to determine and assess its thermal and electrical responses to demands and disturbances [15].

The IDEAS (Inverse Dynamics based Energy Assessment and Simulation) framework is a dynamic modelling and numerical calculation environment developed using Robust Inverse Dynamics Estimation (RIDE) and small perturbation theory to accurately simulate energy utilisation and complex control systems interaction with building and its energy systems such as CHP, photovoltaic etc. [16], [17]. The IDEAS framework is implemented in MATLAB and Simulink software package. The fundamental physics is represented by a state-space model describing the dynamic behaviour of the building and its systems for small amplitude of perturbation ( $\delta$ ) about a steady state condition:

$$x_0 + \delta \dot{x}(t) = A(x_0 + \delta x(t)) + B(u_0 + \delta u(t)) + E(d_0 + \delta d(t)) \quad (1)$$

$$y_0 + \delta y(t) = C(x_0 + \delta x(t)) + D(u_0 + \delta u(t)) + F(d_0 + \delta d(t)) \quad (2)$$

This framework has been validated against the UK's energy assessment method SAP using measured data [18]. Building modelling methods and energy assessment procedures were adopted as given by the National Calculation Methodology (NCM) and complementary reference datasets [19], and by CIBSE environmental performance benchmarks [20], [21]. The simulation results produced were validated against NCM demand data and CIBSE environmental benchmarks. Hence, the multi-domain building physics model is also intended to be comparable with energy assessment using SAP, SBEM and by extension, other quasi-steady state and dynamic energy assessment packages such as IES, TAS which refer to NCM as their core benchmark compliance data

source. The IDEAS framework is applied in this paper to host a complex multi-domain Air-source Heat pump, thermal storage heater with hot water storage tank to establish thermal and electrical energy required to track a desired zonal set-point temperature at a 1 minute sampling rate.

#### B. RISE and GCB System Physics

The heat pump has been previously modelled for IDEAS framework [22], [23] taking into account the dynamic nature of the system efficiency and thermal capacity. The heat pump heat output is modelled based on coefficient of performance COP and maximum heat output  $Q_{HP\ max}$ . The RISE system uses air source heat pump (ASHP) and its performance depends on outside conditions such as an ambient temperature, relative humidity and return temperature (in RISE case return water temperature from the thermal tank). A regression model was derived for the COP and  $Q_{HP\ max}$  from test data as follows:

$$COP = 6.70e^{-0.022\Delta T} \quad (3)$$

$$\Delta T = T_{return} - T_{external} \quad (4)$$

$$\dot{Q}_{HP\ max} = 0.023T_{external} - 0.0031T_{return} - 4.46 \quad (5)$$

Rate of heat output for air source heat pump in the RISE system is modelled with:

$$\dot{Q}_{boiler\_HP} = \left(\frac{1}{\tau_{hp}}\right) ((COP u(t)G_C) - Q_{HP}) \quad (6)$$

This includes heat pump compressor dynamics represented as a first order lag with saturation limits on power & heat output and compressor time constant set at 5 minutes ( $\tau_{hp}$ ) depending on compressor gain given as  $G_C$ .

The thermal storage heater (QB) is modelled as an ideal heat store and heat exchanger. The dynamics of the heat exchanger and thermal core are modelled by first order lag as above for heat pump. The time constant for thermal core was set at 24 hours with limits on maximum core temperature and maximum changing power rating (2.4 kW). The temperature of the core is modelled as follows:

$$\dot{T}_{core\_QB} = \left(\frac{1}{\tau_{QB}}\right) (Q_{charge} - Q_{output} - Q_{loss}) \quad (7)$$

The heat exchanger was also modelled in the same way with 5 minutes time constant ( $\tau_{hx}$ ) having limits on power and heat gain. General first order difference equation is given as follows:

$$\dot{Q}_{output} = \left(\frac{1}{\tau_{hx}}\right) (k_{hx} Q_{output}) \quad (8)$$

The heat pump and quantum boiler water loops connected to the hot water tank are modelled using steady-state heat transfer equations using mass flow rate, temperature difference and heat provided by heat pump and quantum boiler. The rate of change in water temperatures in the loops are dictated by the dynamics of the HP and QB given above and change in water temperature of the system is given by:

$$\dot{T}_{system\ water} = \left(\frac{1}{c_p \rho_w V_w}\right) (Q_{HP} + Q_{QB} - Q_{rad}) \quad (9)$$

The heat output from the systems is distributed to the house via wet radiator system. The modelling of radiator system is based on simple thermodynamic equations which are related to the heat transfer physics. This term is generally can be represented as: Heat in = Heat out + Heat stored. Heated water from the heating system enters into the radiator where it drops its heat to the still fins of the radiator. After that this heat is dissipated to the room based on temperature of the radiator and heat transfer coefficient:

$$\dot{T}_{rad} = \left(\frac{1}{m_{rad} c_{rad}}\right) (Q_{in} - Q_{out}) \quad (10)$$

The gas condensing boiler for comparison with RISE system was used as part of MSc project [24] and is based on the following research papers [5], [25], [26]. The dynamics are governed by introducing a first order lag for condensing heat exchanger. The return temperature, which comes from the radiators, is lagged by thermal inertia of heat exchanger coil. In other words, while a return temperature drops across a condensing coil, the heat, which is accumulated in the condensing coil, is not able to transfer its heat instantaneously into the return temperature. A time constant of 2 minutes is used. The boiler power output depends on the efficiency  $\eta$  of the boiler as well as heat demand from the model  $\delta u(t)$ . The rate of change of the power output is modelled as follows:

$$\dot{Q}_{boiler\_GCB} = \left(\frac{1}{\tau_{GCB}}\right) (\eta u(t) - Q_{boiler}) \quad (11)$$

### C. Control System

The IDEAS framework uses an optimum start algorithm to implement a near ideal heating system control as a reference performance metric [18]. Optimum start algorithm determines the controllability of the IDEAS model in order to estimate the energy required to maintain an ideal occupancy temperature and timing profile (such as that defined by BREDEM-12 [27]). The dynamics of the whole system (building + RISE) are inverted to establish the power input and time required with respect to system time to achieve the set-point temperature. This is achieved using the RIDE theory (without integral of error feedback action) utilizing inverse dynamics such that full state feedback of the systems current state and disturbance is used in order to compensate for slow building dynamics and disturbance rejection [18]:

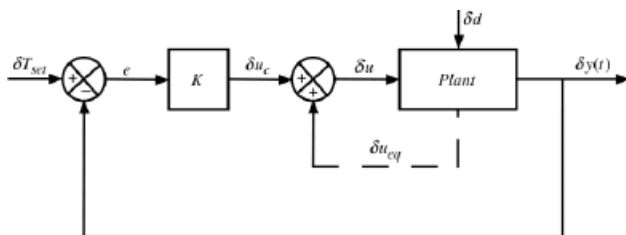

Fig. 3 RIDE/Inverse Dynamics control structure

The block diagram of the RIDE controller is shown in Fig. 3. Two control signals are used, controller input  $\delta u_c(t)$  and the equivalent signal  $\delta u_{eq}(t)$ .  $\delta u_c(t)$  depends on the error signal “e” whereas equivalent signal  $\delta u_{eq}(t)$  takes a full state-feedback of the systems present condition and disturbances. Hence this allows the control system to balance between slow dwelling dynamics as well as disturbance rejection. Signal  $\delta d$  indicates an additional heat gain/loss from different sources (i.e. radiation from sun, heat electrical devices etc.). These two control signals can be calculated as (Note: matrices D and F are assumed zero for this case in (1) and (2)):

$$\delta u_{eq}(t) = (CB)^{-1}(CA\delta x(t) + CE\delta d(t)) \quad (12)$$

$$\delta u_c(t) = Ke(t) = g(CB)^{-1}(\delta T_{set}(t) + \delta y(t)) \quad (13)$$

Where, the term  $g = 1/\tau$ ,  $\tau$  is a time constant. Hence, the energy which is needed in order to achieve a good controllability at any given step-time can be calculated as:

$$u(t) = \delta u_c(t) + \delta u_{eq}(t) + u_0 \quad (14)$$

If (12) and (13) are substituted into (1) and (2), obtained equation will be:

$$y(t) = (y_0 + \delta T_{set}(t))[1 - \exp(-gt)] \quad (15)$$

If “t”  $\rightarrow 0$ , (15) becomes:

$$y(t) = y_0 + \delta T_{set}(t) = T_{set}(t) \quad (16)$$

Hence, the output temperature will have pure tracking property without any oscillations.

The Optimum Start Algorithm is used in order to track pre-setting temperatures during occasional heat requirement periods. It can be achieved by counting additional time for heating system to switch on, in order to meet required temperature as soon as possible. For example, if requirement is 21 C at 8 o'clock in the morning, the algorithm must calculate the time for heating system to be switched in order to meet this requirement on time [18]. An extra time, which must be calculated, depends on responsiveness and capacity of the heating system (i.e. the building system time constant and its relation to the control variable). Moreover, SAP requirements and dwelling size also must be considered while doing calculations. Fig. 4 can relate to output temperature as:

$$y(t) = T_{set}(t)[1 - \exp(-t/\tau)] \quad (17)$$

From Fig. 4 it can be seen that,  $3\tau$  is needed for the system response to get and remain inside 5% of the output temperatures final value. Hence, optimum start algorithm must set back  $3\tau$  in order to reach a desired output on time.

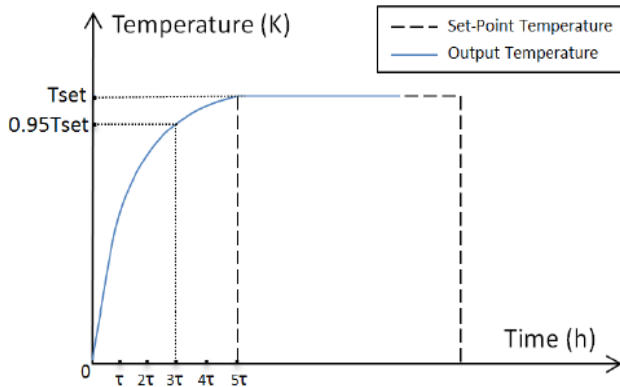

Fig. 4 Relationship between time constant and a set point temperature

#### D. Control Variable

For the RISE system the zone thermal comfort temperature was controlled specified by CIBSE [20] as operative temperature which combines air temperature and the mean radiant temperature into a single value to express their joint effect. It is a weighted average of the two, the weights depending on the heat transfer coefficient by convection and radiation at the clothed surface of the occupant. In general for insulated homes where speeds of airflow are low, the formula is half air plus half Mean radiant temperature (MRT). The reason for this will be further explained in the results as using comfort temperature would raise the overall mass temperature and thus air temperature. Considering the time period where heat pump will be off at peak times there is expected a dip in temperature and thus by controlling the comfort temperature the air temperature is raised during the interrupt time to the set-point and thus compensating for the time where the comfort temperature is not at set-point. This helps and compensates when comparing with GCB heating system where air temperature is controlled in the zone rather than comfort temperature. The RISE system was simulated for maintaining 21°C in the SAP house as illustrated in Fig. 5.

#### D. Performance Calculations

The IDEAS model allows energy assessment in the form of energy usage over a yearly period, based on the SAP file provided (data from 2008) and total cost and carbon emission calculations to be performed. These calculations can be based on two United Kingdom (UK) energy tariffs, Economy 7 and Economy 10 provided by electric utility companies. Economy 7 tariff installed in homes enables the user to take advantage of cheap electricity at night (off-peak) by operating the electrical meter in dual mode i.e. dual price rates of electricity for day and night. The day/On-peak price (p/kWh) is more expensive than the cheaper night/off-peak price (p/kWh) which lasts for seven hours and could be continuous or divided into alternative times during the night [29].

The operation of RISE is electricity based while operation of GCB is fuel (GAS) based with an addition of using electricity for control panels and switching the boiler on/off. The comparison between the two systems is made in terms of delivered heat and rather than explicit electrical energy

consumption.

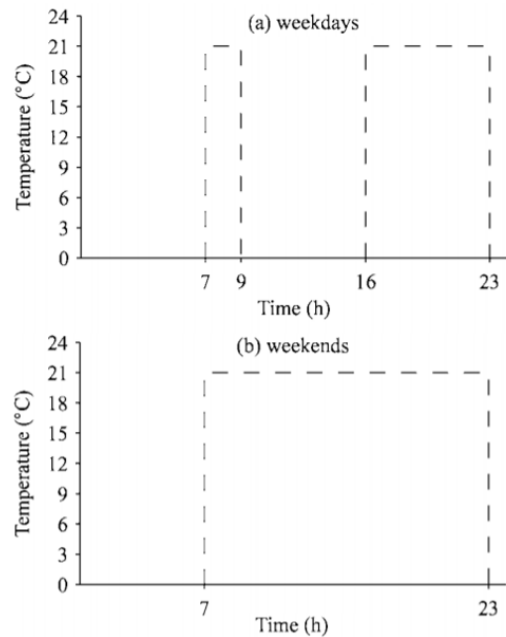

Fig. 5 Standard SAP temperature demand profile for (a) weekdays, (b) weekends [28]

The main components which use electricity in GCB are: Pump, combustion air fans and electronics. The use of electrical energy by these components might be significant, which in turn effect on the efficiency of the boiler. It is believed that, some portion of electricity returns back to the system in the form of heat [30]. For example, it is estimated that 50% of electricity which is used by electrical pumps return as heat to the water in the system. Moreover, in the air fans, it is estimated that the energy of the airflow enters the combustion chamber as heat air and contributes to the heating process. However, the case for electronics is different and can be changed from manufacturer. If the electronics are installed within or near to the boiler the components can be cooled by combustion air otherwise the electricity from electronics is considered as a loss to the system. In SAP calculations, it is assumed to suggest 175 kWh/year of electricity usage per annum for any type of boiler. However, the in-situ research which was conducted by Department of Energy and Climate Change (DECC) (now known as BEIS – department of Business Energy and Industrial Strategy) concluded that 80% of gas condensing boilers (which were monitored during one year) had much bigger electricity consumption than indicated in SAP calculations (100kWh/year-750kWh/year). Hence for this project it is assumed that over all appliances& pump power for the two systems is estimated to be identical.

Running cost and emissions of the heating systems have been calculated based on the following tariffs [31]and emission factors [32] as shown below:

TABLE II  
 FUEL PRICES EXCLUDING VAT

Fuel	Tariff	Peak p/kWh	off peak p/kWh	Emission factors
Gas	Standard	4.29	4.29	0.185
Electricity	Economy7	14.05	7.22	0.412
Electricity	Economy10	14.05	8.5	0.412

#### IV. RESULTS: RISE VS. GCB SYSTEM

The IDEAS model allowed calculation of total energy usage (kWh), total cost (£) and total carbon emissions (gCO<sub>2</sub>/kWh) to be calculated over a 365-day period based on the SAP standard dwelling data [18]. These calculations were made with RISE system to allow comparison with standard GCB system based initially on the Economy 7 Tariff.

Results show that the RISE system achieved very similar performance to a GCB system in terms of thermal comfort and running cost. The highlight for the RISE system is however, that even with today's high intensity of carbon emissions from the national grid, the RISE system showed a significant performance improvement in terms of reduced CO<sub>2</sub> emissions compared with those from a GCB. The simulated results of GCB and RISE are as follows:

The variables plotted are indicated in the legend on the plot and their description is given in the appendix. It can also be seen from the plots that the set-point profiles (black dotted line) are different in for GCB and RISE system. This is because these profiles are the optimum start profiles which are dynamically estimated according to the system time constant which affects the ramp up times as indicated by the slope.

TABLE III  
 RISE VS. GCB RESULTS

System	Cost (£/pa)	CO <sub>2</sub> (Kg/pa)	Energy (kWh/pa)	Heat (kWh/pa)
GCB	942.3	4063.6	21966 (Gas)	20406.4*
RISE	953.1	3686.4	8947.6 (Elec)	19607.8**
Δ	-10.8	377.2		798.6
Saving	-1.1%	9.3%		3.9

\* For GCB heat delivered is = energy x efficiency (0.929)

\*\* For RISE heat delivered is = energy x SPF (2.1914 RISE)

#### V. DISCUSSION AND CONCLUSION

It is believed that in coming decades the UK will see a trend towards adoption of electric heating systems for domestic heating. Gas will still be used for majority of homes for space heating and Economy 7 central-gas fired heating systems show advantage over other systems such as heat pumps etc. However due to the drive towards renewable energy, in future there will be significant contribution from hybrid or all electric heating systems supported by renewable technologies. For this changeover to happen; the hybrid/electric heating systems will need to perform better or equal to gas-fired heating systems, in terms of running cost, energy consumption and CO<sub>2</sub> emissions as well as significantly reducing capital cost and increasing efficiency.

It is a fact that the gas price (p/kWh) is lower than electricity and therefore generally an electric heating system would cost more to run than a gas heating system. However; as shown by the results the RISE system running cost is almost equal to the GCB heating system. Moreover, both systems delivered almost the same amount of heat to the house to achieve the required temperature set point. The reason for this is that, the GCB uses a large amount of kWh gas whereas RISE uses relatively small amount of kWh electricity due to quantum boiler charging at off peak times and heat utilised during peak time while keep heat pump off during peak times.

The overall running cost, heat delivered and comfort achieved by the two systems is the same. As shown in Figs. 6 and 7 the systems achieve accurate control of temperature to achieve set-point. Where the RISE doesn't track the set-point is during the interrupt period and during which the outside temperature also significantly drops and quantum boiler is not able to lift the temperature to the set-point. This could be solved by increasing the size of the quantum boiler or more efficient design of heat exchanger.

As mentioned previously this is partially compensated by a deliberate increase in air temperature and thus approximately the air temperature tracks the set-point and comparable in performance with GCB tracking of air temperature. Where RISE takes the lead over the GCB is reducing CO<sub>2</sub> emissions by 9.3%. This is significant improvement over the GCB heating system in achieving the national 2020 carbon emissions reduction targets. This difference is likely to increase significantly in favour of the heat pumps as the national grid reduces its carbon intensity towards 2030.

Currently, UK Government legislation is expected to increase its incentives for technologies such as Heat Pumps to reduce fossil fuel used to support carbon reduction. Combined Heat & Power (CHP) has been successfully used in Europe and more recently in the UK to deploy district heating at local and city levels to improve overall heat & power energy supply systems efficiency. This is an inflexible, heat-led solution unable to economically respond to constant improvements in dwelling insulation and air tightness.

A sustainable heat pump solution's efficiency increases with improvements in building performance, providing a more robust strategy to reduce carbon emissions and fuel poverty. Long term affordable and secure heat supply to UK homes is essential to off-set increasing fuel poverty and beat carbon targets. UK gas supplies are less predictable as is the future sustainability of increasing peak time electricity and a novel heat solution is urgently needed. Initial results have shown that the RISE heating system is promising.

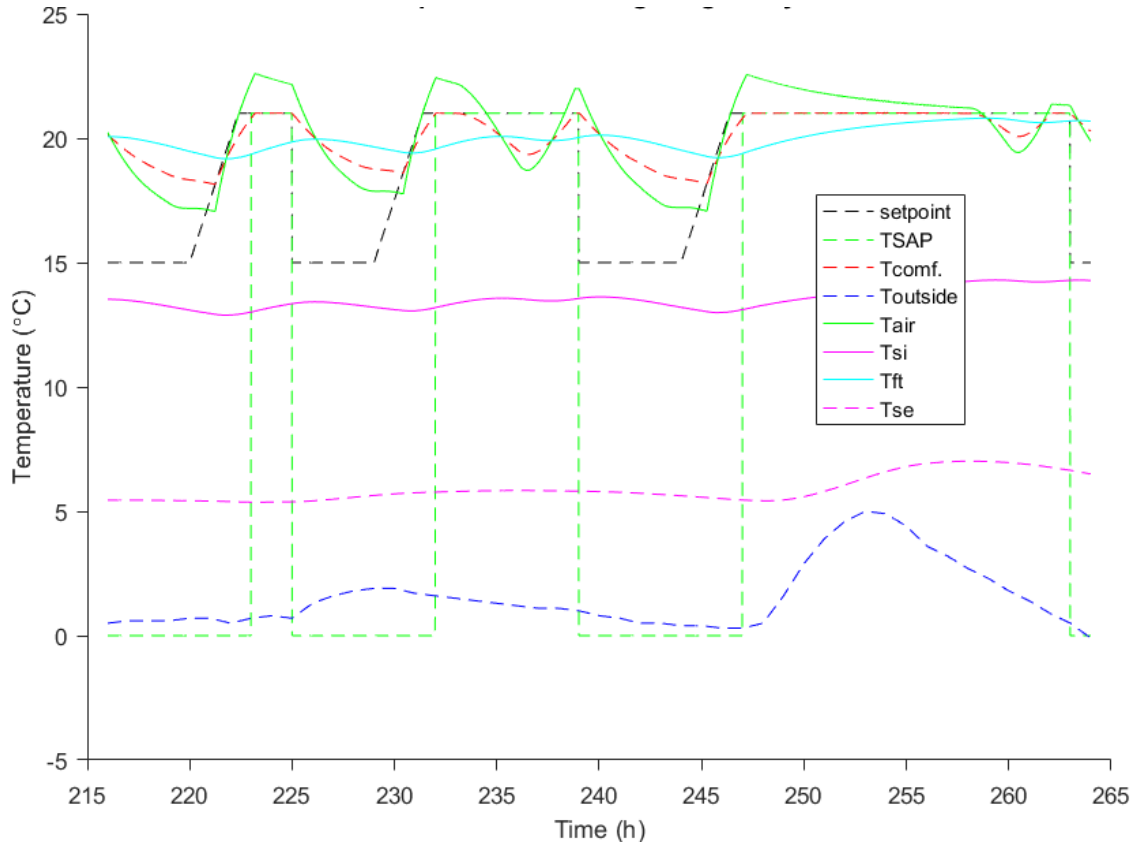

Fig. 6 Simulated result of RISE system performance

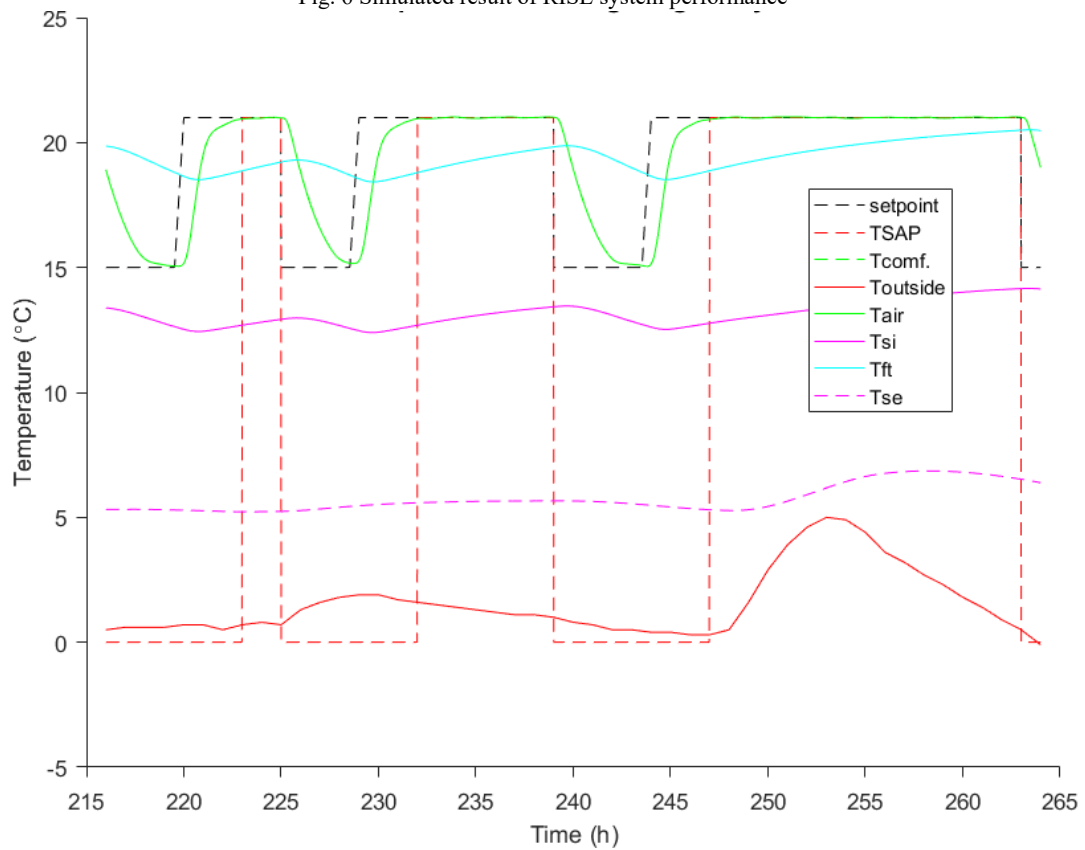

Fig. 7 Simulated result of GCB system performance

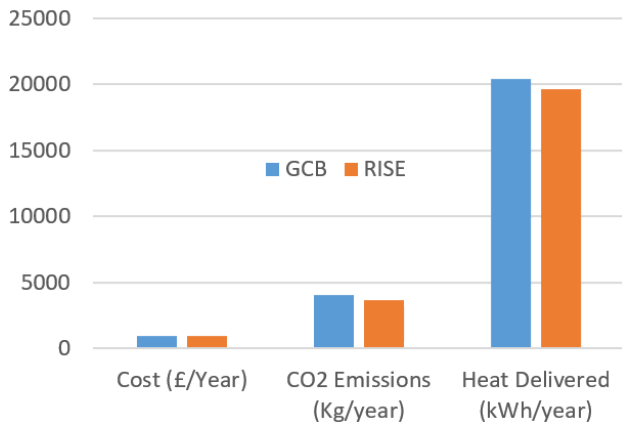

Fig. 8 RISE vs. GCB heating system performance

### VI. APPLICATION TO MICRO HEAT NETWORK

The future innovations that will enable UK economy to grow fast will contribute to energy provision that is all of the following (i.e. the energy trilemma): affordable, low carbon & secure. At present there is no economic and flexible solution to efficiently decarbonise heating of social housing multiple dwelling units (MDUs) in the UK. RISE-MDU is a promising solution with clear benefits of using an A\* rated air or ground source heat pump as an efficient, carbon competitive primary source of heating for a local heat network, topped-up with carbon competitive, off-peak electric boilers (Quantum Boiler). RISE-MDU simultaneously could meet thermal comfort needs of occupants, while matching desired electricity

supply and demand.

The RISE heating system can be readily installed in any multi-dwelling unit providing the heat loss is such that it can be met by the combined heat output capacity of the central A\* rated heat pump and the individual dwelling Quantum Boilers.

There are installation considerations relating to the housing of the centralised heat pump and the reliability of the wireless communications needed between the distributed control systems. This project will help to assess how these challenges can be resolved.

The competition for the RISE-MDU is from mini-CHP systems. There is room for both approaches in the market, but RISE-MDU has the significant advantage of not needing a gas supply to the building, is more resilient and becomes more sustainable as insulation standards and air tightness are improved in the building, either at the time of installation or in the future. The initial target markets of RISE are social housing and small hotels. The main volume market is social housing - blocks of flats, sheltered accommodation and retirement homes about 4-million units in the UK.

Finally, the ability to use a single heat pump for several small dwellings reduces capital costs per dwelling for a heat pump based system, and importantly allows the heat pump to be maintained without access to the individual dwelling. The heating system in each dwelling requires a Quantum Boiler which is almost maintenance free, enjoying the benefits of more traditional electric heating systems.

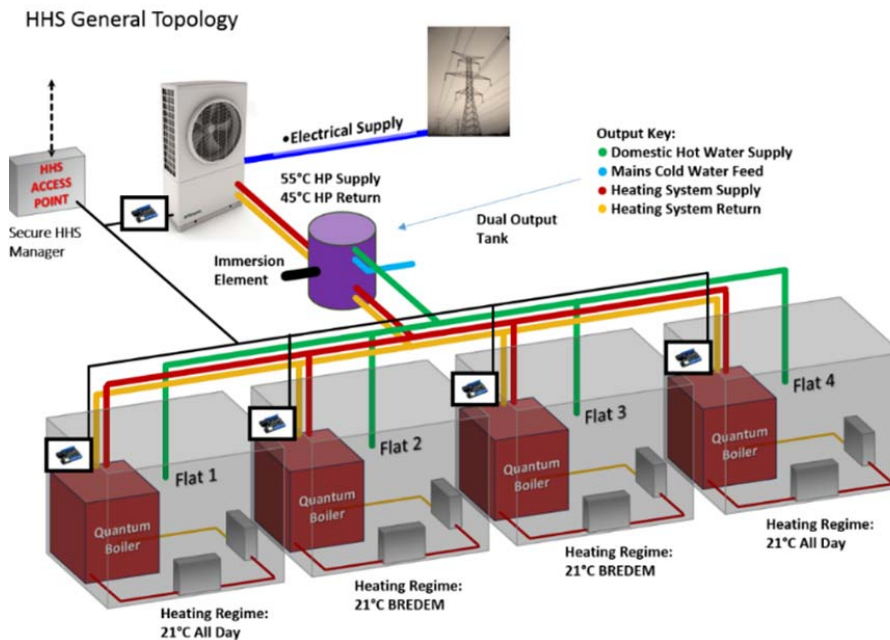

Fig. 9 Schematic of RISE Configuration for MDU

### VII. FURTHER WORK

This project has a number of areas for further work and areas of investigation for more accurate characterisation of the system performance:

- 1) The IDEAS framework is well calibrated against SAP methodology, however as the papers have shown there is still room for improvement through more accurate representation of air change rates as well as solar heat



gains. This would generate more accurate load profiles of the RISE-MDU system.

- 2) Currently the RISE prototype system is installed and is in operation. It is being monitoring for temperatures and electricity load profiles and system model validation is currently being carried out.
- 3) This paper has presented results with initial parameters of the RISE system and these need a further refinement based on the monitoring performance in the test trial.
- 4) For application to MDUs requires modelling of variable occupancy which is currently being analysed in a case study provided by East Bourne Home Ltd.
- 5) In the UK, the regions have different Energy tariffs supplied by the utility companies and currently feasibility is being carried out investigate the suitability of the system for different UK regions based on the system load profile and a number of energy tariffs. There are potential areas of the total system to be investigated for reliable performance:
- 6) The performance of the off-peak quantum boilers could start to compete with the heat pump source if the system becomes unstable so nonlinear controller design methods need to be innovated.
- 7) The high temperature hot water from the Quantum Boiler, improving thermal experience compared to traditional low temperature radiator heat pump systems, must not be returned to the heat pump system or this will adversely impact heat pump performance, reducing efficiency.

TABLE IV  
MODELLING AND SIMULATION PARAMETERS

Symbol	Parameter
$\delta, g, \tau, \eta$	Perturbation, system gain, time constant, efficiency
$x, u, d, y$	State, input, disturbance, output vectors
$A...F$	States space matrices of constant coefficients
$T_{set}$	Temperature set point
$Q, \dot{Q}$	Energy and power
$T, \dot{T}$	Temperature and rate of change
COP	Coefficient of performance
$G_c$	Heat pump compressor gain
$k_{hx}$	Heat transfer coefficient of Quantum boiler heat exchanger
$\rho$	Density
$C_p$	Mass heat capacity
$V$	Volume
$m$	Mass of radiator
$t$	Time
Subscript 0	Initial condition
Setpoint	Optimum start zone temperature set-point
TSAP	SAP required set point
Tcomf.	Comfort temperature
Toutside	External air temperature
Tair	Zone air temperature
Tsi	House external wall, internal layer temperature
Tse	House external wall, external layer temperature
Tfi	Temperature of furniture

#### ACKNOWLEDGMENT

This research project is a collaboration of industry leading partners as part of the Innovate UK research projects. In particular BRE and Glen Dimplex are given acknowledgement for providing the photos of the test rig and prototype system.

#### REFERENCES

- [1] J. Short, D. Infield, and L. Freris, "Stabilization of grid frequency through dynamic demand control," *IEEE Trans. Power Syst.*, vol. 22, no. 3, pp. 1284–1293, Aug. 2007.
- [2] Customer-Led Network Revolution, *Insight Report: Electric Vehicles*. CLNR-L092: 31<sup>st</sup> December 2014.
- [3] Customer-Led Network Revolution, *Insight Report: Domestic Heat Pumps*. CLNR-L091 Durham Energy Institute and Element Energy: 23<sup>rd</sup> January 2015.
- [4] A. Hakkaki-Fard et al, "Improving cold climate air source heat pump performance with refrigerant mixtures" *Applied Thermal Engineering*, Volume 78, 5 March 2015, Pages 695-703.
- [5] Tassou, S.A.; Marquand, C.J.; Wilson, D.R. "Energy and economic comparisons of domestic heat pumps and conventional heating systems in the British climate" *Applied Energy*, 1986, 24(2):127-138
- [6] [https://heating.mitsubishielectric.co.uk/KnowledgeBase/Public/Hybrid\\_Systems\\_Brochure.pdf](https://heating.mitsubishielectric.co.uk/KnowledgeBase/Public/Hybrid_Systems_Brochure.pdf) Accessed on: 10 July 2017
- [7] [https://www.daikin.eu/content/dam/document-library/catalogues/heat/hybrid-heat-pump/ehyhbh-av3/Daikin%20Altherma%20hybrid%20heat%20pump\\_ECPEN14-729\\_Catalogues\\_English.pdf](https://www.daikin.eu/content/dam/document-library/catalogues/heat/hybrid-heat-pump/ehyhbh-av3/Daikin%20Altherma%20hybrid%20heat%20pump_ECPEN14-729_Catalogues_English.pdf) Accessed on: 10 July 2017
- [8] B. Aspeslagh., S. Debaets, "Hybrid Heat pumps – saving energy and reducing carbon emissions", *REHVA Journal*, March 201, pages 20-25; [http://www.rehva.eu/fileadmin/REHVA\\_Journal/REHVA\\_Journal\\_2013/RJ\\_issue\\_2/p20-25\\_Hybrid\\_heat\\_pumps\\_RJ1302.pdf](http://www.rehva.eu/fileadmin/REHVA_Journal/REHVA_Journal_2013/RJ_issue_2/p20-25_Hybrid_heat_pumps_RJ1302.pdf) Accessed on: 10 July 2017
- [9] Xing-Chi. CHEN, "Air Source Heat Pump Energy Storage Heating System for Smart Building" 2016 28<sup>th</sup> Chinese Control and Decision Conference (CCDC).
- [10] A.Hesaraki et al, Seasonal thermal energy storage with heat pumps and low temperatures in building projects – A Comparative review. *Renewable and Sustainable Energy Review*, Volume 43, March 2015, pages 1199–1213.
- [11] Book, "2016 implementing the Energy Performance of Buildings Directive (EPBD)" Lisbon, September 2015 ISBN 978-972-8646-32-5 <http://www.epbd-ca.eu/outcomes/2011-2015/CA3-BOOK-2016-A-web.pdf>
- [12] J. Wang, "UK Building Regulations, Department for Communities and Local Government, Planning Development Documents-Collections", <https://www.gov.uk/government/collections/approved-documents> Accessed on 21 April 2016
- [13] BRE Standard Assessment Procedure (SAP), <http://www.bre.co.uk/sap2012/>
- [14] BRE Simplified Building Energy Model (SBEM), [www.uk-ncm.org.uk/](http://www.uk-ncm.org.uk/) Accessed on: 17th March 2017
- [15] DCLG approved national calculation methodologies and software programs for buildings other than dwellings, <https://www.gov.uk/government/publications/department-for-communities-and-local-government-approved-software-for-the-production-of-non-domestic-energy-performance-certificates-epc> Accessed on :31 October 2014
- [16] Counsell, J.M., Murphy G.B., Allison J. "Control of micro-CHP and thermal energy storage for minimising electrical grid utilisation", *International Journal of Low-Carbon Technologies Advance Access published August 21, 2014*
- [17] Counsell, J.M., Ameer, K., Stewart, M., 'CHPV Control'. IET Faraday Workshop, Calcutta India, 2015. Online: At IET Conferences.
- [18] Murphy, G.B., Counsell, J.M., et al "Calibrating a combined energy systems analysis and controller design method with empirical data", *Elsevier journal "Energy"*, Vol 57, pp484-494, August 2013
- [19] National Calculation Methodology, online resource hub, <http://www.uk-ncm.org.uk/> Accessed on 1st March 2017
- [20] CIBSE Guide A: Environmental Design 2015, ISBN: 9781906846541, 2015
- [21] CIBSE Weather Data Sets, <http://www.cibse.org/knowledge/cibse-other-publications/cibse-weather-data-sets> Accessed on 1st March 2017
- [22] G. Murphy, J. Counsell, E. Baster; et al "Symbolic modelling and predictive assessment of air source heat pumps" *Building Services Engineering Research and Technology*; Volume 34, issue 1, pages 23-39, 2012
- [23] Murphy. GB, Baster. E, Allison. J, Counsell. S; "Simplified Modelling of air source heat pumps producing detailed results", *CIBSE technical Symposium, Imperial College, London UK, 18<sup>th</sup> – 19<sup>th</sup> April 2012*
- [24] Z. Abdullayev; "Comparison studies of domestic space heating systems

- using IDEAS dynamic house model (Gas Condensing Boiler vs Air Source Heat Pump”, University of Liverpool, School of Electrical Engineering and Electronics, MSc Project Thesis, September 11, 2015
- [25] V.L.Hanby; “Modelling the performance of condensing boilers”, Journal of the Energy Institute, Vol. 80, Iss.4, 2007
- [26] V.L.Hanby& G. Li; “Modelling the thermal and Emissions Performance of Commercial Boilers”, HVAC&R Research, 3:2, 101-111, 2011
- [27] J. Henderson & J. Hart; BREDEM 2012 – A technical description of the BRE domestic energy model, 2015, [www.brebookshop.com](http://www.brebookshop.com)
- [28] Murphy. GB, Allison. J, Monari. F; “Determining the effect of weather data upon building simulation in regulatory processes” Proceedings of BS2013, 13<sup>th</sup> Conference of international building performance simulation association, Chambéry, France, August 26-28
- [29] P.J.Boait et al, “Making legacy thermal storage heating fit for the smart grid”, Energy and Buildings 138 (2017) 630-640
- [30] Georgina O., Tom L., Simon B., “Final report: Insitu monitoring of efficiencies of condensing boilers an use of secondary heating,”
- [31] Energy saving trust average price <http://www.energysavingtrust.org.uk/about-us/our-calculations> Accessed on :5 October 2016
- [32] Greenhouse gas reporting conversion factors 2016 <https://www.gov.uk/government/publications/greenhouse-gas-reporting-conversion-factors-2016> Accessed on :5 October 2016