

Cardiovascular Modeling Software Tools in Medicine

J. Fernandez, R. Fernandez de Canete, J. Perea-Paizal, J. C. Ramos-Diaz

Abstract—The high prevalence of cardiovascular diseases has provoked a raising interest in the development of mathematical models in order to evaluate the cardiovascular function both under physiological and pathological conditions. In this paper, a physical model of the cardiovascular system with intrinsic regulation is presented and implemented by using the object-oriented Modelica simulation software tools. For this task, a multi-compartmental system previously validated with physiological data has been built, based on the interconnection of cardiovascular elements such as resistances, capacitances and pumping among others, by following an electrohydraulic analogy. The results obtained under both physiological and pathological scenarios provide an easy interpretative key to analyze the hemodynamic behavior of the patient. The described approach represents a valuable tool in the teaching of physiology for graduate medical and nursing students among others.

Keywords—Cardiovascular system, Modelica simulation software, physical modeling, teaching tool.

I. INTRODUCTION

CARDIOVASCULAR modeling presents a particular challenge due to the highly nonlinear characteristics of this physiological system and entails a multi-domain approach since hydraulics, electrical, and chemical dynamics are combined to define the complete system behavior [1]. Several mathematical models of the cardiovascular system have been described in scientific publications [2]-[4], and different simulation software has appeared to help the clinician the understanding of the underlying processes which explain the operation of the cardiovascular system under both physiological and pathological conditions [5], [6].

Mathematical models in physiology follow the causal approach [7], traditionally presented by either employing a set of differential and algebraic equations or else by using a block diagram representation between the interconnections of simpler subsystems as Simulink [8], far apart from the common representation of physiological knowledge.

In contrast, the acausal modelling approach can offer many advantages in physiological system modelling when dynamics are given as a set of individual components interconnected so as to describe the inherent structure of the physical system [9] as it happens with the Modelica object-oriented approach [10], suitable to describe system, subsystem, and component levels of a whole physical system with increasing detail.

J. Fernandez is with the System Engineering and Automation Dpt. University of Malaga, Spain (e-mail: ffernandezr@uma.es).

R. Fernandez de Canete collaborates with the System Engineering and Automation Dpt, University of Malaga, Spain (e-mail: canete17@gmail.com).

J. Perea.Paizal collaborates with the System Engineering and Automation Dpt. University of Malaga, Spain (e-mail: julia_iriial@hotmail.com).

J. C. Ramos-Diaz is with Pediatric Service, Antequera District Hospital, Malaga, Spain (e-mail: juancarlosramosdiaz@hotmail.com).

In this paper, we describe the use of the Modelica object-oriented modelling language for the acausal modelling of the cardiovascular system, where a multi-compartmental system constituted by arterial circuit, venous circuit, and heart pump under Frank-Starling regulation mechanism has been employed to characterize the cardiovascular dynamics. Results obtained during simulation both in normal and abnormal physiological conditions provide an interpretative key for the clinician to understand easily the patient cardiovascular dynamics.

II. MODELING OF THE CARDIOVASCULAR SYSTEM

The cardiovascular system under study will be described by seven compartments, namely two cardiac chambers, aorta, arterial and venous systemic circulation, and arterial and venous pulmonary circulation, all resulting into a nonlinear set of differential equations as referred in [11] whose schematic diagram is depicted in Fig. 1.

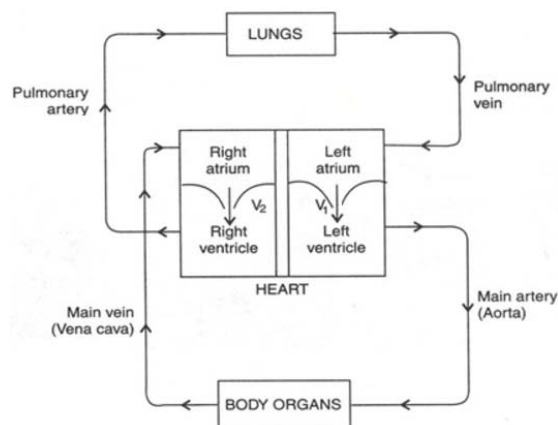

Fig. 1 Scheme of compartmental model of cardiovascular system

An electrical analogy model has been derived taking into account the similarity between the electrical equations of the RC circuit below and each of the vascular compartments, distinguishing between linear and non-linear (with valves) compartments (Fig. 2).

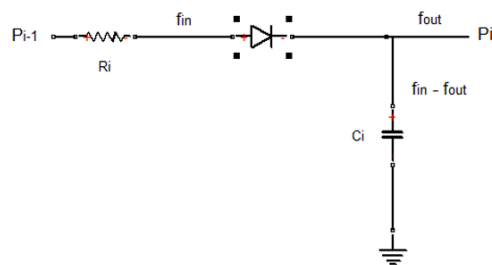

Fig. 2 Electrical analogy of cardiovascular compartment

Therefore, each component of the cardiovascular system in spite of its hydraulic nature will be characterized by an RC electrical component with (valve) or without diode, described by the set of equations

$$\frac{dV_i(t)}{dt} = f_{in}(t) - f_{out}(t) \quad (1)$$

$$P_i(t) = \frac{V_i(t)}{C_i} \quad (2)$$

$$f_{in}(t) = \frac{1}{R_i} \max(P_{i-1}(t) - P_i(t), 0) \quad (\text{valve}) \quad (3)$$

$$f_{in}(t) = \frac{P_{i-1}(t) - P_i(t)}{R_i} \quad (4)$$

where $f_{in}(t)$ is the input flow rate, $f_{out}(t)$ is the output flow rate, $P_i(t)$ is internal pressure relative to the i^{th} compartment the i^{th} compartment, while C_i and R_i stand for compliance and resistance. The heart contraction and ejection processes are described in each ventricle according to variable elastances $C_{LV}(t)$ and $C_{RV}(t)$ as explicated described in [11].

III. THE MODELICA SIMULATION ENVIRONMENT

The simulation software here used is Modelica which is an object-oriented language for modeling and simulation of complex physical systems in general, endowed with a multi-domain modeling capability, so that several different physical domains can be used and interconnected [10]. Modelica contains different physical components libraries ranging from electrical, mechanical, hydraulic, and many others.

In comparison to traditional block-oriented simulation tools as Simulink [8], Modelica is based on defining special-purpose class connectors so as model variables are shared with other sub-models, thus no computational order is strictly followed. Then, connections are thought of as one of the main features of the oriented-object modeling principle, so model reuse is allowed.

In Modelica, the system under analysis is decomposed into single components starting from the bottom up, connecting basic components into more complicated ones, until the top-level model is reached. It enables use of alternate integration method as is the DASSL, Runge-Kutta, and Backward Difference based.

The cardiovascular system under study was simulated using Modelica starting from the seven connected compartments of the circulatory system under Frank-Starling homeostatic control mechanism. The Modelica block diagram of the complete multi-compartmental system is illustrated in Fig. 3, where the closed loop cardiovascular system with the two distinct pulmonary and system circuits connected through the ventricles modeling of the heart pump can be seen. It is important to highlight the use of the electrohydraulic analogy so that vascular resistances, compliances, and valves have been represented as electric resistors, capacitances and diodes, along with the analogy relation between pressure and flow and the corresponding voltage and current. Besides, a pair of variable compliances has been included to generate the cyclic behavior so as to simulate the pumping function.

Open Science Index, Bioengineering and Life Sciences Vol:11, No:9, 2017 publications.waset.org/10008091.pdf

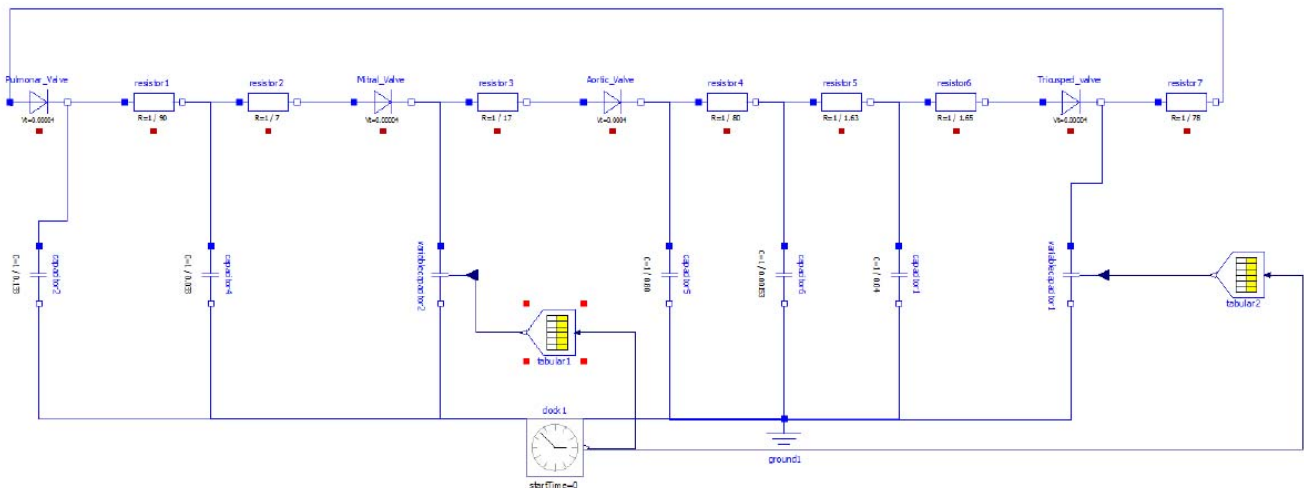

Fig. 3 Modelica diagram of the cardiovascular system

Due the inheritance property of Modelica which enables reuse of blocks, it is only necessary to design a component (RC circuit) and change its parameters to model each of the vascular components, connecting them afterwards to set the closed circuit. In Fig. 4, it has been included for the sake of comparison the Simulink diagram corresponding to the same system. We observe the complexity of this block-diagram

causal approach as compared to the simplicity of the physical acausal modeling approach.

IV. SIMULATION RESULTS

Several experiences have been realized so as to test the performance of the cardiovascular system model, both under physiologic and pathological conditions as aortic stenosis and

cava relaxation. In order to get the simulation results, validation tests have been previously performed with physiological data as referred in [11]. In first place, in Fig. 5, the results obtained with the Modelica model under physiological conditions are shown, where the cyclic behavior of cardiovascular variables as pressure in different compartments can be seen. In the second place, the value of the aortic resistance has been doubled so an increase in the aortic pressure among others can be observed as shown in Fig. 6.

Finally, a case of cava relaxation has also been included, so it can notice how and where a reduced cava pressure vale is observed as detailed in Fig. 7.

V. CONCLUSION

Modeling software tools have been presented in this paper, in particular the object-oriented modeling approach of Modelica and a closed loop cardiovascular system model has been developed by using this particular acausal approach.

The Modelica model structure is organized as interconnected components so that the system equations are embedded in the connection diagram. Besides, the model structure resembles the physical reality of the modeled system as compared to block diagram scheme in Simulink. The modeling effort is thus considerably reduced while reuse of components is enabled thanks to the inheritance property of Modelica.

Simulation models are more understandable in Modelica so it can be considered as a valuable educational tool in Physiology.

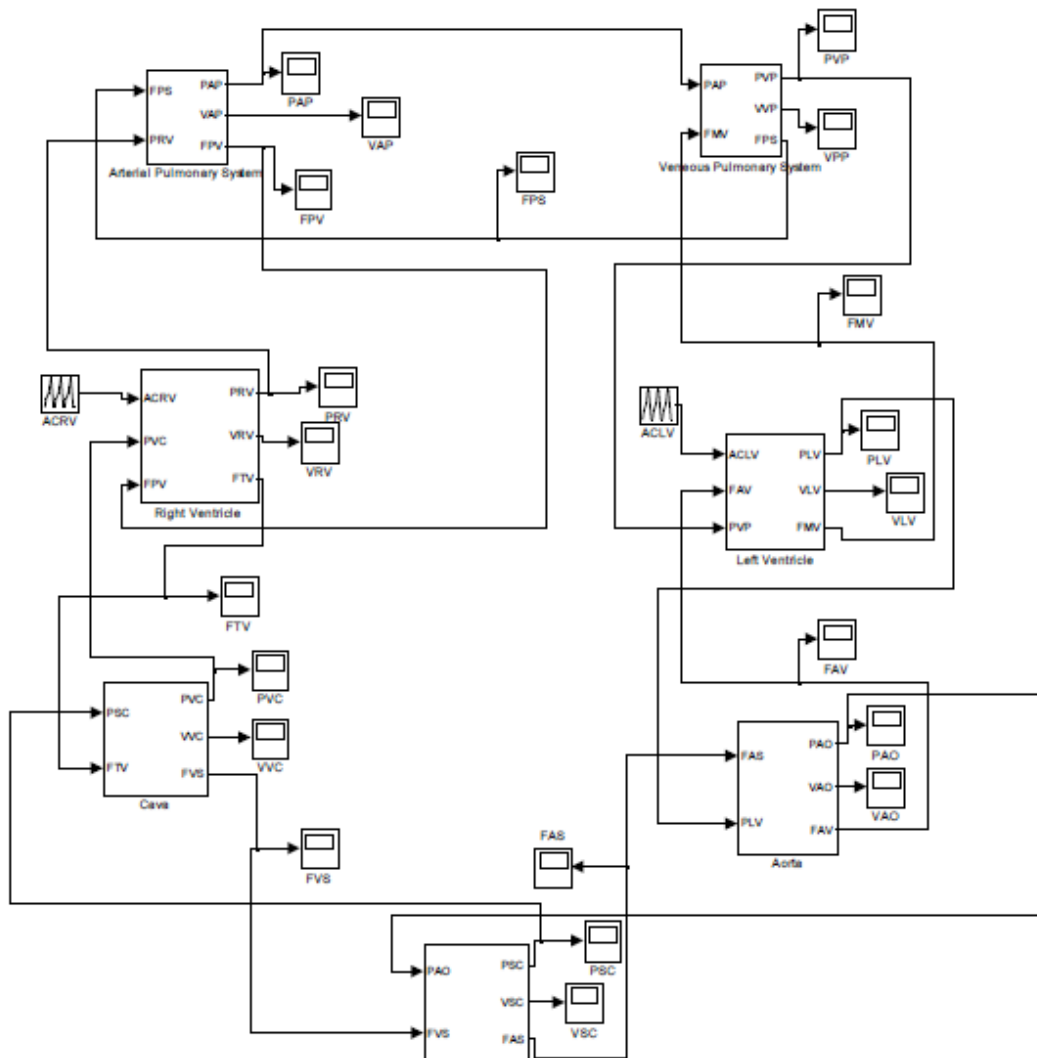

Fig. 4 Simulink diagram of the cardiovascular system

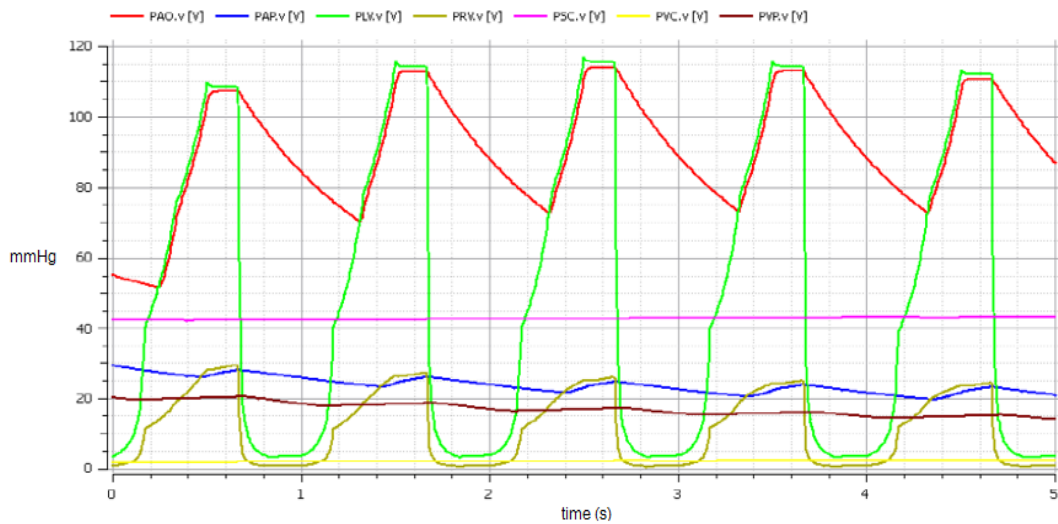

Fig. 5 Pressure evolution in different compartments (see color code above) under physiological conditions in Modelica

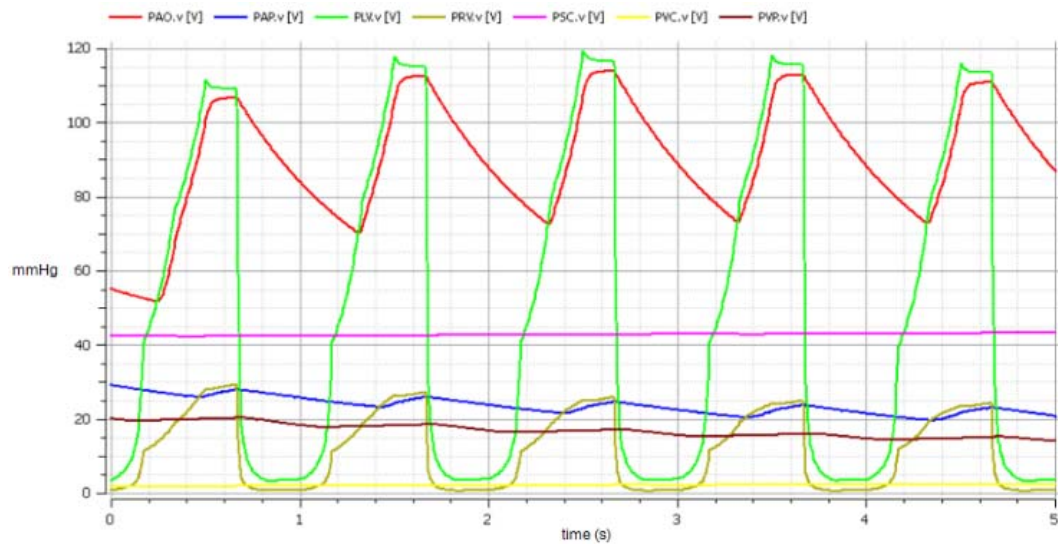

Fig. 6 Pressure evolution in different compartments (see color code above) under aortic stenosis conditions in Modelica

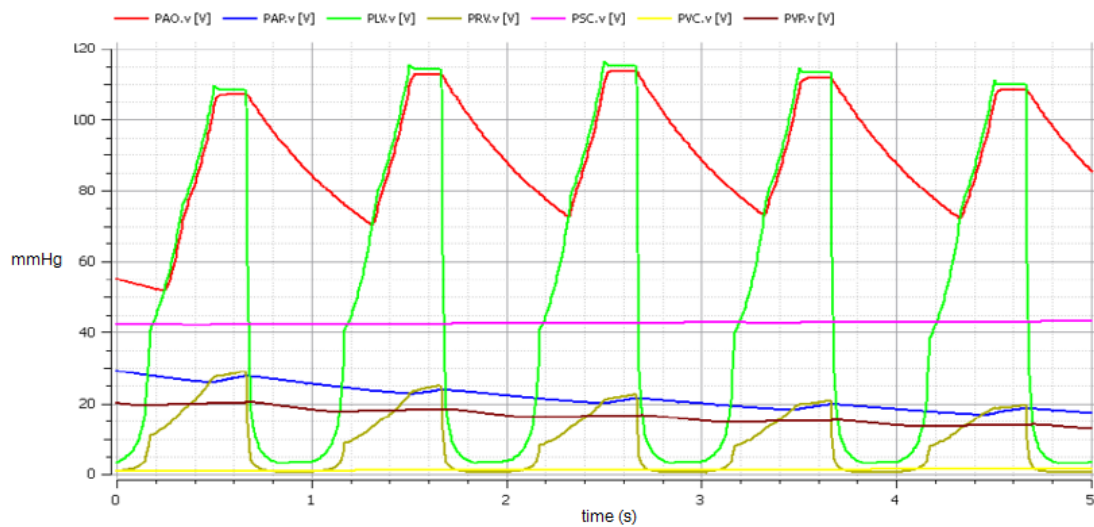

Fig. 7 Pressure evolution in different compartments (see color code above) under cava relaxation conditions in Modelica

REFERENCES

- [1] A. C. Guyton, J. E. Hall, Textbook of Medical Physiology, ninth ed., W.B. Saunders, New York, NY, 1996.
- [2] E. B. Shim, J. Y. Sah, C. H. Youn, "Mathematical modeling of cardiovascular system dynamics using a lumped parameter method", Jpn J Physiol., vol. 54(6), 2004, pp. 545-553.
- [3] M. J. Conlon, D. L. Russell, T. Mussivand, "Development of a mathematical model of the human circulatory system", Ann Biomed Eng., vol. 34(9), 2006, pp. 400-413.
- [4] M. Abdolrazaghi, M. Navidbakhsh, K. Hassani, "Mathematical modelling and electrical analog equivalent of the human cardiovascular system", Cardiovasc Eng., vol. 10(2), 2010, pp. 45-51.
- [5] A. Brunberg, S. Heinke, J. Spillner, R. Autschbach, D. Abel, S. Leonhardt, "Modeling and simulation of the cardiovascular system: a review of applications, methods, and potentials", Biomed Tech, vol. 54(5), 2009, pp. 233-244.
- [6] C. De Lazzari, I. Genuini, D.M. Pisanelli, A. D'Ambrosi, F. Fedele, "Interactive simulator for e-Learning environments: A teaching software for health care professionals", Biomed Eng. Online vol. 13, 2014, pp. 172-191.
- [7] J. Kofranek, J. Ruzs, "Restoration of Guyton's diagram for regulation of the circulation as a basis for quantitative physiological model development", Physiol. Res, vol. 59, 2010, pp. 897-908.
- [8] S. T. Harris, *Introduction to Simulink: With Engineering Applications*, Orchard Publications, 2008.
- [9] G. Zauner, D. Leitner, F. Breitenecker, "Modeling structural dynamic systems in Modelica/Dymola, Modelica/Mosilab and AnyLogic", in: *Proceedings of the International Workshop on Equation-Based Oriented Languages and Tools*, 2007.
- [10] P. Fritzson, *Introduction to Modeling and Simulation of Technical and Physical Systems with Modelica*, Wiley-IEEE Press, 2011.
- [11] Avanzolini G, Barbini P, Cappello A, Cevenini G (1988). CACDS simulation of the closed-loop cardiovascular system. Int. J. Biomed. Comput. 22:39-49.