

Simulation and Experimental Research on Pocketing Operation for Toolpath Optimization in CNC Milling

Rakesh Prajapati, Purvik Patel, Avadhoot Rajurkar

Abstract—Nowadays, manufacturing industries augment their production lines with modern machining centers backed by CAM software. Several attempts are being made to cut down the programming time for machining complex geometries. Special programs/software have been developed to generate the digital numerical data and to prepare NC programs by using suitable post-processors for different machines. By selecting the tools and manufacturing process then applying tool paths and NC program are generated. More and more complex mechanical parts that earlier were being cast and assembled/manufactured by other processes are now being machined. Majority of these parts require lots of pocketing operations and find their applications in die and mold, turbo machinery, aircraft, nuclear, defense etc. Pocketing operations involve removal of large quantity of material from the metal surface. The modeling of warm cast and clamping a piece of food processing parts which the used of Pro-E and MasterCAM® software. Pocketing operation has been specifically chosen for toolpath optimization. Then after apply Pocketing toolpath, Multi Tool Selection and Reduce Air Time give the results of software simulation time and experimental machining time.

Keywords—Toolpath, part program, optimization, pocket.

I. INTRODUCTION

IN today's fast growing manufacturing sector, applications of proper simulation, modeling and optimization strategies in metal cutting is essential to improve the machining and overall productivity and milling process is widely used in industry including the aerospace and automotive sectors because of its versatility and efficiency. CAM module makes universal, standard NC code, which is further translated (post-processed) into a form, which is understood by specific machine controllers. Each machine controller has specific post-processor, which transforms different code formats [1].

The advantages produced by the use of solid modeling instead of surfaces must be considered. Thus, a part modeled as a solid closes a certain volume, so that the zones in which material may be present can be easily defined. There are three stages in the generation of CAM cutting paths, according to the type of operation: (a) roughing, (b) semi finishing and (c) finishing [2]. More than 80% of all mechanical parts which are manufactured by milling machines can be cut by NC pocket

Rakesh Prajapati is with the Faculty of Engineering & Technology for Parul University, Vadodara, Gujarat, India (phone: +91-8141666880; e-mail: rakeshkumar.prajapati@paruluniversity.ac.in).

Purvik Patel is with the Faculty of Engineering & Technology for Parul University, Vadodara, Gujarat, India (phone: +91-8140625272, e-mail: purvikr@gmail.com).

Avadhoot Rajurkar is with the Department of Industrial & Production Engineering, Vishwakarma Institute of Technology, Bibwewadi, Pune, Maharashtra, India (e-mail: aviraj.vitpune@gmail.com).

machining. This is based on the fact that most mechanical parts consist of faces parallel or normal to a single plane and that free-form objects are usually produced from a raw stock by 2.5D roughing and 3D-5D finishing. In order to generate optimum tool paths for pocket milling, cutting forces and radial depth of cut maintained under reference values must be required in the entire machining area [3].

The pocketing operation particularly relates to the manufacturing industry. The main objective is to reduce the toolpath length ultimately to reduce the machining time. It is possible to either decrease the length of the tool path or increase the instantaneous feedrate of the tool. The tool path presents a set of circle arcs (continuities) at each corner in tangency located at the radial tool path linking. NC toolpath should be smooth and steady as possible to guarantee the machining quality and to protect the spindle [4].

II. TOOL SELECTION AND CUTTING PARAMETER

Selection of Tool and Cutting Parameter is as per machining operations on chosen application. The different factor is affecting for selection of tool and cutting parameter. Tool is selected to availability of Cutting Tools on ATC of VMC which is shown in Table I. On a 3-axis CNC machining centre, pocketing operations are typically performed using a flat end-mill. After selection of tool, cutting parameters are under taken from standard data of milling operation. Today, many approaches that take into account one or several criteria (production cost, production time, productivity, machining accuracy, etc.) are being developed to optimize certain cutting parameters (cutting speed, feed rate, depth of cut, stepover, etc.) [5]. The Solid Carbide tool of 12 mm Diameter and HSS tool of 6 mm Diameter used for removing material.

The time required for machining a desired feature on a computer numerically controlled (CNC) machining centre depends on a number of factors including the machine characteristics, machining strategy, the chosen cutting-tool types and sizes, the geometry of the feature and tolerance specifications, and machining process parameters [6]. The important factors in process planning for pocket machining are: cutting-tool diameter selection, tool-path planning, the distance between tool-paths called the stepover. Also worth noting is machining time calculation, as well as other things such as: spindle speed and feed rate. From the above factors, cutting-tool diameter is the most important factor because the other factors depend on it [7].

TABLE I
 CUTTING PARAMETER FOR POCKETING OPERATION

Sr. No	Cutting Tool Parameter	12 mm Diameter Solid Carbide	6mm Diameter HSS	Workpiece Material
1	Spindle Speed	1000	1400	Aluminum 2024
2	Feed	299	209	Aluminum 2024
3	Depth of Cut	2	2	Aluminum 2024
4	Step over (%)	75	75	Aluminum 2024

III. TOOLPATH GENERATION METHODS

Ideally, toolpath should be formed by connecting the cutter trajectories continuously without non-cutting moves. However, this is often impossible for the cases with complex part geometry or islands. Hence, it is necessary to plan the toolpath. There are two toolpaths that satisfying minimum machining time [8]. Although there are many possible ways of planning a tool path in pocket-milling operation, direction parallel (or zig-zag or staircase) and contour parallel (spiral) milling, have been the two standard procedures practiced [9].

The contour-parallel toolpath comprises of a series of contours that are parallel to the boundary of the 2D cross-section. Whereas, direction-parallel path is the path segments correspond to back and forth motion in a fixed direction within the boundary of the 2D cross-section [8]. Fig. 1 (a) illustrates direction parallel (zig-zag) method and Fig. 1 (b) explains that of contour parallel milling method.

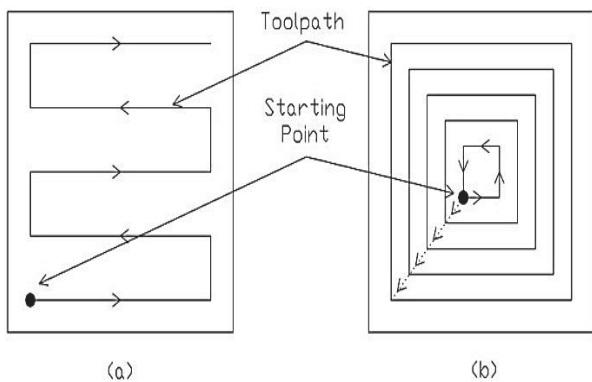

Fig. 1 Toolpath Generation Methods

The further classified different toolpath generation available in MasterCAM® discussed in Fig. 1, they are zigzag, Constant Overlap Spiral, Parallel Spiral, Parallel Spiral Clean Corners, Morph Spiral, High Speed, One Way and True Spiral. High Speed is not considered in Simulation and Experiment. Green line presents pocket boundary and blue line presents toolpath of pocketing operation.

IV. OPTIMIZATION TECHNIQUES

Toolpath Optimization techniques are describing in two strategies. The first strategy communicates with MasterCAM® software for reduction in machining time by optimization of tool path using CAD/CAM simulation. The second strategy

requires selection of optimal cutting parameters for pocket milling process.

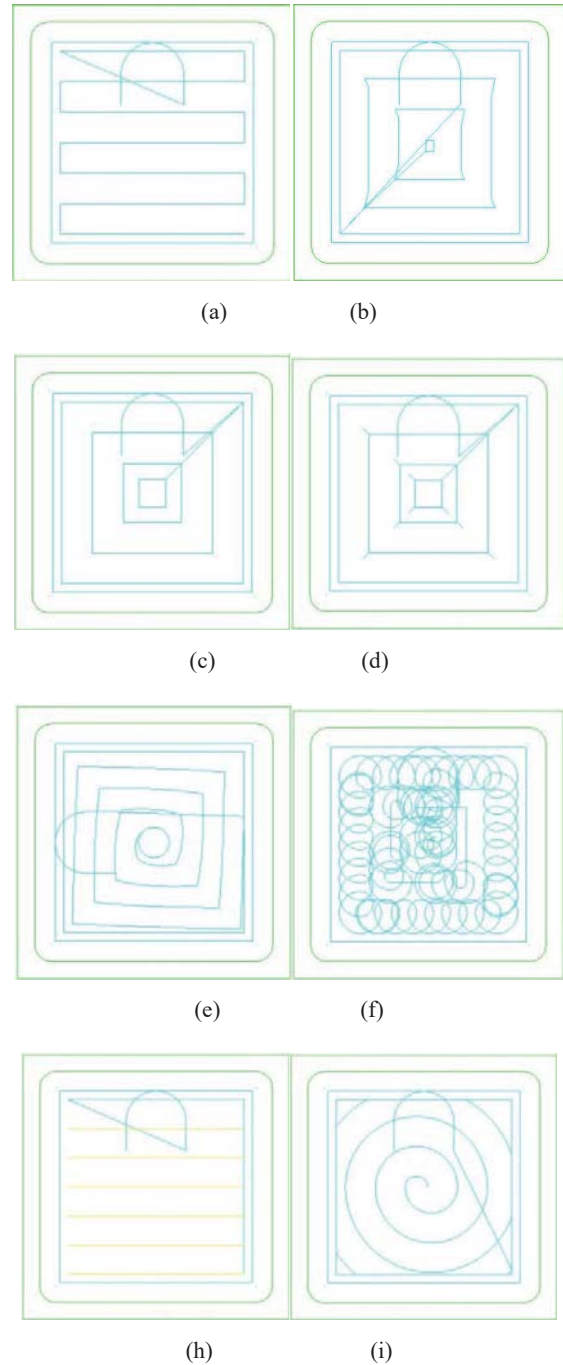

Fig. 2 Toolpath Generation Methods (a) Zigzag Toolpath, (b) Constant Overlap Spiral, (c) Parallel Spiral, (d) Parallel Spiral Clean Corners, (e) Morph Spiral, (f) High Speed, (g) One Way, and (i) True Spiral

Below are different techniques of pocketing toolpath optimization.

- 1) Automatic Tool-Change
- 2) Feedrate Optimization
- 3) Rapid Movement

- 4) Reducing Cusp
- 5) Applying Different Toolpath
- 6) Combination of Toolpath
- 7) Multi Tool Selection
- 8) Reduce Air Time
- 9) Varying Different Cutting Parameters

The mind-set of single tool selection has been reinforced by the fact that many early generation CNC machines require manual time consuming loading and set-up of cutting-tool in the spindle. But with the availability of automatically tool change mechanism in modern CNC machining centre called automatic tool-change (ATC) that is capable of rapid turnover cutting-tool, then the above objectives become irrelevant [7].

Software modules like dynamic feed rate optimization and high speed machining can shorten the NC program and reduce machining time. Dynamic feed rate optimization module enables the feed decrease as the tool cuts more material and increases as the tool cuts less material. Similar to federate optimization is smart cornering, which adjusts the feed rate around corners and small radii for smooth transition in tight areas based on the part and machine tool characteristics [1].

In actual machining, the tool is moving rapidly when there is no feed rate needed. Direction parallel tool paths, also commonly referred to as Zig-zag machining, are not preferred for features with hard boundaries because cusps are left behind along the hard edges during rough machining; the removal of these cusps requires an extra pass thus increasing the total tool path length. They identified a corner uncut area occurring at a sharp corner, a centre uncut area occurring at the centre of an innermost contour parallel offset curve, and a neck uncut area occurring in a region where the next level tool paths split

V. SIMULATION AND EXPERIMENTAL

The proposed design of toolpath optimization indicates Detail drawing of specific application, modeling and simulation of toolpath with post process. A proper application related to pocketing operation is chosen from industries which is performed on VMC and efficient in MasterCAM® X3. There have been visited industries such as Indo German Tool Room, MAN Turbo India Pvt. Ltd., Flovel Valves Pvt. Ltd. and Yantra Kaushalya Pvt. Ltd. for select the applications. In this research work, mainly two applications are performed which are based on food processing. The Detail drawing of Warm cast and Clamping piece has been got from Yantra Kaushalya Pvt. Ltd. The applications are shown in Figs. 3 and 4. In first application there is only inner pocket. In second application there are inner and outer pocket. Here the inner pocket is chosen as a working process which is suitable for experiments.

A. Modeling of Application

The application is modeled with the use of Pro-Engineer Wildfire 5.0 and MasterCAM® X3. The complex application is modeled in Pro-Engineer Wildfire 5.0 and imported into MasterCAM® X3 as IGES, VDA, STEP, STL, etc. Modeling of Warm cast and Clamping piece are done by Pro-Engineer Wildfire 5.0 and saved as IGES file which are shown in Figs.

5 and 7 respectively. These IGES files are imported into MasterCAM® X3 for simulation of operation which is shown in Figs. 6 and 8 respectively.

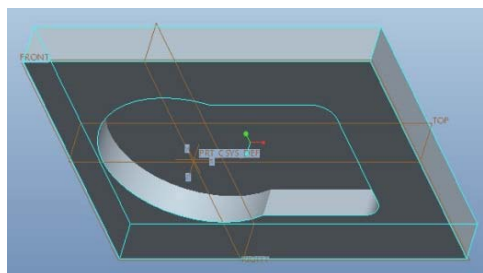

Fig. 3 Warm cast of Food Processing modeling in PRO-Engineer Wildfire 5.0

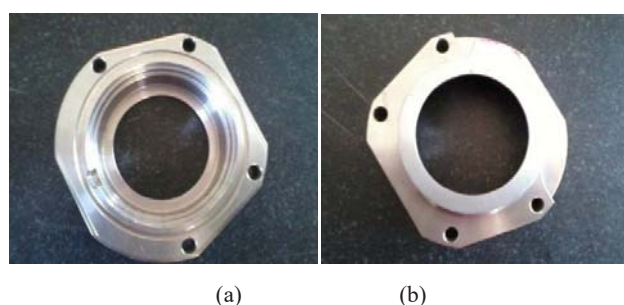

Fig. 4 Clamping Piece of Food Processing (a) Top View and (b) Bottom View

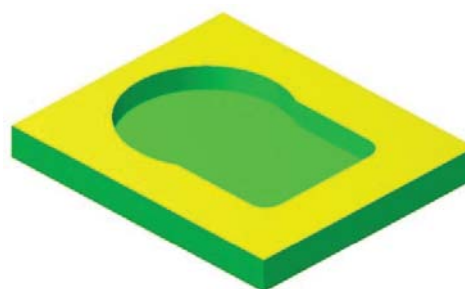

Fig. 5 Warm cast model in Master CAM® X3

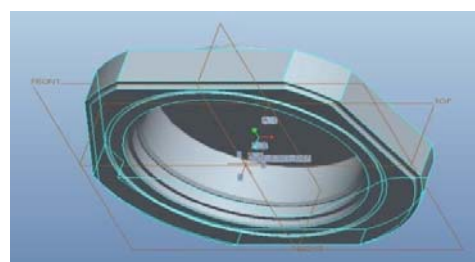

Fig. 6 Model of Clamping Piece in PRO-Engineer Wildfire 5.0



Fig. 7 Model of Clamping Piece in Master CAM® X3

B. Simulation of Warm Cast and Clamping Piece

Before simulation of toolpath, the entities of model are clearly mentioned for chain selection. After that the operations are applied for toolpath simulation. Verifying process is carried out for advocating the completely removal of material in machining simulation process. Back plot is used to show how toolpath follows the steps in MasterCAM® X3. It also gives Cycle Time and Path Length which is shown in Figs. 9 and 10.

The simulation of different toolpath is done for Clamping piece and they give Toolpath Length and Machining Time during the simulation. CAM software is utilized to generate NC part program for different types of controller. From the optimization result, the program of Optimize Toolpath is generated by post processing in Master CAM® X3. These NC part programs are imported into 3-axis Vertical Machining Centre for actual machining via USB port and actual experiment is carried out.

C. Experimental Set-Up

PX Series 3-axis Vertical Machining Centre has been developed with the aim to deliver ability to cope up with various areas of demanding manufacturing industry. In addition to using such programs, manufacturing knowledge is needed to specify parameters such as feed rate, depth of cut, cutting speed and stepover. The stock is ready for the experiment by facing operation. The stock material for warm cast component is aluminum and its dimensions are $170 \times 142.64 \times 20$. The stock material for clamping piece is Aluminum and its dimensions are $100 \times 100 \times 25$. The work piece Co-ordinate System is to be set before machining a part with the help of Probe. The work piece's co-ordinate is set as origin $(x, y, z) = (0, 0, 0)$.

From the optimized result, the program of Parallel Spiral Clean Corners and Zigzag are generated by post processing in MasterCAM® X3. This program is imported in 3-axis VMC for carried out Experiment result with the help of USB Pen drive. The actual machining is focusing after simulation of toolpath optimization for food processing parts. Food processing parts are made with the use of pocketing operation. Best one optimizes toolpath select for actual machining. The machined part is shown in Figs. 10 and 11 after machining. There is measurement of machining time during the actual machining. This actual machining time is compared with simulation time. Actual machining gives also complete time of machining.

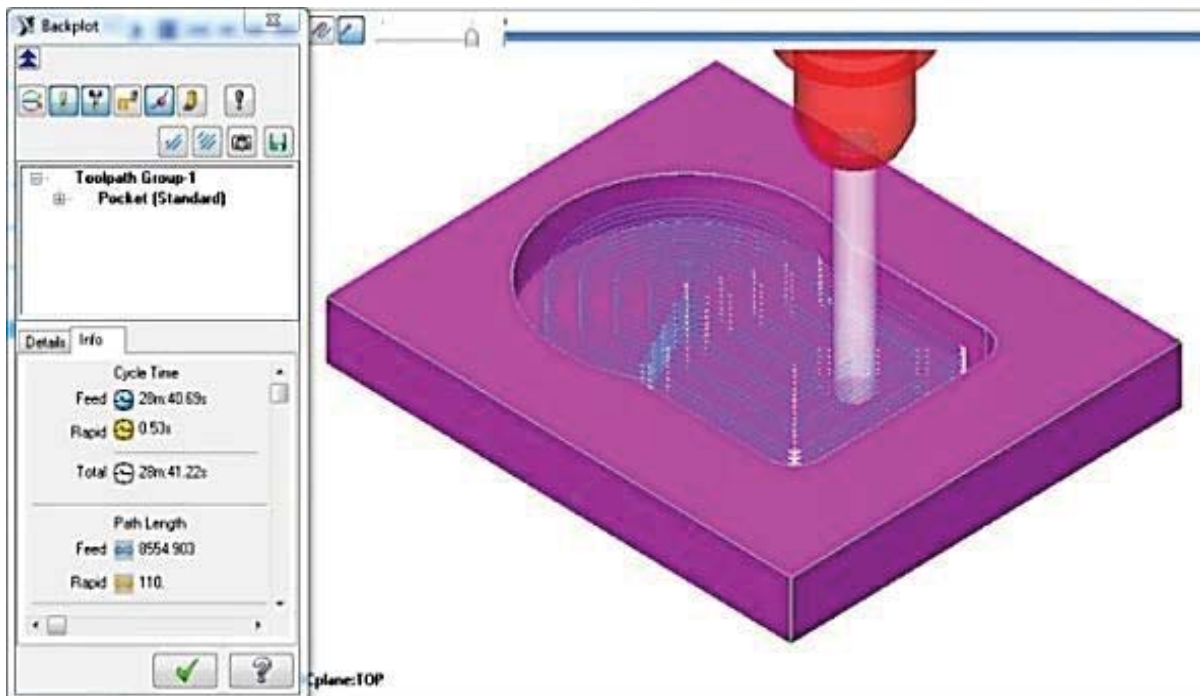

Fig. 8 Back plot of Warm cast model

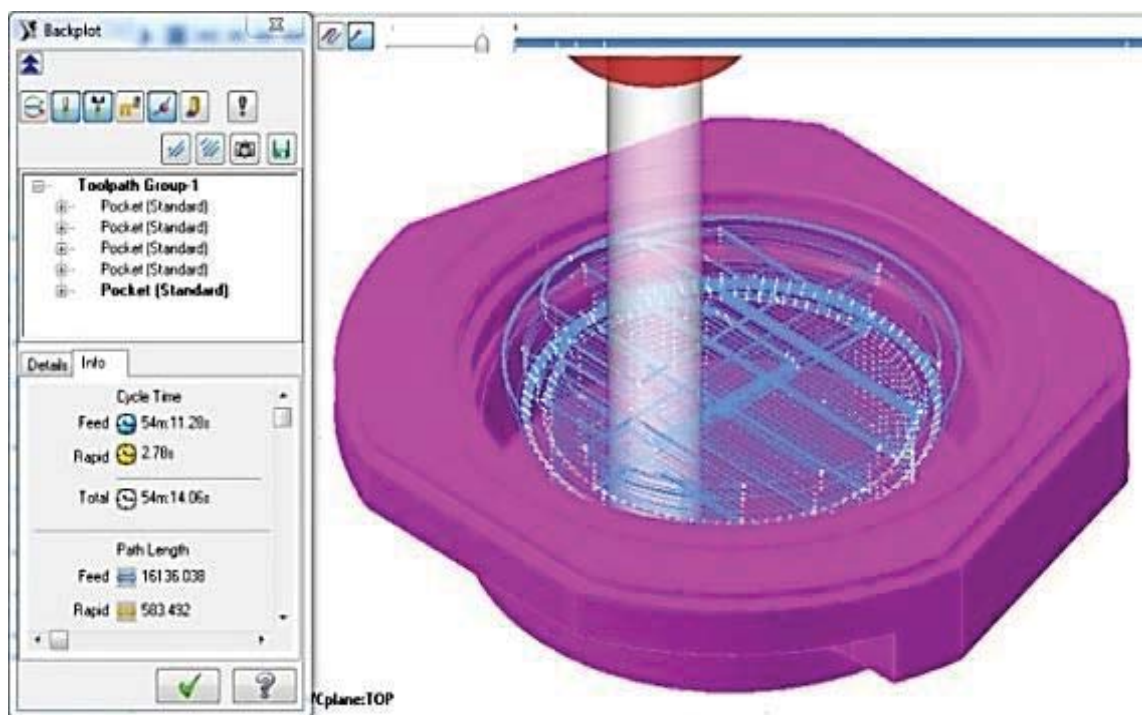

Fig. 9 Back plot of Clamping Piece



Fig. 10 Warm Cast after Machining



Fig. 11 Clamping Piece after Machining

VI. RESULT AND DISCUSSION

A. Simulation Result

1. Application of Different Toolpath

Simulation results of Warm cast are carried out in Tables II, III and IV respectively for 12 mm diameter tool, 6 mm diameter tool, and multi tool (12 mm and 6 mm). Simulation results present path length and time which are given by Back plot and material left or not are given by Verify. Comparing all results, parallel spiral clean corners gives optimize length and time of 8664.903 mm and 28m 41.22 s respectively.

Simulation results of clamping piece are carried out as in Tables V and VI respectively for 12 mm diameter tool and 6 mm diameter tool. Comparing all results, **Zigzag** gives optimal length and time of 16890.605 mm and 54 m 48.39 s respectively.

2. Combination of Toolpath

Combination of toolpath is another technique for the optimization. Here Parallel Spiral toolpath is used as pair with other toolpath. Table VII shows simulation results for combination of toolpath. Combination of parallel spiral and parallel spiral clean corners gives optimize length and time of 9859.376 mm and 32 m 5.40 s respectively.

3. Multi Tool Selection

Multi Tool Selection is another technique for the optimization. here Multi tool is used for reduction of toolpath. Tables VIII and IX show Simulation results for multi tool selection. Multi tool gives the expected results of length and time.

4. Reduce Air Time

Retrack is used for second pass of toolpath after completion of one pass during machining. Its benefit is that there is no damage regarding to clamp. Minor retrack gives reduction in length and time which is shown in Tables X and XI. Choose the option – ‘keep tool down’ on selection of parameters in MasterCAM®. There is no reduction in time regarding to retrack.

VII. EXPERIMENTAL RESULTS

From the optimized result, the programs of parallel spiral clean corners for warm cast and Zig-zag for Clamping piece are generated by post processing in MasterCAM®. The controller of VMC PX10 gives the machine simulation and actual machining time. These programs are imported in 3-axis VMC to carry out Experiment result. Tables XII and XIII give comparison of simulation and experimentation results.

TABLE II
SIMULATION RESULT OF WARMCAST FOR 12 MM DIAMETER

Sr. No.	Toolpath Method	Path Length (mm)		Time (HH:MM:SS)			%	Material Left
		Feed	Rapid	Feed	Rapid	Total		
1	Zigzag	9260.444	110	32m 2.27s	0.53s	31m 2.80s	62.68	
2	Constant Overlap Spiral	9160.047	110	30m 42.12s	0.53s	30m 42.65s	62.00	
3	Parallel Spiral	8257.732	110	27m 41.06s	0.53s	27m 41.68s	55.91	√
4	Parallel Spiral Clean Corners	8554.903	110	28m 40.69s	0.53s	28m 41.22s	57.92	
5	Morph Spiral	14785.829	110	49m 31.04s	0.53s	49m 31.57s	100	
6	One Way	10177.647	10517.426	37m 19.18s	50.48s	38m 9.66s	77.05	
7	True Spiral	11294.85	110	39m 56.93s	0.53s	39m 57.46s	80.67	

TABLE III
SIMULATION RESULT OF WARMCAST FOR 6 MM DIAMETER

Sr. No.	Toolpath Method	Path Length (mm)		Time (HH:MM:SS)			%	Material Left
		Feed	Rapid	Feed	Rapid	Total		
1	Zigzag	16031.249	110	1h 16m 47.96s	0.53s	1h 16m 48.49s	56.77	√
2	Constant Overlap Spiral	17056.031	110	1h 21m 42.16s	0.53s	1h 21m 42.68s	60.39	
3	Parallel Spiral	16134.637	110	1h 17m 17.64s	0.53s	1h 17m 18.17s	57.13	√
4	Parallel Spiral Clean Corners	16516.828	110	1h 19m 7.36s	0.53s	1h 19m 7.89s	58.49	
5	Morph Spiral	28253.492	110	2h 15m 16.74s	0.53s	2h 15m 17.27s	100	
6	One Way	18333.197	110	1h 36m 59.02s	1m 42.90s	1h 38m 41.92s	72.95	√
7	True Spiral	22799.734	110	1h 49m 11.07s	0.53s	1h 49m 11.59s	80.71	

TABLE IV
SIMULATION RESULTS OF WARMCAST FOR 12 MM AND 6MM DIAMETER

Sr. No.	Toolpath Method	Path Length (mm)		Time (HH:MM:SS)			%	Material Left
		Feed	Rapid	Feed	Rapid	Total		
1	Zigzag	9595.117	220	32m 50.23s	1.06s	32m 51.29s	60.89	√
2	Constant Overlap Spiral	9827.781	220	33m 36.92s	1.06s	33m 37.98s	60.33	
3	Parallel Spiral	8948.592	220	30m 40.49s	1.06s	30m 41.55s	56.88	√
4	Parallel Spiral Clean Corners	9226.523	220	31m 36.41s	1.06s	31m 37.32s	58.60	√
5	Morph Spiral	15904.886	220	53m 56.41s	1.06s	53m 57.46s	100	
6	One Way	10508.886	10922.89	39m 6.45s	52.43s	39m 58.88s	74.09	√
7	True Spiral	13211.486	220	44m 55.92s	1.06s	44m 56.98s	83.30	

TABLE V
SIMULATION RESULTS OF CLAMPING PIECE FOR 12 MM DIAMETERS

Sr. No.	Toolpath Method	Path Length (mm)		Time (HH:MM:SS)			%
		Feed	Rapid	Feed	Rapid	Total	
1	Zigzag	16307.113	583.492	54m 45.61s	7.78s	54m 48.39	69.77
2	Constant Overlap Spiral	17496.704	553.999	58m 44.22s	2.65s	58m 46.87s	74.83
3	Parallel Spiral	16788.9	569.393	56m 22.29s	2.72s	56m 25s	71.82
4	Parallel Spiral Clean Corners	16788.9	569.393	56m 22.29s	2.72s	56m 25s	71.82
5	Morph Spiral	19122.83	561.912	1h 4m 10.63s	2.69s	1h 4m 13.32s	81.76
6	One Way	20618.284	12635.284	1h 17m 32.06s	1m 0.63s	1h 18m 32.70s	100
7	True Spiral	18369.567	568.129	1h 1m 39.48s	2.72s	1h 1m 42.19s	78.55

TABLE VI
SIMULATION RESULTS OF CLAMPING PIECE FOR 6 MM DIAMETERS

Sr. No.	Toolpath Method	Path Length (mm)		Time (HH:MM:SS)			%
		Feed	Rapid	Feed	Rapid	Total	
1	Zigzag	33937.714	659.83	2h 42m 41.82s	2.67s	2h 42m 44.59s	65.54
2	Constant Overlap Spiral	35355.446	550.562	2h 49m 28.83s	2.64s	2h 49m 31.47s	68.27
3	Parallel Spiral	33996.6	550.002	2h 42m 58.73s	2.63s	2h 43m 1.36s	65.65
4	Parallel Spiral Clean Corners	33996.6	550.002	2h 42m 58.73s	2.63s	2h 43m 1.36s	65.65
5	Morph Spiral	36933.39	548.002	2h 57m 1.82s	2.62s	2h 57m 4.44s	71.31
6	One Way	43678.483	37325.006	4h 5m 18.83s	2m 59.10s	4h 8m 17.93s	100
7	True Spiral	36610.741	553.236	2h 55m 29.20s	2.65s	2h 55m 31.85s	70.69

TABLE VII
SIMULATION RESULTS FOR COMBINATION TOOLPATH OF WARMCAST

Sr. No.	Toolpath Method	Path Length (mm)		Time (HH:MM:SS)			%
		Feed	Rapid	Feed	Rapid	Total	
1	Zigzag	9772.259	289.707	32m 40.99s	1.30s	32m 42.28	77.37
2	Constant Overlap Spiral	10090.686	272.941	32m 44.89s	1.30s	33m 46.19s	79.89
3	Parallel Spiral Clean Corners	10389.807	270.927	32m 4.10s	1.29s	32m 5.40s	75.92
4	Morph Spiral	12444.145	267.044	34m 44.91s	1.27s	34m 46.19s	82.26
5	One Way	10112.273	8105.122	41m 37.15s	38.81s	42m 15.96s	100
6	True Spiral	9772.259	270.315	33m 49.22s	1.29s	33m 50.51s	80.06

TABLE VIII
SIMULATION RESULTS OF CONSTANT OVERLAP SPIRAL FOR MULTI TOOL SELECTION

Sr. No.	Tool Selection	Path Length (mm)		Time (HH:MM:SS)		%
		Feed	Rapid	Feed	Rapid	
1	8 mm Solid Carbide	12979.445	110	1h 4m 53.83s	100	
2	12 mm and 8mm	9705.492	220	33m 9.41s	51.10	

TABLE X
CONSTANT OVERLAP SPIRAL TOOLPATH FOR REDUCE AIR TIME

Sr. No.	Retract	Path Length (mm)		Time (HH:MM:SS)		%
		Feed	Rapid	Feed	Rapid	
1	10	3635.553	224.166	12m 10.61s	98.78	
2	25	3635.553	284.166	12m 10.90s	98.91	
3	0 (Keep Tool Down)	3679.719	110	12m 18.93s	100	

TABLE IX
SIMULATION RESULTS OF MORPH SPIRAL TOOLPATH FOR MULTI TOOL SELECTION

Sr. No.	Tool Selection	Path Length (mm)		Time (HH:MM:SS)		%
		Feed	Rapid	Feed	Rapid	
1	8 mm Solid Carbide	21782.588	110	1h 48m 55.30s	100	
2	12 mm and 8mm	15886.278	220	53m 47.66s	49.38	

TABLE XI
SIMULATION RESULTS OF ZIGZAG TOOLPATH FOR REDUCE AIR TIME

Sr. No.	Retract	Path Length (mm)		Time (HH:MM:SS)		%
		Feed	Rapid	Feed	Rapid	
1	10	3604.994	300.932	12m 4.85s	96.79	
2	25	3604.994	360.932	12m 5.14s	96.92	
3	0 (Keep Tool Down)	3725.926	110	12m 28.21s	100	

TABLE XII
EXPERIMENTAL RESULTS OF WARM CAST FOR PARALLEL SPIRAL CLEAN CORNERS TOOLPATH

Sr. No.	Method	Software Simulation Time	Software Simulation Time	Actual Machining Time
1	Parallel Spiral Clean Corners Toolpath	28m 41.22s	30m 28s	30m 25s

TABLE XIII
EXPERIMENTAL RESULTS OF CLAMPING PIECE FOR ZIGZAG TOOLPATH

Sr.No.	Method	Software Simulation Time	Software Simulation Time	Actual Machining Time
1	Zigzag Toolpath	54m 48.39s	55m	54m 58s

VIII. CONCLUSION

In the present study, the effect of toolpath optimization techniques for pocketing operation on Aluminum component using MasterCAM® X3 has been investigated in VMC PX10. The important conclusions from the present research work are summarized as per:

- It has been observed that the cycle time is improved by reducing machining time by selection of proper tool path strategy and modifying some of the design parameters of cyclic time such as spindle speed, feed rate, plunge rate, depth of cut and stepover.

- There are multiple tools used for optimization of toolpath. The larger diameter tool is used to save time for rough machining, after that the smaller diameter tool is used for finishing.
- The tool traverses rapidly when there is no feedrate needed at movement in air. Lower Retract rate is used for reducing the air time in MasterCAM® X3.

The research work can be extended by the combination of toolpath generation for minimum machining time. It can be also possible the optimization of toolpath for machining a pocketing operation by modifying the NC part program.

ACKNOWLEDGMENT

This research work was supported by the MAN Turbo India Private Limited – Vadodara and Chandubhai S. Patel Institute of Technology Mechanical Engg. Dept. Charusat University, Changa, Gujarat, India.

REFERENCES

- [1] Krajnik P and Kopac J, 2004, "Modern machining of die and mold tools," *Journal of Materials Processing Technology*, 157–158, pp. 543–552.
- [2] Lamikiz A, López De Lacalle LN, Sánchez JA, Salgado MA, 2005, "Cutting force integration at the CAM stage in the high-speed milling of complex surfaces", *International Journal of Computer Integrated Manufacturing*, 18(7), pp. 586 – 600.
- [3] Hyun Chul Kim, 2007, "Tool path modification for optimized pocket milling," *International Journal of Production Research*, 45(24), pp. 5715–5729.
- [4] Zhao Zhenyu, Liu Bai, Zhang Meng, Zhou Houming, Yu Songsen, 2009, "Toolpath Optimization for high speed milling of pockets," *IEEE*.
- [5] Bouaziz Z and Zghal A, 2008, "Optimization and selection of cutters for 3D pocket Machining," *International Journal of Computer Integrated Manufacturing*, 21(1), pp. 73 – 88.
- [6] Veeramani D and Gau YS, 1997, "Selection of an optimal set of cutting-tools for a general triangular pocket," *International Journal of Production Research*, 35(9), pp. 2621-2637.
- [7] Soepardi A, Chaeron M, Aini F L, 2010, "Optimization Problems Related to Triangular Pocket Machining," *IEEE*.
- [8] Tawfik T EL-Midany, Ahmed Elkeran, Hamdy Tawfik, 2006, "Toolpath pattern comparison – contour parallel with direction parallel," *IEEE*.
- [9] Central Machine Tool Institute, Bangalore, 2008, "Machine Tool Design Handbook," Tata McGraw-Hill Publishing Company Limited, New Delhi, pp. 654-661.