

# Nine-Level Shunt Active Power Filter Associated with a Photovoltaic Array Coupled to the Electrical Distribution Network

Zahzouh Zoubir, Bouzaouit Azzeddine, Gahgah Mounir

**Abstract**—The use of more and more electronic power switches with a nonlinear behavior generates non-sinusoidal currents in distribution networks, which causes damage to domestic and industrial equipment. The multi-level shunt power active filter is subsequently shown to be an adequate solution to the problem raised. Nevertheless, the difficulty of adjusting the active filter DC supply voltage requires another technology to ensure it. In this article, a photovoltaic generator is associated with the DC bus power terminals of the active filter. The proposed system consists of a field of solar panels, three multi-level voltage inverters connected to the power grid and a non-linear load consisting of a six-diode rectifier bridge supplying a resistive-inductive load. Current control techniques of active and reactive power are used to compensate for both harmonic currents and reactive power as well as to inject active solar power into the distribution network. An algorithm of the search method of the maximum power point of type Perturb and observe is applied. Simulation results of the system proposed under the MATLAB/Simulink environment shows that the performance of control commands that reassure the solar power injection in the network, harmonic current compensation and power factor correction.

**Keywords**—MPPT, active power filter, PV array, perturb and observe algorithm, PWM-control.

## I. INTRODUCTION

THE solar energy captured using photovoltaic panels is a viable alternative energy source for power generation because it is an unlimited renewable source and with a much reduced level of risk. Its potential is very important in terms of the need for human activity; it is also very widely distributed throughout the world, which gives it an interest shared by all. With the reduction in the price of photovoltaic modules and the increase in the price of fossil fuels, the exploitation of this resource with PV generation systems becomes viable and profitable. The rapid growth in the use of non-linear loads in power systems tends to degrade the quality of electric power supplied to consumers. In order to overcome these problems of harmonic pollution, the active filtering of electricity proves to be an adequate and effective solution [1]. The inverters connected to the multifunctional network have attracted increasing attention for their advantages over ancillary

services to mitigate the harmonics on improving power quality in networks [2]. Several control strategies have been developed to control the DC-DC converter in order to extract the maximum amount of energy from the photovoltaic network [3]. Also, a new Maximum Power Point Tracking (MPPT) algorithm is proposed to efficiently improve the performance of the solar panels [4]. This work proposes the characteristics of an association between a photovoltaic generator (GPV), whose purpose is to inject active power on an electrical network, and a parallel active filter whose task is to eliminate the disturbances presented at the level of this network [5]. These disturbances are due to non-linear loads and are characterized by harmonic pollution, the presence of reactive energy or imbalances.

## II. CONFIGURATION DESCRIPTION

Fig. 1 illustrates a configuration composed of a solar PV generator connected to the DC bus of a three-phase voltage inverter, mounted in parallel to the three-phase network through an inductance by each phase. This electrical network supplies a non-linear receiver constituted by a rectifier with six diodes feeding an inductive resistive load. The analysis of power fluxes is thus examined in various regimes imposed by the fluctuation of the level of irradiation during the diurnal period and the alternation with the nocturnal part, where only the functions of the active filter are activated. It should be noted that with this principle of hardware investment is identical to a photovoltaic installation connected to the network, but with the addition of the functionalities of an active filter in order to improve the quality of energy on the network at the point of connection. It is therefore the control algorithm of the voltage inverter, which is adapted in order to simultaneously provide attenuation of the harmonic disturbances at the level of the electrical network, the compensation of the reactive power and the injection of the power supplied by the PV panels. Fig. 2 explains the proposed topology of three multilevel active filters connected to the three-phase electrical network associated with PV generator. Each one contains four capacities  $C_1$ ,  $C_2$ ,  $C_3$  and  $C_4$ , seven bipolar switches  $S1$ ,  $S2$ ,  $S3$ ,  $S4$ ,  $S5$ ,  $S6$  and  $S7$  (Fig. 2). Three switches are enveloped by four diodes which are used to direct the current to pass through  $S5$ ,  $S6$  and  $S7$ . They generate the voltage levels  $3V_{dc}/4$ ,  $2V_{dc}/4$ ,  $V_{dc}/4$ ,  $-V_{dc}/4$ ,  $-2V_{dc}/4$ ,  $3V_{dc}/4$  and ensure the bidirectional for the current and the voltage across the ground and points ( $O_1$ ,  $O_2$  and  $O_3$ ) of the DC bus. To generate the nine levels of the output voltage, we have chosen

Zahzouh Zoubir is with the Mechanical Engineering Department, University of 20 Aôut 1955-Skikda, Algeria (corresponding author, e-mail: zzahzouh@yahoo.fr).

Bouzaouit Azzeddine and Gahgah Mounir are with the Mechanical Engineering Department, University of 20 Aôut 1955-Skikda, Algeria (e-mail: bouzaouit21@gmail.com, gahgah.mounir@gmail.com).

to dispose four capacitors ( $C_1, C_2, C_3, C_4$ ), which ensure a continuous supply of the filter DC bus; each one has an

amplitude equal to  $V_{dc}/4$ .

Table I summarizes the states for seven switches.

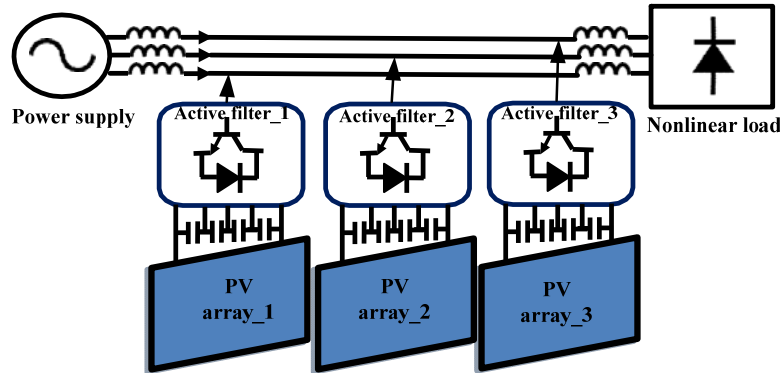

Fig. 1 Nine Level-APF linked associated with PV generator at the 3-phases electrical network

TABLE I  
SWITCHES STATES

S1	S2	S3	S4	S5	S6	S7	$V_{an}$
1	0	0	1	0	0	0	$V_{dc}$
1	0	0	0	0	0	1	$3V_{dc}/4$
1	0	0	0	0	1	0	$V_{dc}/2$
1	0	0	0	1	0	0	$V_{dc}/4$
1	0	1	0	0	0	0	0
0	1	0	0	0	0	1	$-V_{dc}/4$
0	1	0	0	0	1	0	$-V_{dc}/2$
0	1	0	0	1	0	0	$-3V_{dc}/4$
0	1	0	0	0	0	0	$-V_{dc}$

$$\begin{bmatrix} I_0 \\ I_\alpha \\ I_\beta \end{bmatrix} = \sqrt{\frac{2}{3}} \begin{bmatrix} \frac{1}{\sqrt{2}} & \frac{1}{\sqrt{2}} & \frac{1}{\sqrt{2}} \\ 1 & \frac{1}{2} & -\frac{1}{2} \\ 0 & \frac{\sqrt{3}}{2} & -\frac{\sqrt{3}}{2} \end{bmatrix} \begin{bmatrix} I_{ca} \\ I_{cb} \\ I_{cc} \end{bmatrix} \quad (2)$$

The currents  $I_\alpha, I_\beta$  contain the fundamental ( $\bar{I}_\alpha, \bar{I}_\beta$ ) and the harmonics ( $\tilde{I}_\alpha, \tilde{I}_\beta$ ):

$$\begin{cases} I_\alpha = \bar{I}_\alpha + \tilde{I}_\alpha \\ I_\beta = \bar{I}_\beta + \tilde{I}_\beta \end{cases} \quad (3)$$

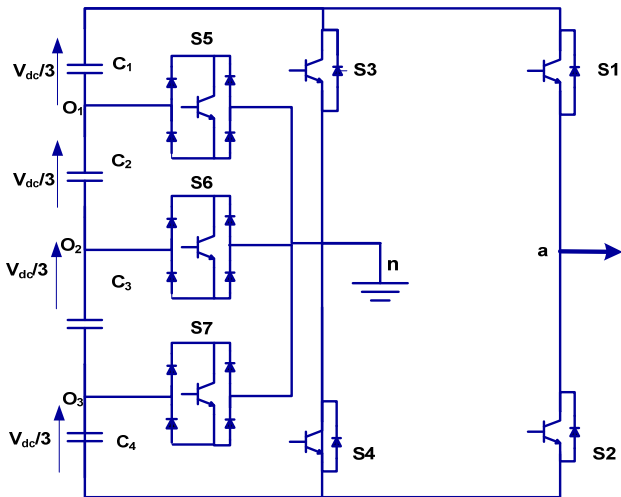

Fig. 2 Topology of the nine-level active filter

### III. IDENTIFICATION METHOD

The values of the voltages and currents in the space  $\alpha$ - $\beta$  can be written as follows:

$$\begin{bmatrix} v_0 \\ v_\alpha \\ v_\beta \end{bmatrix} = \sqrt{\frac{2}{3}} \begin{bmatrix} \frac{1}{\sqrt{2}} & \frac{1}{\sqrt{2}} & \frac{1}{\sqrt{2}} \\ 1 & \frac{1}{2} & -\frac{1}{2} \\ 0 & \frac{\sqrt{3}}{2} & -\frac{\sqrt{3}}{2} \end{bmatrix} \begin{bmatrix} v_{an} \\ v_{bn} \\ v_{cn} \end{bmatrix} \quad (1)$$

The Notch filter removes the fundamental component of harmonic currents (Figs. 3 (a) and (b)); also using the bandpass filter to obtain the fundamental reactive power  $\bar{q}$ (50Hz) (Fig. 3 (c)):

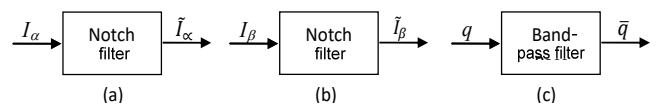

Fig. 3 Bandpass and Notch filters

The harmonics active and reactive powers are computed as:

$$\begin{bmatrix} \tilde{p} \\ \tilde{q} \end{bmatrix} = \begin{bmatrix} v_\alpha & v_\beta \\ -v_\beta & v_\alpha \end{bmatrix} \begin{bmatrix} \tilde{I}_\alpha \\ \tilde{I}_\beta \end{bmatrix} \quad (4)$$

The reference currents must include  $\tilde{p}, \tilde{q}$  and  $\bar{q}$  compensating in the same time the reactive power and harmonic currents generated by the nonlinear load as follows:

$$\begin{bmatrix} \tilde{I}_{\alpha-ref} \\ \tilde{I}_{\beta-ref} \end{bmatrix} = \frac{1}{v_\alpha^2 + v_\beta^2} \begin{bmatrix} v_\alpha & -v_\beta \\ v_\beta & v_\alpha \end{bmatrix} \begin{bmatrix} \tilde{p} \\ \tilde{q} \end{bmatrix} + \frac{1}{v_\alpha^2 + v_\beta^2} \begin{bmatrix} v_\alpha & -v_\beta \\ v_\beta & v_\alpha \end{bmatrix} \begin{bmatrix} 0 \\ \bar{q} \end{bmatrix} \quad (5)$$

The reference currents in the a-b-c space are expressed by:

$$\begin{bmatrix} I_{ref1} \\ I_{ref2} \\ I_{ref3} \end{bmatrix} = \sqrt{\frac{2}{3}} \begin{bmatrix} 1 & 0 \\ -\frac{1}{2} & \frac{\sqrt{3}}{2} \\ -\frac{1}{2} & -\frac{\sqrt{3}}{2} \end{bmatrix} \begin{bmatrix} \tilde{I}_{\alpha-ref} \\ \tilde{I}_{\beta-ref} \end{bmatrix} \quad (6)$$

#### IV. ACTIVE FILTER COMMAND STRATEGY

The pulse width modulation technique is mainly based on the comparison between the reference current signal ( $I_{ref}$ ) and the eight identical triangular carriers ( $U_{p1}, U_{p2}, U_{p3}, U_{p4}, U_{p5}, U_{p6}, U_{p7}$  and  $U_{p8}$ ). It sends seven logic signals at the same time, 0 or 1 for each to the switches (S1, S2, S3, S4, S5, S6, and S7).

The four carriers  $U_{p1}, U_{p2}, U_{p3}$  and  $U_{p4}$  are used to generate the levels  $V_{dc}, 3V_{dc}/4, V_{dc}/2$  and  $V_{dc}/4$ , respectively. By symmetry, the negative levels are produced by  $U_{p5}, U_{p6}, U_{p7}$  and  $U_{p8}$ , respectively. The level  $V_{dc}=0$  is obtained when the reference signal is situated between the carriers  $U_{p4}$  and  $U_{p5}$ . Nine levels of the proposed Active Filter output voltage ( $V_{an}$ ) respect nine conditions as follows:

1. If  $I_{ref} \geq U_{p1}$ ,  $v_{an} = v_{dc}$ .
2. If  $U_{p1} > I_{ref} \geq U_{p2}$ ,  $v_{an} = (3/4)v_{dc}$ .
3. If  $U_{p2} > I_{ref} \geq U_{p3}$ ,  $v_{an} = (1/2)v_{dc}$ .
4. If  $U_{p3} > I_{ref} \geq U_{p4}$ ,  $v_{an} = (1/4)v_{dc}$ .
5. If  $U_{p4} > I_{ref} \geq U_{p5}$ ,  $v_{an} = 0$ .
6. If  $U_{p5} > I_{ref} \geq U_{p6}$ ,  $v_{an} = -(1/4)v_{dc}$ .
7. If  $U_{p6} > I_{ref} \geq U_{p7}$ ,  $v_{an} = -(1/2)v_{dc}$ .
8. If  $U_{p7} > I_{ref} \geq U_{p8}$ ,  $v_{an} = -(3/4)v_{dc}$ .
9. If  $U_{p8} > I_{ref}$ ,  $v_{an} = -v_{dc}$ .

#### V. CAPACITORS SIZING OF THE DC BUS

In order to calculate the capacitors values that supply the active filter, the transient variations in the instantaneous power are absorbed by the load engender fluctuations in voltage  $V_{dc}$  of the capacitors.

The amplitude of these fluctuations can be determined by a meticulous choice of the equivalent capacity value  $C$  which is expressed by:  $C = (12 \cdot I_{FA}) / (\Delta V_{dc} \cdot \pi \cdot \omega_s) \cdot I_{FA}$  is the maximum amplitude of the injected current.  $\Delta V_{dc}$  is the fluctuation equal to 5% of  $V_{dc}$ .  $\omega_s = 2\pi \cdot f_s$ , where  $f_s$  is the switching frequency of the carriers. In this case,  $I_{FA} = 40A$  with  $I_{FA}$  (in the 2<sup>nd</sup> time presented in the results),  $V_{dc} = 1000V$ ,  $\Delta V_{dc} = 5\%V_{dc}$ ,  $f_s = 10$  kHz,  $C$  will equal to  $36.47\mu F$ ; Then:  $C_1 = C_2 = C_3 = C_4 = 4C = 146\mu F$ , because  $C_1, C_2, C_3$  and  $C_4$  are connected in series.

#### VI. REGULATION

The four capacitors  $C_1, C_2, C_3$  and  $C_4$  must be supplied with voltages of constant and equal values. This is achieved by the solar PV generator controlled by the MPPT technique applied with the algorithm perturb and observe.

In order to inject a current equal to the harmonic current (Fig. 4), it is carried out by absorbing or injecting active power on the network, this is most often done by an integral proportional regulator PI (from the difference between the voltage measured  $V_{dc} = V_{dc1} + V_{dc2} + V_{dc3} + V_{dc4}$  and the reference  $V_{dc-ref}$

#### VII. SIMULATION PARAMETERS

The simulation represents an association of a photovoltaic generator associated with the DC bus power terminals of the active filter. The proposed system consists of a field of solar panels, three multi-level voltage inverters connected to the power grid and a non-linear load consisting of a six-diode rectifier bridge supplying a resistive-inductive load. The study is done only in the phase  $a$ , knowing that the two other phases ( $b$  and  $c$ ) are delayed, respectively, by  $120^\circ$  and  $240^\circ$  relatively to phase  $a$ .

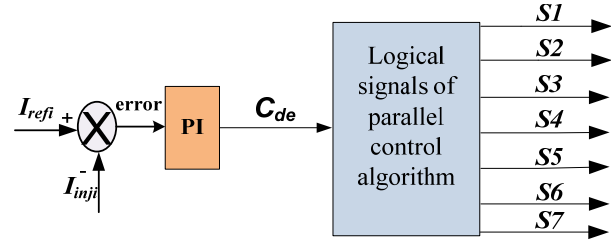

Fig. 4 Control block by the PI controller

TABLE II  
 SIMULATION PARAMETERS

Symbol	System Parameters	Values
$V_s$	Source voltage,	220 V
$L_s$	inductance line,	3.10-4 H
$F$	frequency	50Hz
$R$	Load. (rectifier with six diodes +resistance +inductance)	1st & 2nd 4Ω
$L$		time 0.001H
$R$		10Ω
$L$		3rd time 0.001H
$C_i$	Nine-level active filter capacitors voltage	145,6.10-6F
$i=1,2,3,4$	Inductance and resistance at output of the active filter	1,2.10-3H
$L_f$		25Ω
$R_f$	Irradiation	800 W/m2,
	Ambient temperature	20°C

#### VIII. RESULTS AND DISCUSSION

The supply current obtained before filtering is completely distorted and its current Harmonic Distortion (THD) is 25.35%. This value is higher than the international norm (THD<5%), as represented in Fig. 5.

After filter connection, in the 1<sup>st</sup> time, the filter is in the stop state from 0.00 s to 0.06 s. In the 2<sup>nd</sup> time, opening from 0.06s to 0.12s the proposed system begins to filter with the nonlinear load of  $R = 4\Omega$  and  $L = 0.001H$ . Then, an increase of the resistance value  $R = 10\Omega$  in the 3<sup>rd</sup> time of 0.12s to 0.2s. The high frequency of the carriers allowed the harmonic currents to be injected through the filter into the electrical network, as shown in Fig. 6. The supply current have a sinusoidal waveform with its THD equal to 3.32% in the 2<sup>nd</sup> time and to 1.96% at the 3<sup>rd</sup> time, as shown in Fig. 7. The proposed system is improved with a power factor closer to unity (Fig. 8).

Fig. 9 illustrates the feed currents that have sinusoidal waveforms with balanced phases  $a, b$ , and  $c$ . Similarly, the waveforms have the same amplitudes with the same frequencies. Fig. 10 illustrates the injection of the voltage by the active filter associated with the solar panel PV, whose

waveform is sinusoidal and amplitude of value that is almost constant whatever of the load variation.

Fig. 11 shows clearly the good Injection of active power profile without (1<sup>st</sup> time) and with the system installed (in 2<sup>nd</sup> and 3<sup>rd</sup> time); the reactive power approach to values zero.

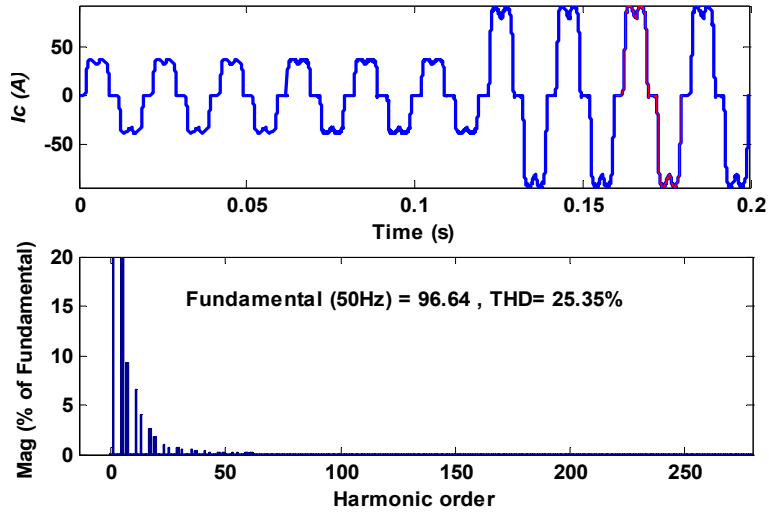

Fig. 5 Supply current and voltage waveforms and its harmonic currents spectrum before filtering

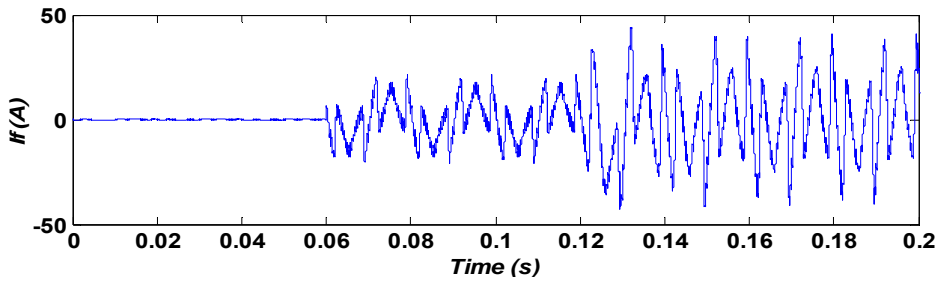

Fig. 6 Injected current

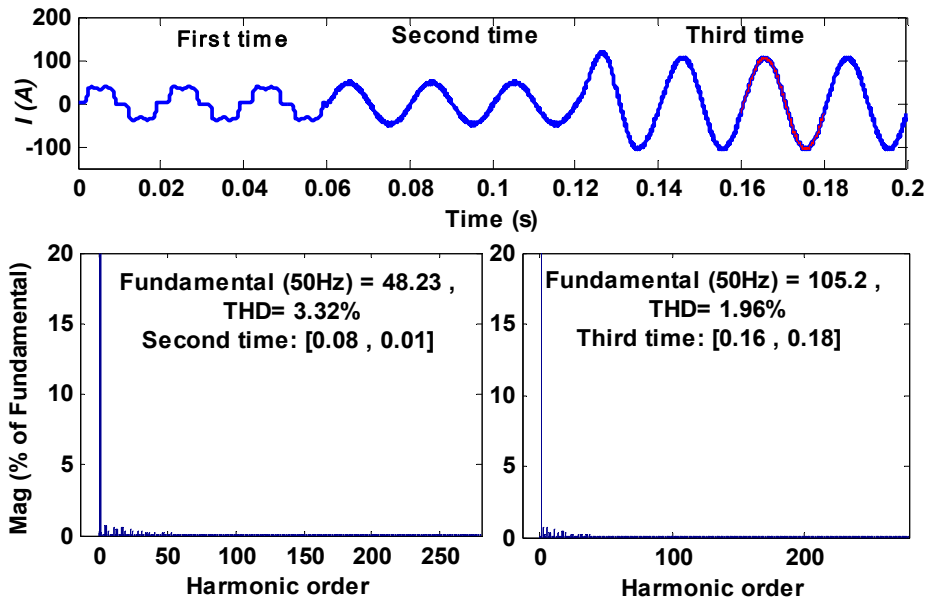

Fig. 7 Source current and its spectrums in 2<sup>nd</sup> and 3<sup>rd</sup> time, after filtering

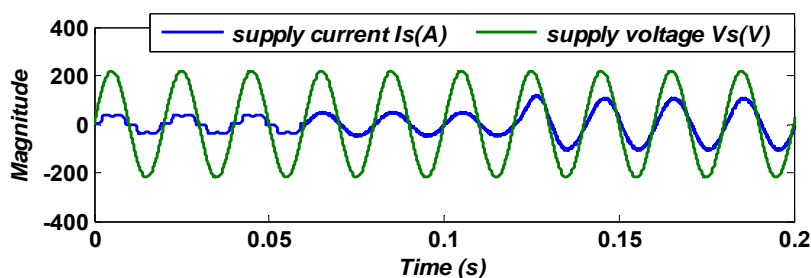

Fig. 8 Power Factor

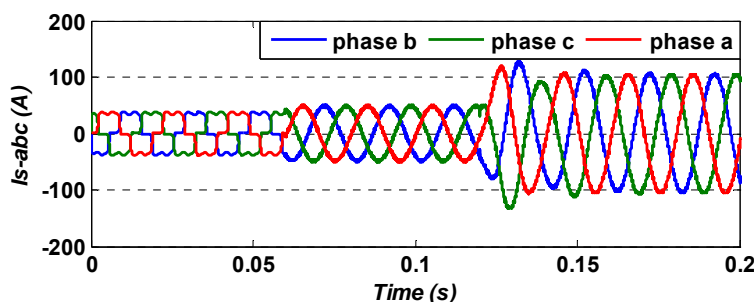

Fig. 9 Three-phase supply currents waveforms after filtering

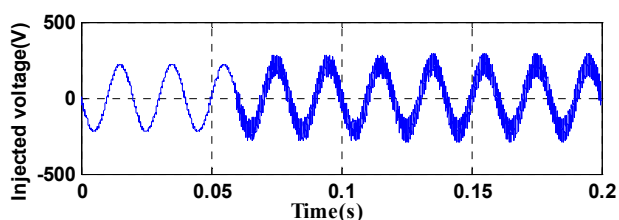

Fig. 10 Injected voltage waveform with and without the active filter

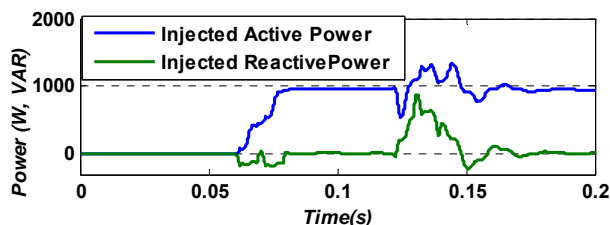

Fig. 11 Injected active & reactive power profiles with and without the active filter

### IX. CONCLUSION

The results confirm the effectiveness of the proposed system and ensure the different functionalities assigned to the active power filter, namely the compensation of the pollution of the harmonic currents, the reactive power and the transfer of the energy flow from the solar PV to the electrical network.

A proposed topology of a shunt active filter, based on a nine-level inverter is proposed in this study. This filter is controlled by a parallel algorithm through the developed PQ theory. The system model has been inserted in MATLAB/Simulink. Identification of harmonic currents has been obtained by the developed PQ theory. The control strategy PDPWM is included in the parallel algorithm that works with

eight triangular carriers of switching frequency equal to 15 kHz.

After connection of the filter, a significant reduction is obtained from the total harmonic distortion THD = 3.32% in 2<sup>nd</sup> time and THD = 1.96% in 3<sup>rd</sup> time in accordance with IEEE standards [6]. Finally, the proposed system gives a good compensation for both harmonic currents and reactive power as well as to inject active solar power into the distribution network with a power factor closer to unity.

### REFERENCES

- [1] Z. Zahzouh, L. Khochmane, A. Haddouche, "A New Multilevel Active Power Filter Using Switches Meticulously Controlled", *Journal of Power Electronics and Drive System*, Vol. 6, No. 1, 2015, pp. 168-177.
- [2] Zheng Zeng, HuanYang, Rongxiang Zhao, Chong Chen, "Topologies and control strategies of multi-functional gridconnected inverters for power quality enhancement: A comprehensive review", *Renewable and Sustainable Energy Reviews*, no. 24, pp. 223-270, 2013.
- [3] R. Noroozian, G. B. Gharehpetian, "An investigation on combined operation of active power filter with photovoltaic arrays", *Electrical Power and Energy Systems*, no. 46, pp. 392-399, 2013.
- [4] Ali Reza Reisi, Mohammad H. Moradi, Hemen Showkati, "Combined photovoltaic and unified power quality controller to improve power quality", *Solar Energy*, no. 88, pp. 154-162, 2013.
- [5] F. S. Kang, "Modified Multilevel Inverter Employing Half-and Full-bridge Cells With Cascade Transformer and its Extension to Photovoltaic Power Generation", *Electric Power Systems Research*, Vol. 80, No. 12, 2010, pp. 1437-1445.
- [6] C. K. Duffey, R. P. Stratford, "Update of Harmonic Standard IEEE-519: Recommended Practices and Requirements for Harmonic Control in Electric Power Supply System", *IEEE Transactions on Industry Applications*, Vol. 25, No. 6, 1989, pp. 1025-1034.