

# Simulation and Analytical Investigation of Different Combination of Single Phase Power Transformers

M. Salih Taci, N. Tayebi, I. Bozkır

**Abstract**—In this paper, the equivalent circuit of the ideal single-phase power transformer with its appropriate voltage current measurement was presented. The calculated values of the voltages and currents of the different connections single phase normal transformer and the results of the simulation process are compared. As it can be seen, the calculated results are the same as the simulated results. This paper includes eight possible different transformer connections. Depending on the desired voltage level, step-down and step-up application transformer is considered. Modelling and analysis of a system consisting of an equivalent source, transformer (primary and secondary), and loads are performed to investigate the combinations. The obtained values are simulated in PSpice environment and then how the currents, voltages and phase angle are distributed between them is explained based on calculation.

**Keywords**—Transformer, simulation, equivalent model, parallel series combinations.

## I. INTRODUCTION

**T**RANSFORMER is a static device which transfers energy from one circuit to another without change in frequency.

An ideal diagram of a step-up and step-down transformer is shown in Figs. 1 and 2, respectively. For the modelling of transformer, it is important to note that the transformer is assumed to be ideal, which means [1]-[4]:

1. Winding impedances are negligible.
2. All the fluxes set up by primary link the secondary winding, i.e. all the fluxes are confined to the magnetic core.
3. The core losses (hysteresis and eddy current losses) are negligible.
4. The core has constant permeability, i.e. the magnetization curve for the core is linear.
5. Total apparent input power equals the total apparent output power.

In this paper, a good explanation of one-phase operation in a simple circuit in the primary and secondary terminals step-up and step-down three-phase transformers is presented. So, many programs in these days are available to simulate and check the circuits. In this paper, we have used PSpice environment due to its user-friendly simulation interface. Modelling in this paper is valid for steady state ideal transformer.

In a power system, at light loads, only one transformer

M. S. T. is with the Electrical Engineering Department, Yildiz Technical University, Esenler. İstanbul, Turkey (corresponding author, e-mail: taci@yildiz.edu.tr).

N. T. and I. B. are with the Electrical Engineering Department, Yildiz Technical University, Esenler. İstanbul, Turkey (e-mail: navid.tayebi.tr@ieec.org, isilbozkir@gmail.com).

would be employed, and as the load increased, additional transformers would be connected in parallel as required. Nowadays, operation of power transformers in parallel is common and it is usually because of one of the following reasons [5], [6]:

1. Increased load: If the power of a load needs to be increased, one of the economical and easy solutions is to add a second transformer in parallel operation.
2. Flexible operation: Transformers can operate in parallel in several ways ensuring reliability, safety, critical load selection, and ease of maintenance operation without outage of service.
3. High power: Sometimes, it is the only way to operate in high power applications due to size and weight restrictions.

On the other hand, paralleled operation of power transformers has some disadvantages: increasing short-circuit currents, circulating currents that cause in increasing of copper losses, overloading one of the paralleled transformers, and reducing the permissible load kVA. When paralleling two transformers, some conditions should be met, they are mentioned here for single-phase transformers operating in parallel that we use them for our analyzing and calculations and simulations [7].

Voltage ratings and ratio of transformation should be equal. Equivalent impedances are inversely proportional to their current rating. Ratios of equivalent resistance to equivalent reactance are equal.

For paralleling two transformers especially in transmission and distribution systems, there exist some methods in literatures. Depiction of the fundamental presumption of operation for the most operated different paralleling methods is as follows [8]. There are so many researches in the field of parallel operation of transformers. One of the most attractive fields is the investigation of circulating current [9], [10].

## II. METHOD AND MATERIAL

For correct wiring, polarity marks are shown on circuit schematics. The polarity mark is usually shown as a round dot or adjacent to terminals. An ideal transformer circuit as a controlled source is shown in Figs. 1 and 2.

Fig. 3 shows the measurement circuit for a one-phase transformer, which is loaded with a resistive load and supplied with a sinusoidal voltage, for measuring the current and voltage values on the primary and secondary sides of the transformer. We analyzed parallel-parallel connected step-down transformer with a gain 0.5. The turn ratio of the transformer is determined as 2:1. 220 V-110 V, 50 Hz

sinusoidal source is used as supply source. The primary windings of transformer are connected in parallel, and the secondary windings are connected in parallel.

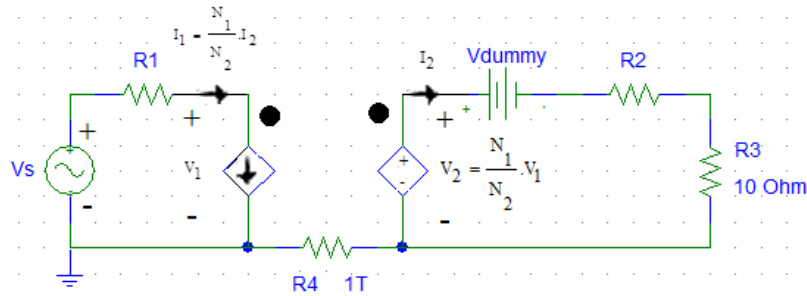

Fig. 1 Ideal single-phase step-down transformer equivalent circuit

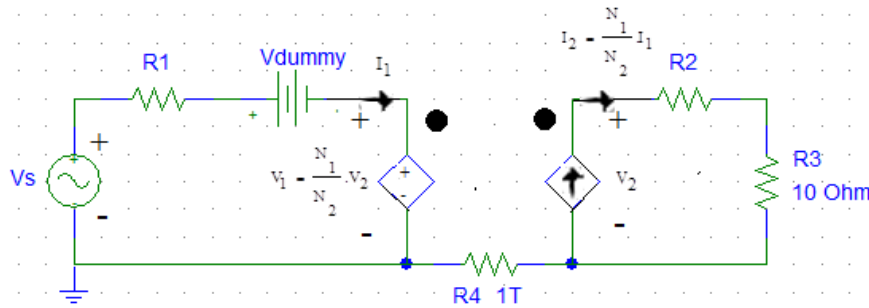

Fig. 2 Ideal single phase step-up transformer equivalent circuit

The results of the eight different transformer connections operating mode were obtained from analytical and simulations measurement. These eight possible different transformer connections have been simulated by PSpice program. The obtained calculated and simulated values were compared and validated. The transient analysis of simulation circuit is done through two periods. Time interval of this simulation is 0–40 ms. Fig. 3 (c) represents the resulted voltage and current of parallel-parallel connected step-down transformer (gain 0.5) of the simulation process. In this circuit, the connection of primary winding of the transformer is changing from parallel connection to serial connection at 60 ms. Secondary winding of the transformer serial connection is changing to parallel at 40 ms. Then, secondary winding of the transformer parallel connection is changing to serial at 80 ms.

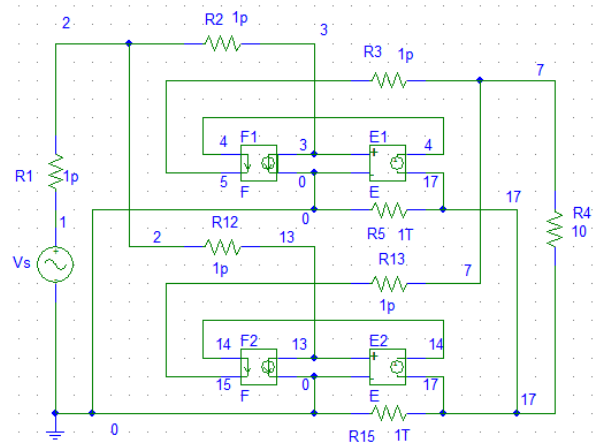

Fig. 3 (b) Schematic of the parallel-parallel step-down transformer

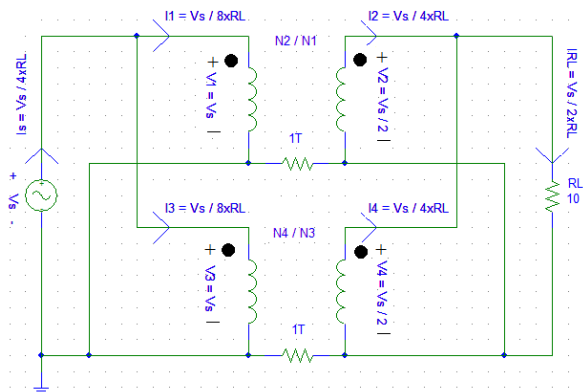

Fig. 3 (a) Equivalent circuit of the parallel-parallel step-down transformer

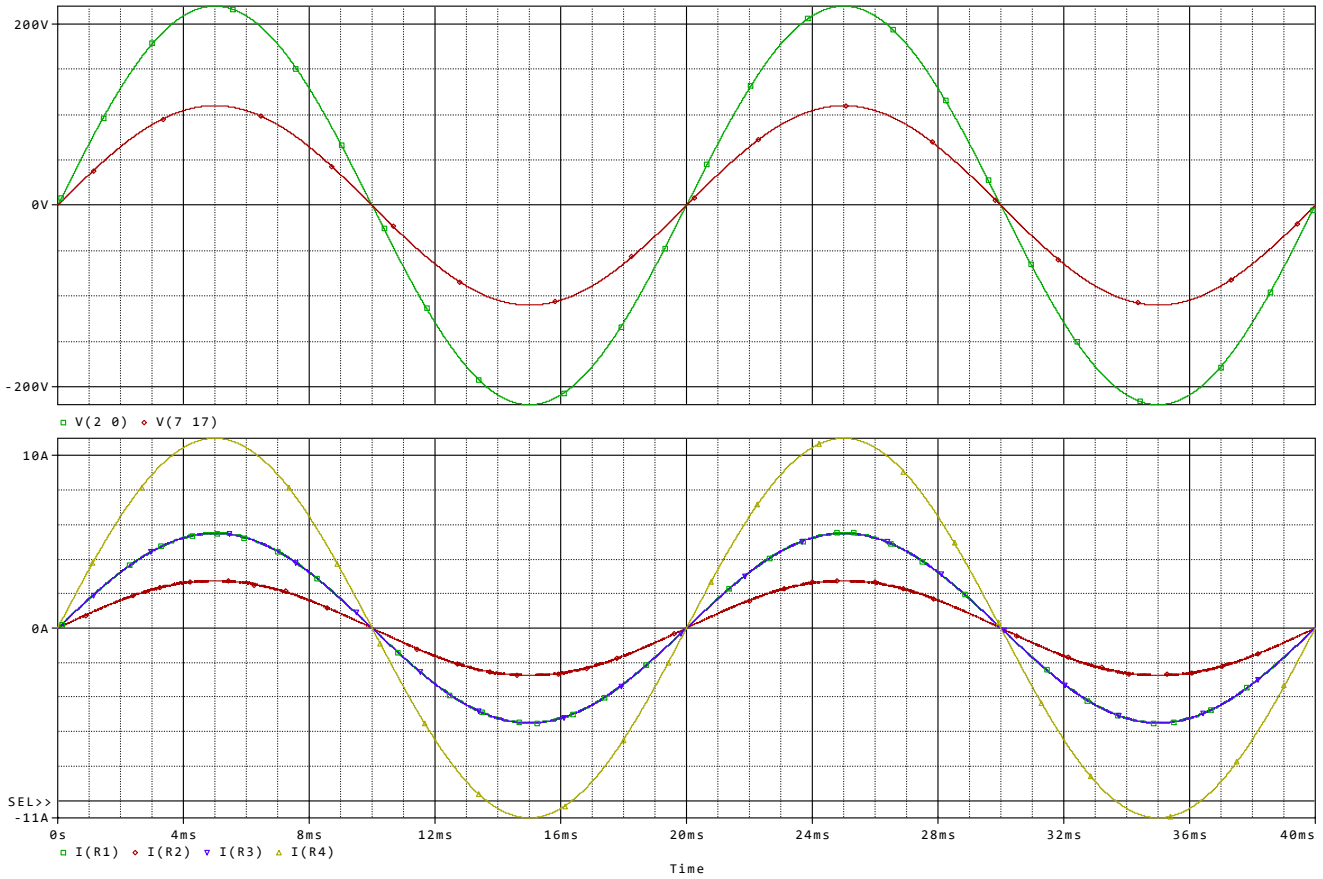

Fig. 3 (c) PSpice plot of voltages and currents of parallel-parallel step-down transformer (gain 0.5)

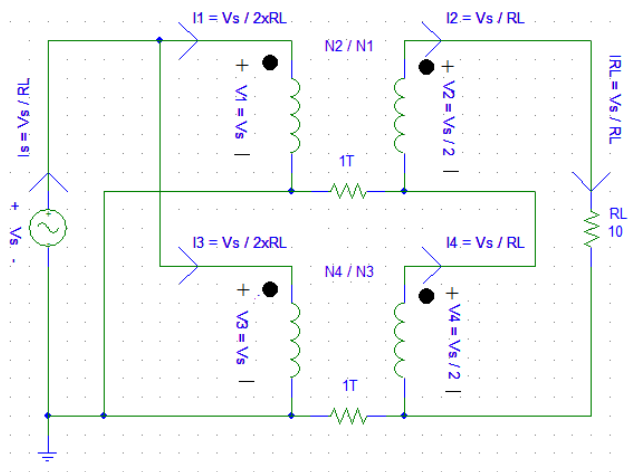

Fig. 4 (a) Equivalent circuit of the parallel-series step-down transformer

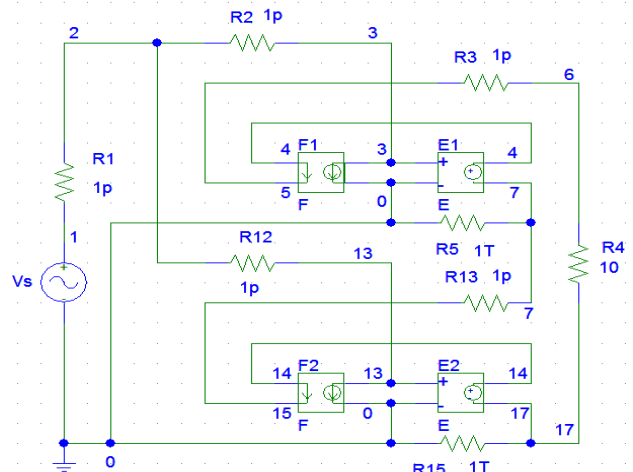

Fig. 4 (b) Schematic of the parallel-series step-down transformer

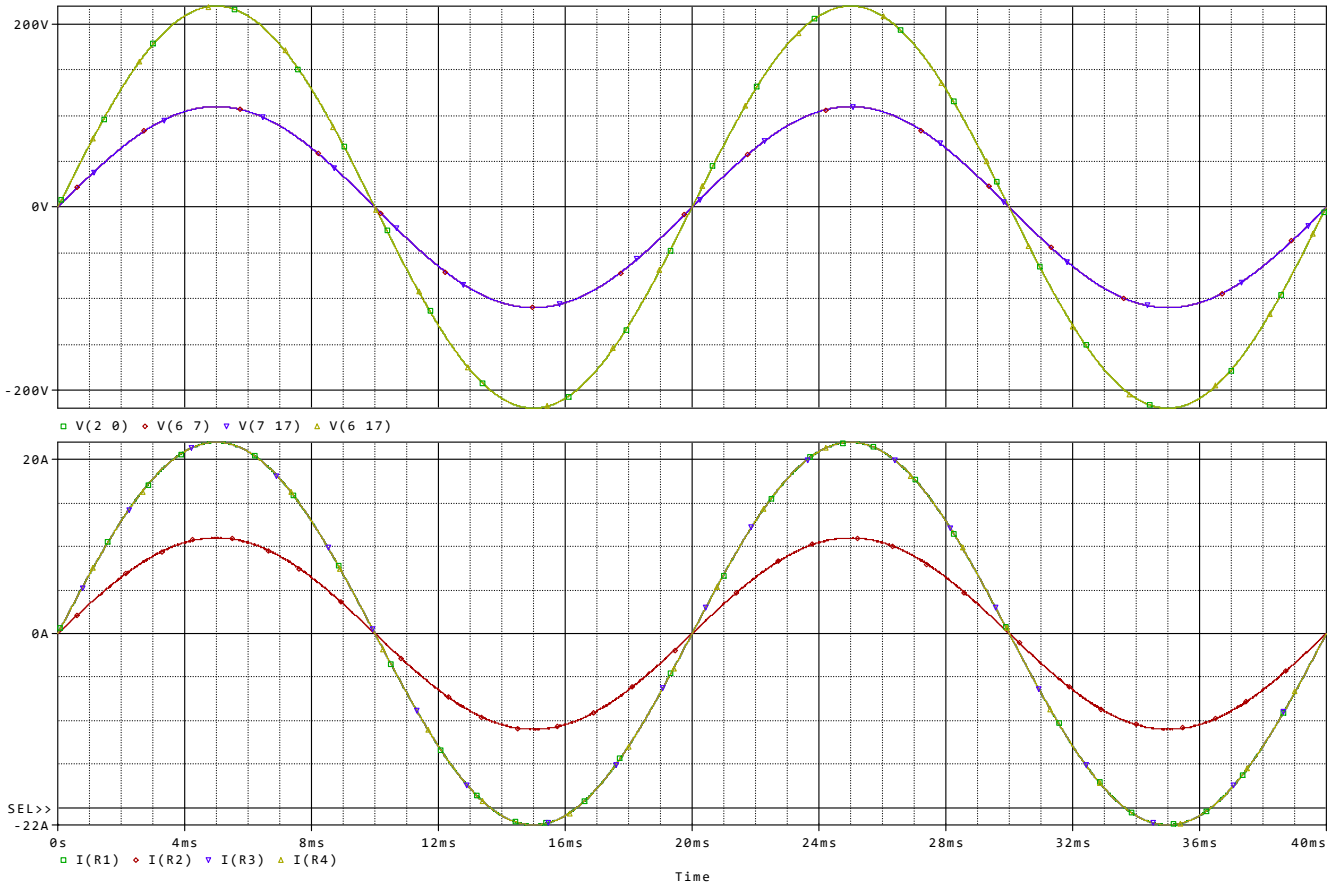

Fig. 4 (c) PSpice plot of voltages and currents of parallel-parallel step-down Transformer (gain 0.5)

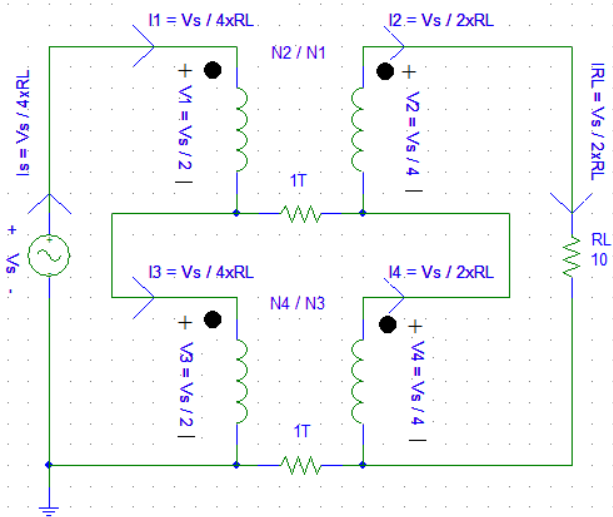

Fig. 5 (a) Equivalent circuit of the series-series step-down transformer

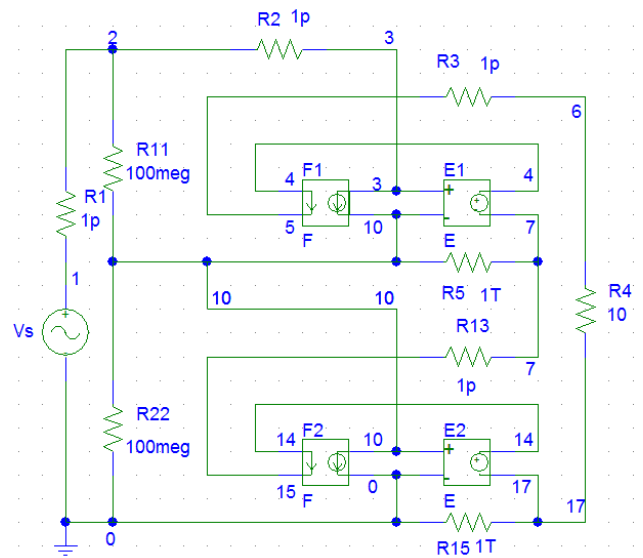

Fig. 5 (b) Schematic of the series-series step-down transformer

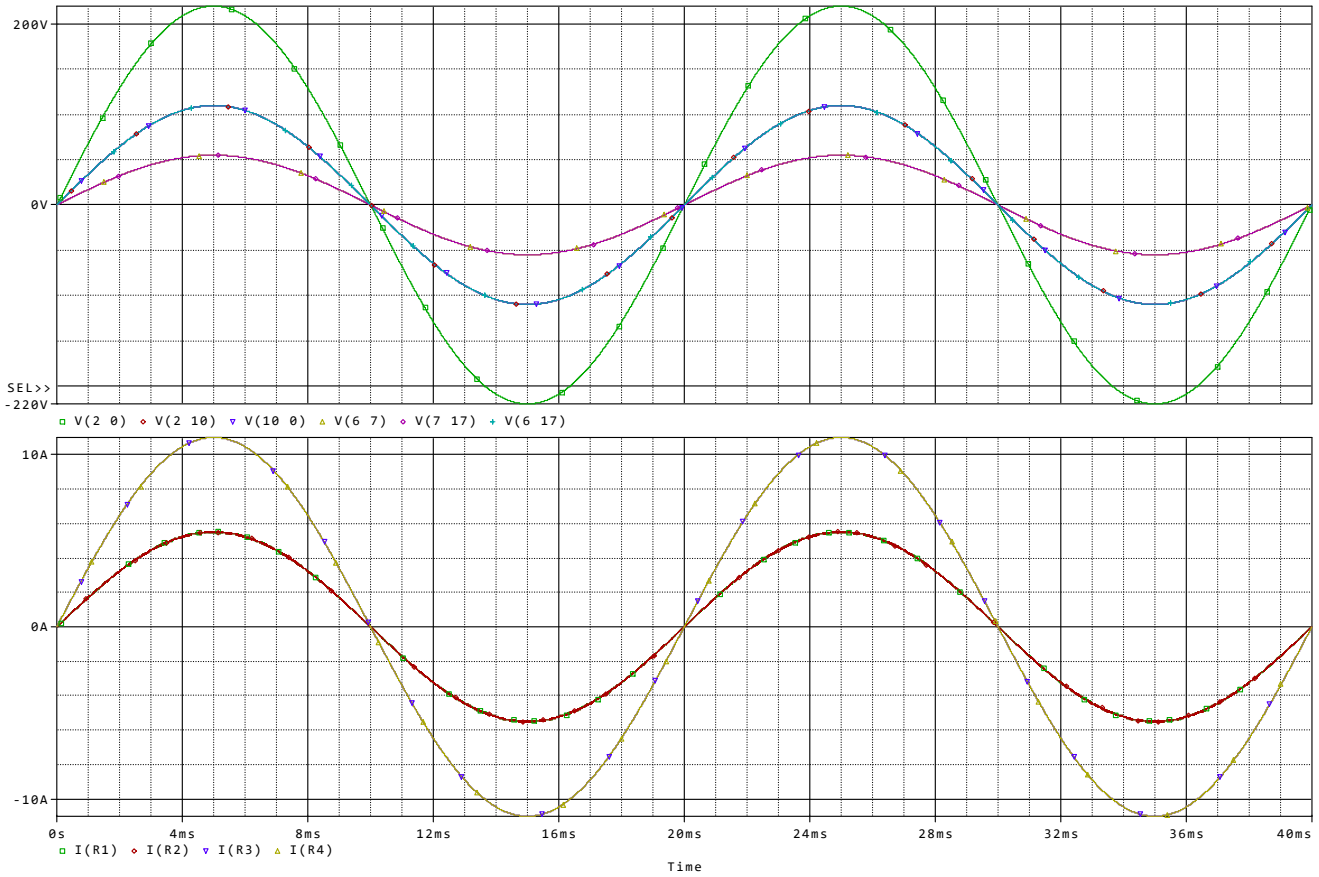

Fig. 5 (c) PSPICE plot of voltages and currents of series-series step-down transformer (gain 0.5)

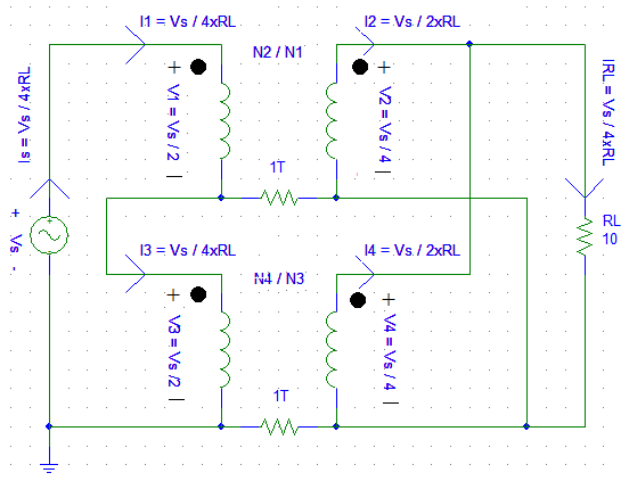

Fig. 6 (a) Equivalent circuit of the series-parallel step-down transformer

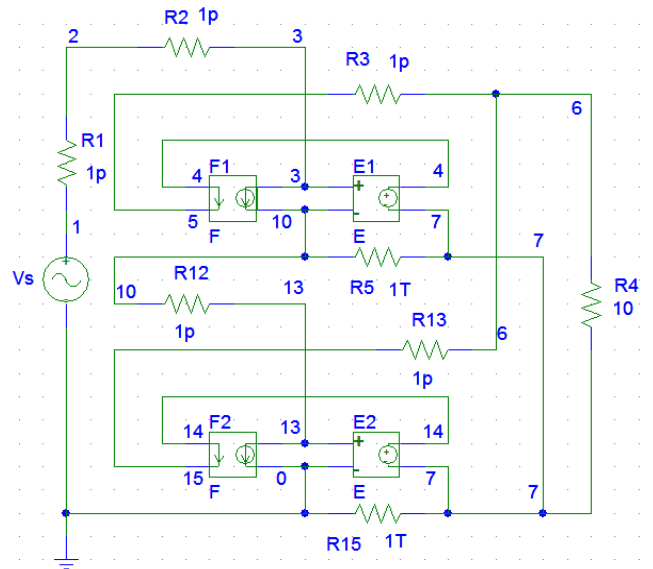

Fig. 6 (b) Schematic of the series-series step-down transformer

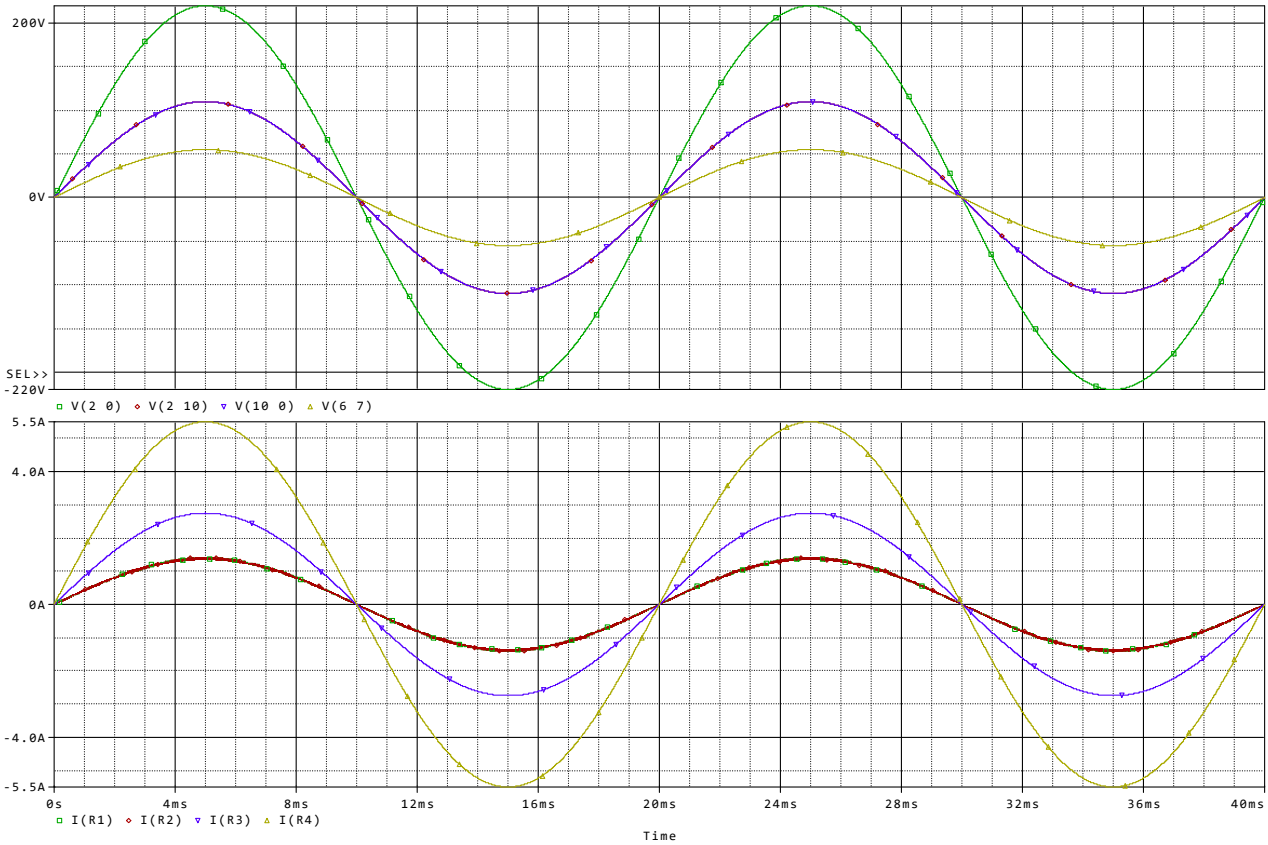

Fig. 6 (c) PSpice plot of voltages and currents of series-series step-down transformer (gain 0.5)

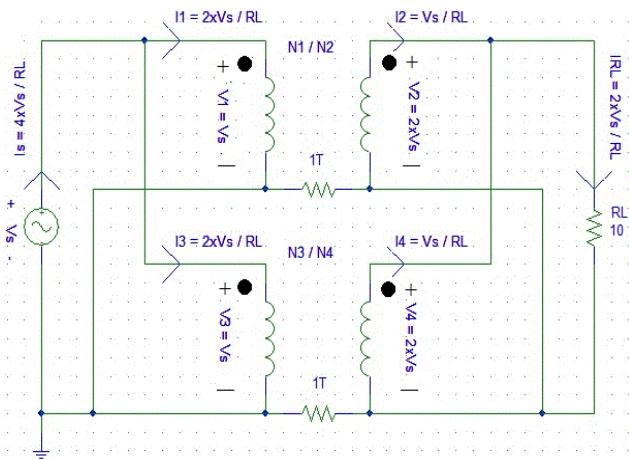

Fig. 7 (a) Equivalent circuit of the parallel-parallel step-up transformer

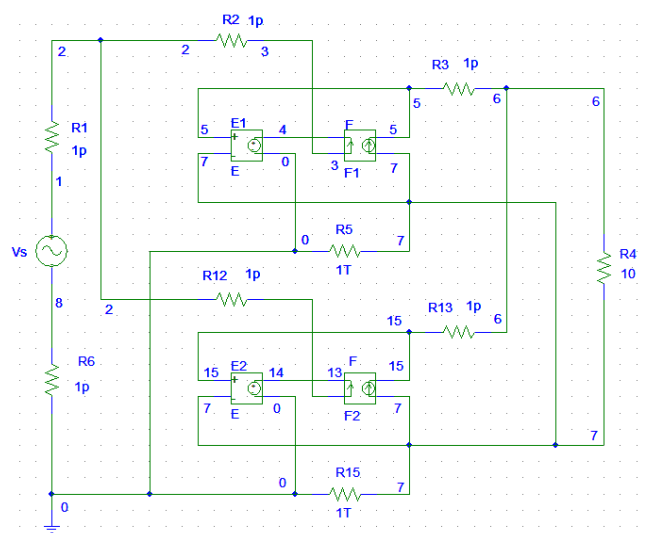

Fig. 7 (b) Schematic of the parallel-parallel step-up transformer

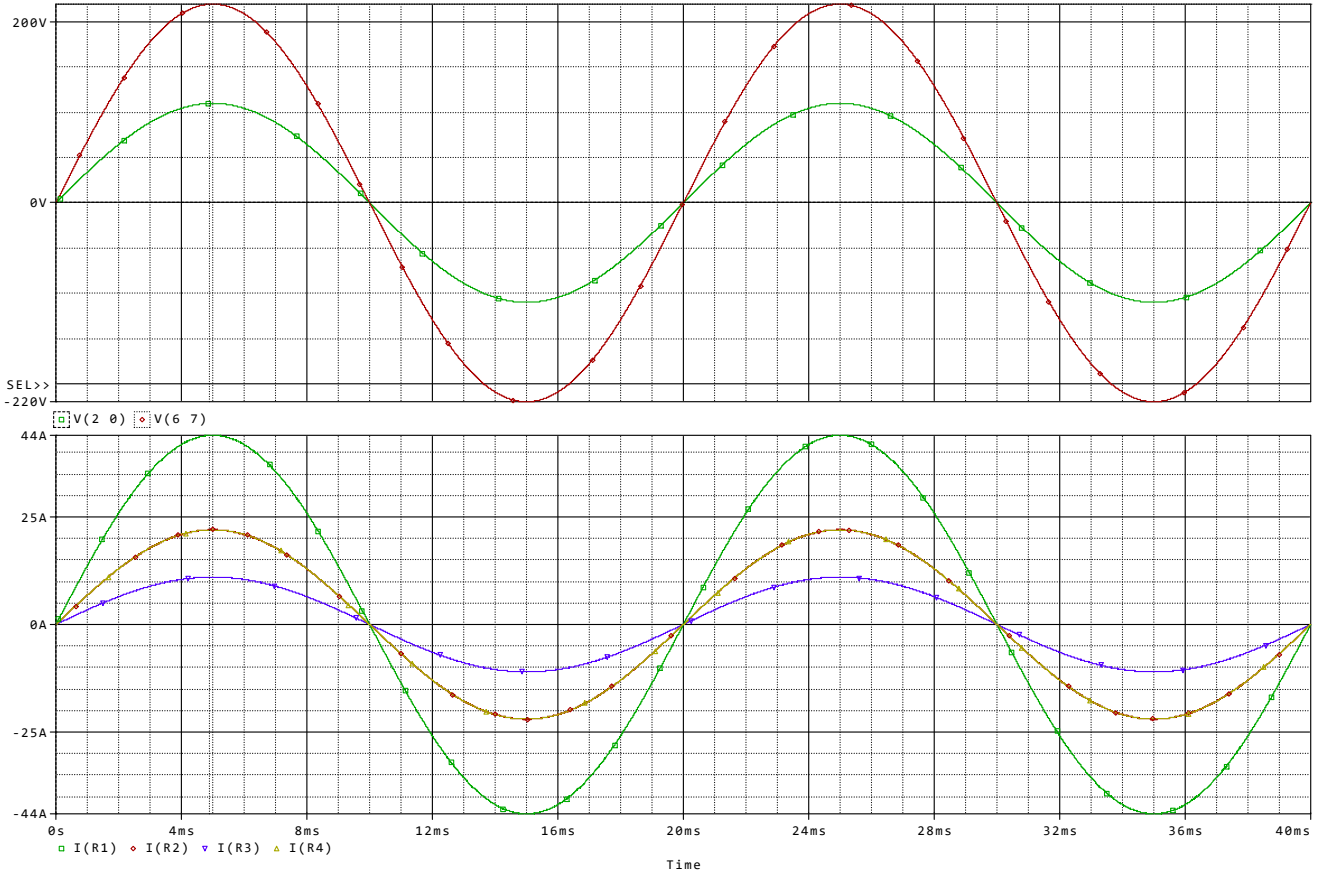

Fig. 7 (c) PSpice plot of voltages and currents of parallel- parallel step-up transformer (gain 0.5)

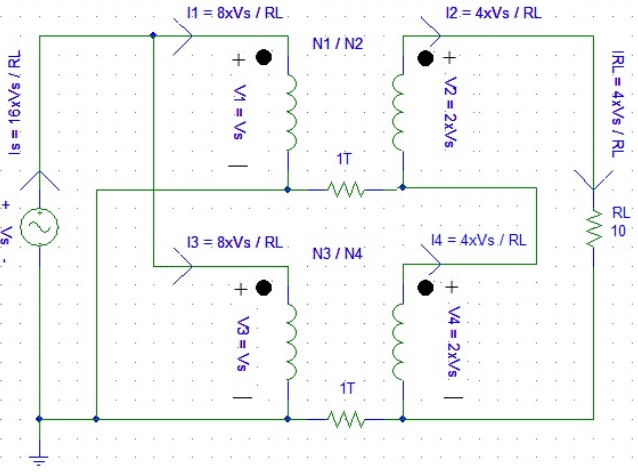

Fig. 8 (a) Equivalent circuit of the parallel-series step-up transformer

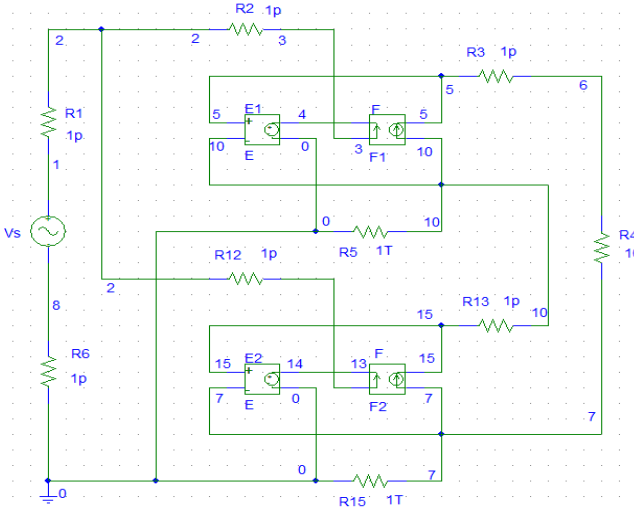

Fig. 8 (b) Schematic of the parallel-series step-up transformer

Open Science Index, Electrical and Computer Engineering Vol:11, No:9, 2017 publications.waset.org/10007836.pdf

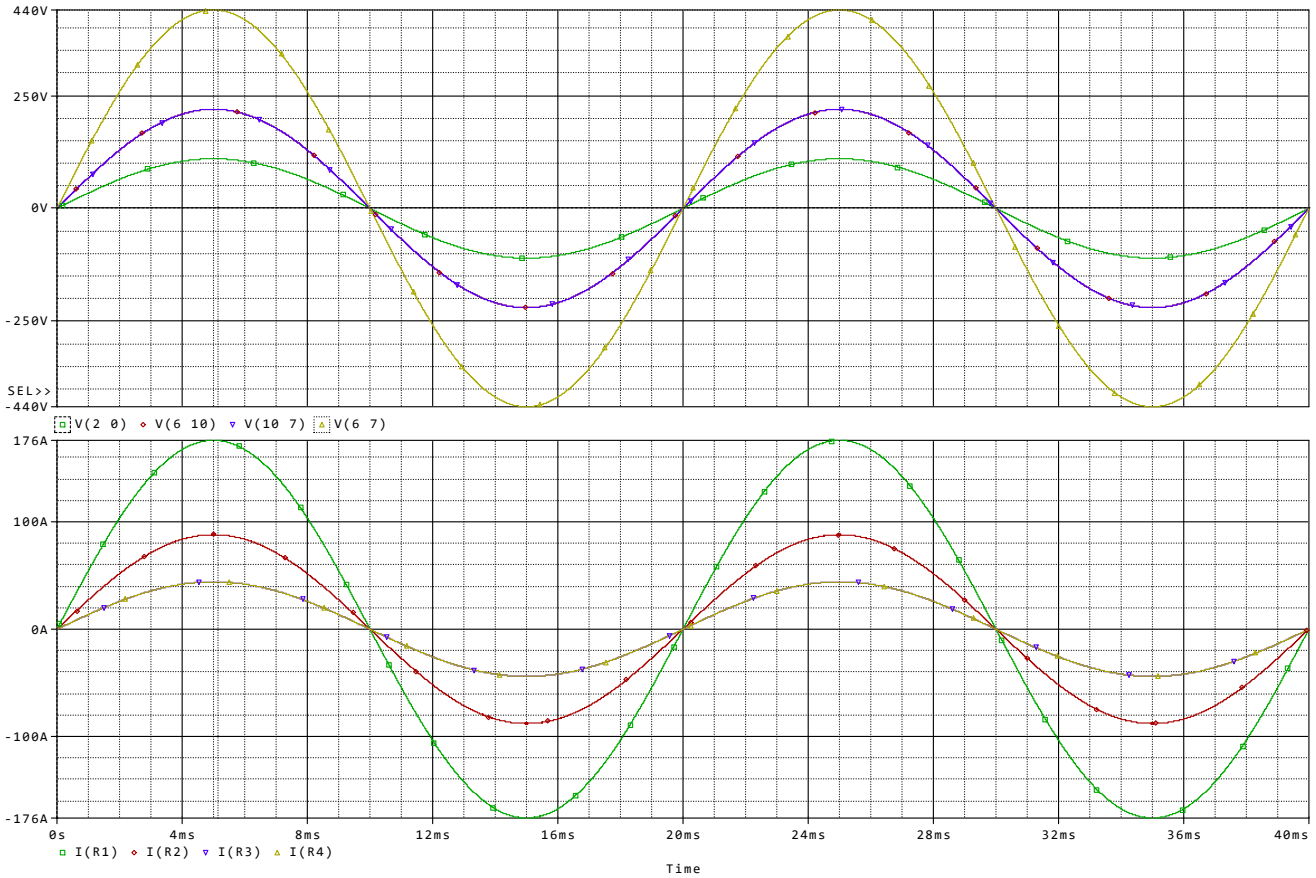

Fig. 8 (c) PSpice plot of voltages and currents of parallel-series step-up Transformer (gain 0.5)

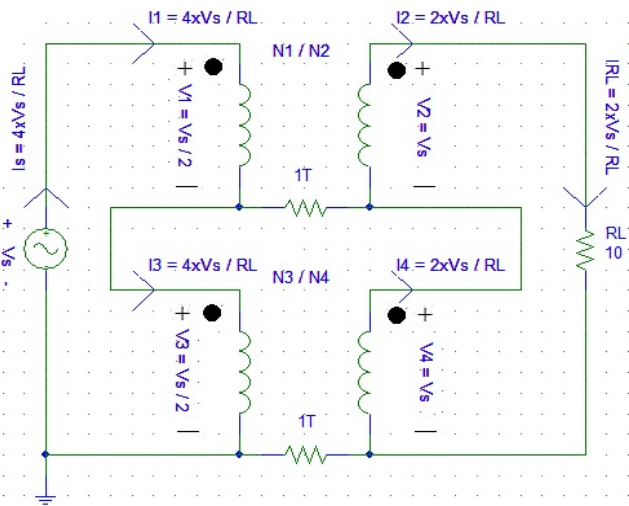

Fig. 9 (a) Equivalent circuit of the series-series step-up transformer

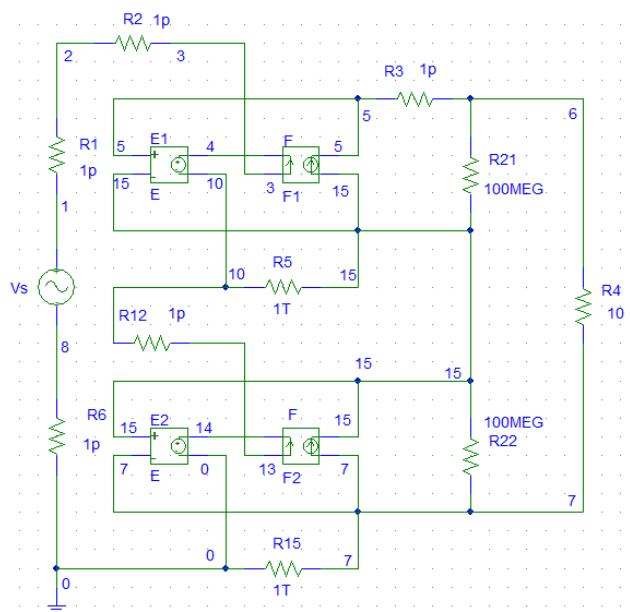

Fig. 9 (b) Schematic of the series-series step-up transformer



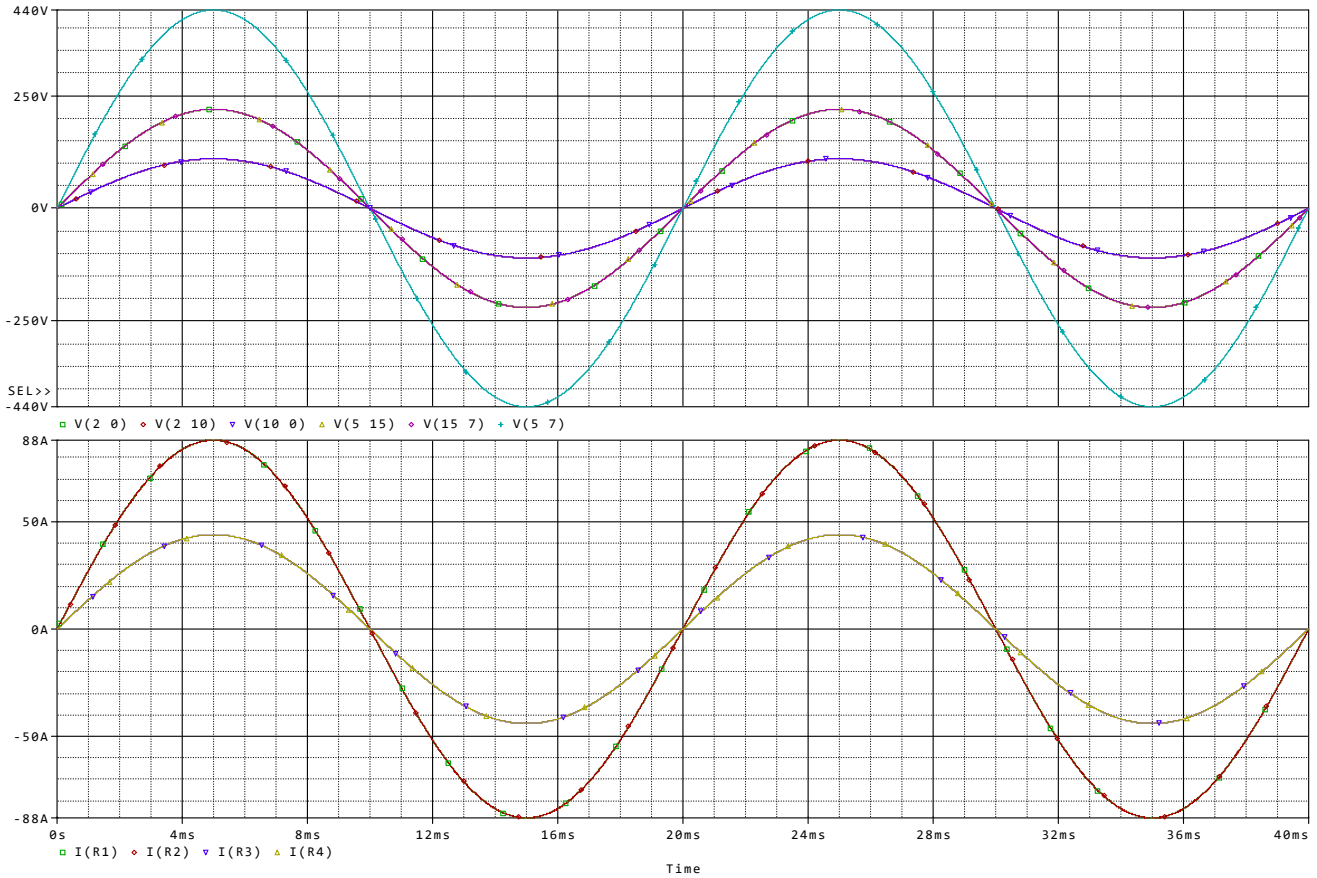

Fig. 9 (c) PSpice plot of voltages and currents of series-series step-up Transformer (gain 0.5)

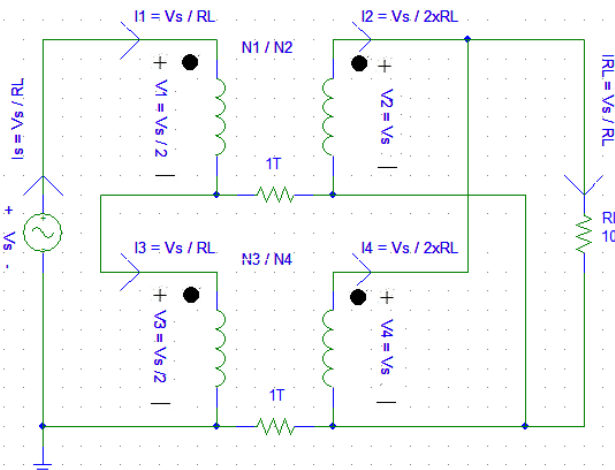

Fig. 10 (a) Equivalent circuit of the series-parallel step-up transformer

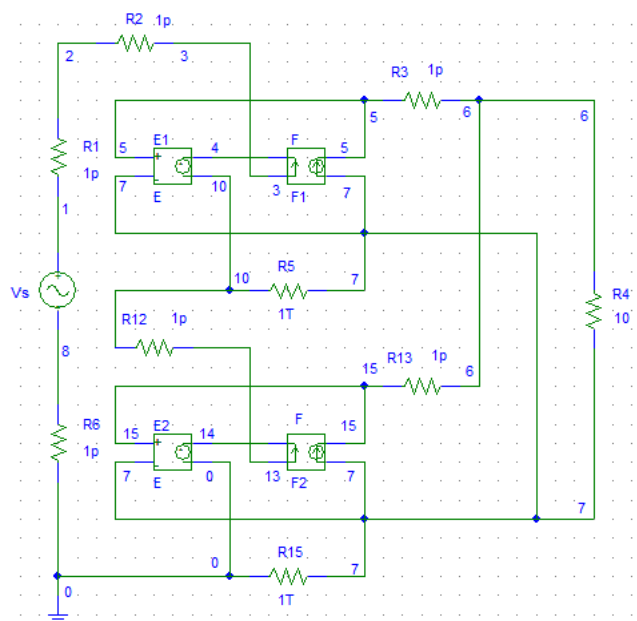

Fig. 10 (b) Schematic of the series-parallel step-up transformer

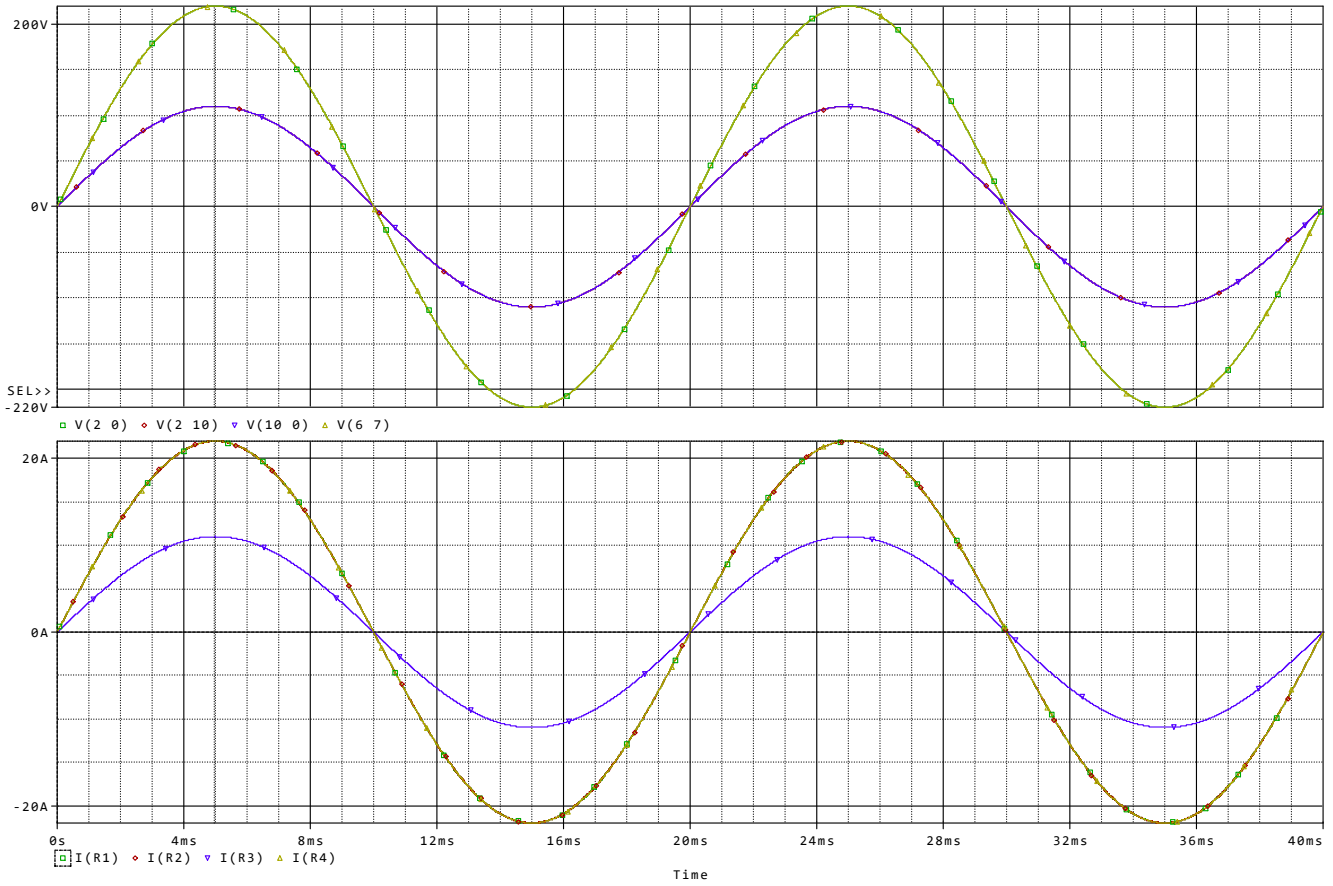

Fig. 10 (c) PSpice plot of voltages and currents of series-series step-up transformer (gain 0.5)

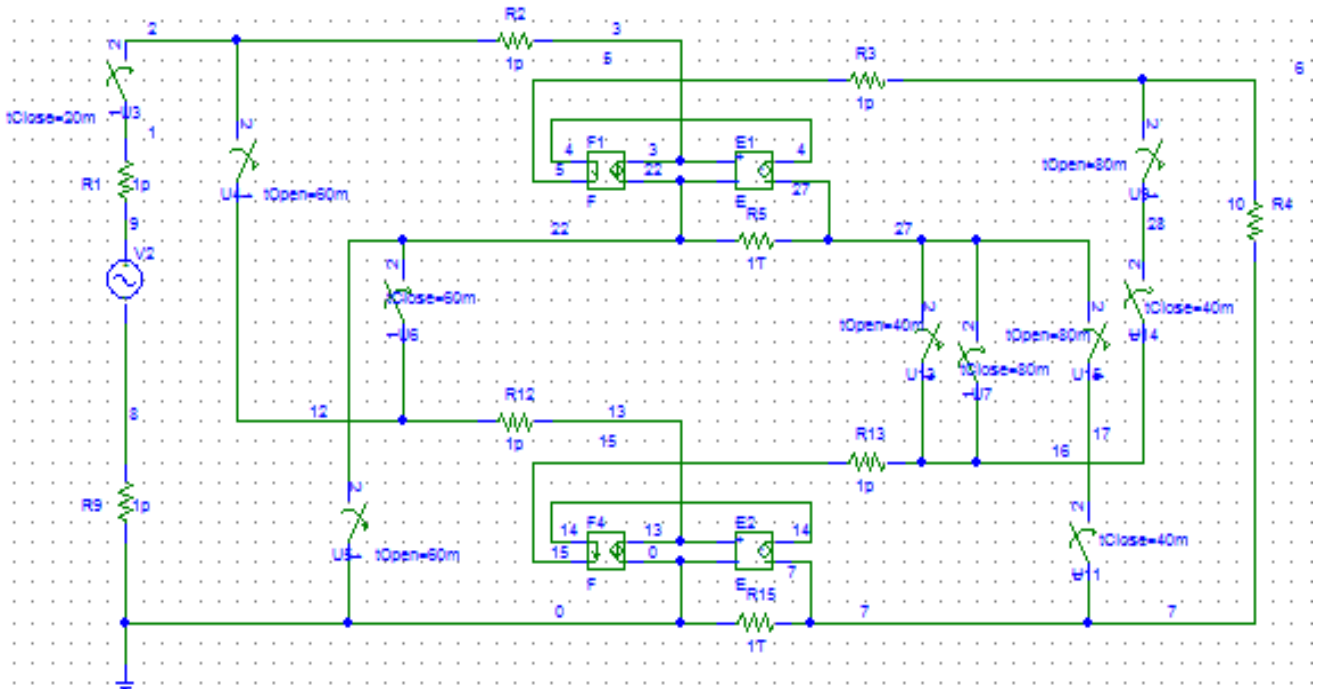

Fig. 11 (a) The PSpice modelling four different connection step-down transformer

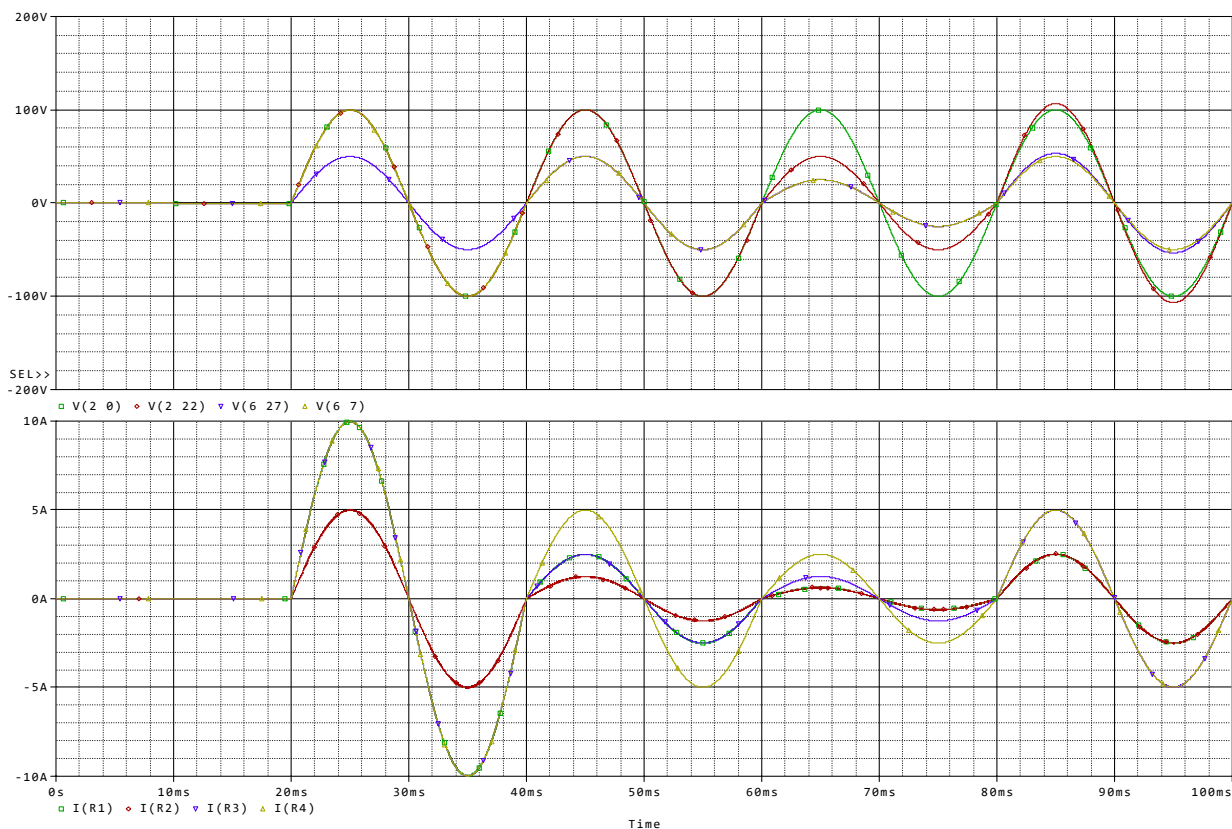

Fig. 11 (b) Voltages and Currents of step-down Transformer with gain 0.5

### III. CONCLUSION

In this paper, eight possible different transformer connections have been simulated by PSpice program. The obtained calculated and simulated values were compared and validated. As shown in this paper, PSpice could be used easily for obtaining the same results that could be obtained from computation. Due to the practical nominal power of autotransformer, the input voltage and input current have been decreased. The results of this paper could be used in power laboratories for education purpose. Parallel-parallel step-down transformer

$$V_1 = V_3 = V_s = 220V \quad (1)$$

$$V_2 = V_4 = V_{R_L} = \frac{V_s}{2} = 110V \quad (2)$$

$$I_{R_L} = \frac{V_s}{2xR_L} = 11A \quad (3)$$

$$I_2 = I_4 = \frac{V_s}{4xR_L} = 5.5A \quad (4)$$

$$I_1 = I_3 = \frac{V_s}{8xR_L} = 2.75A \quad (5)$$

$$I_s = \frac{V_s}{4xR_L} = 5.5A \quad (6)$$

Parallel-series step-down transformer

$$V_1 = V_3 = V_s = 220V \quad (7)$$

$$V_2 = V_4 = \frac{V_s}{2} = 110V \quad (8)$$

$$V_{R_L} = V_s = 220V \quad (9)$$

$$I_{R_L} = I_2 = I_4 = \frac{V_s}{R_L} = 11A \quad (10)$$

$$I_1 = I_3 = \frac{V_s}{2xR_L} = 5.5A \quad (11)$$

$$I_s = \frac{V_s}{R_L} = 11A \quad (12)$$

Series-series step-down transformer

$$V_1 = V_3 = \frac{V_s}{2} = 110V \quad (13)$$

$$V_2 = V_4 = \frac{V_s}{4} = 55V \quad (14)$$

$$V_{R_L} = \frac{V_s}{2} = 110V \quad (15)$$

$$I_{R_L} = I_2 = I_4 = \frac{V_s}{2 \times R_L} = 11A \quad (16)$$

$$I_1 = I_3 = I_s = \frac{V_s}{4 \times R_L} = 5.5A \quad (17)$$

#### Series-parallel step-down transformer

$$V_1 = V_3 = \frac{V_s}{2} = 110V \quad (18)$$

$$V_2 = V_4 = V_{R_L} = \frac{V_s}{4} = 55V \quad (19)$$

$$I_{R_L} = \frac{V_s}{4 \times R_L} = 5.5A \quad (20)$$

$$I_2 = I_4 = \frac{V_s}{2 \times R_L} = 11A \quad (21)$$

$$I_1 = I_3 = I_s = \frac{V_s}{4 \times R_L} = 5.5A \quad (22)$$

#### Parallel-parallel step-up transformer

$$V_1 = V_3 = V_s = 55V \quad (23)$$

$$V_2 = V_4 = V_{R_L} = 2 \times V_s = 110V \quad (24)$$

$$I_{R_L} = \frac{2 \times V_s}{R_L} = 11A \quad (25)$$

$$I_2 = I_4 = \frac{V_s}{R_L} = 5.5A \quad (26)$$

$$I_1 = I_3 = \frac{2 \times V_s}{R_L} = 11A \quad (27)$$

$$I_s = \frac{4 \times V_s}{R_L} = 22A \quad (28)$$

#### Parallel-series step-up transformer

$$V_1 = V_3 = V_s = 13.75V \quad (29)$$

$$V_2 = V_4 = 2 \times V_s = 27.5V \quad (30)$$

$$V_{R_L} = 4 \times V_s = 55V \quad (31)$$

$$I_{R_L} = I_2 = I_4 = \frac{4 \times V_s}{R_L} = 5.5A \quad (32)$$

$$I_1 = I_3 = \frac{8 \times V_s}{R_L} = 11A \quad (33)$$

$$I_s = \frac{16 \times V_s}{R_L} = 22A \quad (34)$$

#### Series-series step-up transformer

$$V_1 = V_3 = \frac{V_s}{2} = 13.75V \quad (35)$$

$$V_2 = V_4 = V_s = 27.5V \quad (36)$$

$$V_{R_L} = \frac{2 \times V_s}{2} = 55A \quad (37)$$

$$I_{R_L} = I_2 = I_4 = \frac{2 \times V_s}{R_L} = 5.5A \quad (38)$$

$$I_1 = I_3 = I_s = \frac{4 \times V_s}{R_L} = 11A \quad (39)$$

#### Series-parallel step-up transformer

$$V_1 = V_3 = \frac{V_s}{2} = 55V \quad (40)$$

$$V_2 = V_4 = V_{R_L} = V_s = 110V \quad (41)$$

$$I_{R_L} = \frac{V_s}{R_L} = 11A \quad (42)$$

$$I_2 = I_4 = \frac{V_s}{2 \times R_L} = 5.5A \quad (43)$$

$$I_1 = I_3 = I_s = \frac{V_s}{R_L} = 11A \quad (44)$$

#### REFERENCES

- [1] Vallamkonda Sankar, (November 19, 2012), "Preparation of Transformer Specifications", IEEE Southern Alberta (SAS)- IEEE PES- IAS Seminar. on.
- [2] A. C. Franklin, D. P. Franklin, "The J&P Transformer Book", Aditya books private limited, New Delhi, pp-1-12, 1995.
- [3] R. Singuor, P. Solanki, N. Pathak, D. Suresh Babu, (April 2012), "Simulation of Single Phase Transformer with Different Supplies", International Journal of Scientific and Research Publications, Volume 2, Issue 4, pp 1-5.
- [4] B. L. Theraja and A. K. Theraja, "A Textbook of Electrical Technology Vol II", S. Chand publishers, Eighth Edition, 2005.
- [5] M. S. Taci, I. Döşeyen, H. Gorgun "Determining the Harmonic Effects of Nonlinear Loads on Parallel Connected Transformers in Terms of Power Factor", "Power Quality '98", Hyderabad, India. 1998.
- [6] D. Treballe, B. Valecillos, "Optimal Operation of Paralleled Power Transformers", International Conference on Renewable Energies and Power Quality, Santandar, Spain, 2008.
- [7] M. S. Taci, I. Döşeyen "Determining the Harmonic Components of Non-linear Impedance Loads in Term Resistances and Reactances by Using a Current Harmonic Method", 9th. Mediterranean Electrotechnical Conference, MELECON 98, vol.2, pp. 1000 – 1003, 1998.
- [8] E. T. Jaun, "Advanced Transformer Paralleling", Rural Electric Power Conference, pp, B5/1 - B5/6, 2001.
- [9] G. Calzolari, C. Saldaria "Power Transformers in Parallel Which Share a Neutral Resistance: How to Manage the Circulating Current Between the Secondary Windings", International Conference on Power Systems Transients (IPST), 2005.
- [10] Y. C. Kang, M. S. Lee, B. E. Lee, S. I. Jang "Estimation of the Circulating Currents in the Parallel Operation of Transformers", The International Conference on Electrical Engineering, Okinawa, Japan, 2008.