

Removal of Total Petroleum Hydrocarbons from Contaminated Soils by Electrochemical Method

D. M. Cocârță, I. A. Istrate, C. Streche, D. M. Dumitru

Open Science Index, Environmental and Ecological Engineering Vol:11, No:5, 2017 publications.waset.org/10007754.pdf

Abstract—Soil contamination phenomena are a wide world issue that has received the important attention in the last decades. The main pollutants that have affected soils are especially those resulted from the oil extraction, transport and processing. This paper presents results obtained in the framework of a research project focused on the management of contaminated sites with petroleum products/ REMPET. One of the specific objectives of the REMPET project was to assess the electrochemical treatment (improved with polarity change respect to the typical approach) as a treatment option for the remediation of total petroleum hydrocarbons (TPHs) from contaminated soils. Petroleum hydrocarbon compounds attach to soil components and are difficult to remove and degrade. Electrochemical treatment is a physicochemical treatment that has gained acceptance as an alternative method, for the remediation of organic contaminated soils comparing with the traditional methods as bioremediation and chemical oxidation. This type of treatment need short time and have high removal efficiency, being usually applied in heterogeneous soils with low permeability. During the experimental tests, the following parameters were monitored: pH, redox potential, humidity, current intensity, energy consumption. The electrochemical method was applied in an experimental setup with the next dimensions: 450 mm x 150 mm x 150 mm (L x l x h). The setup length was devised in three electrochemical cells that were connected at two power supplies. The power supplies configuration was provided in such manner that each cell has a cathode and an anode without overlapping. The initial value of TPH concentration in soil was of 1420.28 mg/kg_{dw}. The remediation method has been applied for only 21 days, when it was already noticed an average removal efficiency of 31 %, with better results in the anode area respect to the cathode one (33% respect to 27%). The energy consumption registered after the development of the experiment was 10.6 kWh for exterior power supply and 16.1 kWh for the interior one. Taking into account that at national level, the most used methods for soil remediation are bioremediation (which needs too much time to be implemented and depends on many factors) and thermal desorption (which involves high costs in order to be implemented), the study of electrochemical treatment will give an alternative to these two methods (and their limitations).

Keywords—Electrochemical remediation, pollution, soil contamination, total petroleum hydrocarbons

I. INTRODUCTION

BETWEEN 2011 and 2012, the European Commission has identified the soil contamination as a priority for the collection of policy-relevant soil data at European level [1].

D. M. Cocârță, C. Streche, D. M. Dumitru are with University Politehnica of Bucharest, Faculty of Power Engineering, Department of Energy Production and Use, Splaiul Independentei no 313, Bucharest, Romania (e-mail: dmcocarta@gmail.com, constantin_streche@yahoo.com, delia.micaela@yahoo.com).

I.A. Istrate is with the University Politehnica of Bucharest, Faculty of Biotechnical Systems Engineering, Department of Biotechnical Systems Splaiul Independentei 313, Bucharest, Romania, (e-mail: ia_istrate@yahoo.com).

According to available data, at European level, the number of estimated potential contaminated sites is more than 2.5 million and the identified contaminated sites around 342 thousand [1]. In literature, according to [1], it is mentioned the fact that municipal and industrial wastes contribute most to soil contamination (38%) and it is followed by the industrial sector (34%). Mineral oil and heavy metals are the main contaminants contributing around 60% to soil contamination (Fig. 1) [1]. According to [1] the number of estimated potential contaminated sites is more than 2.5 million and the identified contaminated sites around 342 thousand. Soil contamination is recognized as one of the eight soil threats expressed in the thematic strategy and the proposed directive for soil.

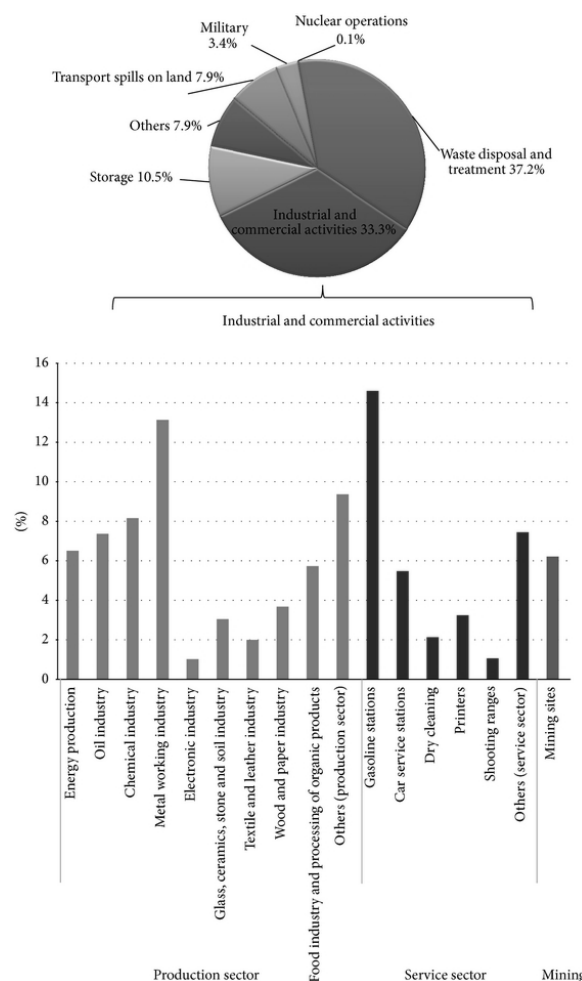

Fig. 1 Distribution of sectors contributing to soil contamination in Europe with special focus on the industrial/commercial activities [1]

The main factors that are responsible for the soil contamination are anthropogenic. In this category it can be included the main sectors of the economy, such as industry, transport, waste management and agriculture [2].

The present paper refers to the contamination with petroleum products which can be a consequence of petroleum transport, storage and refining, or accidents. After 1989, Romania took the last two decades through a major transition, where many companies and industries active in the socialist period were closed or were restructured. This period can be coupled with a decreased ability to remediate contaminated sites in order to reuse them.

In Romania, the highest number of potential contaminated sites is a result of the oil extraction industry (a total number of 215, according to the National Agency for Environmental Protection) and the highest number for contaminated sites, already identified, and is due to the activities of the same industry [3]-[5].

The results presented in this paper were obtained during the development of a research project, REMPET, which was focused on the treatment and management of contaminated sites by petroleum products. The project is implemented starting with 2015 until 2017 and one of the REMPET objectives was to evaluate an improved electrochemical treatment as an option for removing the total petroleum hydrocarbons (TPHs) from contaminated soils.

II. ELECTROCHEMICAL METHOD

A. Overview

The electrochemical method is a method that appeared in the last decades as a solution for inorganic contaminated soils. During the last years researches have been focused also on using the electrochemical treatment for organic contaminated soils. A wide range of methods for soil remediation are used all over the world as remediation with biological and physicochemical treatments, however, for the purpose of reducing time and increasing the scope of new technologies that have proven its viability in experimental laboratory tests later tested implemented on field are necessary [6]. One of the main advantages of electrochemical processes is the relatively short implementation time as well as its ease of removing contaminants in highly heterogeneous soils with low permeability [6]-[8].

The effectiveness of electrochemical remediation depends on many factors. There is a negative correlation between pH and the redox potential, and a high redox potential is good for oxidation reactions; thus, a low pH is conducive to electrochemical oxidation reactions [9]. In literature, it is mentioned that acidic conditions can enhance the electrochemical oxidation reaction. The strength of the electric current affects the electrochemical reaction rate and the overall performance of electrochemical remediation [9]. Also, the electrochemical oxidation rate increases with current density. In addition, the electric current itself is affected by the conductive capability, moisture content, and voltage.

B. Electrodes Distribution

Another important factor on which the effectiveness of electrochemical remediation depends is the electrodes positioning. The electrode distribution when electrochemical remediation is applied can vary from the bench scale to commercial installations as it is presented in Fig. 2.

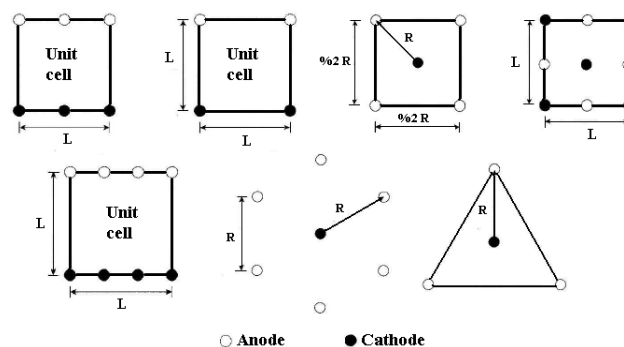

Fig. 2 Possible electrode distribution for the application of electrochemical remediation [10]

If the choice involves the rectangular configuration, the ineffective area should be calculated in order to observe from the economical point of view, but also from the treatment efficiency point of view (how many bars should an electrode network have) [11], [12]. This type of determination is presented in Fig. 3.

C. Principles and Phenomena

The electro-remediation (ER) process, also called electrokinetic electrochemical treatment and/or electro - claim among others [6], [13], [14], is a technique within physicochemical treatments. ER has been considered to be a promising process addressing problems such as heterogeneous soils and low permeability; it can be applied in situ or ex situ, and is especially useful for remediation of inaccessible sites with minimal disruption to the surface, where other technologies fail. Besides it is also sensitive to a wide variety of contaminants [6]. The application of electro-kinetic process is governed by electromigration and electro-osmosis with electrolysis reactions at the electrodes. During the application of electrochemical treatment apart the physical phenomena, some chemical phenomena also take place [2], [3]. In the anode part, there are oxidation reactions that can be observed whereas in the cathode part we have the reduction reactions. Regarding the pH, it can be noticed that in the anode part there is an acid front and in the cathode part there is a basic one. The tendency of the acid front is to move towards the basic one two times faster [3].

III. EXPERIMENTAL RESEARCH

A. Experimental Setup

The electrochemical method was applied in an experimental setup with dimensions of 450 mm x 150 mm x 150 mm (L x l x h). The experimental setup was divided in three areas, known as electrochemical cells, which were connected at two

power supplies (as shown in Fig. 4). The power supplies configuration was provided in such a manner so that each cell has a cathode and an anode without overlapping.

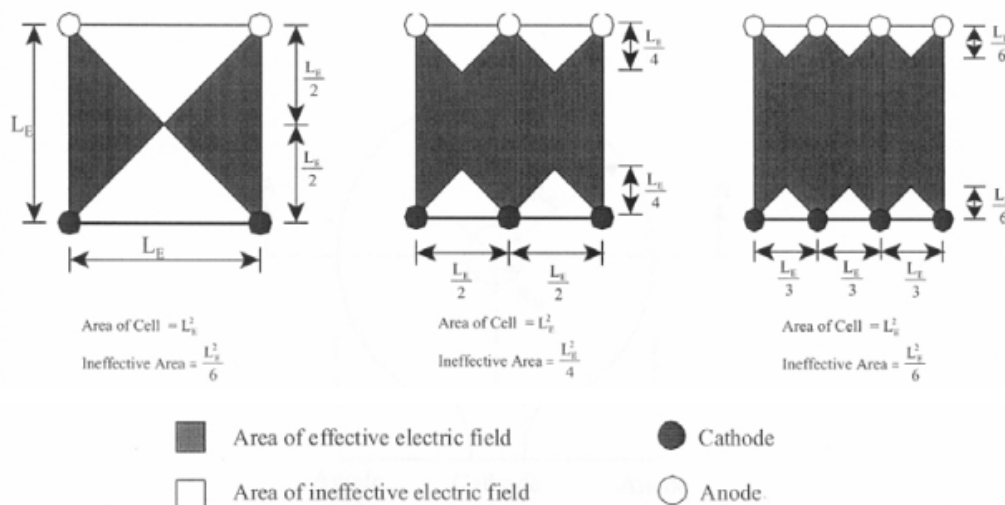

Fig. 3 The method for the determination of the inactive areas [12]



Fig. 4 Experimental setup used for the application of the electrochemical method

Prior to the beginning of the experiment, the soil was inserted in the electrochemical cells after the optimum humidity was obtained (not less than 20%). The humidity for the initial soil sample was 23.50%. The soil is compacted as best as it can be done in order to remove all the empty spaces.

B. Initial Characterization of Soil

Soil chemical analyses have been performed with an authorized laboratory. Before starting the experiment, a series of initial parameters were determined. The pH was around 8.20 (there is a weak tendency for the basification of the soil sample) whereas the total organic carbon (TOC) was 4.45 % d.w. (dry weight). The initial values of the soil, regarding the TPH are presented in Table I.

The pH, redox and temperature was taken in a soil/water suspension using sensors IQ SENSOR NET pH/ORP that were linked to a multi-parameter meter 2020XT (Fig. 5) purchased under a project co-financed in the framework of the Sectorial Operational Programme "Increase of Economic Competitiveness" POSCCE-A2-O2.1.2.-2009-2, RECOLAND ID519, SMIS-CSNR: 11982, Nb. 182/18.06.2010 (2010-2013).

Also, the energy consumption was measured in real time by using an electronic power meter model KGS 02-01/1109 (as shown in Fig. 6).

TABLE I
INITIAL CHARACTERIZATION OF SOIL SAMPLE [MG/KG_{dw}]

Analyzed parameter	Determined values
Total PAH	1.239
Naphthalene	0.033
Acenaphthene	0.240
Fluorene	0.023
Phenanthrene	0.011
Anthracene	0.002
Fluoranten	0.010
Pyrene	0.070
Benzo-a-anthracene	0.172
Chrysene	0.123
Benzo-b-fluoranten	0.116
Benzo-k-fluoranten	0.020
Benzo-a-pyrene	0.115
Dibenzo-a,h-anthracene	0.176
Benzo-ghi-perylene	0.030
Indeno(1,2,3-cd) pyrene	0.098
Benzene	<0.25
Toluene	<0.25
Etilbenzene	<0.25
O-xylene	<0.25
M+P - xylene	0.775

C. Experimental Test

The research was performed in the frame of a research project focused on the management of contaminated sites with petroleum products/ REMPET. The idea of the research project was to see if the electrochemical treatment can be considered as an option for the treatment of contaminated soils with petroleum products.

The experiment lasted for 21 days, and the monitoring was done daily (except the weekends). The applied voltage was of 30 V and it was constant during the experiment. This voltage corresponds to a specific voltage of 1 V/cm.

The contaminated soil was inserted in all three cells (as it

can be seen in Fig. 8) that were linked to the two power supplies. During this test, the following parameters were monitored: pH, electric current, redox potential (ORP), energy consumption and pollutant concentrations (individual hydrocarbons, total petroleum hydrocarbons, total organic carbon).

The variation of the pH depends on the area where it is measured. In the cathode part, the tendency is to have a basic pH whereas in the anode part an acid one. The variation of the pH in all three cells was between 6.05 and 11.43.



Fig. 5 The multi-parameter meter used for the monitoring of the pH, redox potential, and temperature



Fig. 6 Monitoring the energy consumption by using the electronic power meter

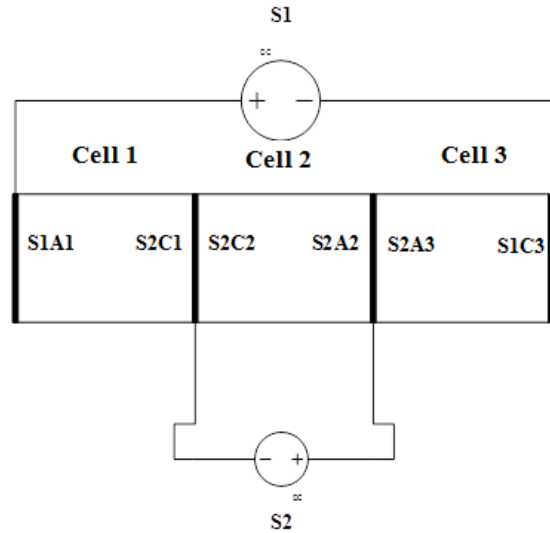

Fig. 7 Cell and electrodes distribution (S1 – first power supply, S2 – second power supply, A1 and C1 – anode and cathode for the first cell, A2 and C2 - anode and cathode for the second cell, A3 and C3 - anode and cathode for the third cell)

Another parameter that was monitored was the current; this had a variation from 0.03 A up to 0.11 A (for the first power supply) and 0.5 and 0.22 (for the second power supply). The maximum value (for both power supplies) was reached at the beginning of the test. After, a decrease of the current was registered and the tendency was to reach a steady state value.

A third very important parameter that was monitored it was the ORP. The identified values have given us the information regarding the oxidation reactions (which we wanted to stimulate as much as possible) and reduction reactions. When the values for ORP were near the value of 0 mV or even smaller, the experiment potential was changed (the anode became cathode and vice versa), as shown in Fig. 8.

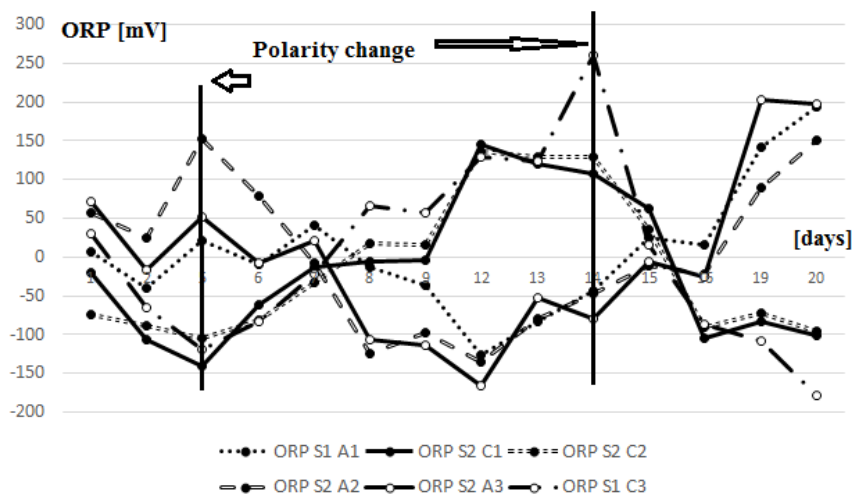

Fig. 8 ORP variation in time

After 21 days of electrochemical treatment, the obtained results were quite promising (as shown in Fig. 9). The same kinds of results were achieved as mentioned in literature, according to [3] and [11], where it was demonstrated that the treatment efficiency is increasing in time.

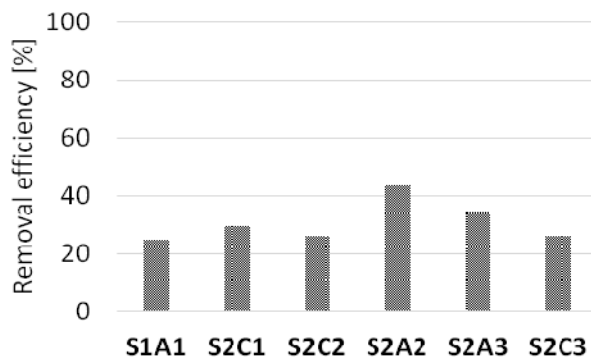

Fig. 9 Removal efficiency of TPHs from contaminated soil achieved after 21 days of electrochemical treatment

The energy consumption registered after the development of the experimental study was 10.6 kWh for exterior power supply and 16.1 kWh for the interior one. The highest value of the energy consumption was reached also due to the high values that were registered for the current (maximum of 0.22 A for the second power supply comparing with 0.11 A for the first one).

IV. CONCLUSION

The problematic of contaminated sites has become a quite huge one during the last decades as concluded by the inventories that were done in the European Countries (and not only there). The concept of sustainability is implemented in every area, and because of that when a remediation system is implemented, an important aspect that is observed is the sustainability of the results. The overlapping interests and divergent expectations of stakeholders in the remediation of the contaminated sites form a complex web of shared concerns. Usually there are two parts: the affected public wants to "fix the problem irrespective of cost," whereas technology users wish to "fix the problem at the lowest possible cost".

With regard to the experimental study involving the electrochemical method, it was observed the tendency that soil has to acidify in the anode part; this fact helps the oxidation reactions which will involve higher removal efficiency in that area. That is why in the soil that corresponds to S2A2, we have higher removal efficiency, even though we changed the polarity.

So, in the present work a different approach for electrode configuration was experimented in order to observe if a smaller number of power supplies could be used for the same number of electrochemical cells. This could be a great opportunity for the application at a real scale of this kind of treatment as good results in terms of decontamination degree were achieved.

ACKNOWLEDGMENT

This work was supported by a grant of the Romanian National Authority for Scientific Research and Innovation CNC – UEFISCDI, project number PN-II-RU-TE-2014-4-2348 and University POLITEHNICA of Bucharest, through the "Excellence Research Grants" Program, UPB – GEX. Identifier: UPB–EXCELENȚĂ–2016, Research project title: Utilizarea ozonului în tratarea solurilor contaminate organic/The use of ozone for the treatment of organic contaminated soils, Contract number 42/26.09.2016 (acronym: OZOSOL).

REFERENCES

- [1] P. Panagos, M. Van Liedekerke, Y. Yigini, L. Montanarella "Contaminated Sites in Europe: Review of the Current Situation Based on Data Collected through a European Network", *Journal of Environmental and Public Health* Volume 2013, Article ID 158764, 11 pages <http://dx.doi.org/10.1155/2013/158764>.
- [2] J. Stolte, M. Tesfai, L. Øygarden, S. Kværnø, J. Keizer, F. Verheijen P. Panagos, C. Ballabio, R. Hessel, "Soil threats in Europe, Status, methods, drivers and effects on ecosystem services", *JRC Technical report*, 2016 (http://digital.csic.es/bitstream/10261/127158/1/Anaya-et-al_2016_JRC-Soil-contamination.pdf).
- [3] I.A. Istrate, M. N. Dincă, M. Ferdeș, D. M. Cocârță, "The use of ozone in combination with electrochemical treatment for the remediation of organic polluted soils", *Proc. 45 Symposium "Actual Tasks on Agricultural Engineering"*, Croatia, 2017, pp 65-73.
- [4] I.A. Istrate; D.M. Cocârță; S. Neamtu, S.; T. Cirlor, "The assessment of an alternative treatment for PCB polluted soils in the romanian context-bench scale tests", *Water Air Soil Pollut.* 2013, 224, 1516.
- [5] E. Ferrarese; G. Andreottola; I.A. Oprea, Remediation of PAH-contaminated sediments by chemical oxidation. *J. Hazard. Mater.* 2008, 152, pp.128–139.
- [6] M. Pérez-Corona, Z. Plank, E. Bustos, *Chapter 15, The Electrokinetic Treatment of Polluted Soil by Hydrocarbon: From Laboratory to Field- "Soil Contamination - Current Consequences and Further Solutions"*, book edited by Marcelo L. Larramendy and Sonia Soloneski, ISBN 978-953-51-2816-8, Print ISBN 978-953-51-2815-1,
- [7] D.M. Cocârță, D.M.; S. Neamtu, S.; A.R. Deac, Carcinogenic risk evaluation for human health risk assessment from soils contaminated with heavy metals. *Int. J. Environ. Sci. Technol.* 2016, 13, 2025–2036
- [8] K.R. Reddy, C. Cameselle, *Electrochemical Remediation Technologies for Polluted Soils, Sediments and Groundwater.*, John Wiley & Sons, Inc. 2009
- [9] S. Xu, S. Guo, B. Wu, F. Li, T. Li, *An assessment of the effectiveness and impact of electrokinetic remediation for pyrene-contaminated soil*, Volume 26, 2014, Pages 2290-2297.
- [10] A. De Battisti, Electrochemical remediation, Seminar "Dall'Emergenza delle bonifiche ad una gestione consapevole del territorio", Provincia Autonoma di Trento, 3-4 July 2008.
- [11] D.M. Cocârță; E.C. Rada, M. Ragazzi, A. Badea, T. Apostol, A contribution for a correct vision of health impact from municipal solid waste treatments. *Environ. Technol.* 2009, 30, 963–968.
- [12] A.N. Alshwabkeh, T.C. Sheahan, X. Wu, "Coupling of electrochemical and mechanical processes in soils under DC fields", *Mech. Mater.*, vol.36, 2004, pp. 453-465.
- [13] C. Cojocaru, D. M. Cocârță, I. A. Istrate, I. Crețescu Graphical Methodology of Global Pollution Index for the Environmental Impact Assessment Using Two Environmental Components, *Sustainability* 2017, 9(4), 593
- [14] I. Istrate, D. Cocârță, S. Neamtu, T. Cirlor, The assessment of an alternative treatment for PCB polluted soils in the romanian context - bench scale tests, *Water air and soil pollution*, vol 224 (4):1516.