

Highly Linear and Low Noise AMR Sensor Using Closed Loop and Signal-Chopped Architecture

N. Hadjigeorgiou, A. C. Tsalikidou, E. Hristoforou, P. P. Sotiriadis

Abstract—During the last few decades, the continuously increasing demand for accurate and reliable magnetic measurements has paved the way for the development of different types of magnetic sensing systems as well as different measurement techniques. Sensor sensitivity and linearity, signal-to-noise ratio, measurement range, cross-talk between sensors in multi-sensor applications are only some of the aspects that have been examined in the past. In this paper, a fully analog closed loop system in order to optimize the performance of AMR sensors has been developed. The operation of the proposed system has been tested using a Helmholtz coil calibration setup in order to control both the amplitude and direction of magnetic field in the vicinity of the AMR sensor. Experimental testing indicated that improved linearity of sensor response, as well as low noise levels can be achieved, when the system is employed.

Keywords—AMR sensor, closed loop, memory effects, chopper, linearity improvement, sensitivity improvement, magnetic noise, electronic noise.

I. INTRODUCTION

MAGNETIC sensors are preferred types of sensors in industry for many applications. They can easily operate under severe environmental conditions, they are very reliable due to the absence of moving parts, they can be imbedded inside building materials, and they can operate at elevated temperatures.

Magnetic sensors are categorized primarily based on their sensing principle which impacts directly their operating characteristics like measurement range, obtained resolution, frequency response, working temperature, and manufacturing cost. For example, Hall effect and pick-up-coils based sensors have been proven to be quite practical and cost effective solutions in most common applications. Nevertheless, pick up coils are not appropriate for measuring low frequency magnetic fields, while Hall-effect devices cannot provide the resolution levels needed in demanding applications. On the other hand, Anisotropic Magnetoresistance (AMR), Giant Magnetoresistance (GMR), Giant Magneto-Impedance (GMI), Magnetostrictive and Flux-Gate sensors, although available at an increased cost, are frequently employed when higher resolution is required [1].

N. Hadjigeorgiou is with the School of Electrical and Computer Engineering, National Technical University of Athens (NTUA), Athens, Greece (phone: +302107721482, fax: +302107721484, e-mail: nhatzig@central.ntua.gr).

A. C. Tsalikidou and P. P. Sotiriadis are with the School of Electrical and Computer Engineering, NTUA, Athens, Greece (e-mail: anastasitsalik@gmail.com, pps@ieec.com).

E. Hristoforou, was with School of Mining and Metallurgical Engineering. Now he is with the School of Electrical and Computer Engineering, NTUA, Athens, Greece (e-mail: eh@mental.ntua.gr).

AMR sensors have emerged as a promising alternative, when higher resolution is required, providing an ideal balance between performance and cost. They offer considerably improved frequency response compared to more expensive solutions, like Flux-Gates, and have been used successfully in a wide variety of applications ranging from navigation, detection of ferromagnetic elements and monitoring purposes to EMF and sensitive current measurements [2]-[4].

AMR sensors are typically formed in a Wheatstone bridge structure with bridge elements commonly manufactured by thin-film permalloy materials of magnetoresistive nature. The size of the bridge is often in tens of μm allowing for higher spatial resolution compared to more traditional solutions. Despite their advantages, contemporary AMR sensors still have certain deficiencies like non-linear response, DC offset, magnetic hysteresis, cross-axis effects and they need periodic re-polarization of permalloy film magnetic domains, which gives room for considerable improvement [5].

Several techniques have been proposed to enhance the performance of AMR sensors, e.g. elimination of DC offset using digital feedback and/or implementation of a current pulsing circuit to accomplish the re-polarization of permalloy thin-film magnetic domains are some of the most common approaches that have been adopted [3]-[5]. Hysteresis issues can also be controlled with the current pulsing circuit architecture. In addition, different numerical as well as experimental techniques have been proposed as a means of reducing cross-axis measurement effects regarding the response of the Wheatstone bridge elements [6]-[8]. However, certain issues such as non-linear response and measurement noise of AMR sensors are rarely discussed in architectures proposed in the literature. Moreover, while in most cases open loop feedback architectures are employed to improve the sensitivity of the magnetic measurement, this can lead to an increase in the uncertainty of measurement due to the corresponding increase of magnetic noise. In addition, the digital closed loop compensation systems proposed up to date tend to reduce the bandwidth of the closed loop.

In this work, an analog closed loop compensation system is proposed, developed, and tested as a means to eliminate the non-linearity of AMR response, considerably reduce the $1/f$ noise, and enhance the sensitivity of magnetic measurement. The experimental results indicate that AMR response presented a maximum deviation of 0.36% with respect to the ideal linear response. Furthermore, the proposed closed loop system is able to maintain the measured noise density levels as low as the corresponding intrinsic noise density values of the AMR sensing element provided by the manufacturer [9].

II. PROPOSED CLOSED LOOP ARCHITECTURE

For the purposes of this work, the HMC-1001 and 1002 AMR sensor elements, manufactured by Honeywell Inc., have been used. The structure of the proposed closed loop system is

illustrated in Fig. 1.

The system is composed of the AMR Wheatstone bridge sensor elements and the accompanying electronic circuitry, all of which are discussed in detail in the subsections “AMR Sensor Mathematical and SPICE Model”.

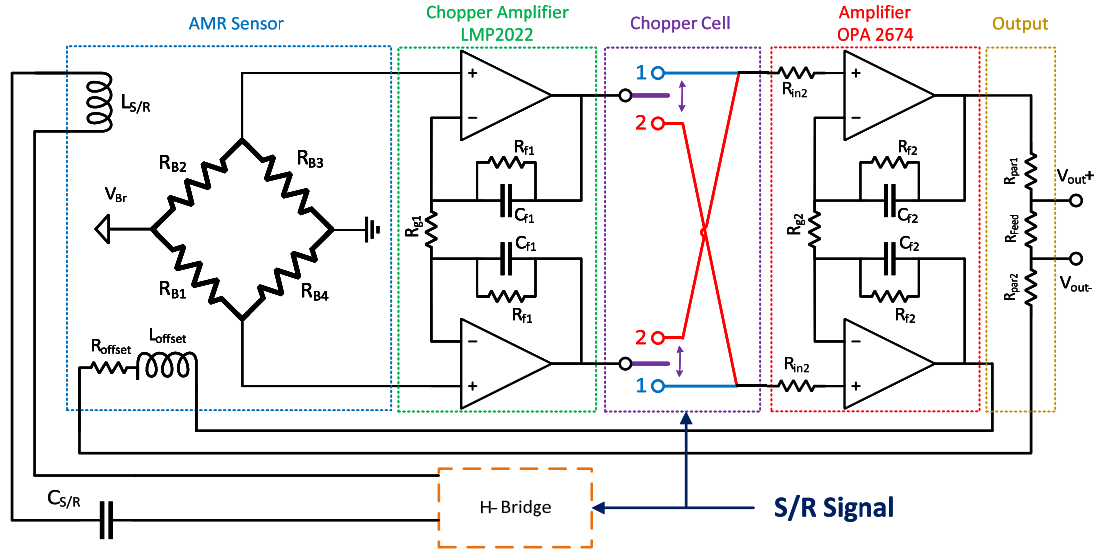

Fig. 1 The proposed closed loop architecture

There are two (integrated) coils in the AMR sensor. The bottom one, L_{offset} is used for feedback purposes to improve linearity and reduce memory effects. The top-left one, $L_{S/R}$, is the set-reset coil used for the re-polarization of permalloy thin-film magnetic domains with short but strong current pulses. Those pulses are generated by the H-Bridge switches using a capacitor in series. When a set pulse is given, the voltage output of the sensor is $F(B)$ switching to $-F(B)$ when a reset pulse is given. The chopper cell between the two amplifying stages reverses the polarity according to the set-reset pulses.

A. AMR Sensor Mathematical and SPICE Model

The simplified linear analytical model of the HMC-1001/2 sensor elements in Fig. 2 has been developed to obtain a first order approximation of sensors system frequency response and closed loop stability.

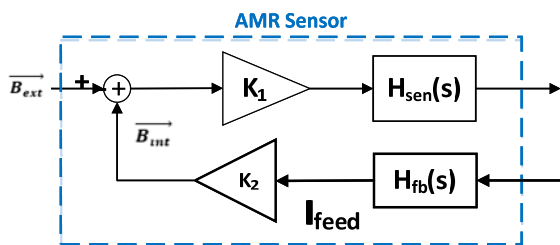

Fig. 2 Simplified analytic HMC-1001/2 sensor diagram

The model includes two paths: 1) The forward one, $H_{sen}(s)$, representing the transfer function of the conversion of the magnetic field intensity to voltage; it captures the

inherent bandwidth of the sensing element using a simplified dominant-pole model, i.e. $H_{sen}(s) = \frac{2\pi f_{sen-3dB}}{s + 2\pi f_{sen-3dB}}$. 2) The feedback path $H_{fb}(s)$ capturing the voltage to magnetic field intensity conversion via the offset coil $H_{fb}(s) = 1/(s \cdot L_{offset} + R_{offset})$. Constants K_1 and K_2 stand for the conversion gain ratios.

The non-linear behavior (at high magnetic field) of the magnetoresistive Wheatstone bridge of both HMC-1001/2 sensor elements was taken into account using the detailed SPICE model in Fig. 3.

With the model in Fig. 3, the behavior of the complete system in terms of frequency response, non-linearity and closed loop stability can be captured. The Voltage-Controlled Voltage Sources (VCVS) E are used as ideal buffers. The VCVS E_{K1} and the Current Controlled Voltage Source (CCVS) H_{K2} are the conversion parameters of the forward and feedback paths respectively as provided by the manufacture of the sensor. The offset strap that creates the offset magnetic field was modeled by the inductor L_{offset} with a resistor R_{offset} in series. In order to create the non-linear behavior of the sensor, a careful selection of the Zener Z_D and the resistor R_Z has been done by simulation and curve fitting. The low pass filter $R_{LP}-C_{LP}$ was used to simulate the bandwidth of the sensor. The DC bias and the output resistance of the sensor were simulated by using the voltage source V_B and the resistor R_{Br} , respectively. Finally, the manufacturer's operating parameters [9] have been taken into account in the linear (Fig. 2) and non-linear (Fig. 3) models.

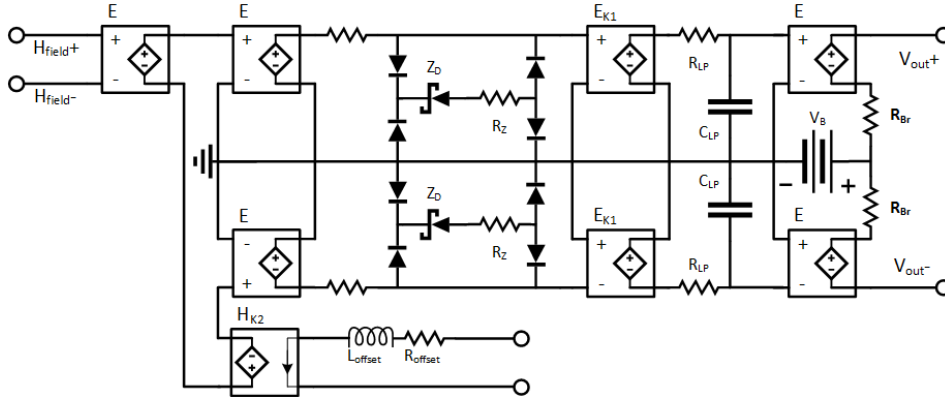

Fig. 3 Spice model for HMC-1001/2

B. System Model of the Closed Loop Architecture

The model of the additional circuitry, implementing the signal conditioning and closed loop operation, was developed. The circuit is divided into two stages: 1) The chopper voltage amplification (LMP2021 chopper opamp); in this stage the sensor's output voltage is amplified, while maintaining the 1/f

noise level as low as possible. 2) High current output voltage amplification (OPA2674 opamp); this stage provides the high output current needed to drive the internal compensation coil L_{offset} of the sensor element and implement the closed loop architecture.

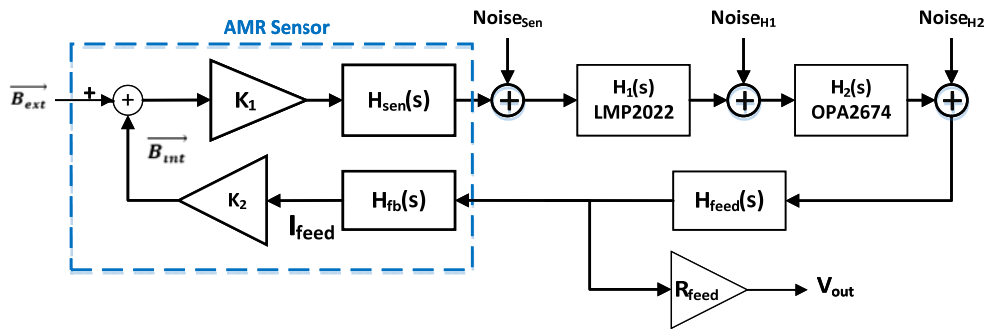

Fig. 4 Simplified analytic system diagram

Fig. 4 shows the complete system model of the sensor element and electronic circuit. The transfer function of the amplifying stages $H_i(s)$, $i = 1, 2$ are given by

$$H_i(s) = \frac{A_i R_{g_i} (s R_{f_i} C_{f_i} + 1)}{(A_i R_{g_i} R_{f_i} C_{f_i})^s + A_i R_{g_i} + R_{f_i}} \quad (1)$$

and the remaining feedback loop behavior is captured by

$$H_{feed}(s) = \frac{R_{feed}}{R_{feed} + R_{par1} + R_{par2} + R_{offset} + s L_{offset}} \quad (2)$$

The output voltage noise power spectral density of $H_1(s)$ and $H_2(s)$ are $E_{H1} = 7,7 \mu V / \sqrt{Hz}$ and $E_{H2} = 69 nV / \sqrt{Hz}$ respectively. Finally, (3) gives the complete transfer function

$$H_T(s) = \frac{K_1 H_{sen} H_1 H_2 H_{feed} R_{feed}}{1 + K_1 K_2 H_{sen} H_1 H_2 H_{feed} H_{fb}} \approx \frac{15697.2 \pi \cdot 5.6K}{s + 2 \pi \cdot 5.6K} \left(\frac{Volt}{Tesla} \right) \quad (3)$$

and the close loop noise is

$$E_{Total} = 28.77 \mu V / \sqrt{Hz} @ 10Hz \quad (4)$$

Considering (4), it should be mentioned that, according to the theoretical analysis of (3), the total close loop noise density referred to the input is $1.9 nT / \sqrt{Hz} @ 10Hz$.

C. Measurement Setup

The experimental setup consists of two different setups which are presented in Fig. 5. DC magnetic field measurements have been conducted in laboratory environment employing a cubic Helmholtz coil setup (Fig. 5 (a)) in order to calibrate/characterize the system under consideration. The effective bandwidth of the system was identified by AC field measurements using the same setup. Finally, the setup used for magnetic noise characterization is displayed in Fig. 5 (b).

In the former case, a high accuracy DC power supply (Yokogawa 7651) has been used for providing the operating current to the Helmholtz coils. On the other hand, a voltage controlled current source driven by a function generator (Agilent 33220A) has been utilized for AC measurements. The results were recorded by a multichannel voltmeter (Keithley 2000) and by an oscilloscope (Agilent MSO9404A).

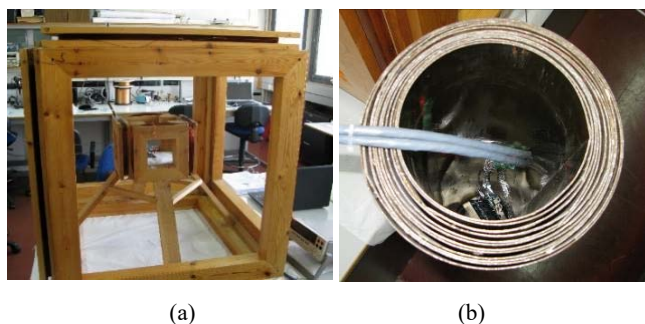

Fig. 5 Experimental setup, (a) cubic Helmholtz Coils (b) Magnetic Shield

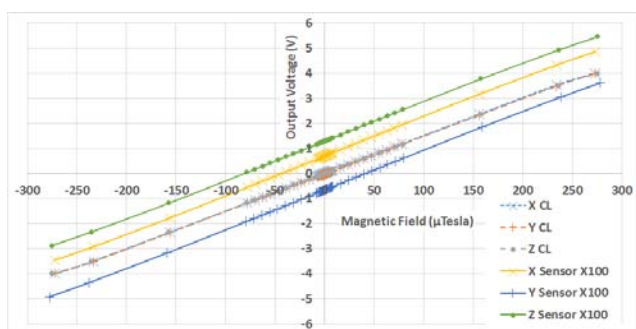

Fig. 6 DC measurements

III. MEASUREMENTS AND DISCUSSION

Every sensor system needs to be calibrated and characterized. This process is presented in the next section. First the “DC Measurements and Calibration” presents the result for the identification of the sensor as well as relationship between the magnetic field and the voltage output. Consequently, it presents the deviation from linearity both for the system and the sensor. The bandwidth of the sensor is presented in the section “Frequency Response”. Finally, the section “Magnetic Noise Characterization” corresponds to the noise level at each frequency. The latter is very important due to the fact that is the main reason which reduces the resolution capability of a sensor.

A. DC Measurements and Calibration

Using a high precision current source and the Helmholtz coils of Fig. 5 (a), a controlled linear magnetic field was generated. Both the proposed closed loop sensor system and the sensor alone were tested in this chamber.

Utilizing the method of the least squares, a first order correlation between the magnetic field and the voltage output of the closed loop system (V_{CL}) as well as the voltage output of the sensor (V_S) was obtained (Fig. 6 and Table I). It can be seen that the closed loop system demonstrates lower diversion in the slope and the constant coefficients than the sensor elements.

To observe the (DC) nonlinearity of the system and the sensor element, the linear components were subtracted from their curves, and the remaining nonlinear components were normalized. The results are shown in Fig 7.

The superiority of the proposed close loop sensor system

can be clearly identified in Fig. 7. The experimental results indicate that this close loop AMR sensor has a maximum deviation of 0.36% with respect to the ideal linear response.

TABLE I
 EQUATIONS CORRELATING THE MEASURED MAGNETIC FIELD AND THE VOLTAGE OUTPUT

Axis	Equation
X	$V_{CLX} = 14,89 \left(\frac{mV}{\mu T}\right) \cdot B + 12,4(mV)$
Y	$V_{CLY} = 14,86 \left(\frac{mV}{\mu T}\right) \cdot B + 10,5(mV)$
Z	$V_{CLZ} = 14,84 \left(\frac{mV}{\mu T}\right) \cdot B + 7,6(mV)$
X	$V_{SX} = 0,155 \left(\frac{mV}{\mu T}\right) \cdot B + 7,04(mV)$
Y	$V_{SY} = 0,156 \left(\frac{mV}{\mu T}\right) \cdot B - 6,5(mV)$
Z	$V_{SZ} = 0,154 \left(\frac{mV}{\mu T}\right) \cdot B + 13(mV)$

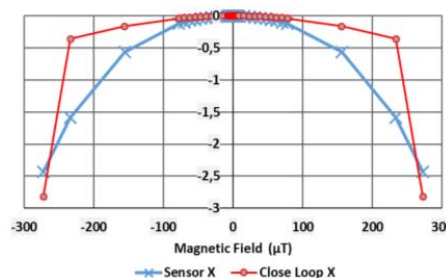

Fig. 7 Nonlinearity of the close loop system and the sensor element

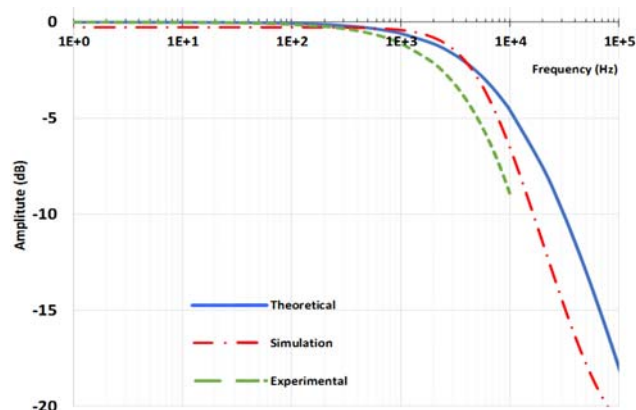

Fig. 8 AC bandwidth measurements

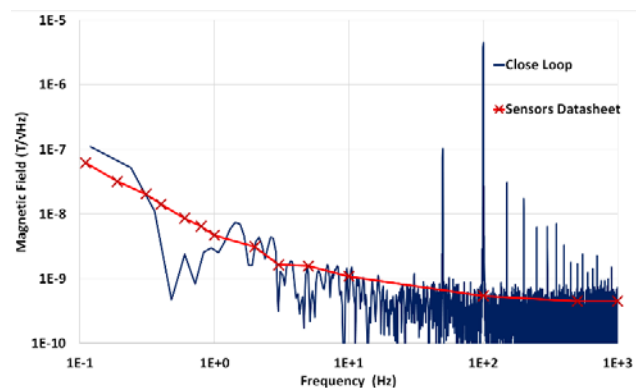

Fig. 9 Magnetic noise measurements

B. Frequency Response

The frequency response was derived by stimulating the Helmholtz coils with AC current. The provided current was generated by a (voltage-output) function generator driving a high precision voltage controlled current source (VCCS). Fig. 8 displays the frequency response of one axis (the response of the other two is similar). The experimental and the theoretical data are in good agreement.

C. Magnetic Noise Characterization

In order to obtain the noise figure, the closed loop system was placed inside the magnetic shield as shown in Fig. 5 (b). The experimental results with respect to the noise of the sensor and the closed loop system, stimulated by a 100-Hz magnetic field, are presented in Fig. 9. The theoretical data extracted through the datasheet of the sensor have also been included for comparison.

IV. CONCLUSION

The experimental and the theoretical results of the closed loop AMR sensor system indicate that the proposed architecture can provide an alternative and cost effective solution for high precision measurements compared to more expensive sensors types like Flux-Gate. The system demonstrated very good linearity, while maintaining the magnetic noise levels as low as possible. Moreover, the effective bandwidth of the close loop system is wider compared to the other closed loop architectures of other AMR sensor systems found in the literature.

REFERENCES

- [1] P. Ripka, *Magnetic Sensors and Magnetometers*. Artech House Publishers, 2001.
- [2] F. Paixao, C. Quini, O. Baffa, J. Miranda, "A novel device with 36 channels for imaging and signal acquisition of the gastrointestinal tract based on AC biosusceptometry", 2010 Annual International Conference of the IEEE Engineering in Medicine and Biology, Buenos Aires, 2010, pp. 6457-6460.
- [3] S. S. Ibanez et al., "A Front-End ASIC for a 3-D Magnetometer for Space Applications by Using Anisotropic Magnetoresistors", *IEEE Transactions on Magnetics*, vol. 51, pp. 1-4, January 2015.
- [4] S. Leittner et al., "Design of the Magnetoresistive Magnetometer for ESA's SOSMAG Project", *IEEE Transactions on Magnetics*, vol. 51, pp. 1-4, January 2015.
- [5] M. Janosek, J. Vyhnanek and P. Ripka, "CW Metal Detector Based on AMR Sensor Array", *Sensors*, 2011 IEEE, Limerick, 2011, pp. 1515-1517.
- [6] J. Chen, L. Yu, C. Zuo, X. Chen, S. Wu, X. Yang, "Compensation Method of Cross-axis Effect for AMR Sensor", *Electrical and Control Engineering (ICECE)*, 2010 International Conference on, Wuhan, 2010, pp. 603-606.
- [7] K. Mohamadabadi, C. Coillot, M. Hillion, "New Compensation Method for Cross-Axis Effect for Three-Axis AMR Sensors", *IEEE Sensors Journal*, vol. 13, no. 4, pp. 1355-1362, April 2013.
- [8] L. Yu et al., "Error Compensation and Implementation of Embedded High-Precision Magnetometer", *Electrical and Control Engineering (ICECE)*, 2010 International Conference on, Wuhan, 2010, pp. 911-914.
- [9] Datasheet 1- and 2-Axis Magnetic Sensors HMC 1001/1002/1021/1022, https://aerospace.honeywell.com/en/-/media/aerospace/files/datasheet/1and2axismagneticsensorshmc1001-1002-1021-1022_ds.pdf, April 2017.

Neoclis, G. Hadjigeorgiou is a PhD candidate at the School of Electrical and Computer Engineering, National Technical University of Athens (NTUA),

Greece. He has had his Master Degree on the subject Automation Systems at the School of Mechanical Engineering, National Technical University of Athens. His Master thesis was "Detection of the position of sea vessel with magnetic techniques." in 2013. He has also had his Bachelor degree at the School of Electrical and Computer Engineering, of the National Technical University of Athens. He has his Bachelor thesis on "Acceleration of the search of the cyclic representation of posets with GPU" in 2011.

Anastasia C. Tsalikidou has also had his Bachelor degree at the School of Electrical and Computer Engineering, of the National Technical University of Athens. He has his Bachelor thesis on "Design and construction of closed-loop circuit for AMR sensor" in 2016.

Evangelos V. Hristoforou, D.Eng, Ph.D, C.Eng, is Professor of Electronic Materials at the School of Electrical and Computer Engineering, National Technical University of Athens (NTUA) and Director of the laboratory of Electronic Sensors. His group is performing research in the following fields-clusters:

- Materials and Applications for Sensors and Transducers (MAST), with the most important product concerning a method and instrument to monitor the 3-d stress tensor distribution in steels
- Hybrid Electric Energy Integrated Cluster (HELENIC), with the most important advances referring to the sustainable and affordable production of hydrogen from water
- Magnetism for Biomedical Applications (MBA), a new-born activity, concerning driving and monitoring of magnetic nanoparticles

He is actively related to several industries in the field of sensors, energy and health, running industrial and research projects. He has published more than 150 papers in international journals (h-index=21) and he gave more than 30 invited talks in international conferences. He is the: Representative of Greece in the Universal Network of Magnetic NDE; Vice-Chair of the Hellenic NDT Association; Chair of the European Magnetic Sensor and Actuator (EMSA) Conference; Chair of the International Conference on Materials and Applications for Sensors and Transducers (IC-MAST); Editor-in-Chief in "Journal of Materials and Applications for Sensors and Transducers"; Regional Editor in "Recent Patents in Material Science"; Editorial Board in "Journal of Electrical Engineering", "Journal of Automation Mobile Robotics and Intelligent Systems" and "Measurement Automation Robotics"

Paul P. Sotiriadis (Senior IEEE member) received the Ph.D. degree in Electrical Engineering and Computer Science from the Massachusetts Institute of Technology, Cambridge USA, in 2002, the M.S. degree in Electrical Engineering from Stanford University, California USA in 1996 and the Diploma degree in Electrical and Computer Engineering from the National Technical University of Athens, Greece in 1994. In 2002, he joined the Johns Hopkins University as Assistant Professor of Electrical and Computer Engineering. In 2012, he joined the faculty of the Electrical and Computer Engineering Department of the National Technical University of Athens, Greece.

He has authored and coauthored more than 95 technical papers in IEEE journals and conferences, holds one patent, has several patents pending, and has contributed chapters to technical books. His research interests include design, optimization, and mathematical modeling of analog and mixed-signal circuits, RF and microwave circuits, advanced frequency synthesis, biomedical instrumentation, and interconnect networks in deep-submicrometer technologies. He has led several projects in these fields funded by U.S. organizations and has collaborations with industry and national labs.

He has received several awards, including a Best Paper Award in the IEEE Int. Symp. on Circuits and Systems 2007, a Best Paper Award in the IEEE Int. Frequency Control Symp. 2012 and the 2012 Guillemin-Cauer Award from the IEEE Circuits and Systems Society. Dr. Sotiriadis is an Associate Editor of the IEEE Trans. on Circuits and Systems – I and the IEEE Sensors Journal, has served as an Associate Editor of the IEEE Trans. on Circuits and Systems – II from 2005 to 2010 and has been a member of technical committees of many conferences. He regularly reviews for many IEEE transactions and conferences and serves on proposal review panels.