

# Fiber-Reinforced Sandwich Structures Based on Selective Laser Sintering: A Technological View

T. Häfele, J. Kaspar, M. Vielhaber, W. Calles, J. Griebisch

**Abstract**—The demand for an increasing diversification of the product spectrum associated with the current huge customization desire and subsequently the decreasing unit quantities of each production lot is gaining more and more importance within a great variety of industrial branches, e.g. automotive industry. Nevertheless, traditional product development and production processes (molding, extrusion) are already reaching their limits or fail to address these trends of a flexible and digitized production in view of a product variability up to lot size one. Thus, upcoming innovative production concepts like the additive manufacturing technology basically create new opportunities with regard to extensive potentials in product development (constructive optimization) and manufacturing (economic individualization), but mostly suffer from insufficient strength regarding structural components. Therefore, this contribution presents an innovative technological and procedural conception of a hybrid additive manufacturing process (fiber-reinforced sandwich structures based on selective laser sintering technology) to overcome these current structural weaknesses, and consequently support the design of complex lightweight components.

**Keywords**—Additive manufacturing, fiber-reinforced plastics, hybrid design, lightweight design.

## I. INTRODUCTION

TODAY, many industrial companies are faced with challenges of assigning new lightweight-oriented concepts into products, which are based on innovative materials (e.g. carbon fiber reinforced plastic (CFRP)) as well as revolutionary technologies (for example, additive manufacturing (AM)) [1]. In this case, with the demand for an increasing diversification of the product spectrum along with the decreasing unit quantities of each production lot, there is a necessity to develop hybrid solutions within a flexible and digitized production (“fourth industrial revolution”).

Concerning these matters, traditional processes are already reaching their limits or fail to address these trends. At the same time, new technologies like the design-driven manufacturing process of AM create new opportunities regarding extensive potentials in product development [2], [3]. However, the structural strength of these tailor-made products is still far too insufficient for industrial purposes. Therefore, depending on the type of process and their level of reinforcement, endless fibers or short fibers are used, which have different load-specific (anisotropic) mechanical

properties.

In order to produce components with complex structures, a technological and procedural conception of a hybrid additive manufacturing process is presented below. It enables to realize parts with optimized sandwich structures by applying selective laser sintering (SLS) combined with (endless) fiber-reinforcements. Thus, this approach meets important requirements such as high-strength, multifunctional design and a maximum of individuality of tailored lightweight solutions. For this purpose, the fundamental development of diverse additive processes and finally current state-of-the-art approaches even with regard to hybrid technologies is considered first (Section II). However, immediately afterwards, the actual hybrid additive process is outlined in detail in a technological view (Section III). In addition, Section IV enters the indispensable part of constructive aspects. At the end, an application example substantiates the relevance and meaning of the production process and shows the far-reaching potentials in future (Sections V and VI).

## II. STATE OF THE ART – ADDITIVE MANUFACTURING

The recently emerging issue of lightweight design, for example the maximizing fulfillment of functionality while simultaneously saving on weight when choosing the right strategy (conceptual and technological) in the right place and at the right time [4], represents one of the most predominant innovation drivers within the industrial product development [1], [5]. This, moreover, leads to one decisive key factor concerning sustainable aspects (particularly in the mobility sector), and extensively benefit from the wide potentials of innovative technological developments [6], [7]. One of these advantageous technologies is the additive manufacturing – a layer-based construction approach allowing material design from 3D digital models. This design-driven process, on the one hand, offers unique design flexibility according to the increasing demand on manufacturable topology-optimized structures (e.g. based on bionic principles), and on the other hand, the feasibility of integrated functionalities [8].

### A. Additive Manufacturing Technologies – An Overview

The Battelle Memorial Institute (Ohio, USA) already pointed out the elementary fundamentals of the additive manufacturing and 3D printing technologies in the late 1960s, where first “real” attempts took place to create solid objects three-dimensionally using photopolymer resin processed by two intersecting laser beams [9]. Then, the principle of a solid “formless” or rather “freeform” manufacturing technology to generate complex and near-net-shaped components is gaining

T. Häfele, J. Griebisch and W. Calles are with the Mechanical Engineering Department, University of Applied Sciences Saarland, Saarbruecken, SL 66117 Germany (phone: +49 (0) 681/5867912; e-mail: tobias.haefele@htwsaar.de).

J. Kaspar and M. Vielhaber are with the Institute of Engineering Design, Saarland University, Saarbruecken, SL 66123 Germany (phone: +49 (0) 681/30271234; e-mail: kaspar@lkt.uni-saarland.de).

an ever-greater significance [10]. Nevertheless, the initial application of this generative technology was limited to the area of fabricating haptic conceptual models or physical prototypes (so-called prototyping) due to their weak mechanical and thermal properties [9], [10].

By the new AM process technologies, the scope could be expanded particularly with regard to the direct manufacturing of smaller, not excessively stressed structural components along with their wide range of materials, as shown in Table I.

TABLE I  
 OVERVIEW OF COMMERCIALY MOST PROVEN AM TECHNOLOGIES [11], [12]

	3DP	SL	FLM	SLS	LBM
plastics	✓	✓	✓	✓	
metals	(✓)		(✓)	(✓)	✓
moulding sands	(✓)			✓	
ceramics	✓	✓		✓	

\* SL = stereo lithography; FLM = fused layer modeling; SLS = selective laser-sintering; LBM = laser beam melting; 3DP = 3D printing

In conclusion, the respective products exhibit several varying characteristics due to the various technological approaches in the manufacture of AM-components. Thus, such process technologies (except 3DP and its use only in case of prototypes in the very first phase of product development – so-called design thinking) need to be evaluated according to their component properties in respect of the following assorted limiting conditions, see Table II.

TABLE II  
 QUALITATIVE EVALUATION AND COMPARISON OF AM TECHNOLOGIES  
 ACCORDING TO ASSORTED LIMITING CONDITIONS [12], [13]

	SL	FLM	SLS	LBM
mechanical properties	••	••	•••	••••
thermal properties	•	••	••	••••
component accuracy	••••	••	•••	•••
surface quality	••••	•	••	••
finishing & cleaning	•••	•••	••	•
long-term stability	•	••	••	••••
processing time	••	•	•••	••
production rate1	••	•	••••	••
intended use2	•	••	•••	••••
total score	20	16	24	26

1 space & economic efficiency; 2 • model making, ..., •••• industrial purpose.

As can be seen above, the LBM-technologies truly offer the best structural characteristics regarding industrial purposes, but in the end, they have to be considered separately owing to their purely metallic intention. This is in particular because the raw materials (e.g. aluminum or titanium alloys) do not only satisfy far too differentiating properties, but also possess higher costs in comparison to non-metallic processes. All in all, subject to these limitations and by means of the examined criteria, the selective laser sintering technology evolves the most promising and economical (synthetic) lightweight potential, given the fact of its adequate mechanical properties, high component accuracy and thirdly its “relatively” fast processing time. Additionally, however, also material-specific features of high integration functionality like one-piece

locking mechanisms can be realized.

To sum up, like other processes, additive manufacturing offers, on the one hand, major unique advantages, e.g.

- material and resource efficiency on the actual part, but also its surrounding (saving of jigs and cutting tools),
- economic and custom-fitting (individually tailored) part and production flexibility (“true” load-specific geometrical freedom in engineering design),
- high integration functionality, but, on the other hand, also serious drawbacks, like
- weak mechanical performance (compared to their traditionally manufactured counterparts or modern composite technologies),
- (if applicable) size limitations along with low-volume production leading to high costs for larger lot sizes, and
- imperfections (on surface).

Consequently, there is an urgent necessity with regard to a hybridization with local or global composite reinforcements concerning highly stressed functional and/or structural parts.

### B. State of the Art – Additive Hybrids

At this time, one of the biggest challenges of additive manufacturing is the application for end-use parts. Besides cost and speed of production, one problem is the perception that AM is only for rapid prototyping and not for direct component manufacturing [14]. In this context, the mechanical properties are an essential factor.

Dependent on the used plastic materials and techniques, the properties range from mechanically useless up to mechanically loadable components. For this reason, additive manufacturing is quite often combined with fiber-based composites, e.g. in FLM and SLS, to improve the mechanical properties of printed parts and meet the corresponding demands [15].

Besides the use of short or long fibers [16], the embedding of continuous fibers into the Fused Layer Modeling Process presents another possibility [17], [18]. Within this process, the reinforcing fibers are oriented along with the corresponding build-up of layers during the printing process. In industrial context, the company MarkForged, Inc. is the only manufacturer of 3D desktop and industrial line printers to embed continuous fibers to create printed composite end-use parts. The need for supporting structures, usual in FDM, limits the complexity of printed parts. Accordingly, the integration of functions like movable elements, or channels, etc. is very difficult.

Another approach is based on the reinforcement of AM-structures with fiber materials like layers and weavings. One of them is represented by the Rapid Shaping Process, which provides the integration of fiber reinforcements at the post processing [19]. In this method, fused deposition modeling is used to produce form cores for the subsequently cladding with FRP, similar to the conventional machining of foam core structures. After completion of the component, the core can be removed (cf. lost foam casting) or can remain as support structure with additional weight. This production of lost form cores can even be realized with extractable materials, e.g. FLM with water-dissolvable material/gypsum (*Stratasys Ltd.*),

3D sand printing (*voxeljet AG*) or 3D lost wax casting (*3D Systems*) [20]. Another one uses a tool dependent reshaping/joining-process, which combines AM- structures with semi-finished fiber reinforced thermoplastic products [21].

Fiber-reinforced plastics are also used with the SLS technology, e.g. “Carbonmide”, a carbon fiber filled polyamide 12 material (distributed by *EOS GmbH*), with excellent stiffness and maximized strength-to-weight ratio. In relation to the boundary conditions of the process, only short fibers can be used. Due to resulting fiber interruption, they do not reach the mechanical properties, e.g. strength of endless fibers.

### III. DEVELOPMENT OF ‘SLS/FRP’-HYBRIDS

In this article, a technological and procedural conception of a hybrid AM process is presented to overcome the described problems of the state of the art approaches.

These hybrid components are based on core structures with optimized geometry, manufactured by SLS, which serve as base for the cladding with fiber-materials. Finally, they get finished by Vacuum Assisted Resin Infusion (VARI) to complete the fiber reinforcement.

TABLE III  
 QUALITATIVE COMPARISON OF SLS, VARI, AND HYBRIDS

	SLS	VARI	Hybrid
mechanical properties	***	****	****
thermal properties	**	**	**
component accuracy	***	**	***
surface quality	**	.	**
finishing & cleaning	**	.	.
long-term stability	**	****	**
production rate <sup>1</sup>	****	.	****
reduced complexity costs	****	.	**
lightweight potential	**	****	****
component distortion	**	****	**
<b>total score</b>	<b>27</b>	<b>24</b>	<b>29</b>

<sup>1</sup> space & economic efficiency (even with small lot sizes as low as one (1) and with more variants)

The objective of this approach is the production of SLS/FRP-hybrid components with complex structures, regarding high-strength, multifunctionality as well as material efficiency. In this context, the process-typical anisotropic properties, e.g. tensile strength or surface quality, have to be considered in the design process. Exemplarily, it is influenced by the build-up direction of AM-parts or the fiber directions of FRP. Due to the synergies between both processes, a material structure with higher qualities than the respective single ones can be developed, as shown in Table III. Further, the load paths within the parts can be adjusted to the specific loading conditions of each part in sense of lightweight design construction. In doing so, drawbacks of both processes are most widely eliminated. Examples are the fabrication of complex three-dimensional forming tools for VARI, or the insufficient mechanical properties of SLS-parts. Thus, the structural-mechanical strength is guaranteed by both materials:

the local application of endless fibers for the outer shell and the internal load paths in the polyamide core. Within the (topology) optimized core, tensions can be transferred straight into the fiber reinforcements. As a result, the stress distribution and distortion are more homogeneous and have lower maximum values. Thus, tensile forces should be absorbed by fiber reinforcements, forces vertical to fibers by the core structure support. Additionally, the optimized shape of the core supports the matrix of the FRP when being loaded transverse to the fiber orientation. Due to the reduced tensions in the fiber/matrix interface, the low damage tolerance of fiber-reinforced structures perpendicular to the fiber direction can be increased. Thus, the energy absorption in structures which are relevant for the crash behavior is supported by the SLS-core, which finally increases the damage tolerance in total.

In summary, compared to state-of-the-art processes, the SLS sandwich core elements do not only determine the shape, but rather meet the load path requirements. Additionally, they allow the integration of attachment points and functions, without the need for supporting structures, e.g. movable elements and flow channels. Instead of conventional use as pure shaping tool, the AM-part serves as a multifunctional part with important tasks. Compared to state of the approaches, like provided from *MarkForged, Inc.*, there are less restrictions of the design process itself. Further, the new process has the possibility to apply continuous fibers instead of just short or partly longer fibers.

The materials used are PA2200, based on polyamide 12 and carbon fibers (rovings, layers, weavings) as well as thermosetting/thermoplastic matrix systems. In this context, various samples have been produced in different compositions and orientations. To proof the interlaminar connection and the mechanical strength of the material combination, the samples were analyzed by destructive testing (tensile, shear and bending).

In spite of the wide range of thermosetting resins and the appropriate fiber types, the thermoplastic matrix has an improved connection and processing characteristic. For example, the cycle time of VARI can be reduced from 24h (thermosetting resin) to 45 min (thermoplastic resin). In addition, the thermoplastic matrix can be reshaped under the influence of heat and allows the recycling of SLS/FRP-Hybrids.

In the end, the new method has been successfully applied on a first application example, in terms of a rotor blade for a vertical axis wind turbine. A more detailed view is presented in section “design guidelines”.

### IV. DESIGN GUIDELINES

Nevertheless, apart from the optimized production process with its wide range of adjustable parameters, the fundamental product development procedure and the right design aspects have to be considered with regard to the appropriate conception and construction of the individual parts. Indeed, standardized and internationally well-known product development methodologies, such as those of ULLMANN,

PAHL/BEITZ and ULRICH/EPPINGER, fail to address this new level of freedom, particularly concerning the integrated consideration of product design as well as material and technology selection of hybrid approaches. Thus, the authors have already presented an integrated and cross-component hybrid additive and lightweight engineering (HALE) product development process to deal with this specific Design for Manufacturing and Assembly (DfMA) issue, and finally to overcome the common

- exclusive design on functional and constructive aspects, instead of a stronger integration of the respective production processes and the appropriate material selection (for example mostly material and process-independent evaluation and selection of solution principles and their combination, instead of an integrated assessment),
- extensive neglect of modern computational tools (for example topology and shape optimization), often analogous to the field of lightweight development methodologies, and
- predominant division into modules, but neglecting the joint section definition and design [22].

Without going too much into detail, below is a short description of the partly iterative process with the aid of a

schematic example consisting of two subsystems and its three components in connection with their different adjacent joint sections, see Fig. 1.

Obviously, after an initial clarification of the requirements and boundary conditions as well as a general function analysis on system and subsequently on subsystem level, a preliminary topology determination of the additive core element takes place, and a technology definition and material property profile is stated at the same time. As a result, the definition and fundamental shape of the joint sections is realized. In the following, the detailing process continues. This means that local and/or global reinforcements have to be indicated on the right place on each component part in accordance with the individual load paths based on CA(I)O. In doing so, also the joint sections must be taken into account in particular for the small additive building spaces. In case of the current huge amount of systematic FRP specifications [23] placed at the constructor's disposal, a detailed analysis is pivotal for lightweighting. Therefore, the follow-up paragraph also displays an extract of the 12-page "SLS/FRP"-hybrid design guideline catalogue, which includes general, SLS- and FRP-specific design aspects and rules on a visual way (i.e. unfavorable and favorable examples with explanation), see Fig. 2.

Open Science Index, Materials and Metallurgical Engineering Vol:11, No:7, 2017 publications.waset.org/10007502.pdf

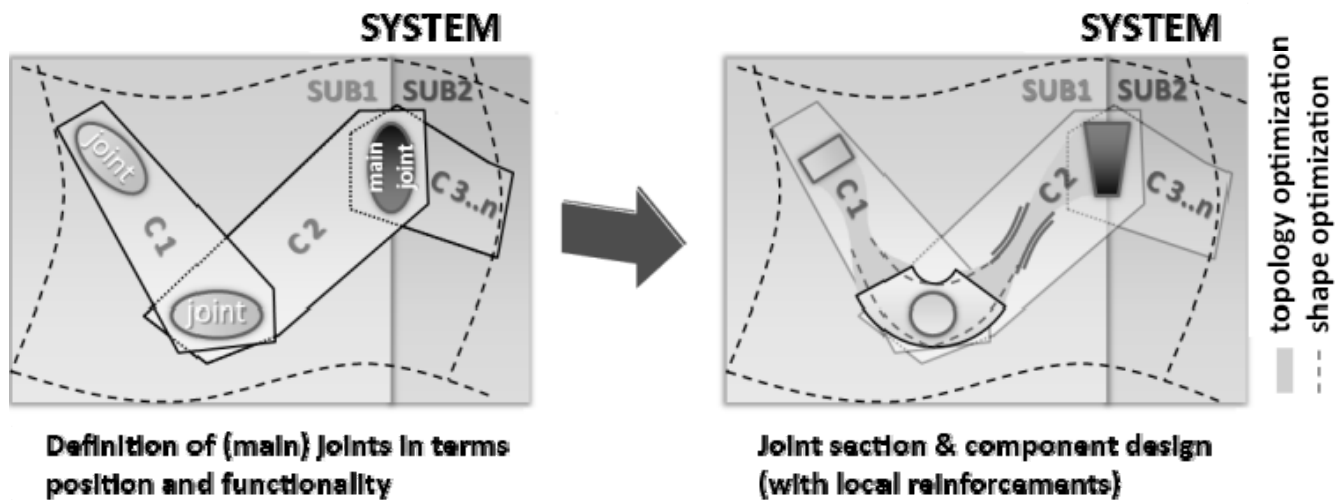


Fig. 1 Schematic example of the HALE development process [22]

Herein, the functional capability and basic geometrical design (for example symmetrical build, local reinforcements) is handled in the same way as the aspects of designing edges, transitions and joints. SLS-specifically, also the issues of specific elements (springs, screw threads and fluid channels) are focused.

All in all, to fulfil the systematic support of the design engineer's tasks of this novel technology process, a good basis has been taken.

#### V. APPLICATION EXAMPLE

In close collaboration with the lab for wind energy of the University of Applied Sciences in Saarland, an application

example results from the development of a small vertical axis wind energy plant (Fig. 3).

The investigation includes possibilities for integrating load paths to optimize the material usage of FRP and PA in a synergetic interaction. Therefore, the rotor blade design was developed for a site-specific wind speed and wind direction measured over a one-year period.

Due to the limited space of the SLS-machine, the blades were printed in five sections and bonded afterwards. Fig. 3 (a) shows one of the sections. Based on a finite element analysis, carbon fiber reinforcements were used to get a higher stability on the hot spots as well as an overall homogeneous stress distribution (Fig. 4).


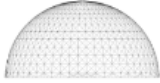
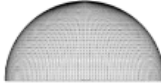
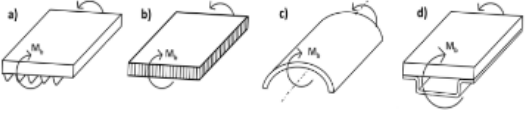
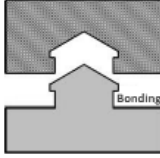
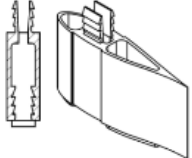
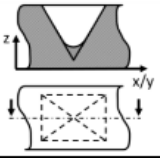
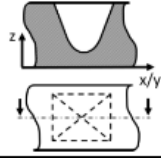
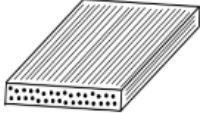
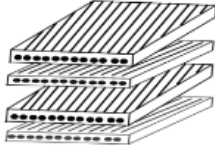
ingenieurwissenschaften htw saar		Design guidelines - manufacturing-specific construction -			
<b>Fiber-Reinforced Plastics (FRP) &amp; Selective Laser-Sintering (SLS)</b>					
Classifica-tion		Explanation / Design rule		Visualization / Example	
1.1	Functional capability	<u>STL resolution:</u> As high as possible, but as low as necessary (especially for curved outlines)		unfavourable 	favourable 
2.3	Geometrical design	<u>Planar loading:</u> Plates should be designed not homogeneously solid (local stringers (a), sandwich structures (b), precamber of structure (c), or a bivalve design (d))		favourable 	
4.7	Joints	<u>Form-force-fit with additional bonding:</u> Form-force-fits shall be equipped with pre-centering in order to equalize inadequate alignment		unfavourable 	favourable 
<b>SLS - specific</b>					
Classifica-tion		Explanation / Design Rule		Visualization / Example	
8.1	Corners	<u>Inside-facing edges:</u> Residual powder in corners and edges (e.g. due to support geometry) must be easily removable  (Keep in mind laser focal diameter)		unfavourable 	favourable 
<b>CFK - specific</b>					
Classifica-tion		Declaration / Design rule		Visualization / exemplification	
13.1	Wall thickness	<u>Layer thickness:</u> <ul style="list-style-type: none"> <li>• Single Layer should not be too thick</li> <li>• <b>preferable:</b> several thin layers which alternate by +/- 5% around central symmetry                      (Reason: fatigue resistance goes up due to the alternation)</li> </ul>		unfavorable 	favourable 

Fig. 2 Extract of the “SLS/FRP”-hybrids design guideline catalogue

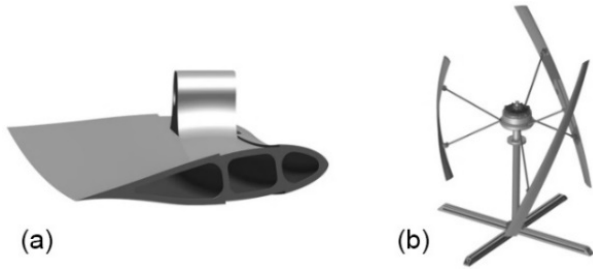


Fig. 3 Rotor blade (a) for application of vertical axis wind turbine (b)

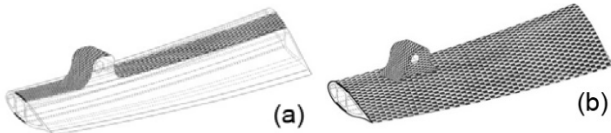


Fig. 4 Selective reinforcement of load paths (a) and top layer (b)

TABLE IV  
 COMPARISON: ADDITIVE-MANUFACTURED ROTOR BLADE AND HYBRID ROTOR BLADE

Approach	AM - SLS	Hybrid – SLS/FRP	Gain factor
Deflection	3 mm	0.69 mm	0.23
	6 mm	1.21 mm	0.20
Weight	94 g	113 g	1.2

Exemplarily, as shown in Fig. 4 (a), a rotor blade module has been reinforced with carbon fibers to compare the bending strength of SLS and SLS/FRP-hybrid parts. Thus, the reinforcement increases the bending strength up to 500%, with an increasing weight of only 20%, as shown in Table IV.

Compared to traditional manufacturing, the new process allows the unique flow optimization of shell geometries out of appropriate fluid simulation data, to create tailor made rotor blades. Usually, the conventional process includes the creation of tools for basic-/negative forms and the joining (step 1/2/5), as well as the multiple post processing (for example trimming)

and the VARI-process (step 3/4/6/7). Depending on tooling, the process provokes increased costs, notably in small lot sizes and/or a higher complexity. The new approach, however, replaces step 1-4, offering the possibility of tailor made parts and reducing the number of process steps from 7 to 4 (Table V and Fig. 5). Thus, the CFRP can be saved, that is usually required for a basic stability (for example joining), but is not necessarily used to resist strong forces. Furthermore, the AM-core-element can be used to integrate a function, like attachment points (Fig. 4), joints, hinges, as well as fixtures for cables and sensors. An example is represented in Fig. 6, which shows an integrated quick-locking mechanism, for an improved joining-process of the five separate rotor components. The outcome of this new approach is a rotor blade, which is geometrically optimized for local wind conditions and respective attachment points. Moreover, in combination with the new manufacturing process, the material efficiency of CFRP is improved as already described in Fig. 4. At this stage, the example shown has just a core-structure with a small level of complexity. In future, the investigations will be extended with parametric-steered internal structures (for example grid structures - Fig. 7), to proof further design elements under consideration of appropriate design guidelines.

TABLE V  
 CONVENTIONAL VS. HYBRID ADDITIVE MANUFACTURED ROTOR BLADE

	Conventional	Hybrid – AM/FRP
1	opt. Basic form	
2	negative form	AM-core (finished)
3	fiber application + VARI	
4	post-Processing	
5	adhesive bonding	opt. adhesive bonding
6	fiber application + VARI	fiber application + VARI
7	post-processing	post-processing

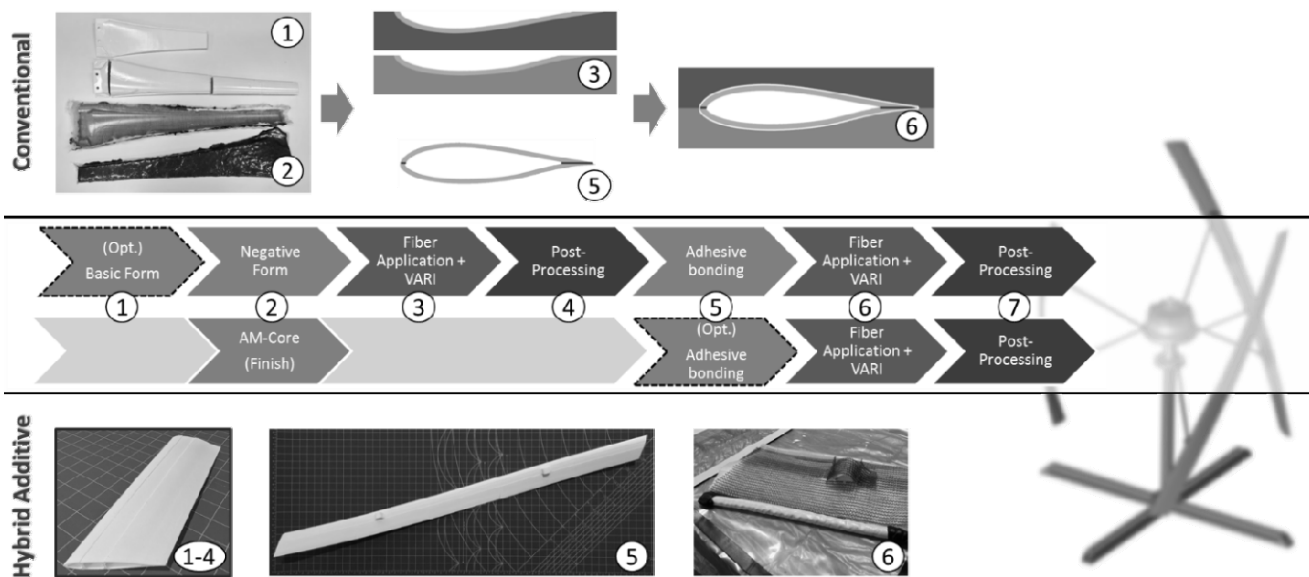


Fig. 5 Conventional vs. hybrid additive manufactured rotor blade

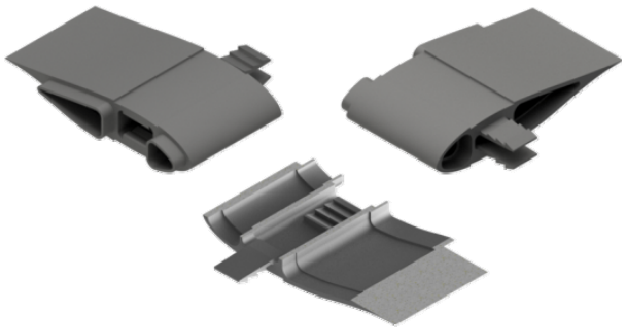


Fig. 6 Integrated locking mechanism

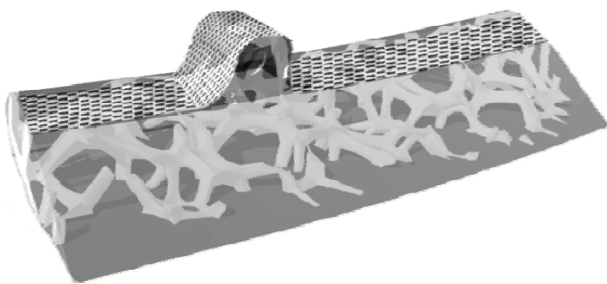


Fig. 7 Core structure with "inner grid structure" (outlook)

## VI. CONCLUSION

Based on state-of-the-art approaches in terms of additive hybrids, this contribution presents a technological and procedural conception of a hybrid production. In accordance to this approach, the existing design guidelines and development methodologies of AM and VARI have to be considered and adapted to one another, like described in Section IV. Thus, the hybrid-approach can be used to produce parts with high strength and individually customized structures with a higher material efficiency than the respective single approaches. Moreover, drawbacks of both are nearly eliminated, while simultaneously reducing the process steps. Due to the possibility to produce geometrically complex structures, future studies will investigate the application of load specific (bionic) core-structures as shown in Section V. Exemplarily, further applications are intended in the field of medicine (for example prostheses). According to the requirements of patients, like form, loads or connection points, individually tailor-made prosthesis could be conceptualized and produced. Based on these results, the development of the necessary design guidelines and methodological approaches for a successful application of SLS/FRP-hybrids will be continued.

## ACKNOWLEDGMENT

The authors thank the Saarland's federal state project 'Rapid-Prototyping-basierte CFK-Bauteile' (No WT/2-LFFP15/13) for supporting their AM research and the enhanced cooperation between both universities.

## REFERENCES

[1] R. Heuss, N. Müller, W. van Sintern, A. Starke, and A. Tschiesner,

"Lightweight, heavy impact", in *Advanced Industries*, McKinsey & Company, 2012.

[2] S. H. Huang, P. Liu, A. Mokasdar, and L. Hou, "Additive manufacturing and its societal impact: a literature review", *Int. J. Adv. Manuf. Technol.*, vol. 67, pp. 1191–1203, 2013.

[3] Y. Huang, M.C. Leu, J. Mazumder, and A. Donmez, "Additive Manufacturing: Current State, Future Potential, Gaps and Needs, and Recommendations", *J. Manuf. Sci. Eng.*, vol 137, no. 1, pp. 014001–014010, 2015.

[4] J. Kaspar, and M. Vielhaber, "Cross-Component Systematic Approach for Lightweight and Material-Oriented Design", *Proceedings of Nord Design*, vol. DS 81, no. 1, pp. 332–341, 2016.

[5] Federal Ministry for Economic Affairs and Energy (BMWi), "Bestandsaufnahme Leichtbau in Deutschland", in *Project I C4-10/15*. Berlin: VDI Zentrum Ressourceneffizienz, 2015.

[6] M. A. Carruth, J. M. Allwood, and R. L. Milford, "Reducing CO<sub>2</sub> Emissions through Lightweight Design and Manufacturing", *AIP Conf. Proc.*, pp. 1632–1637, 2011.

[7] P. K. Mallick, "Materials, design, and manufacturing for lightweight vehicles". Cambridge: Woodhead Publishing Limited, 2010.

[8] T. Campbell, C. Williams, O. Ivanova, and B. Garrett, "Could 3D Printing Change the World? Technologies, Potential, and Implications of Additive Manufacturing", Washington (DC): Atlantic Council - Strategic Foresight Report, Oct. 2011.

[9] Wohlers Associates, Inc., "History of Additive Manufacturing", *Wohlers Report*, 2014.

[10] J. Gausemeier, N. Echterhoff, M. Kokoschka, and M. Wall, "Thinking ahead the Future of Additive Manufacturing – Analysis of Promising Industries", University of Paderborn, 2011.

[11] Verein Deutscher Ingenieure, *VDI-Guideline 3405: Additive manufacturing processes: Basics, definitions, processes*. Düsseldorf: VDI-Verlag, 2014.

[12] I. Gibson, D.W. Rosen, and B. Stucker, "Additive Manufacturing Technologies: Rapid Prototyping to Direct Digital Manufacturing", New York, Springer, 2010.

[13] M. Schmid, „Selektives Lasersintern (SLS) mit Kunststoffen: Technologie, Prozess und Werkstoffe“, München: Hanser Verlag, 2015.

[14] S. Ford, M. Despeisse, "Additive manufacturing and sustainability: an exploratory study", *Journal of Cleaner Production*, pp. 3-4, 2016.

[15] S. Kuma, and J-P Kruth, "Composites by rapid prototyping technology", in *Materials and Design*, vol. 31, pp. 850–856, 2010.

[16] W. Zhong et al., "Short fiber reinforced composites for fused deposition modeling", *Mater. Sci. Eng.*, vol. 301, pp. 125–130, 2001.

[17] R. Matsuzaki et al., "Three-dimensional printing of continuous-fiber composites by in-nozzle impregnation", *Scientific Reports*, 6(23058) 2016.

[18] N. Li, Y. Li, and S. Liu, "Rapid prototyping of continuous carbon fiber reinforced poly(lactic acid) composites by 3D printing", *J. Mater. Process Technol.*, vol. 238, pp. 218–225, 2016.

[19] R. Hornfeck, „Rapid Shaping Prozess zur Herstellung von CFK-Bauteilen“, *Schriftenreihe 52: Georg-Ohm-Hochschule Nürnberg*, 2013.

[20] S.S. Gill, and M. Kaplas, "Comparative Study of 3D Printing Technologies for Rapid Casting of Aluminium Alloy", *Mater. Manuf. Process*, vol. 24, no. 12, pp. 1405–1411, 2009.

[21] Fraunhofer Institute for Production Technology IPT, "3D meets FRP: More flexibility for highly stressed components", Press release / 7.3.2016

[22] J. Kaspar, T. Häfele, C. Kaldenhoff, J. Griebisch, and M. Vielhaber, "Hybrid Additive Design of FRP Components – Fiber-Reinforced Sandwich Structures Based on Selective Laser Sintering Technology", *Procedia CIRP*, vol. 60, pp. 235–240, 2017.

[23] J. Kaspar, and M. Vielhaber, "Fiber-Reinforced Composite Design Within a LMOD process", accepted at 21th ICED, Vancouver: 21.-25.08.2017.