

Optimum Design of Alkali Activated Slag Concretes for Low Chloride Ion Permeability and Water Absorption Capacity

Müzeyyen Balçikanli, Erdoğan Özbay, Hakan Tacettin Türker, Okan Karahan, Cengiz Duran Atış

Abstract—In this research, effect of curing time (TC), curing temperature (CT), sodium concentration (SC) and silicate modules (SM) on the compressive strength, chloride ion permeability, and water absorption capacity of alkali activated slag (AAS) concretes were investigated. For maximization of compressive strength while for minimization of chloride ion permeability and water absorption capacity of AAS concretes, best possible combination of CT, CTime, SC and SM were determined. An experimental program was conducted by using the central composite design method. Alkali solution-slag ratio was kept constant at 0.53 in all mixture. The effects of the independent parameters were characterized and analyzed by using statistically significant quadratic regression models on the measured properties (dependent parameters). The proposed regression models are valid for AAS concretes with the SC from 0.1% to 7.5%, SM from 0.4 to 3.2, CT from 20 °C to 94 °C and TC from 1.2 hours to 25 hours. The results of test and analysis indicate that the most effective parameter for the compressive strength, chloride ion permeability and water absorption capacity is the sodium concentration.

Keywords—Alkali activation, slag, rapid chloride permeability, water absorption capacity.

I. INTRODUCTION

THE concrete industry faces challenges to meet the growing demand of Portland cement due to limited reserves of limestone, slow manufacturing growth and increasing carbon taxes, however, the demand for cement has been constantly increasing due to increased infra-structural activities of the country [1]. One effort to combat the shortfall is the development of alternate binders to Portland cement aiming at to reduce the environmental impact of construction, use of greater proportion of waste pozzolan, and also to improve concrete performance. Search for several alternatives such as alkali-activated cement, calcium sulpho aluminate cement, magnesium oxy carbonate cement (carbon negative cement), super sulphated cement etc. are being made with the advantages of Portland cement [2]. Current research is related with the Alkali activated materials (AAM) which are produced by activating the pozzolanic materials with chemical alkali activators such as alkali hydroxide and/or alkali silicates. It is a potential environmental friendly material for constructions [3]. Research on AAM [4] has provided basic information

about the mechanism of alkali-activation. Mehta [5] reported that coatings of aluminosilicate form on the surface of slag grains within a few minutes of exposure to water, and these coatings were impermeable to water. Within the use of alkali activators, the rate of hydration became faster at high alkali concentrations. Compared to Portland cement-activated slag, alkali activated slag (AAS) has some advantageous properties including rapid development of high strength, good durability and high resistance to chemical attack [6]-[8]. Despite the high mechanical properties of the binder produced by the activation of slag with water glass, the most important disadvantages and technical deficiencies limiting the use of this binder are its higher drying shrinkage potential and higher permeability properties compared to those of Portland cement based binders [9]. The permeability of AAM plays a critical role in controlling the properties of geopolymer, and the serviceability of it. Besides the permeability and general stability, the ability of cracks to conduct gases and water is of significant importance for structures subjected to water and/or vapor pressure (i.e. basements, water retaining structures, water reservoirs, waste containers and confining enclosures of nuclear power plants) [10]. As is well known, the existence of chloride ions and their permeability are the paramount issue for controlling the long term service life of reinforced concretes. However, as mentioned earlier, alkali activated slag concretes (AASC) exhibit considerable drying shrinkage and micro-cracks [11]. Experimental results suggest that permeability increases proportionally to the cube of the crack opening displacement. The relationship between load-induced cracking and concrete permeability is studied by Picandet *et al.* [10]. In that study, ordinary concrete and high-performance concrete, including steel fiber-reinforced concrete are used. Two discs, 50 mm-thick slices, cut from 110–220 mm cylindrical specimens are diametrically loaded, as for a normal splitting test. The lateral displacement, also called the crack opening displacement (COD) is monitored for each loading cycle. After unloading, gas and finally water permeability tests are both performed, using constant head permeameter, to compare the influence of the percolating fluid and the COD. Due to the wide range of measured gas flow, Klinkenberg's and Dupuit-Forcheimer's laws are applied to compute the intrinsic gas permeability. Results suggested that permeability increases proportionally to the cube of the COD and it matches water permeability, if only the first water percolating time is considered. Therefore, the knowledge of chloride ion permeability properties of AASC is fundamental for predicting

M.B, E.O, and H.T.T are with the Iskenderun Technical University, 31200, Iskenderun, Turkey (e-mail: muzeyyen.balcikanli@iste.edu.tr, erdogan.ozbay@iste.edu.tr, hakanturker@iste.edu.tr).

O.K and C.D.A are with the Erciyes University, Kayseri, Turkey (e-mail: okarahan@erciyes.edu.tr, cdatis@erciyes.edu.tr)

its long term performance. Therefore, the foremost purpose of the present research is determining the chloride ion permeability and water absorption capacity of AASC. To achieve this aim, an experimental program was conducted based on the central composite design by considering the curing temperature (CT), curing time (TC), sodium concentration (SC) and silicate modulus (SM) as independent parameters. After performing the tests and getting the results, the effects of each individual parameter and their interactions were qualified and statistically examined. Finally, for the desired compressive strength, chloride ion and water absorption capacity, the best possible value of the independent parameters under the constraints of the current study was identified.

II. EXPERIMENTAL WORKS

In this study, central composite design (CCD) method is used. Totally, 21 mix compositions were constructed. Four independent parameters that might have significant effect on the alkali activated slag concretes were selected to develop the regression models for dependent properties with CCD. The proposed regression models are valid for alkali activated slag concretes with the SC from 0.1% to 7.5%, SM from 0.4 to 3.2, CT from 20 °C to 94 °C and TC from 1.2 hours to 25 hours. In the AASC production, the Turkish ground granulated blast-furnace slag (GGBFS) that is obtained from Iskenderun Iron-Steel Factory was used. Its Blaine is 540 m²/kg. Particle size distribution of the GGBFS used in presented in Fig. 1.

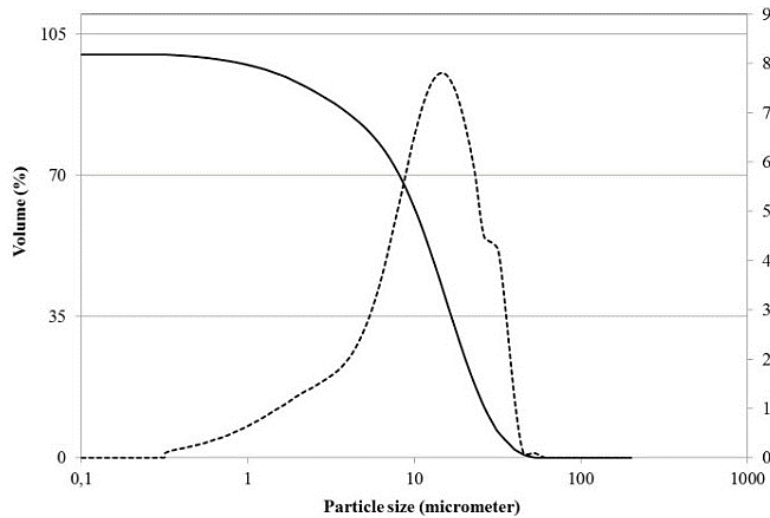

Fig. 1 Particle size distribution of ground granulated blast furnace slag used

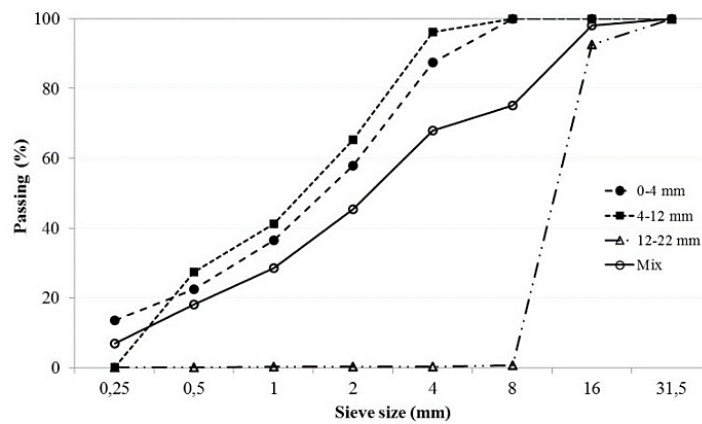

Fig. 2 Grading curve of aggregate used

The sodium silicate (Na₂SiO₃) with a 35.61% solids content (thus containing 64.39% water) and modulus (SiO₂/Na₂O) by weight is 3.2. The alkali solution to GGBFS ratio was held constant at 0.53 in all AASC production. Afterward the mixing of GGBFS and activator solution, crushed limestone aggregate, which is the mixture of 0-4 mm fine aggregate and 4-12 mm and 12-22 mm coarse aggregate was incorporated to the mix and mixed again, and the necessary amount of water

supplemented to predefined alkali solution-GGBFS ratio. The granulometry curves of the aggregates used are illustrated in Fig. 2. After defining the statistically significant independent parameters on the test results, the statistically significant regression model which has the highest correlation coefficient was accepted as the regression model of that dependent variable.

III. RESULTS AND DISCUSSIONS

A. Compressive Strength

The overall compressive strength of AASC was in the range of 3.3 MPa to 58.4 MPa, as pointed out in Table I.

TABLE I
COMPRESSIVE STRENGTH OF AAS AND PC MORTARS

Mixture	Mixture name	Compressive strength (MPa)
M1	26D13S3.8K1.8M	29.8
M2	40D20S6K2.6M	58.4
M3	40D6S1.6K1M	8.2
M4	40D20S1.6K2.6M	3.3
M5	40D6S6K1M	33.9
M6	60D13S3.8K0.45M	36.7
M7	60D13S3.8K1.8M	50.2
M8	60D13S3.8K1.8M	48.8
M9	60D13S3.8K1.8M	50.5
M10	60D13S3.8K1.8M	48.8
M11	60D13S3.8K1.8M	49.9
M12	60D25S3.8K1.8M	44.2
M13	60D13S3.8K3.15M	45.0
M14	60D13S7.5K1.8M	47.2
M15	60D13S0.1K1.8M	-
M16	60D1.23S3.8K1.8M	33.7
M17	80D20S1.6K1M	10.6
M18	80D6S1.6K2.6M	3.5
M19	80D6S6K2.6M	36.2
M20	80D20S6K1M	32.7
M21	94D13S3.8K1.8M	33.7
M22	PC	50.3

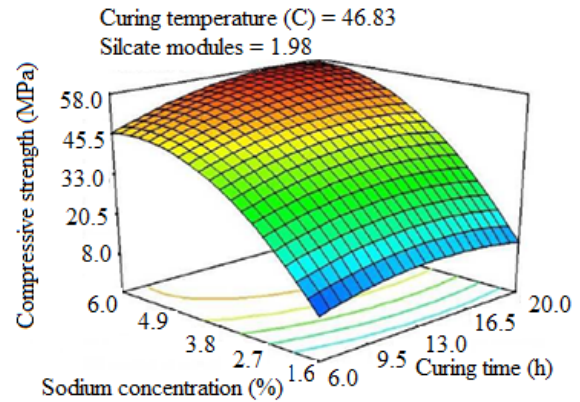

Fig. 3 Effect of SC on compressive strength

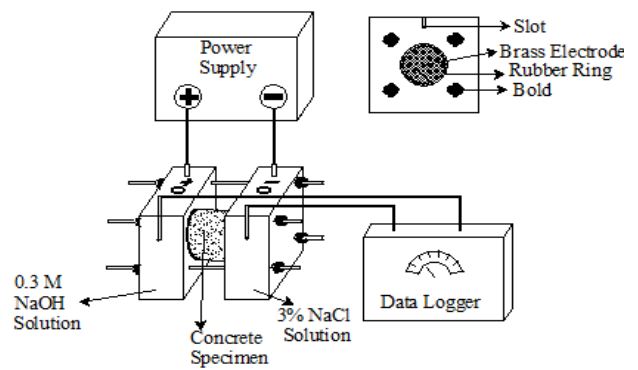

Fig. 4 Rapid chloride permeability test setup

All studied independent parameters have a significant effect on the compressive strength of AAS concretes, however, the most influential independent parameter on compressive strength of AAS concrete is sodium concentration (SC) with 48.9%, and followed by square of SC (SC²) with 21.9% and square of the curing temperature (CT²) with 11.6%. Fig. 3 presents the variation of compressive strength of AASC depend on the combine effect of SC and CTime. As seen in Fig. 3, increase of SC drastically increased the compressive strength, however, effect of CTime is ambiguous.

B. Chloride Ion Permeability

AAS and PC mortar specimens are tested for chloride ion permeability by using the setup shown in Fig. 4. With respect to the experimental results and ANOVA, the most effective independent parameter on chloride ion permeability is SC, as in compressive strength, with 61.8%. Increasing the SC of the AASC mixture, the compressive strength is increased, however, chloride ion permeability remarkably decreased from 11,000 to 4,500 Coulombs at fixed value of CT, TC and SM of 46.8 °C, 8.3 hour and 2.0, respectively. This is partially related with the higher pore solution conductivity of sodium silicate which affected by high Na⁺ and OH⁻ concentrations.

C. Water Absorption Capacity

Water absorption capacity of AASC was in the range 3.2% to 7.62%. It was determined experimentally and from ANOVA analysis, increasing the SC caused to gradual decrease in water absorption capacity. Simultaneously, increasing the TC, water absorption capacity was also increased with a smooth slope. The most effective parameter is SC as in other dependent parameters, with 58.2%. The regression models and optimum production parameters are pointed out in Table II and Table III, respectively.

TABLE II
REGRESSION MODELS OF EXPERIMENTAL DATA

Models	Compressive Strength	RCPT	Water Absorption
Constant	-95.95	+19627.1	+8.21
CT	2.32	-253.89	-0.1605
TC	1.072	+341.34	+4501
SC	23.36	-3759.24	-1.16674
SM	3.43	+2533.31	+1.94174
CT-TC	0	0	-2.472E-03
CT-SC	-0.06	+10.43	-2.130E-03
CT-SM	0	0	+9.77E-03
TC-SC	0.12	0	-0.0229
TC-SM	0.59	-188.28	-0.124
SC-SM	3.07	0	-0.175
CT ²	-0.01	0	+1.424E-03
TC ²	-0.08	+1.504	+1.848E-03
SC ²	-2.45	+276.96	+0.159
SM ²	-5.50	0	-0.148

TABLE III
 OPTIMUM PARAMETERS FOR PRODUCTION AASC AND EXPERIMENTAL
 VERIFICATION RESULTS

Independent and dependent parameters	Optimum values and expected responses	Experimental results for optimum conditions
CT (°C)	75	75
TC (hour)	21.5	21.5
SC (%)	5.89	5.89
SM	3	3
Compressive Strength (MPa)	60	58.8
RCPT (Coulomb)	3934	4210
Water Absorption Capacity (%)	1	1.12

IV. CONCLUSIONS

The influence of curing temperature, curing time, sodium concentration and silicate modules on the compressive strength, chloride ion permeability and water absorption capacity of alkali activated slag concretes was researched by means of design of experiments. The effects of independent parameters were analyzed using variance analysis and statistically significant quadratic regression models were determined. Results showed that all studied independent parameters have significant effect on the compressive strength, chloride ion permeability and water absorption capacity of AASC, however, the most influential parameter for these properties is sodium concentration (SC) with 48.9%, 61.8% and 58.2%, respectively. Increasing the SC of AASC mixture chloride ion permeability remarkably decreased from 11,000 to 4,500 Coulombs at fixed value of CT, TC and SM. Increasing the SC caused the gradual decrease in water absorption capacity.

ACKNOWLEDGEMENTS

Turkish Scientific and Technical Research Council (TUBITAK) supported this research (MAG-214M035). The authors would like to thank TUBITAK for its financial assistance in this research.

REFERENCES

- [1] B. Singh, Ishwarya G., M. Gupta, S.K. Bhattacharyya, Geopolymer concrete: A review of some recent developments, *Construction and Building Materials* 85 (2015) 78–90.
- [2] Shi C, Fernandez-Jiminez A, Palomo A. New cements for the 21st century: the pursuits of an alternative to Portland cement. *Cem Concr Res* 2002; 32: 865–79.
- [3] Guerrieri M. and Sanjayan JG., (2010) “Behavior of combined fly ash/slag-based geopolymers when exposed to high temperatures” *Fire and Materials*, vol. 3, pp.163–75.
- [4] S. Song, D. Sohn, HM. Jennings, TO. Mason, Hydration of alkali-activated ground granulated blast furnace slag, *JOURNAL OF Materials Science* 35 (2000) 249– 257.
- [5] P. K. Mehta, in *Proceedings of the 3rd International Conference on Fly Ash, Silica Fume, and Natural Pozzolans in Concrete*, Trondheim, Norway, 1989, pp. 1–43.
- [6] B. Talling and J. Brandstetr, in *Proceedings of the 3rd International Conference on Fly Ash, Silica Fume, and Natural Pozzolans in Concrete*, Trondheim, Norway, 1989, p. 1519.
- [7] S. D. Wang, *Mag. Concr. Res.* 43 (1991) 29.
- [8] V. D. Glukhovskiy, GS. Rostovskaya and GV. Rummyay, in *Proceedings of 7th International Congress on the Chemistry of Cement*, Paris, 1986, Vol. III, V164–V168.
- [9] S. Aydin, A ternary optimisation of mineral additives of alkali activated

cement mortars, *Construction and Building Materials* 43 (2013) 131–138.

- [10] Picandet V, Khelidj A and Bellegou H., (2009) “Crack effects on gas and water permeability of concretes” *Cement and Concrete Research*, vol. 39, pp.537–47.vol. 2, Aug. 1987, pp. 740–741.
- [11] Douglas E, Bilodeau A. and Malhotra VM., (1992) “Properties and durability of alkali-activated slag concrete.” *ACI Materials Journal*, vol. 89(5), pp.509-16.