

Effects of External and Internal Focus of Attention in Motor Learning of Children with Cerebral Palsy

Morteza Pourazar, Fatemeh Mirakhori, Fazlolah Bagherzadeh, Rasool Hemayattalab

Abstract—The purpose of study was to examine the effects of external and internal focus of attention in the motor learning of children with cerebral palsy. The study involved 30 boys (7 to 12 years old) with CP type 1 who practiced throwing beanbags. The participants were randomly assigned to the internal focus, external focus, and control groups, and performed six blocks of 10-trial with attentional focus reminders during a practice phase and no reminders during retention and transfer tests. Analysis of variance (ANOVA) with repeated measures on the last factor was used. The results show that significant main effects were found for time and group. However, the interaction of time and group was not significant. Retention scores were significantly higher for the external focus group. The external focus group performed better than other groups; however, the internal focus and control groups' performance did not differ. The study concluded that motor skills in Spastic Hemiparetic Cerebral Palsy (SHCP) children could be enhanced by external attention.

Keywords—Cerebral Palsy, external attention, internal attention, throwing task.

I. INTRODUCTION

OVER the past decade, numerous studies have examined different ways to improve motor performance and learning [1]. There has been converging evidence demonstrating significant impact of attentional focus on motor learning [2]-[5]. Also, studies have recently begun examining how attention affects properties of the movement itself, such as muscle recruitment [6]-[8], energetic cost [9], and movement kinematics [10]. Instructions or feedback that direct performers' attention to external focus rather than internal focus have been found to result in greater movement effectiveness [11]. The benefits of an external focus of attention have been demonstrated in a variety of dynamic and isometric tasks including force production [6], [12], [13], golf shooting [14], [15], dart throwing [10], and volleyball serves and soccer kicks [3], with respect to the movement outcomes. There are several lines of evidence for the advantages of external focus of attention. For instance, faster probe reaction times [16], lower electromyographic (EMG) activity [10], [17]-[19], as well as enhanced endurance [18] have been shown to be associated with an external relative to an internal focus.

M. Pourazar is a PhD in Department of Physical Education and Sport Sciences, University of Tehran, Kargar Street, Tehran, Iran (corresponding author; phone: +98 9195603836; fax: +98 61118812; e-mail: mortezapourazar@ut.ac.ir).

Fatemeh Mirakhori is a PhD, Fazlolah Bagherzadeh is an Associate Professor, and Rasool Hemayattalab is a Professor in Department of Physical Education and Sport Sciences, University of Tehran, Kargar Street, Tehran, Iran (phone: +98 61118812; fax: +98 61118812).

Children compared to adults are similar to novice players in their lack of tasks experience, with difficulties focusing their attention during motor performance [20]. Attentional focus effects on motor learning in children have only been examined in a few studies. For example, better movement form in a study by Wulf et al. was found for external group [21]. However, Emanuel et al. found similar performance between the internal and external focus of attention among children, even the advantage of internal focus during the transfer phase [22]. Also, in the study by Abdollahipour et al., internal focus condition had lower errors during practice and external focus condition showed faster MT during transfer [23]. Based on the mentioned studies, effects of different attentional focus instruction on children have been related with conflicting results.

Few studies have focused on the role of attentional focus in individuals with motor impairments such as Parkinson's disease [24], [25], Stroke [26], intellectual disabilities [1], and Developmental Coordination Disorder [27]. For example, no apparent difference was found between internal and external focus of attention during retention and transfer tests in children with Developmental Coordination Disorder, while there was a benefit for external focus of attention condition in typically developing children [27]. By reviewing the previous studies, effect of internal versus external focus of attention have not been examined in children with movement disability such as children with Cerebral Palsy (CP). Thus in the present study, there was an attempt to address this issue by studying focus of attention in CP children.

CP is a congenital neurological disorder and the possibility of its occurrence is from conception to two years after birth [28]. Hemiplegia is a form of spastic CP in which one arm and leg on either the right or left side of the body is affected [29]. It is the most common syndrome in children born at term and is second in frequency only to spastic diplegia among preterm infants [29]. Also, children with Hemiplegic Cerebral Palsy (HCP) have an impaired ability to reach, grasp, transport, release and manipulate objects, which impacts on many daily life activities [28]. Adequate treatment planning is imperative to improve their arm and hand function and independence in life, and should be based upon an extensive evaluation of the upper limb [30]. Researchers have shown that children with CP have less force production, coordinated movements and efficiency of hands transportation toward targets [31]-[33].

Research findings related to children with CP showed their ability in learning motor skills [34], [35]. For example, Hemayattalab and Rashidi studied a new motor skill in individuals with CP and concluded that they could learn

throwing dart [34]. Effects of task context and lack of prediction planning was examined by Mutsaerts et al. in individuals with HCP [35]. Results showed that lack of prediction planning in the participants with CP had been caused by the impairment in motor imagery; as an alternative strategy, they used information directly available in the task context [35]. Therefore, learning a new motor skill by directing their attention toward their body movement or the apparatus might be challenging to them [35]. So, the question pursued here is whether attention in children with CP is affected by this impairment in motor imagery resulting to the same effects of external and internal focus of attention [27], the advantage of internal focus of attention [22], or the advantages of external focus of attention like typically developing children [36]. Since participant's attention in the present study was directed to the task (movement outcome versus body movement) after every 10 trials, the researchers wanted to see if the reminders by feedback would result in the same performance, like typically developing children.

Wulf et al. used the Constrained Action Hypothesis to explain the benefits of adopting an external rather than an internal focus of attention [3]. Based on this hypothesis, when individuals are asked to adopt an internal focus, they try to consciously control their movements, which constrain the motor system and inadvertently disrupt automatic control processes. In contrast, focusing on the movement effect or adopting an external focus allows unconscious or automatic processes to control the movement which result to the more effective performance and learning [3], [7]. In this study, we want to examine whether Constrained Action Hypothesis could be used in children with SHCP. So, we compared the effectiveness of instructions related to the learner's own body movements (internal focus) with instructions related to the effects of the performer's actions on the environment, for example, the experimental apparatus (external focus) in children with SHCP. We hypothesize that instructions referring to the apparatus, that is, to the effects of movements, would be more effective than instructions directing performer's attention to the body movements.

II. MATERIALS AND METHODS

A. Participants

Thirty boys ranging from 7 years to 12 years (mean age 10.98; SD = 1.27), with CP type 1, in which only one side of the body had functional disorder and motor disability, and with no previous experience with beanbags throwing, were recruited from a special school for disabled children in Tehran, Iran. Oral assent and written consent were obtained from the participants and their parents/guardians/schools, respectively. The task was novel to the participants and they were unaware of the purpose of the experiment. Inclusion criterion were: diagnosed with Spastic Hemiplegic Cerebral Palsy (SHCP) levels I to III (having self-mobility without a powered wheelchair), as defined by the Gross Motor Function Classification System (GMFCS) [37], the Manual Ability Classification System (MACS) levels I to II [38], without

intellectual disabilities, recognized ability to understand basic verbal communication, and independence from personnel, assistive devices, or support services. Participants were excluded if they showed neurodegenerative diseases, psychiatric illness, traumatic head injury, epilepsy, hearing and visual impairment, and moderate to profound mental retardation that would interfere with their ability to perform the task. Type of CP and diagnosis were determined and classified by pediatric orthopedicians and rehabilitation medicine physicians. The preferred hand was determined by asking participants about their favorite hand for drawing or writing; participants were asked to use their non-dominant arm for throwing beanbags toward the target. This is the case because children with CP tend to neglect the affected limb; and as a result, a non-use phenomenon can gradually result in a progressive deterioration of limb functioning [39], [40]. They were also informed that the data gathered in this study would be kept completely private. There was no difference in ethnicity between the two groups of CP children; they were all Iranian. The study was approved by the university's ethics committee.

B. Apparatus and Task

Participants were instructed to use their non-dominant arm for throwing beanbags (100 g) overhand at a vertical target (bull's eye) [1]. The target height (the bull's-eye) was 1.2 m and it was placed 2 m from the participant. The subjects were asked to always aim at the center of the bull's-eye, which had a radius of 10 cm. The accuracy of throwing was assessed by concentric circles (radii of 20, 30, 40 ... 90, and 100 cm, respectively) around the bull's-eye. Points of 100 were given if bean bag hit in the center of the target, a point 0 for outside of the target, and points of 90, 80, 70, etc., respectively, in areas around the target. The higher score was recorded if the bean bag hit the line. In the pretest, acquisition, and retention phases, the target distance was the same (2 m). However, the distance was increased by 1 m in the transfer phase (Fig 1).

C. Procedure

Basic instructions about how to perform an overarm throwing with non-dominant hand were given to all participants. The experiment was performed individually in a quiet room. The technique of throwing beanbags and target scores were explained and demonstrated by the experimenter prior to the practice. Participants were randomly divided into three groups (internal focus, external focus, and control). The participants in the internal focus group received instructions to direct their attention to the movement of the shoulder, arm, and fingers. The participants in the external group were instructed to direct their attention to the target, beanbag, and beanbag course. While throwing the beanbag, participants in the external focus group were asked to concentrate on its flight directly towards the target, focus on the beanbag (how it feels, its weight, and its position) and look at the target after every 10 trials; participants in the internal focus group were instructed to focus on how their shoulder, arm, and fingers feel before and during the throw. All participants performed a pretest consisting of 10 trials. The practice phase included six

10-trial blocks (60 trials in total), with 2-min rest periods between blocks. In acquisition phase, the instructions regarding the focus of attention were repeated after every 10th trial throughout the relevant condition focusing on the arm movement (internal focus group) or the beanbag movement (external focus group) during the trials. During the internal focus condition, the statement "focus on the throwing hand" and during the external focus condition, the statement "focus on the beanbag movement" were provided by the

experimenter. Since the attentional focus instructions were given to the participants every 10th trial, a manipulation check regarding how to perform focus instructions was not used. Our assumption was that simple and repetitive instruction in the study would have no difficulties for CP children. Retention and transfer tests were performed One day later, consisting of 10 trials. In these phases, participants did not receive any reminders or instructions.

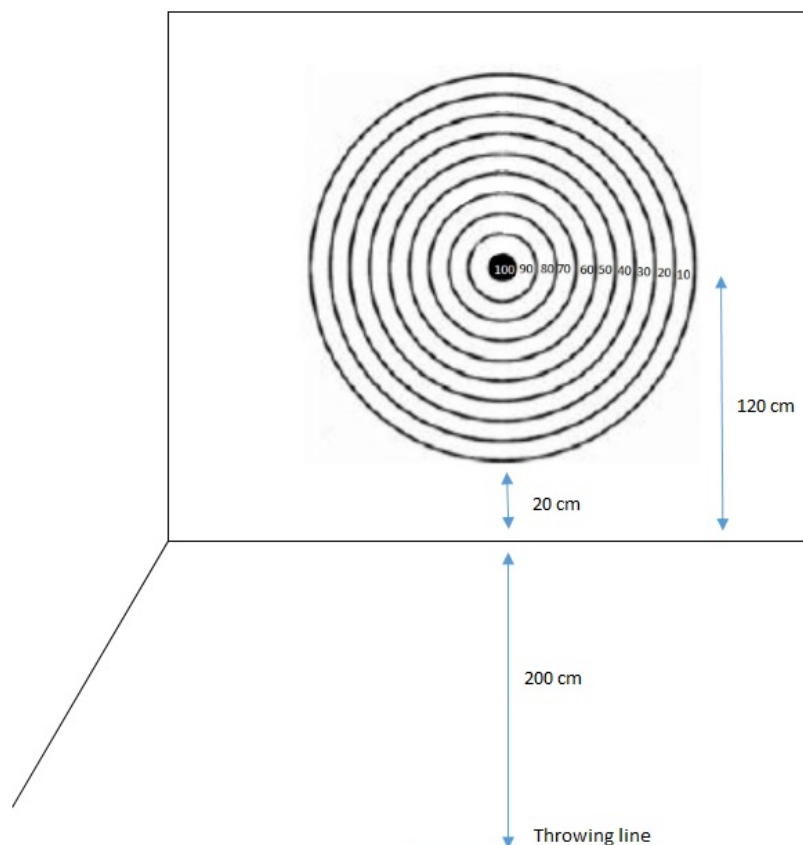

Fig. 1 Schematic of the bull's-eye and score zones

D. Data Analysis

Descriptive analysis was conducted to characterize the basic properties of the observed variables. Average scores were analyzed by 3 (groups: external focus, internal focus, and control) x 3 (times: pretest, retention, and transfer) ANOVA with repeated measures on the last factor. Bonferroni and Tukey tests were used for follow-up analyses. The level of significant was set at 0.05. Statistical analysis was conducted using SPSS 18.

III. RESULTS

Normality, homogeneity of variance, and sphericity, for the repeated-measures ANOVA were met. Participant demographics and descriptive statistics are presented in Tables I and II. Based on the results of Kolmogorov-Smirnov (k-s) test, data distribution in pre-test phase was normal and the groups were not significantly different on certain demographic

variables (e.g., Age, Weight, Height, etc.).

TABLE I
 PARTICIPANT DEMOGRAPHICS

Groups	External	Internal	Control
N	10	10	10
Age(M+ SD)	10.70+ 1.41	11.10+ 0.87	11+ 1.52
Weight(M+ SD)	32+ 3.77	35+ 2.96	34+ 3.80
Height(M+ SD)	131+ 4.61	132+ 3.35	130+ 3.22
handedness	right(n=8) left(n=2)	right (n=9) left (n=1)	right(n=9) left (n=1)
MACS levels	Level I(n=6) level II(n=4)	Level I(n=7) level II(n=3)	Level I(n=6) level II(n=4)
GMFCS levels	level I (n=6) level II(n=3) level III (n=1)	level I (n=5) level II(n=4) level III (n=1)	level I (n=6) level II(n=2) level III (n=2)

As shown in Fig. 2, all groups showed an increase in scores, with the external-focus groups having higher scores than the internal-focus and control groups at the end of practice

(external focus: 35; internal focus: 32; control: 29). Preliminary tests of the assumptions of the statistical tests, including normality and homogeneity of variance for the repeated-measures ANOVA were met.

TABLE II
DESCRIPTIVE INFORMATION

Group	Test	N	Mean	SD
External	Pretest	10	17	4.83
	retention	10	33	7.14
	Transfer	10	25	7.45
Internal	Pretest	10	21	5.16
	retention	10	25	6.66
	Transfer	10	17	4.83
Control	Pretest	10	19	6.14
	retention	10	22	6.74
	Transfer	10	15	5.27

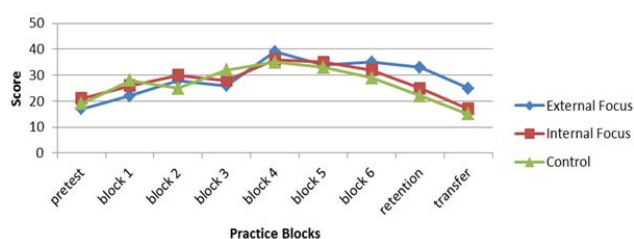

Fig. 2 Participant's performances graphs according to the type of focus

Based on the results of ANOVA with repeated measure, significant main effects were found for time, $F(2, 54) = 7.31$, $p = 0.002$, $\eta^2 = 0.21$ and group $F(2, 27) = 8.90$, $p = 0.001$, $\eta^2 = 0.39$. However, the interaction of time and group was not significant $F(4, 54) = 2.08$, $p = 0.09$, $\eta^2 = 0.13$ (see Table III).

TABLE III
RESULTS OF ANOVA WITH REPEATED MEASURE

	Sum of Square	df	Mean Square	F	p	η^2
time	1175.55	2	587.778	7.31	0.002*	0.21
group	615.55	2	307.778	8.90	0.001*	0.39
time*group	671.11	4	167.778	2.08	0.09	0.13

* Significant differences ($p < 0.05$)

As shown in Table IV, Bonferroni follow up test showed that retention scores were significantly higher than pretest scores only for the external focus group (0.002). However, there were no significant differences recorded between the pretest and transfer scores in all groups.

TABLE IV
RESULTS OF BONFERRONI FOLLOW UP TEST

group	time1	time2	Mean Difference	Std. Error	Sig
External	pretest	retention	-16	3.78	0.002*
	pretest	transfer	-8	3.48	0.23
Internal	pretest	retention	-4	3.23	0.95
	pretest	transfer	4	4.04	0.84
Control	pretest	retention	-3	4.89	1.000
	pretest	transfer	4	3.63	0.90

* Significant differences ($p < 0.05$)

As shown in Table V, Tukey follow up test on the experimental groups indicated that the external focus group differed from both the internal focus ($p = 0.036$) and control groups ($p = 0.001$), and the external group performed more consistently and accurately than the internal and control groups. However, the internal focus and control groups' performances did not differ ($p = 0.29$).

TABLE V
RESULTS OF TUKEY FOLLOW UP TEST

Test	Groups	Mean Difference	Std. Error	P
External	Internal	4	1.518	0.036*
	Control	6.33	1.518	0.001*
Internal	Control	2.33	1.518	0.29

* Significant differences ($p < 0.05$)

IV. DISCUSSION

Motor learning and control research has consistently demonstrated that prompting an external rather than an internal focus of attention leads to superior motor skill learning and performance [41]. However, it was unclear whether children with CP would benefit from external relative to internal focus instructions.

The results of the present study showed significantly higher scores in the retention phase than pretest only for the external focus group. However, there were not significant differences between pretest and transfer scores in all groups. These results were largely in agreement with the findings by Schmidt & Lee and Wulf [42], [43]. Schmidt & Lee asserted that a greater degree of automaticity in movement control, such as what postulated for an external focus, is generally associated with reduced attention demands [42]. Also, Wulf showed not only more movement accuracy, but also more movement efficiency by an external focus of attention [43]. However, in the present study, the throw distance was increased by 1 m and the therapist gave no instructions to the participant in the transfer phase. The lack of significant difference between pretest and transfer scores might be due to the difficulty of performing the throwing task for children with CP by increasing the distance in the transfer phase (3m versus 2m). Also, they appeared to lose interest in the task. There is a possibility that the feelings of frustration in children with CP might manifest as lack of focus and effort which lead to the same performance of groups between the pretest and transfer phase. This finding showed that in preparation of transfer situations, the physical condition of children with CP should be considered. Also, the results of this study showed that the external group was superior to the control and internal focus groups. These findings were in line with the claim and corresponding findings that adopting an external focus of attention is beneficial for the learning of motor skills. For example, Wulf et al.; McNevin and Wulf; McNevin et al. asserted that an internal focus might be detrimental because it may disrupt the 'automatisms' [2], [3], [44]. Also, research findings demonstrated that an internal focus on body movements and associated conscious control attempts lead to superfluous muscular activity that is detrimental to performance [6], [8]. Like the results of the

present study, Hadler et al. showed that the external focus group demonstrated greater accuracy in hitting a target relative to the internal and control groups in retention [21]. However, Jarus et al. showed no significant difference between internal and external focus of attention during retention and transfer for the children with DCD [27]. Children in the present study like typically developing children in the study by Hadler et al. were able to use the advantages of external focus [21]. On the other hand, inconsistent findings with Jarus et al. might be attributed to the participant difference in the type of disability [27]. Also, in a case study by Carson et al. -inconsistent with the present findings- athletes improved their performance by internal focus of attention but they did not include comparisons with external focus [45]. Wulf believes conclusive evidence could be provided only through experiments that include different types of attentional focus instructions (e.g., internal, external) [46].

Based on the memory drum theory, although the focus of studies by Henry was on performance and stimulus rather than learning and result of the action [47], like the present study, their findings demonstrated that focusing on external aspect of the movement could be more effective than movement itself [4]. Accordance with constrained action, external focus in children with CP induced a conscious type of control, and as a consequence, they tended to constrain their motor system by interfering with automatic control mechanisms [3]. In contrast, children with CP focusing on the movement effect promoted a more automatic mode of control. It allowed for the utilization of unconscious, fast and reflexive control processes, with the result that the desired outcome was achieved almost as a by-product [3], [10].

The control group has always had similar performance as internal focus group and weaker performance than the external focus group in the previous studies [4], [11], [25]. Interestingly, these results were the same for the present study in children with CP. The lack of difference between the internal and control groups in our study might be due to the fact that internal group participants tried to consciously control their movements, which constrains the motor system and inadvertently disrupts automatic control processes. The control group participants, on the other hand, who were not given any focus instruction regarding the throwing task, could basically dedicate all of their attentional resources to the throwing task. Thus, the results of the present study showed the advantages of external focus for children with SHCP. It should be noted that these children suffer from less movement limitations compared with other types of CP. So, the benefits of this attentional focus are challenging in a wide society of CP. Based on the present results, the advantages of external attentional focus could only be generalized to children with SHCP. The capacity to successfully participate in such activities can provide important opportunities for children with SHCP allowing them to further improve their motoric competencies. Yet, the limitations of the current study were the number of participants (30 individuals), age range (7 to 12 years old), and type of cerebral palsy (SHCP). Future studies are necessary to examine the effects of attentional focus on

movement efficiency in other types of CP.

V. CONCLUSION

The present results demonstrate how the wording of instructions can impact on sport skill learning in children with SHCP. Directing attention externally through instructions or feedback enhances learning not only in typically developing children, but also in children with disability.

ACKNOWLEDGEMENTS

The authors would like to thank the CP children and their parents for their cooperation, and the staff of the participating centers (special schools in Tehran) for their collaboration.

REFERENCES

- [1] Chiviawosky, S., Wulf, G., & Ávila, L. (2013). An external focus of attention enhances motor learning in children with intellectual disabilities. *Journal of Intellectual Disability Research*, 57, 627-634.
- [2] McNevin, N. H., Shea, C. H., & Wulf, G. (2003). Increasing the distance of an external focus of attention enhances learning. *Psychological Research-Psychologische Forschung*, 67, 22-29.
- [3] Wulf, G., McConnel, N., Gärtner, M., & Schwarz, A. (2002). Enhancing the learning of sport skills through external focus feedback. *Journal of Motor Behavior*, 34, 171-82.
- [4] Wulf, G., Höß, M., & Prinz, W. (1998). Instructions for motor learning: differential effects of internal versus external focus of attention. *Journal of Motor Behavior*, 30, 169-79.
- [5] Wulf, G., Lauterbach, B., & Toole, T. (1999). The learning advantage of an external focus of attention in golf. *Research Quarterly for Exercise and Sport*, 70, 120-126.
- [6] Lohse, K. R., & Sherwood, D. E. (2012). Thinking about muscles: The neuromuscular effects of attentional focus on accuracy and fatigue. *Acta Psychologica*, 140, 236-245.
- [7] Vance, J., Wulf, G., Töllner, T., McNevin, N. H., & Mercer, J. (2004). EMG activity as a function of the performer's focus of attention. *Journal of Motor Behavior*, 36, 450-459.
- [8] Zachry, T., Wulf, G., Mercer, J., & Bezodis, N. (2005). Increased movement accuracy and reduced EMG activity as the result of adopting an external focus of attention. *Brain Research Bulletin*, 67, 304-309.
- [9] Schücker, L., Hagemann, N., Strauss, B., & Völker, K. (2009). The effect of attentional focus on running economy. *Journal of Sport Sciences*, 27, 1241-1248.
- [10] Lohse, K. R., Sherwood, D. E., & Healy, A. F. (2010). How changing the focus of attention affects performance, kinematics, and electromyography in dart throwing. *Human Movement Science*, 29, 542-555.
- [11] Freudenheim, A. M., Wulf, G., Madureira, F., & Corrêa, U. C. (2010). An external focus of attention results in greater swimming speed. *International Journal of Sports Science & Coaching*, 5, 533-542.
- [12] Ashraf, R., Aghdasi, M. T., Sayyah, M., & Taghibiglo, N. (2012). The Effects of Internal and External Focus of Attention on Children's Performance in Vertical Jump Task. *International Journal of Basic Sciences & Applied Research*, 1, 1-5.
- [13] Marchant, D. C., Greig, M., & Scott, C. (2009). Attentional focus instructions influence force production and muscular activity during isokinetic elbow flexion. *Journal of Strength and Conditioning Research*, 23, 2358-2366.
- [14] Bell, J., & Hardy, J. (2009). Effects of attentional focus on skilled performance in golf. *Journal of Applied Sport Psychology*, 21, 163-177.
- [15] Wulf, G., & Su, J. (2007). External focus of attention enhances golf shot accuracy in beginners and experts. *Research Quarterly for Exercise & Sport*, 78, 384-389.
- [16] Abernethy, B. (1988). Dual-task methodology and motor skills research: some methodological constraints. *Journal of Human Movement Studies*, 14, 101-132.
- [17] Marchant, D. C., Clough, P., & Crawshaw, M. (2007). The effects of attentional focusing strategies on novice dart throwing performance and their task experiences. *International Journal of Sport and Exercise Psychology*, 5, 291-303.

- [18] Marchant, D. C., Clough, P. J., Crawshaw, M., & Levy, A. (2009). Novice motor skill performance and task experience is influenced by attentional focusing instructions and instruction preferences. *International Journal of Sport and Exercise Psychology*, 7, 488–502.
- [19] Wulf, G., & Lewthwaite, R. (2010). Effortless motor learning? An external focus of attention enhances movement effectiveness and efficiency. In B. Bruya (Ed.), *Effortless attention: A new perspective in attention and action* (pp. 75–101). Cambridge, MA: MIT Press.
- [20] Mohamadi, J., Kordi, H., & Ghotbi, M. (2012). "The effects of attentional focus strategies on acquisition, retention and transfer of dart throwing task in children and adolescences". *European Journal of Sports and Exercise Science*, 1, 26-32.
- [21] Hadler, R., Chiviacowsky, S., Wulf, G., & Schild, J. (2014). Children's learning of tennis skills is facilitated by external focus instructions. *Motriz*, Rio Claro, 20, 418-422.
- [22] Emanuel, M., Jarus, T., & Bart, O. (2008). Effect of focus of attention and age on motor acquisition, retention, and transfer: A randomized trial. *Physical Therapy*, 88, 251-260.
- [23] Abdollahipour, R., Bahram, A., Shafizadeh, M., & Khalaji, H. (2008). "The effects of attentional focus on the learning of a soccer dribbling-task in children and adolescences". *Journal of Movement Sciences & Sports*, 1, 83-92.
- [24] Landers, M., Wulf, G., Wallmann, H., & Guadagnoli, M. A. (2005). An external focus of attention attenuates balance impairment in Parkinson's disease. *Physiotherapy*, 91, 152–185.
- [25] Wulf, G., Landers, M., Lewthwaite, R., & Töllner, T. (2009). External focus instructions reduce postural instability in individuals with Parkinson disease. *Physical Therapy*, 89, 162–168.
- [26] Fasoli, S. E., Trombly, C. A., Tickle-Degnen, L., & Verfaellie, M. H. (2002). Effect of instructions on functional reach in persons with and without cerebrovascular accident. *American Journal of Occupational Therapy*, 56, 380–390.
- [27] Jarus, T., Ghanouni, P., Abel, R. L., Fomenoff, S.H. L., Lundberg, J., Davidson, S., Caswell, S., Bickerton, L., & Zwicker, J. Z. (2015). Effect of internal versus external focus of attention on implicit motor learning in children with developmental coordination disorder. *Research in Developmental Disabilities*, 37, 119 – 126.
- [28] Kulak, W., & Sobaniec, W. (2004). Comparisons of right and left Hemiparetic Cerebral Palsy. *Pediatric Neurology*, 31, 101–108.
- [29] Hemayattalab, R., Arabameri, E., Pourazar, M., Dehestani Ardakani, M., & Kashefi, M. (2013). Effects of self-controlled feedback on learning of a throwing task in children with spastic hemiplegic cerebral palsy. *Research in Developmental Disabilities*, 34, 2884–2889.
- [30] Jaspers, E., Desloovere, K., Bruyninckx, H., Klingels, K., Molenaers, G., Aertbelie, E., Gestel, L.V., & Feys, H. (2011). Three-dimensional upper limb movement characteristics in children with hemiplegic cerebral palsy and typically developing children. *Research in Developmental Disabilities*, 32, 2283–2294.
- [31] Chang, J. J., Wu, T. I., Wu, W. L., & Su, F. C. (2005). Kinematical measure for spastic reaching in children with cerebral palsy. *Clinical Biomechanics*, 20, 381–388.
- [32] Chen, Y. P., & Yang, T. F. (2007). Effect of task goals on the reaching patterns of children with cerebral palsy. *Journal of Motor Behavior*, 39(4), 317–324.
- [33] Van der Heide, J., Fock, J., Otten, B., Stremmelaar, E., & Hadders-Algra, M. (2005). Kinematic characteristics of reaching movements in preterm children with cerebral palsy. *Pediatric Research*, 57(6), 883–889.
- [34] Hemayattalab, R., & Rashidi Rostami, L. (2010). Effects of frequency of feedback on the learning of motor skill in individuals with cerebral palsy. *Research in Developmental Disabilities*, 31, 212–217.
- [35] Mutsaerts, M., Steenbergen, B., & Bekkering, H. (2006). Anticipatory planning deficits and task context effects in hemiplegic cerebral palsy. *Experimental Brain Research*, 172, 151–162.
- [36] Wulf, G., Chiviacowsky, S., Schiller, E., & Ávila, L.T. (2010). Frequent external-focus feedback enhances learning. *Frontiers in Psychology* 1, 190. doi: 10.3389/fpsyg.2010.00190.
- [37] Palisano, R. J., Hanna, S. E., Rosenbaum, P. L., Russell, D. J., Walter, S. D., & Wood, E. P. (2000). Validation of a model of gross motor function for children with cerebral palsy. *Physical Therapy*, 80, 974–985.
- [38] Eliasson, A.C., Krumlinde-Sundholm, L., Rösblad, B., Beckung, E., Arner, M., Öhrvall, A.M., & Rosenbaum, P.L. (2006). The Manual Ability Classification System (MACS) for children with cerebral palsy: scale development and evidence of validity and reliability. *Dev Med Child Neurol*, 48, 549–554.
- [39] McLaughlin, J.F., Felix, S.D., Nowbar, S., Ferrel, A., Bjornson, K., & Hays, R.M. (2005). Lower extremity sensory function in children with cerebral palsy. *Pediatric Rehabilitation*, 8, 45-52.
- [40] Thibault A., Forget R., Lambert J. (1994). Evaluation of cutaneous and proprioceptive sensation in children: A reliability study. *Developmental Medicine and Child Neurology*, 36: 796-812.
- [41] Wulf, G. (2007). *Attention and Motor Skill Learning*. Human Kinetics, Champaign, IL.
- [42] Schmidt, R. A., & Lee, T. D. (2011). *Motor control and learning* (5th Ed.). Champaign, IL: Human Kinetics.
- [43] Wulf, G. (2013). Attentional focus and motor learning: A review of 15 years. *International Review of Sport and Exercise Psychology*, 6, 77–104.
- [44] McNevin, N. H., & Wulf, G. (2002). Attentional focus on supra-postural tasks affects postural control. *Hum Mov Sci* 21:187–202.
- [45] Carson, H. J., Collins, D., & Jones, B. (2014). A case study of technical change and rehabilitation: Intervention design and interdisciplinary team interaction. *International Journal of Sport Psychology*, 45, 57–75.
- [46] Wulf, G. (2016). An external focus of attention is a conditio sine qua non for athletes: a response to Carson, Collins, and Toner (2015). *Journal of Sports Sciences*, 34 (13), 1293-1295.
- [47] Henry, F. M. (1960). Influence of motor and sensory sets on reaction latency and speed of discrete movements. *Research Quarterly for Exercise and Sport*, 31, 459–468.