

# Ramp Rate and Constriction Factor Based Dual Objective Economic Load Dispatch Using Particle Swarm Optimization

Himanshu Shekhar Maharana, S. K. Dash

**Abstract**—Economic Load Dispatch (ELD) proves to be a vital optimization process in electric power system for allocating generation amongst various units to compute the cost of generation, the cost of emission involving global warming gases like sulphur dioxide, nitrous oxide and carbon monoxide etc. In this dissertation, we emphasize ramp rate constriction factor based particle swarm optimization (RRCPSO) for analyzing various performance objectives, namely cost of generation, cost of emission, and a dual objective function involving both these objectives through the experimental simulated results. A 6-unit 30 bus IEEE test case system has been utilized for simulating the results involving improved weight factor advanced ramp rate limit constraints for optimizing total cost of generation and emission. This method increases the tendency of particles to venture into the solution space to ameliorate their convergence rates. Earlier works through dispersed PSO (DPSO) and constriction factor based PSO (CPSO) give rise to comparatively higher computational time and less good optimal solution at par with current dissertation. This paper deals with ramp rate and constriction factor based well defined ramp rate PSO to compute various objectives namely cost, emission and total objective etc. and compares the result with DPSO and weight improved PSO (WIPSO) techniques illustrating lesser computational time and better optimal solution.

**Keywords**—Economic load dispatch, constriction factor based particle swarm optimization, dispersed particle swarm optimization, weight improved particle swarm optimization, ramp rate and constriction factor based particle swarm optimization.

## I. INTRODUCTION

INTERCONNECTED electric utility is basically meant for attaining minimum cost of generation and emission through a combined objective function satisfying the equality and inequality constraints involving well defined down ramp rate limits and up ramp rate limits with proper constriction factor nonlinear behavior of cost and emission function. The impact of valve point loading gives rise to more perturbation in cost function which can be piecewise-linearized using conventional dispatch techniques. Advanced constriction factor based well defined ramp rate particle swarm optimization (PSO) [17] approach employing heuristic principle is a population-based evolutionary programming technique employing flocks of birds. The added feature through an improved constriction factor has been used to optimize the cost of generation and environmental emission for reducing global warming to great extent. The feasibility of proposed method was demonstrated

Saroj Kumar Dash is with the Gandhi Institute for Technological Advancement, India (e-mail: hodeegita@gmail.com).

for a 6-generating unit system through 30 bus IEEE test case systems. The results obtained through the proposed method were compared with various conventional methods like Lagrange multiplier method [6], [7], mixed integer linear programming method, evolutionary programming method [8]-[10] and quadratic programming method, etc. References [1]-[5] as well with various heuristic methods like PSO, DPSO, WIPSO, etc.

## II. METHODOLOGY

This section forecasts the objective function viz. cost, emission, and combined objective function satisfying equality and inequality constraints involving price penalty factor  $F_i$ . The basic ELD problem is formulated through (1) and (2),

$$Z_i = (a_i PG_i^2 + b_i PG_i + C_i) + K_i \sin(l_i (P_i - PG_i)) \quad (1)$$

$$J_i = (h_i PG_i^2 + g_i PG_i + q_i) \quad (2)$$

where  $Z_i$  and  $J_i$  are the cost and emission objective functions, and  $a_i$ ,  $b_i$ ,  $c_i$ ,  $K_i$ ,  $l_i$  and  $h_i$ ,  $g_i$ ,  $q_i$  are the cost and emission objective function coefficients. In this dissertation, the emission function involves global warming gases like  $\text{NO}_2$  and  $\text{SO}_2$ . The ultimate objective function involving combined objective formulation encompassing cost as well as emission objective function through price penalty factor  $F_i$  is formulated as (3).

$$S_i = Z_i + F_i \times J_i \quad (3)$$

where

$$F_i = \frac{Z_{i\max}}{J_{i\max}} \quad (4)$$

$$Z_i = (a_i PG_i^2 + b_i PG_i + C_i) + K_i \sin(l_i (P_i - PG_i)) \quad (5)$$

$$J_i = (h_i PG_i^2 + g_i PG_i + q_i) \quad (6)$$

The constraints involved in this work are  
 i. Equality constraint

$$\sum_{i=1}^n PG_i = P_D + TL \quad (7)$$

where  $P_D$  = net power demand.

$$TL = \sum_{m=1}^6 \sum_{n=1}^6 PG_m \times PG_n \times B_{mn}$$

where TL is transmission loss.

ii. Inequality constraint

$$P_i \leq PG_i \leq P_j \quad (8)$$

where  $PG_i$  represents the output power of  $i^{th}$  generating unit,  $P_i$  and  $P_j$  are the minimum and maximum output power of  $i^{th}$  generating unit, respectively.

### III. OVERVIEW OF RAMP RATE CONSTRICTION FACTOR BASED PSO

PSO [11], [12] first propounded by Kennedy and Ebert formed the behavior of evolutionary techniques for ELD optimization. Intersecting the valve point strategy employed in the multi objective generation dispatch the nonlinear characteristics of cost objective function and that of emission objective function as well become a challenging issue for ELD optimization. So, in order to obtain optimistic results of nonlinear optimization technique, we incorporate here a ramp rate limit that outsmarts the ordinary inequality constraints through advanced constriction factor based well defined ramp rate PSO technique. This method involves dispersed particles, i.e. swarms [13], [14] in search space randomly updating their position using their velocity heuristically resembling their neighbors so as to obtain position and velocity vectors viz.  $P_{best}$  and  $g_{best}$ , i.e.  $(P_{1best}, P_{2best} \dots P_{ibest})$  and  $(g_{1best}, g_{2best} \dots g_{ibest})$  respectively. The updated values of position and velocity are computed using (9) and (10).

$$Y_{n2}^{(k+1)} = [WY_{n1}^k + C_1 Rand_1(L_0 - S_i^k) + C_2 Rand_2(g_{best} - S_i^k)] \quad (9)$$

$$S_{n1}^{k+1} = S_i^k + V_i^{k+1} \quad (10)$$

where  $C_1, C_2$  are acceleration coefficients,  $W$  = Inertia weight,  $V_i^{k+1}$  = Updated velocity of the  $k+1$  iteration,  $L_0$  =  $P_{best}$  function,  $S_i^k$  = Initial  $i^{th}$  particle after  $k^{th}$  iteration,  $C_1 R$  and  $1(P_{best} - S_i^k)$  = Particle's Private thinking,  $C_2 R$  and  $2(g_{best} - S_i^k)$  = Collaboration amongst particles

$$W = W_{max} - \frac{W_{max} - W_{min}}{k} \times n \quad (11)$$

$K$  = Maximum number of iterations,  $n$  = Iteration number,  $W_{max}$  = Initial Weight in per unit = 0.85,  $W_{min}$  = Final Weight in per unit = 0.35. To optimize the valve point loading effect, the ramp rate constraints are imposed upon the iteration inequality constraints as under.

$$Max(PG_{i_{min}}, P_{i0} - DR_i) \leq PG_{i_{new}} \leq Min(PG_{i_{max}}, P_{i1} + UR_i) \quad (12)$$

Subject to condition that  $P_{gi} - P_{i0} \leq UR_i$  (Generation increases)

$$P_{i0} - P_{i1} \leq DR_i \quad (\text{Generation decreases}) \quad (13)$$

where  $P_{i1}$  = Power generation of  $i^{th}$  unit in the current interval and  $P_{i0}$  = Power generation of  $i^{th}$  unit just before the interval

Looking into the valve point loading, a constriction factor finds use in advanced constriction factor-based well defined ramp rate PSO algorithm given by,

$$CF = \frac{4}{|4 - \Psi - \sqrt{\Psi^3 - \Psi^2 - 3\Psi - 2.2}|} \quad (14)$$

where  $\Psi$  lies between 2.1 and 3.1.

As  $\Psi$  rises, CF decreases giving rise to slower convergence because of diminished population velocity up-gradation using (14)

$$Y_{n2}^{(k+1)} = CF[WY_{n1}^k + C_1 Rand_1(L_0 - S_i^k) + C_2 Rand_2(g_{best} - S_i^k)] \quad (15)$$

#### A. RRCP SO Algorithm

Step 1) Initialize parameters like:

$$PG_1, PG_2, PG_3, PG_4, PG_5, PG_6$$

Step 2) If  $L_i$  is better than  $L_0$ , then

$$L_i = L_{0_{new}} \quad \text{Else} \quad L_i = L_{0_{old}}$$

Step 3) Initialize  $g_{best}$  values for generating units  $PG_1$  to  $PG_6$

Step 4) Assign best of  $L_{i_{new}}$  and  $L_{0_{old}}$  to  $g_{best}$

Step 5) Current position  $S_i = Z_i + F_i \times J_i$  and current velocity

$$Y_{n1} = U_{i_{min}} + Rand_i() (U_{i_{max}} - U_{i_{min}})$$

Step 6) Update position for each particle

$$S_{n1}(k+1) = S_i^k + Y_{n2}^{(k+1)}$$

where  $Y_{n2}^{k+1}$  is the update velocity for each particle

Step 7) If particle position is greater than or equal to bounds in (12) then stop otherwise go to step 2.

#### IV. RESULT ANALYSIS

The results obtained for the proposed RRCPSTO method (Fig. 1) for various objectives viz. cost, emission [16] and combined objective for the IEEE 30 bus test case system through Fig. 1 suggest that beyond 200 MW cost as well as emission objective yields better performance over the classical methods like lambda iteration, mixed integer with linear programming method, and quadratic method, etc. It also outperforms heuristic methods like PSO [15], WIPSO, and DPSO, etc. as illustrated through results obtained in Table III The Simulink model (Fig. 2) and simulated results (over 30 sec) for these objectives (Figs. 3-5) for a thermal power plant yield better performance over other heuristic method.

TABLE I  
COST COEFFICIENTS, UNIT CAPACITY AND EMISSION COEFFICIENTS FOR IEEE 30 BUS TEST CASE SYSTEM WITH 6 GENERATING UNIT

Unit	$a_i$	$b_i$	$c_i$	$P_{i\max} = P_i$
1	0.1424	37.439	755.80	125
2	0.0958	45.144	455.325	170
3	0.0180	39.385	1048.88	225
4	0.0025	37.304	1235.55	235
5	0.0111	35.326	1656.56	320
6	0.0169	37.250	1355.65	390

Unit	$P_{i\min} = P_i$	$h_i$	$g_i$	$q_i$
1	15	0.0039	0.3266	13.84932
2	10	0.0040	0.32667	13.84932
3	30	0.00673	-0.54771	40.2709
4	30	0.00103	-0.54.651	40.2709
5	135	0.00501	-0.5119	42.88553
6	130	0.00501	-0.5119	42.88553

TABLE II  
RESULT OF 6-UNIT SYSTEM FOR A LOAD DEMAND OF 1200 MW INCORPORATING TRANSMISSION LOSS

Unit Power Output	PSO	WIPSO	DPSO	ACWRRPSO
PG <sub>1</sub> (MW)	49.22	50.02	93.02	120
PG <sub>2</sub> (MW)	18.84	20.88	100.02	130
PG <sub>3</sub> (MW)	108.85	110.09	95.00	150
PG <sub>4</sub> (MW)	58.88	60.34	150.47	200
PG <sub>5</sub> (MW)	208.81	210.62	200.05	250
PG <sub>6</sub> (MW)	307.13	308.58	270.55	350
Loss (MW)	55.78	58.89	62.57	46.69
Total Power output	807.51	819.42	971.68	1200
Fuel cost(\$/h)	61115.0	62120.09	63629.22	59626
Emission(T/h)	1026.23	1033.477	1043.458	1020.307
Total cost(\$/h)	100702	100719	100922	100611

TABLE III  
PARAMETERS OF A 6-UNIT TEST CASE THERMAL SYSTEM

Frequency (f) = 60 HZ
$T_{g1}=T_{g2}=0.8$ s
$P_{tie\max}=350$ MW
$T_{r1}=T_{r2}=10$ s
$K_{r1}=K_{r2}=0.5$
$T_{i1}=T_{i2}=0.3$
$K_{p1}=K_{p2}=120$ Hz/ PU MW
$T_{p1}=T_{p2}=1$ S, $a=-0.5$ ; $a_{i2}=-0.5$

TABLE IV  
OPTIMAL SYSTEM PARAMETERS INCORPORATING RRCPSTO TECHNIQUE

Areas under interconnections	Optimal Parameters	Optimal System Parameters using ACWRRPSO technique
Thermal Power system-1	K <sub>p1</sub>	120
	K <sub>i1</sub>	0.02
	B1	1
	R1	1
Thermal Power system-2	K <sub>p2</sub>	120
	K <sub>i2</sub>	0.02
	B2	1
	R2	1
Thermal Power system- 3	K <sub>p3</sub>	120
	K <sub>i3</sub>	0.02
	B3	1
	R3	1
Thermal Power system- 4	K <sub>p4</sub>	120
	K <sub>i4</sub>	0.02
	B4	1
	R4	1
Thermal Power system- 5	K <sub>p5</sub>	120
	K <sub>i5</sub>	0.02
	B5	1
	R5	1
Thermal Power system- 6	K <sub>p6</sub>	120
	K <sub>i6</sub>	0.02
	B6	1
	R6	1

TABLE V  
OPTIMAL PARAMETERS FOR RRCPSTO TECHNIQUE FOR 6 UNIT TEST CASE THERMAL SYSTEM

Sl. No.	Description of parameters	Symbol used	Optimal value of parameters
1	Constriction factor	CF	2.9
2	Acceleration coefficients	C1,C2	2.1
3	Minimum Inertia weight	$W_{\min}$	0.35
4	Maximum Inertia weight	$W_{\max}$	0.85
5	Number of iterations	K	100
6	Random values	$R_1, R_2, R_i$	0.3,0.7,0.5
7	Power Demands	PD	1200 MW
8	Power generation of $i^{th}$ unit just before the current interval	Pi0	80
9	Down Ramp rate limit of $i^{th}$ unit	$DR_i$	44
10	UP Ramp rate limit of $i^{th}$ unit	$UR_i$	1244

TABLE VI  
TRANSMISSION LOSS COEFFICIENTS FOR 6-UNIT TEST CASE THERMAL SYSTEM

Unit	B coefficients (B <sub>ij</sub> )					
	1	2	3	4	5	6
1	1.39	0.16	0.14	0.18	0.25	0.21
2	0.16	0.59	0.12	0.15	0.14	0.19
3	0.141	0.12	0.64	0.16	0.23	0.18
4	0.18	0.15	0.16	0.61	0.29	0.24
5	0.25	0.14	0.23	0.29	0.68	0.31
6	0.21	0.19	0.18	0.24	0.31	0.84

A. Various Objective Functions

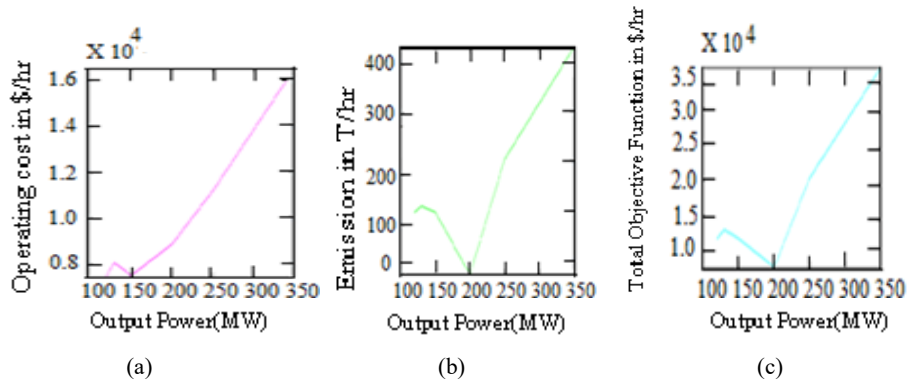

Fig. 1 (a) Operating cost function vs Output Power, (b) Emission level vs Output Power, (c) Total objective function vs. Output power for 30 number of iterations

B. Simulink Model

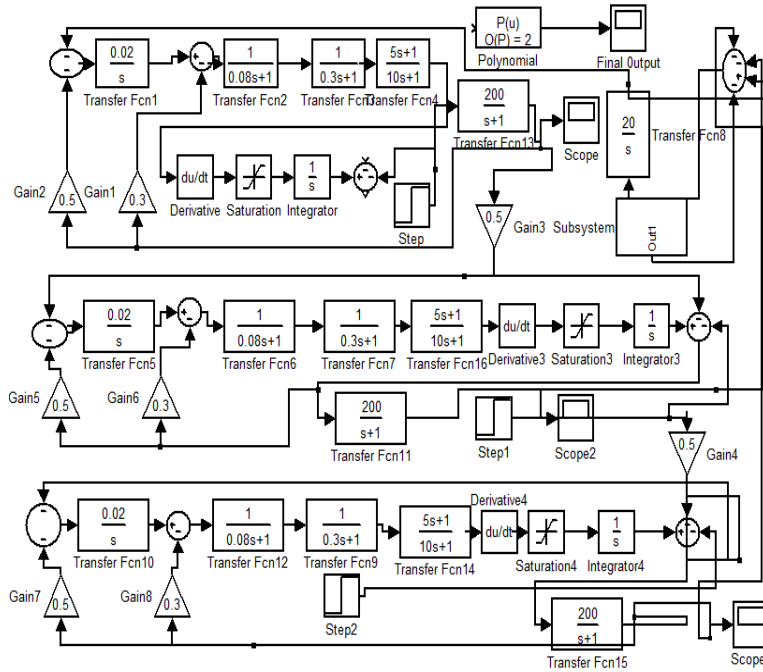

Fig. 2 Simulink Model of various objectives for a thermal power plant

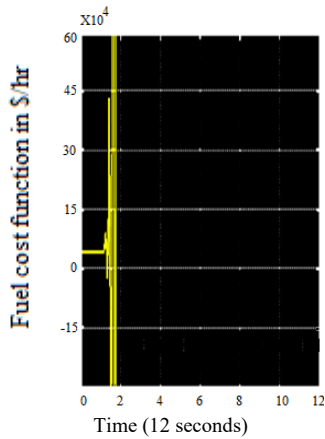

Fig. 3 Fuel cost function of the RRCPSO for 6-generator 30 bus IEEE test case system for demand of 1200 MW

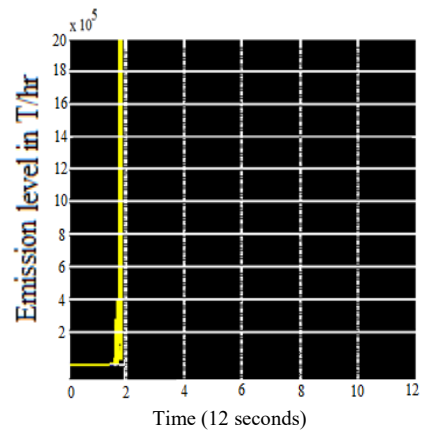

Fig. 4 Emission function for 6-unit 30 bus IEEE test case system

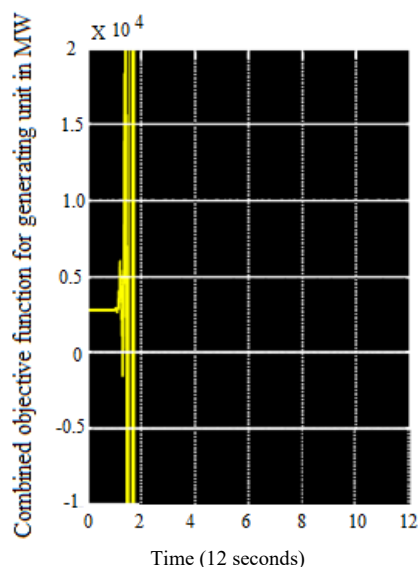

Fig. 5 Combined objective function for 6-unit 30 bus IEEE test case system

## V. CONCLUSION

The proposed method RRCPSO presented advanced PSO technique involving valve point loading, ramp rate constraints, constriction factor based swarm optimization tool box for analyzing the economic dispatch problem. The results of this analysis (Tables I-VI) outperform classical methods like lambda iteration method, mixed integer linear programming method (MILP), quadratic programming method, etc., and heuristic methods like PSO, WIPSO, DPSO, etc. in terms of computational time for better optimal solution.

## REFERENCES

- [1] M. L Jose, L.T Alicia and S.R Jesus, "Short term hydrothermal coordination based on interior point nonlinear programming and genetic Algorithm", *EE Porto power Tech conference*, 2001.
- [2] M. G. CW, Aganagic JG, Tony M Jose B and Reeves S, "Experience with mixed integer linear programming based approach on short term hydrothermal scheduling, *IEEE transaction on power system*, Vol.16 (4), pp.743-749.
- [3] Ng and G. Shelby, "Direct load control –a profit-based load management using linear programming, *IEEE transaction on power system*, Vol.13 (2), pp.688-694, 1998.
- [4] Shi C C, Chun H.C, Fomg I. K and Lah PB, "Hydroelectric generation scheduling with an effective differential dynamic programming algorithm", *IEEE transaction on power system*, Vol.5(3),pp.737-743, 1990.
- [5] Erion Finardi C, Silva Edson LD and Laudiasagastizabal CV. "Solving the unit commitment problem of hydropower plants via Lagrangian relaxation and sequential quadratic programming", *Computational & Applied Mathematics*, Vol. 24(3), pp. .317- 341, 2005.
- [6] D I sun, B Ashley, B Brewer, A Hughes and W.F. Tinney, "Optimal power flow by Newton Approach". *IEEE transaction on power system*, Vol 103(10), pp.2864-2880, 1984.
- [7] Santos and G.R. da Costa, "Optimal power flow by Newton's method applied to an augmented Lagrangian function" *IEE proceedings generations, Transmission & distribution*, Vol 142(1), pp.33-36, 1989.
- [8] N Sinha, R. Chakrabarti and PK Chattopadhyay, "Evolutionary programming techniques for Economic load Dispatch. *IEEE transactions on Evolutionary Computations*," Vol 7(1), pp.83-94, 2003.
- [9] K. P. Wong and J Yuryevich, "Evolutionary based algorithm for environmentally constraints economic dispatch", *IEEE transaction on power system*. " Vol 13(2), pp. 301-306, 1998.

- [10] L Lai & Mata Prasad. Application of ANN to economic load dispatch. *Proceeding of 4<sup>th</sup> international conference on advance in power system control, operation and management, APSCOM-97*, Hong-Kongpp.pp707-711, nov-1997.
- [11] J. Kennedy and R. C. Ebert, "Particle Swarm Optimization," *proceeding of IEEE international conference on Neural networks*, Vol.4, pp.1942-1948, 1995.
- [12] C.H. Chen & S.N. Yeh, "PSO for Economic power dispatch with valve point effects," *IEEE PES transmission & Distribution conference and Exposition*, pp.1-5Latin America, Venezuela, 2006.
- [13] K. S. Swarup, "Swarm intelligence Approach to the solution of optimal power flow," *Indian Institute of science*, pp.439-455, oct- 2006.
- [14] K. T. Chaturvedi, M. panditand L .Srivastava, "Self organizing Hierarchical PSO for non-convex economic load dispatch," *IEEE transaction on power system*, Vol.23(3), pp.1079-1087, Aug.2008.
- [15] P. T. V. Dinhlunge and Joef, "A Novel weight-improved Particle swarm optimization algorithm for optimal power flow and economic load dispatch problem." *IEEE Transaction*, pp.1-7, 2010.
- [16] K. S. Kumar, V.Tamilselvan, N. Murali, R. Rajaram, N.S.Sundaram and T. Jayabharathi, "Economic Load Dispatch with Emission Constraints using Various PSO Algorithms", *WEAS Transactions on power systems*, Vol3(9), pp.598 607, September 2008.
- [17] Hardiansyah, "Solving Economic Dispatch Problem with Valve-Point Effect using a Modified ABC Algorithm", *International Journal of Electrical and Computer Engineering*, Vol 3(3), pp.377-385, June 2013.



**Himanshu Shekhar Maharana** completed his B. Tech degree in EEE from JITM, Paralakemundi under BPUT university, Rourkela, Odisha in 2010 and Completed M. Tech degree in Power System Engineering from GITA, Bhubaneswar under BPUT, Rourkela., Odisha in the year 2014. Prior to it he worked in industry and then worked as an Asst. Professor in the Dept. of Electrical Engineering at Einstein Academy Of Technology & Management, Bhubaneswar for 4 years. Now he is working as an Asst. Professor in the Dept. of EEE at Gandhi Institute Of Excellent Technocrats, Ghangapatna, Bhubaneswar. At present he is continuing Ph.D. degree in BPUT, Rourkela, Odisha under the guidance of professor Dr. S. K. Dash.



**S. K. Dash** received the UG degree in Electrical Engineering from I.E, India in 1991 and accomplished Masters' Program in electrical engineering from UCE, Burla (Sambalpur University), India, in 1998 and the Ph.D. degree from Utkal University, Odisha, India in the year 2006. He has been with the Electrical Engineering Department, Gandhi Institute for Technological Advancement as a Professor and Head of the Department since 2005. Prior to it he worked in industry for 5 years and in OSME, Keonjhar, for 2 years and in Krupajal Engineering College for 4 years. His research interests are power system planning, operation, and optimization techniques applied to power systems. Dr. Dash received Pandit Madan Mohan Malaviya award, Union Ministry of Power Prize and gold medals thereof for his research papers on Multi Objective Generation Dispatch. He too authored two books entitled 'Fundamentals of Electromagnetic Field Theory' and 'Basic Electrical Engineering' under the umbrella of PHI Publication and YESDEE publication in the year 2010 and 2016 respectively. Dr. Dash is engaged as a reviewer of EPCS, and EPSR journals of IEEE.