

Object-Oriented Multivariate Proportional-Integral-Derivative Control of Hydraulic Systems

J. Fernandez de Canete, S. Fernandez-Calvo, I. García-Moral

Abstract—This paper presents and discusses the application of the object-oriented modelling software SIMSCAPE to hydraulic systems, with particular reference to multivariable proportional-integral-derivative (PID) control. As a result, a particular modelling approach of a double cylinder-piston coupled system is proposed and motivated, and the SIMULINK based PID tuning tool has also been used to select the proper controller parameters. The paper demonstrates the usefulness of the object-oriented approach when both physical modelling and control are tackled.

Keywords—Object-oriented modeling, multivariable hydraulic system, multivariable PID control, computer simulation.

I. INTRODUCTION

OBJECT-ORIENTED modelling and simulation is nowadays a major tool to assess the behavior of complex controlled systems. In fact, object-oriented languages and tools are widely used to assist engineering and control synthesis in a number of domains, ranging from mechatronics to hydraulic systems among others [1].

Object-oriented programming is based on a hierarchical classification of procedures and data that allows the modelling of systems in terms of collections of objects [2]. Objects may be grouped into classes which contain generic descriptions of state and behavior, which in turn can be created from existing classes by inheritance.

SIMSCAPE is an object-oriented language for modelling continuous complex physical systems for the purpose of computer simulation, and are primarily based on physical modelling rather than mathematical modelling [3], [4]. They also have multi-domain modelling capability, meaning that model components corresponding to physical objects from several different domains can be described and connected, and many applications have appeared up to date [5], [6].

The task of controlling of multivariable systems is hard since the system under control consists of large number of manipulated and of controlled variables. The controller design is complicated since it is not known a priori the relation between manipulated and controlled variables [7]. The Relative Gain Array (RGA) method represents a practical solution to analyze the interaction between the manipulated and controlled variables, thus enabling the proper pairing needed to build an efficient control structure [8]. At present, the main focus is on standard proportional-integral (PI) and

PID multivariable control that significantly contribute to form the backbone of industrial controls [9], and auto-tuning is commonly considered to tune the controller parameters.

In this paper, it is presented the application of the object-oriented modelling software SIMSCAPE to a multivariable hydraulic system, with particular reference to multivariable PID control by using the RGA approach to select the pairing manipulated and controlled variables. The control scheme is applied on a double cylinder-piston coupled system under SIMSCAPE, and a SIMULINK based PID tuning tool has been used to tune the controller parameters. The results obtained show the effectiveness of the simulation by the physical modeling of the cylinder-piston hydraulic system as well as the ability of the control design tool to deal with problems of the multivariate type.

II. THE OBJECT-ORIENTED MODELLING APPROACH

SIMSCAPE is an object-oriented language where a model is defined as collection of physical blocks appropriately connected to define the system dynamics. A specific connection diagram together with the conservation laws relating blocks dynamics determines the system equations.

Traditional block-oriented simulation software as is SIMULINK represents a causal approach when system modelling is accomplished, in contrast to a causal approach followed by physical modelling [10]. This innovative approach is based on the concept of components connected by special purpose connectors so that the user is not obliged to follow a strict computational order during the modelling phase. In the same way, reuse of model components together with inheritance capabilities provides simplicity to the object-oriented modelling approach here followed [11].

In physical modeling approach, models for different components are developed independently. The interactions between components in a system are through the connectors of the components, in particular through the variables associated with the connectors. The information exchanges between components through connectors are bi-directional, so flow directions do not need to be specified.

Every connector needs to be associated with a connector class. It is important to note that only connectors which belong to the same domain, or class, can be connected together. The variables at a connector class are separated into two types, across and through variables [12]. Across variables are measured with a sensor connected in parallel to a component with respect to a reference, whilst through variables are measured with a sensor connected in series to a component. Application of Kirchoff laws yields the dynamics equations by

J. Fernandez de Canete, S. Fernandez-Calvo, and I. García-Moral are with the Department of System Engineering and Automation, University of Malaga, Spain (phone: +34 951952359, e-mail: ffernandezr@uma.es, sfc@uma.es, gmoral@uma.es).

stating null summation of effort variables in a loop and null summation of flow variables in a junction.

III. THE HYDRAULIC CYLINDER-PISTON MODEL

The goal of this paper is the design of a multivariable control applied to a hydraulic plant constituted by two units of 3-ways directional valves plus double-acting cylinder-piston (Fig. 1) coupled by the connecting link that causes interaction between pistons displacement [13]. The link will be modeled as a spring-damper system so as to create interaction between the two cylinders.

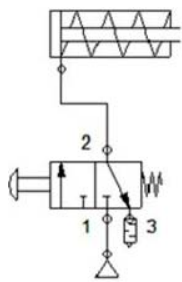

Fig. 1 Schema of 3-ways directional valves plus cylinder-piston

SIMSCAPE libraries contain a large number of basic elements organized by categories. Fig. 2 shows the blocks of the SimHydraulics library that have been used in the elaboration of the double-acting cylinder model with 3-way directional valve.

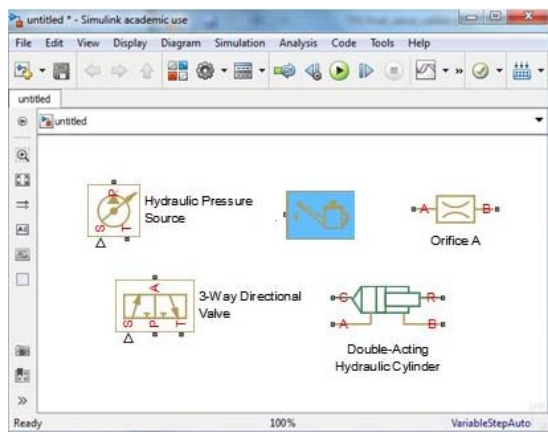

Fig. 2 SIMSCAPE blocks included into SimHydraulics Library

It will be necessary to include SIMULINK-SIMSCAPE signal converters and vice versa and the 'Solver Configuration' block, required for model resolution and connection of inputs and outputs to SIMULINK, so as to model the interaction of the hydraulic model with the multivariable control. By adding the previously defined elements, we obtain the physical model of a double-acting cylinder-piston in SIMSCAPE (Fig. 3).

An opposition to the stroke of the cylinder at the end of the piston is to be modelled (Fig. 4). This is to be done to prevent free movement so as the study has practical interest; otherwise, the displacement of the piston would be instantaneous.

Next, the modeling of the linking connection that will couple the two cylinders is detailed, converting the problem into a multivariate system with two inputs and two outputs. The linking bond will be modeled as a spring-damper system.

Lastly, it is only necessary to properly connect the three systems modeled and add the input signals and the output signals through SIMSCAPE-SIMULINK connection blocks resulting into the complete model (Fig. 5).

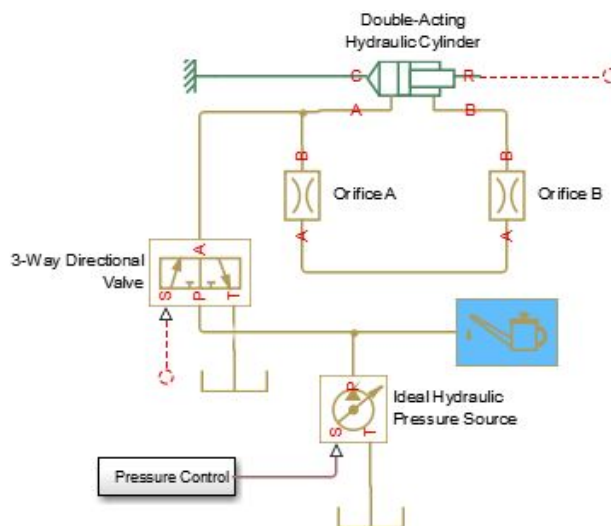

Fig. 3 SIMSCAPE diagram of a double-acting cylinder-piston



Fig. 4 SIMSCAPE modelling of the opposition to the stroke of the cylinder-piston

IV. THE MULTIVARIABLE PID CONTROLLER

The main objective in designing a multivariate control system for an industrial process is to arrive at a structure that minimizes the interaction caused by manipulated variables over other controlled variables.

There are different ways of approaching the problem of calculating controllers in multivariate processes. One of the most widespread ways is to calculate the so-called Relative Gain Matrix (RGA) which provides a quantitative approximation of the analysis of the interactions between control and output [8].

RGA is an analytical tool that is used to determine the input-output pairs of a multivariate process, defined by a gain matrix composed of elements defined as ratios of open-loop to closed-loop gains, so as to find the best pair of manipulated and controlled variables.

In this particular case, a double decoupled PID controller has been designed to control de coupled cylinder-piston hydraulic system (Fig. 6).

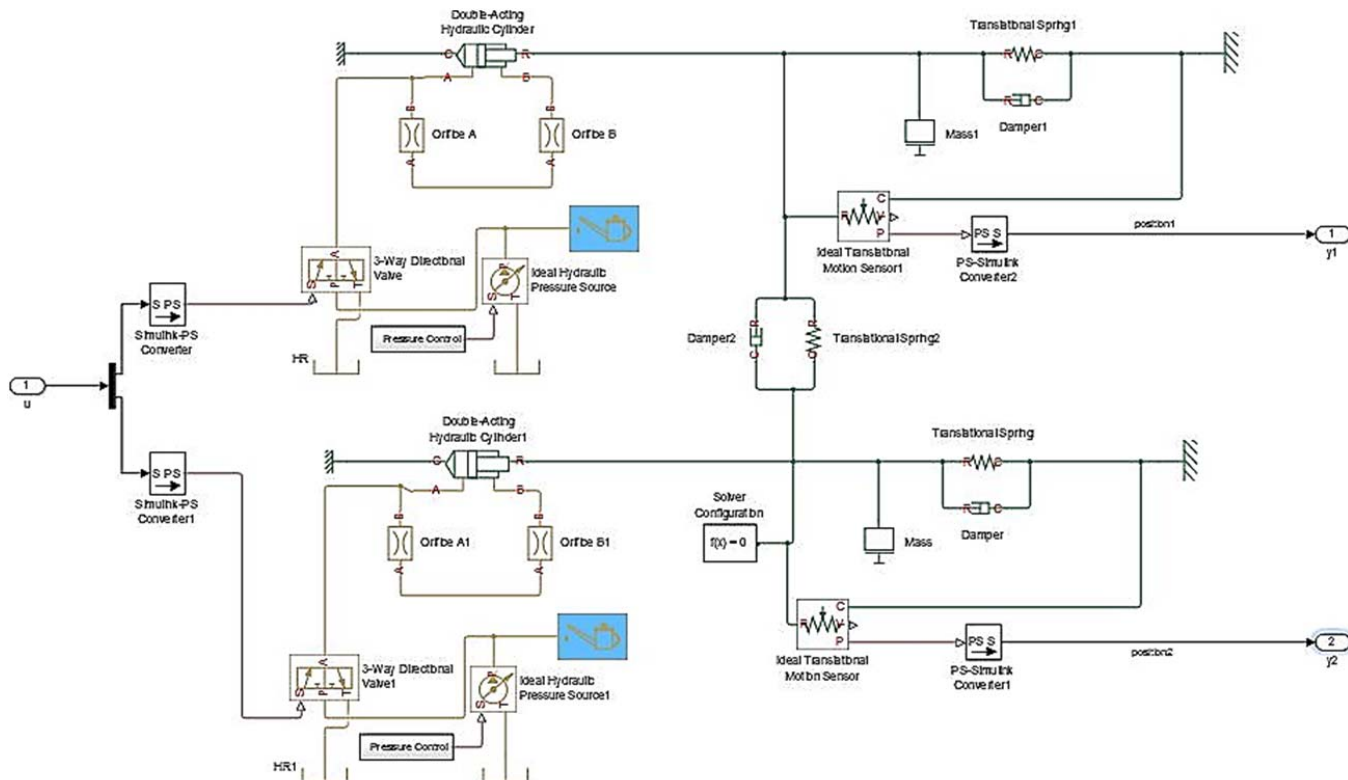

Fig. 5 SIMSCAPE model of the complete double cylinder-piston hydraulic system

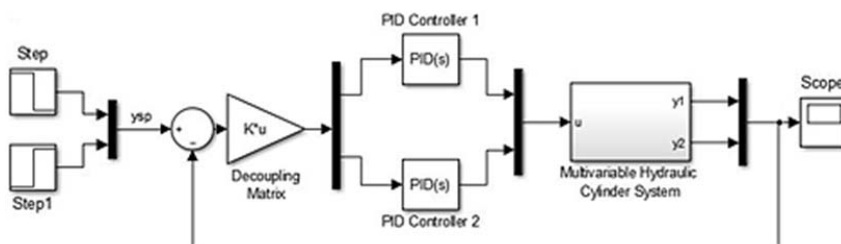

Fig. 6 SIMULINK diagram of double decoupled PID controller acting on the double cylinder-piston

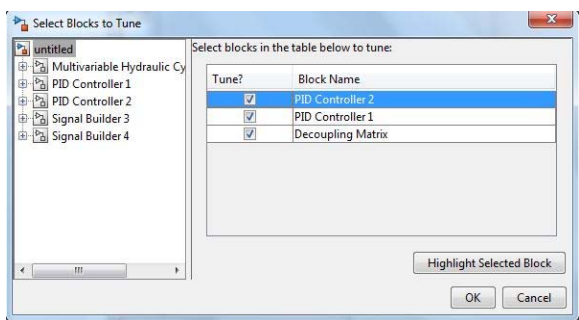

Fig. 7 SIMULINK PID controller tuner

The double PID tuning has been accomplished by using the “PID Tuner” block in SIMULINK according to performance requirements for each cylinder-piston (Fig. 7).

V. SIMULATION RESULTS

In order to test the object-oriented SIMSCAPE multivariable PID control of the cylinder-piston hydraulic

system, several simulations have been realised in both open and closed loops. To start the simulation, initial values of system variables have been assigned.

The first experience was conducted by applying a pulse input in each cylinder-piston system in open-loop, the first one ascending and the other one descending (Fig. 8).

As noted, both cylinders remain unable to bring their piston to the desired position. At the same time, it can also be seen that they do not respond to changes in the set-point, remaining at the same value throughout the simulation.

In the second experience, the control loop is finally closed, and the advantages provided with the tuned multivariable PID control are observed (Fig. 9).

The interaction effect between both cylinders is observed in the slight displacement of the counter cylinder on which the control signal is being affected.

As it is observed, the control action performs correctly, and the set-point tracking is achieved for both cylinder-pistons under SIMULINK PID multivariable control.

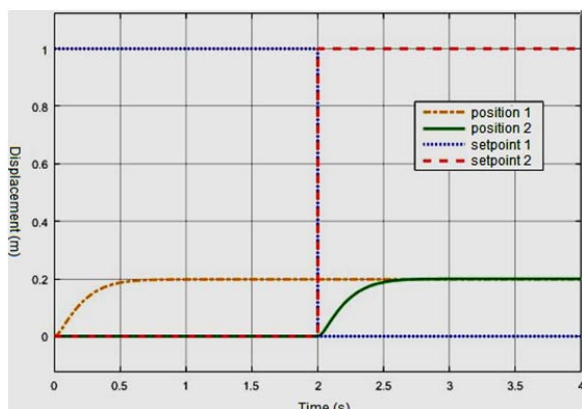

Fig. 8 Open-loop pulse input response of double cylinder

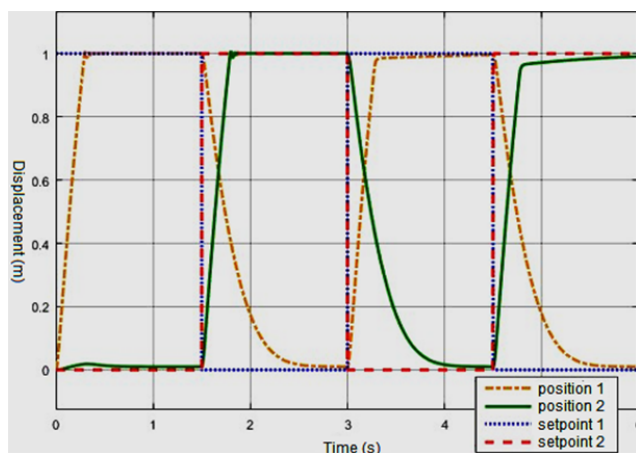

Fig. 9 Closed-loop delayed pulse input response of double cylinder

VI. CONCLUSIONS

The main objectives of the present paper have been the implementation of the model of a multivariable hydraulic system composed of two double-piston cylinder-piston with their corresponding directional valves united by means of a mechanical link that couples the displacement of the two pistons. For this purpose, the SIMSCAPE programming environment has been used through the interconnection of the necessary physical blocks.

Subsequently, the closed-loop control has been performed by defining a RGA matrix that relates the influence of the different control actions on each of the outputs. The design of both this matrix and the PID controllers has been carried out using the 'PID Tuner' SIMULINK tool.

The control system designed resembles the physical reality of the modelled system more closely than the classical interconnected block schemes in SIMULINK. SIMSCAPE language uses a hierarchical modelling strategy, so that modeling effort is considerably reduced and the model reuse is facilitated. Simulation models are also more legible in SIMSCAPE and facilitate an easy comprehension of multivariable control of hydraulic systems.

REFERENCES

[1] T.J. Hassell, W. Weaver, A.M. Oliveira, "Using Matlab's Simscape

modeling environment as a simulation tool in power electronics and electrical machines courses", in: *Frontiers in Education Conference 2013 IEEE*, 2013, pp. 477-483.

- [2] P. Fritzson, *Principles of Object-oriented Modeling and Simulation with Modelica 2.1*, Wiley-IEEE Press, 2003.
- [3] S. Miller, *Modeling Physical Systems as Physical Networks with the Simscape Language*. The MathWorks, 2008.
- [4] D. Xue, Y. Chen, *System Simulation Techniques with MATLAB and SIMULINK*. Wiley, 2014.
- [5] J. Chen, "The Simscape Language and Powertrain Applications", Conference: *SAE World Congress* Detroit, Michigan, 2013.
- [6] E. Jamila, S. Abdelmjid, "Physical Modeling of a Hybrid Wind Turbine-solar Panel System Using Simscape Language", *IJE Trans B: Applications* Vol. 27, No. 11, 2014, pp. 1767-1776.
- [7] P. Albertos, A. Sala, *Multivariable control systems. An engineering approach*. Springer-Verlag, 2004.
- [8] D. Sankaranarayanan, G. Deepakkumar, "Implementing the Concept of Relative Gain Array for the Control of MIMO System: Applied To Distillation Column", in: *Annals University Regional Centre, Coimbatore*, India, 2014.
- [9] K. Astrom, T. Hagglund, *Advanced PID Control*. ISA-The Instrumentation, Systems, and Automation Society, 2006.
- [10] H. Klee, R. Allen, *Simulation of Dynamic Systems with MATLAB and Simulink*, CRC Press, 2011.
- [11] J. Fernandez de Canete, "Object-Oriented Programming for Modeling and Simulation of Systems in Physiology", *International Journal of Medical, Health, Biomedical, Bioengineering and Pharmaceutical Engineering* Vol. 9, No. 4, 2015, pp. 343-346.
- [12] P. Fritzson, *Introduction to Modeling and Simulation of Technical and Physical Systems with Modelica*, Wiley-IEEE Press, 2011.
- [13] C. Mayhew, *Fluid Power: Hydraulics Versus Pneumatics*, <http://slideplayer.com/slide/4771828/>, 2008.