

# Development of PSS/E Dynamic Model for Controlling Battery Output to Improve Frequency Stability in Power Systems

Dae-Hee Son, Soon-Ryul Nam

**Abstract**—The power system frequency falls when disturbance such as rapid increase of system load or loss of a generating unit occurs in power systems. Especially, increase in the number of renewable generating units has a bad influence on the power system because of loss of generating unit depending on the circumstance. Conventional technologies use frequency droop control battery output for the frequency regulation and balance between supply and demand. If power is supplied using the fast output characteristic of the battery, power system stability can be further more improved. To improve the power system stability, we propose battery output control using ROCOF (Rate of Change of Frequency) in this paper. The bigger the power difference between the supply and the demand, the bigger the ROCOF drops. Battery output is controlled proportionally to the magnitude of the ROCOF, allowing for faster response to power imbalances. To simulate the control method of battery output system, we develop the user defined model using PSS/E and confirm that power system stability is improved by comparing with frequency droop control.

**Keywords**—PSS/E user defined model, power deviation, frequency droop control, ROCOF, rate of change of frequency.

## I. INTRODUCTION

IN the power system, sometimes, the frequency drops sharply when disturbances such as rapid increase of system load or loss of a generating unit occur. Recently, the power system stability is very unstable due to increase of the number of renewable generating units. Power deviation between supply and demand from loss of generating unit or rapid increase of load has bad influence to system stability, in the worst case, UFR (Under Frequency Relay) is operated for load shedding. To prevent the above situation, the power deviation is compensated by other generating units such as battery. Connecting the battery system to the power system that renewable generating units are connected is a feasible way to make the power system more stable [1]. Traditionally, battery output is controlled by frequency droop control using frequency characteristic in the transient. However, the power system is very unstable due to increase in the number of renewable generators. Renewable generators output is very unstable because they are highly influenced by climate. So, the

stability of power systems connected with renewable generators is lower. To improve the stability of power system connected with renewable generators, faster power compensation is needed to response the power deviation.

In this paper, we present battery output using ROCOF to compensate the power deviation between supply and demand more quickly. The bigger the power deviation that gives significant impact to stability of power system in the power system, the bigger ROCOF drops. When this characteristic is applied to the battery output, the power deviation can be compensated more quickly. The principle of the battery output using ROCOF simply is that threshold of ROCOF is set previously and the battery outputs in proportion to magnitude of the decreased ROCOF when ROCOF decrease below the threshold. Normally, the battery is controlled by frequency droop control.

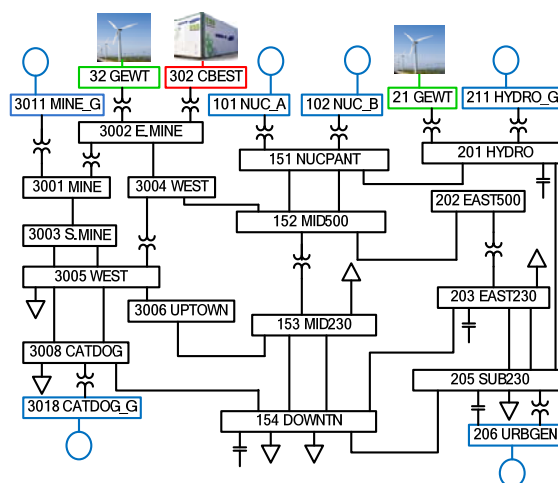

Fig. 1 Power system for simulation with wind farm and battery in PSS/E

To confirm the effect of battery output using ROCOF, PSS/E user defined model to control the battery output is developed and results for various simulations are compared with only frequency droop control for battery output in PSS/E. Used simulation power system model is example power system named as 'savnw' from PSS/E. Additionally, two wind farms and a battery model are connected to example power system as shown Fig. 1.

Dae-Hee Son is a PhD candidate with the Electrical Engineering Department, Myongji University, Yongin, CO 17058 South Korea (corresponding author to provide phone: +82-10-6257-8726; e-mail: sonking18@nate.com).

Soon-Ryul Nam is a Professor with the Department of Electrical Engineering, Myongji University, Yongin, CO 17058 South Korea (e-mail: ptsouth@mju.ac.kr).

## II. EFFECT TO POWER SYSTEM STABILITY BY BATTERY WITH FREQUENCY DROOP CONTROL

As an object of comparison, we conduct the battery output with frequency droop control and confirm the effect of this battery control to the power system stability. The frequency droop control is to increase battery output in proportion to magnitude of frequency deviation from the rated frequency. The battery with frequency droop control is operated when system frequency is out of dead band. Fig. 2 [2] presents the battery output according to change the power system frequency.

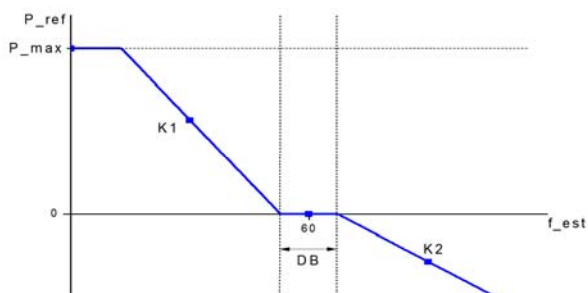

Fig. 2 The battery output with frequency droop control according to the power system frequency [2]

$$\begin{aligned}
 P_{bat} &= k_1 (f - f_n - f_{dead1}) \cdots (f - f_n < f_{dead1}) \\
 P_{bat} &= 0 \cdots \cdots \cdots (f_{dead1} < f - f_n < f_{dead2}) \\
 P_{bat} &= k_2 (f - f_n - f_{dead2}) \cdots (f - f_n > f_{dead2})
 \end{aligned} \quad (1)$$

$P_{bat}$  is the battery output,  $k_1, k_2$  are coefficient of the frequency droop control. In this paper, coefficient of frequency droop is set as 0.5% because battery output is maximum power at 59.7 Hz. System frequency 59.7 Hz is instantaneous minimum frequency after disturbance.  $f_n$  is rate frequency of system 60 Hz in Korea,  $f$  is measured frequency.  $f_{dead1}, f_{dead2}$  are DB (Dead Band) of frequency droop, range of DB is determined as  $60 \pm 0.017$  Hz [3]. User defined model of PSS/E is developed based on (1) for frequency droop control.

To confirm the effect of frequency droop control, we have used CBEST battery model supplied from PSS/E and simulated several cases. The structure of the CBEST battery model is shown in Fig. 3.

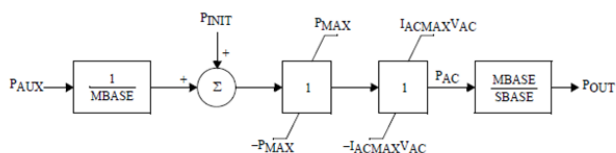

Fig. 3 Diagram of CBEST battery model from PSS/E [4]

The CBEST battery output is controlled by  $P_{AUX}$  and  $P_{INIT}$ .  $P_{AUX}$  is input value,  $P_{INIT}$  is initial value of the CBEST battery model. The others are values of output range. In this paper, initial value  $P_{INIT}$  is set as 0; input value  $P_{AUX}$  is set by frequency droop control. The other setting values are shown in

[5].

The capacity of CBEST battery model is set as 30 MW, initial power system load is set as 2500 MW and initial battery output is set as 0 MW for simulation.

After 30 second simulation begin, the system load is increased by 5 MW to check the battery with the frequency droop control operation and to confirm the effect on the system when the system frequency stays in the DB. Then, there is no battery output; therefore, the power system frequency changes the same as the no battery system.

After 60 second from the start of simulation, system load is increased by 5% of total load to check the battery with frequency droop control operation and to confirm the effect on the system when the system frequency is out of the DB. Then, the battery output is increased depending on the frequency droop control. It can be confirmed that when the battery with frequency droop control is connected to the system, the system frequency stability is little improved than none.

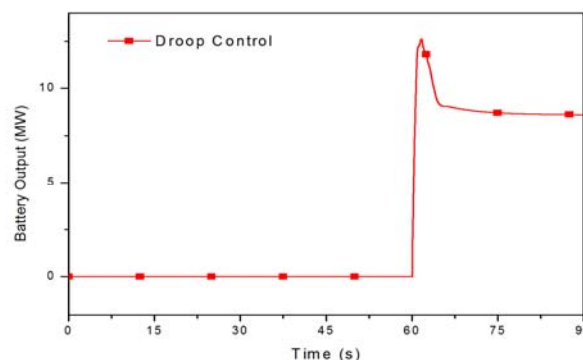

Fig. 4 The battery with frequency droop control output according to increase the system load

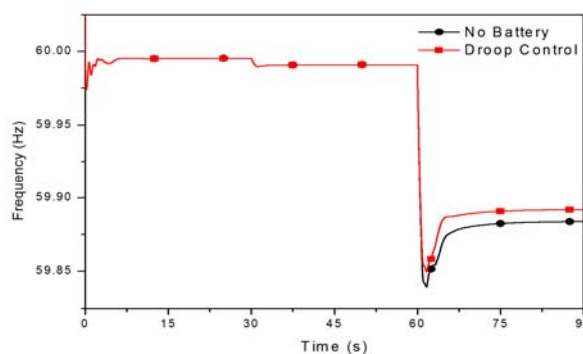

Fig. 5 The system frequency according to increase the system load

In the next chapter, the system frequency stability is more improved by the battery using ROCOF.

## III. EFFECT TO THE POWER SYSTEM STABILITY BY BATTERY USING ROCOF

To improve the system stability, power deviation between supply and demand is compensated more quickly after rapid load increase or loss the generating units. So, the method using the ROCOF should be applied to the battery output control. The

bigger the power deviation that gives significant impact to stability of power system in the power system, the bigger ROCOF drops. So, battery output is increased in proportion to the magnitude of ROCOF drop when ROCOF drop down below the threshold. Normally, the battery output is controlled by frequency droop control.

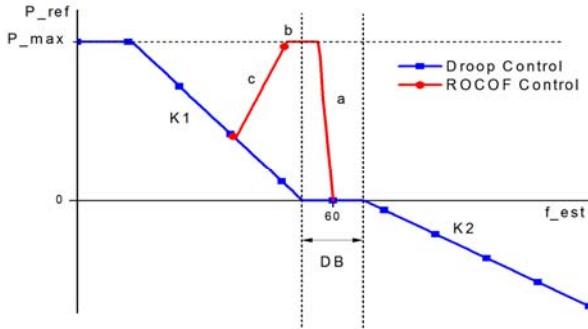

Fig. 6 The Battery output graph with frequency droop control and using ROCOF according to the system frequency [2]

TABLE I  
 INERTIA CONSTANTS OF EACH GENERATOR

Generators	Inertia time constants [MWs/MVA]
101 NUC - A	1.44
102 NUC - B	1.44
206 URBGEN	1.33
3011 MINE - G	0.83
Total	5.04

In Fig. 6, the battery output is increased in proportion to the magnitude of ROCOF drop (a). After that, battery output remains constant at that time while ROCOF is increased because the time is required to increase the output of the other generators. (b). After other generator's reserve power is inserted, battery output should be slowly decreased to reduce the impact to the system stability (c).

To apply ROCOF control to battery, the value of thresholds should be determined. When ROCOF is lower than the thresholds, the battery ROCOF control is operated. The threshold of ROCOF is associated with the power deviation between supply and demand. The time derivative  $\Delta f$  can be estimated as [2]:

$$\frac{d\Delta f}{dt}(t) = f_0 \frac{P_m(t) - P_e(t)}{2E_{Keq}} = f_0 \frac{\Delta P(t)}{2E_{Keq}} \quad (2)$$

where  $E_{Keq}$ [MWs] is the total kinetic energy stored at rated speed in the rotating masses of generator,  $P_m(t)$  and  $P_e(t)$ [MW] are the power generation and demand. Equation (2) is expressed in (3) [2]:

$$\frac{d\Delta f}{dt}(t) = f_0 \frac{\Delta P^{pu}(t)}{2H_{eq}} = f_0 \frac{\Delta P^{pu}(t)}{M_{eq}} \quad (3)$$

$H_{eq} = E_{Keq}/VA_{base}$ [MWs/MVA] and  $M_{eq}$ [s] are respectively

the equivalent inertia and mechanical start time constants of the considered power system. Total time constant of generators connected to power system is given by Table I (The base is 2500 MVA).

Initial power deviation of the ROCOF control battery operation is 30 MW (= 0.012 p.u.) because rated power of battery is determined as 30 MW. The thresholds of ROCOF control operation is determined as:

$$\frac{d\Delta f}{dt}(t) = f_0 \frac{\Delta P^{pu}(t)}{2H_{eq}} = 60 \times \frac{-0.012}{2 \times 5.0} = -0.072 \text{ Hz/s} \quad (4)$$

The output of the battery using ROCOF control increases in proportion to the magnitude of ROCOF drop and the battery output is maximum when ROCOF is -0.3 Hz/s. To confirm the ROCOF control result, the simulation is conducted. The system load is increased as 20 MW after 30 seconds from the start of simulation. It is to check the battery with ROCOF control operation when the ROCOF is over the threshold. Then, the battery output with the ROCOF control is equal to frequency droop control.

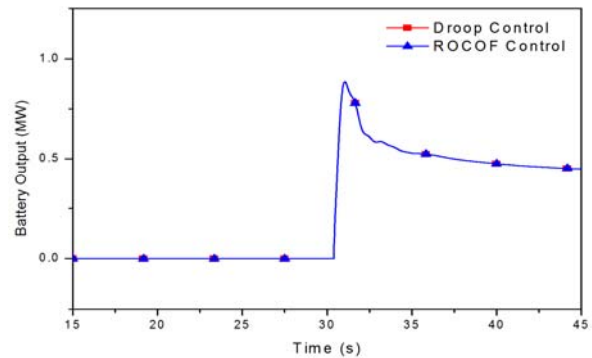

Fig. 7 The Battery output comparison according to increase the system load (20 MW)

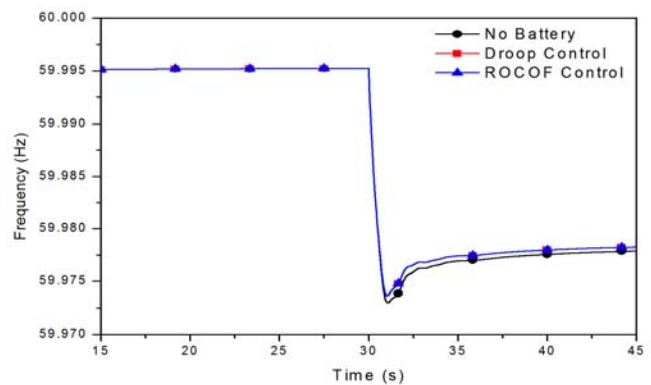

Fig. 8 The system frequency comparison according to increase the system load (20 MW)

The system load is increased by 30 MW after 60 seconds from the start of simulation. It is to confirm operation of the battery using ROCOF control when the ROCOF drops slightly below the threshold. Then, the output of battery using ROCOF

control improves the system frequency a little compared with the frequency droop control.

The system load is increased as 5% after 90 seconds simulation begins. It is to check how much battery with ROCOF control output contributes to the system stability improvement when the system load is rapidly increased. In this case, the system frequency can be considerably improved because the power deviation is more quickly compensated by the battery with the ROCOF control than only the frequency droop control.

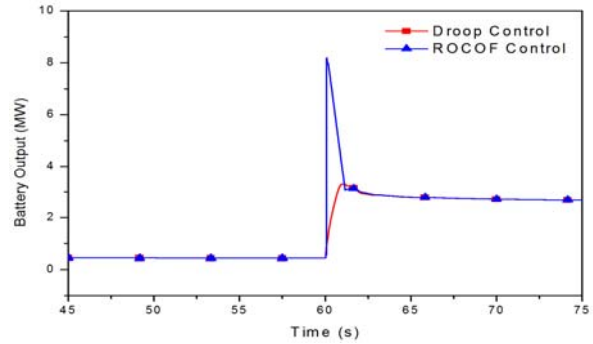

Fig. 9 The battery output comparison according to increase the system load (30 MW)

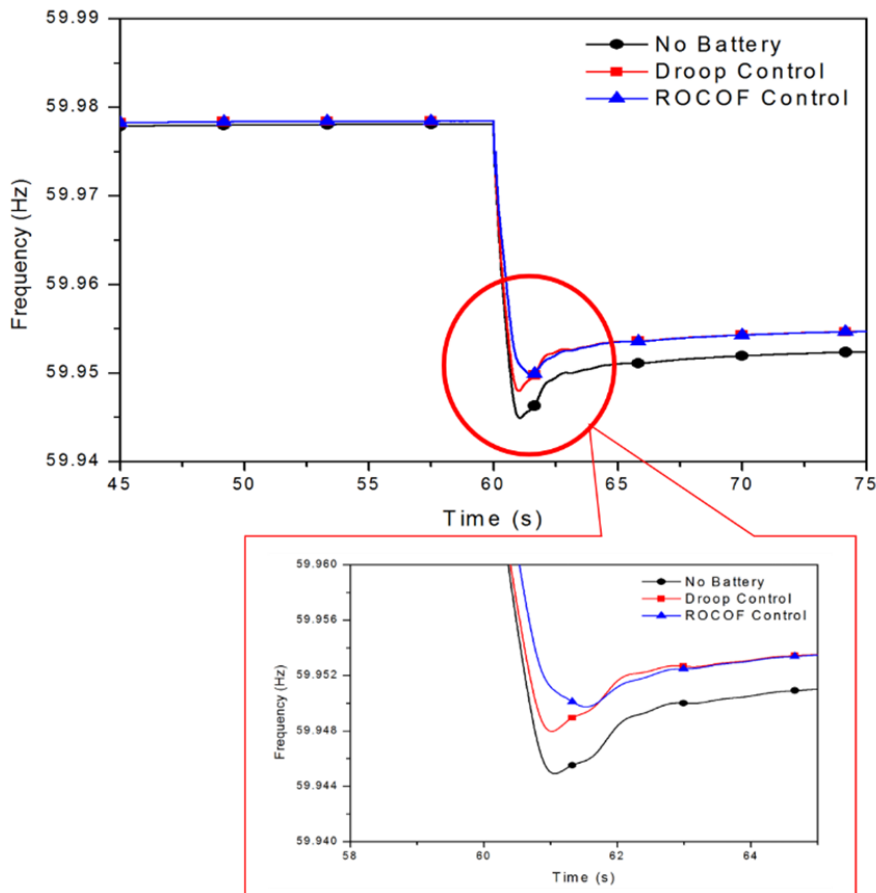

Fig. 10 The system frequency comparison according to increase the system load (30 MW)

#### IV. CONCLUSION

To improve the system stability, the power deviation between supply and demand is more quickly compensated by the proposed battery output control. The battery output is controlled by ROCOF control. The threshold of the ROCOF control is determined by the power deviation and the battery output is operated when the ROCOF is below the threshold. To compare the result between the frequency droop control and ROCOF control, simulations are performed to PSS/E. The wind farms and battery model are connected to the example power system provided from PSS/E. The simulations are performed

with the system load increase. As a result, the battery output with ROCOF control more quickly compensate the power deviation than the battery output with the frequency droop control, therefore, the power system can be operated more stably. In the future, we will calculate the limit capacity of wind farm and make plan how to operate the wind farm according to situation.

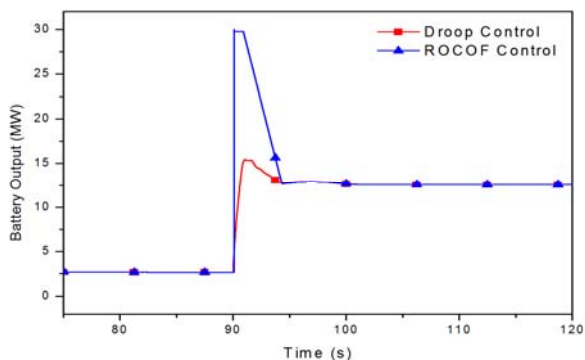

Fig. 11 The battery output comparison according to increase the system load (5%)

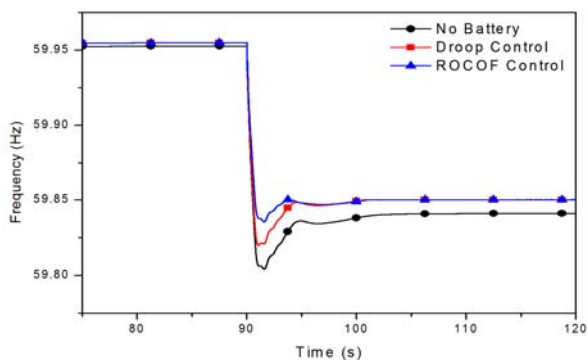

Fig. 12 The system frequency comparison according to increase the system load (5%)

#### ACKNOWLEDGMENT

This research was supported in part by the Human Resources Program in Energy Technology of the Korea Institute of Energy Technology Evaluation and Planning (KETEP), granted financial resource from the Ministry of Trade, Industry & Energy, Republic of Korea (No. 20154030200770) This research was also supported in part by Basic Science Research Program through the National Research Foundation of Korea (NRF) funded by the Ministry of Education (No. NRF-2013R1A1A2062924).

#### REFERENCES

- [1] Wei Wang, Chengxiang Mao, Jiming Lu and Dan Wang, "An Energy Storage System Sizing Method for Wind Power Integration", *Energies* 2013, 6(7), 3392-3404.
- [2] Gauthier Delille, Bruno Francois and Gilles Malarange, "Dynamic Frequency Control Support: a Virtual Inertia Provided by Distributed Energy Storage to Isolated Power Systems", *2010 IEEE PES Innovative Smart Grid Technologies Conference Europe*, in Gothenburg, Sweden, Oct 11-13, 2010.
- [3] Reliability Standards for the Bulk Electric Systems of North America, BAL-001-TRE-1, R6, updated Nov 5, 2014.
- [4] PSS/E Model Library, Chapter1 – Generator Model Data Sheets CBEST, Revised June 2009, pp 12-13.
- [5] PSS/E Program Application Guide: Volume2, Chapter23 – Elementary Block for Handling Transfer Functions in Dynamic Model, Revised October 2010.

**Dae-Hee Son** (S'13) received the B.S. degrees from Myongji University, Korea in 2013. Currently, he is a Ph.D candidate with Myongji University,

Yongin, South Korea. His research interests are the protection, control and automation of power systems.

**Soon-Ryul Nam** (S'96, M'02) received the B.S., M.S., Ph.D. degrees from Seoul National University, Korea in 1996, 1998 and 2002, respectively. Currently, he is working as a professor at Myongji University, Yongin, South Korea. His research interests are the protection, control, and automation of power systems.