

Optimization of the Control Scheme for Human Extremity Exoskeleton

Yang Li, Xiaorong Guan, Cheng Xu

Abstract—In order to design a suitable control scheme for human extremity exoskeleton, the interaction force control scheme with traditional PI controller was presented, and the simulation study of the electromechanical system of the human extremity exoskeleton was carried out by using a MATLAB/Simulink module. By analyzing the simulation calculation results, it was shown that the traditional PI controller is not very suitable for every movement speed of human body. So, at last the fuzzy self-adaptive PI controller was presented to solve this problem. Eventually, the superiority and feasibility of the fuzzy self-adaptive PI controller was proved by the simulation results and experimental results.

Keywords—Human extremity exoskeleton, interaction force control scheme, simulation study, fuzzy self-adaptive pi controller, man-machine coordinated walking, bear payload.

I. INTRODUCTION

HUMAN extremity exoskeleton is a kind of wearable intelligent robot [1] that has capability of carrying a payload and can supplement human intelligence with the strength. It is usually used for the soldiers to bear heavy payload when marching [2], so it can reduce the burden of the pilot in real time. Besides, it is capable of transporting heavy materials over rough terrain or up staircases.

At present, the research of human extremity exoskeleton is very hot in the global scope. The earlier lower extremity exoskeleton developed by University of Berkeley called BLEEX [3], [4], and the BLEEX has seven revolute degrees of freedom (DOF) per leg and four of them are powered by linear hydraulic actuators. Kazerooni et al. [5] proposed the sensitivity amplification control method (belong to the position control method) for the BLEEX that can increase the closed loop system sensitivity to its pilot's forces and torques without any measurement from the pilot. But, the control method has little robustness to parameter variations and therefore requires a relatively good dynamic model of the system. The exoskeleton developed by Kawabata et al. [6] of Tsukuba University called HAL, and HAL produces torque corresponding to the muscle contraction torque by referring to the myoelectricity that is biological information to control the operator's muscles. For each half, left and right, joints of the lower half part of the exoskeleton are achieved by three single-axis revolute joints. The lower extremity exoskeleton developed by Low et al. [7] of Singapore Nanyang Technological University (NTU), which uses the Zero Moment Point (ZMP) control strategy, can offer some

guidance for the research of the stability of lower extremity exoskeleton.

The position control method, trajectory planning, and ZMP stability criterion are all usually used in the research of traditional robot [8]. However, years of research and development experience of human extremity exoskeleton show that those traditional methods will cause poor man-machine interaction. Although they can barely achieve the synchronous walk of human extremity exoskeleton with human body, but the walking posture will not become very natural. So, the interaction force control scheme based on the current control loop of motor was proposed in our previous works. And in this paper, the fuzzy self-adaptive controller was proposed to optimize the traditional PI controller of the interaction force control scheme.

II. PREVIOUS WORK

In recent years, force control method is increasingly applied to the control scheme of humanoid robot [9]. So, in our previous works, the force control method was applied to our control scheme of human extremity exoskeleton, and the human body was regarded as a work environment of the human extremity exoskeleton. The target is to keep the interaction forces between the human extremity exoskeleton and the human body environment small, then the good man-machine coordinated walking will be realized. Finally, the rationality and feasibility of the control scheme was verified based on the simulation result. In addition, the upper extremity exoskeleton experiment was conducted, and it arrived at the same conclusions with the simulation study [10].

A. Structure Model and Control Model

The 3D model of the designed lower extremity exoskeleton is shown in Fig. 1. Pull-pressure sensors are added to shanks, thighs, and trunk of the lower extremity exoskeleton to detect the interaction forces as well as to bundle the lower extremity exoskeleton with human body. The lower extremity exoskeleton is just used to assist human body bearing heavy payload when working, the human body still has to provide some power for the movement of payload.

Since the motor controller is set to work in the current control loop, the motor torque can be controlled directly while the motor speed would be in a passive state.

After the interaction forces are detected by the pull-pressure sensors, the sensor signals will be processed and amplified by the PI controller. And then the processed and amplified signals will be used to directly control the motor torque. The block diagram of interaction force control scheme is shown in Fig. 2

Yang Li is with the Nanjing University of Science and Technology, China (e-mail: 562339471@qq.com).



Fig. 1 3D model of lower extremity exoskeleton

sensors. And then the lower extremity exoskeleton will be controlled to obey the movement of human body by the PI controller, so the interaction forces will have a tendency to become smaller. Thus, the good man-machine coordinated walking will be achieved.

B. Simulation Model and Experimental Scheme

For one single leg of lower extremity exoskeleton, it can be distinguished as two modes: the support leg and the swinging leg. They both can be seemed as three connecting rod models, and the support leg was chosen for simulating here. The MATLAB/Simulink simulation model (as shown in Fig. 3) can be established according to the overall model of the electromechanical system based on the mathematical modeling works.

Obviously, the most joints of human extremity exoskeleton need to be driven by motors in order to achieve the best power support effect. However, if the purpose is to verify the rationality and feasibility of the interaction force control scheme and the simulation results, the simple and convenient upper extremity exoskeleton experimental scheme (as shown in Fig. 4) can achieve the same results.

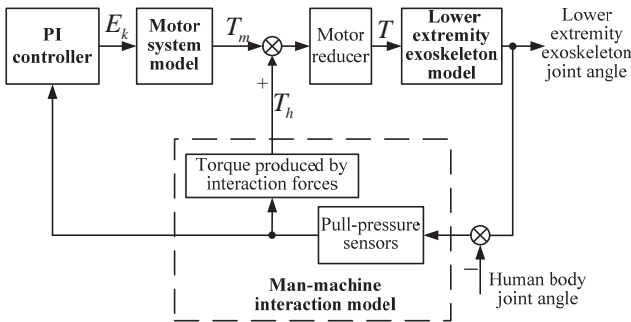

Fig. 2 Block diagram of interaction force control scheme

When the movement of lower extremity exoskeleton is not completely consistent with the human body, the interaction forces will necessarily be detected by the pull-pressure

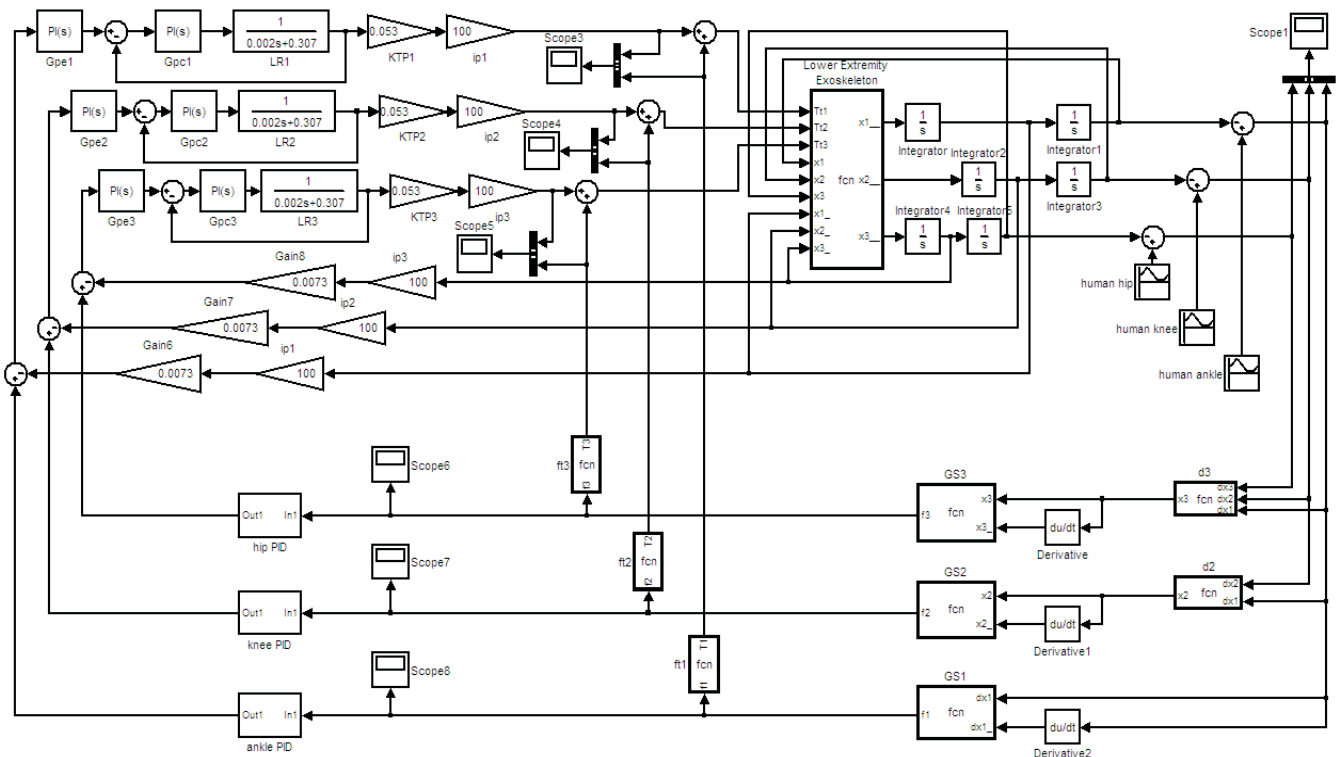

Fig. 3 MATLAB/Simulink simulation model

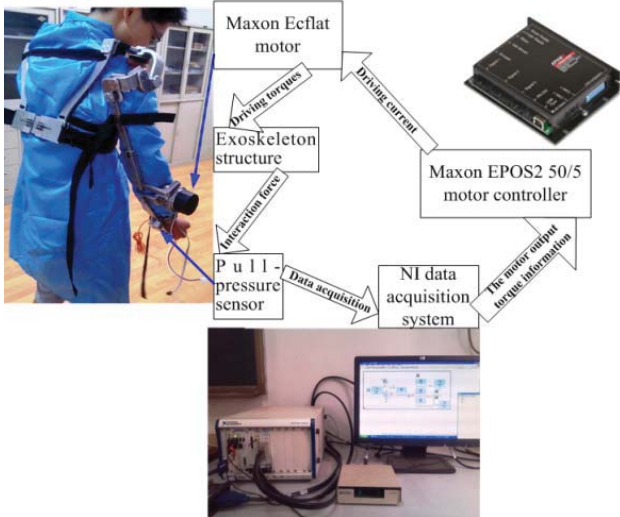

Fig. 4 Upper extremity exoskeleton experimental scheme

III. PROBLEM PRESENTATION

In our previous simulations and experiments, the rationality and feasibility of the interaction force control scheme for the human extremity exoskeleton was well verified. However, it can be seen from the following analysis that the PID controller parameters are just suitable for the simulated and experiment condition, they are not very suitable for every movement speed of human body. So, it is very necessary to seek more superior control algorithm to optimize the PID controller, and the target is to improve the adaptability and anti-interference performance of the system.

Simulating in the condition of bearing 15 kg payload (the trunk connecting rod weighs 15.5 kg), the obtained driving torques for lower extremity exoskeleton joints are shown in Figs. 5-8.

A. Driving Torque

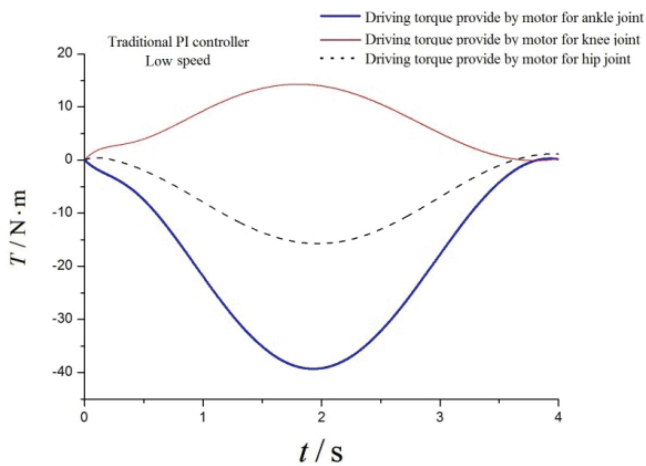

Fig. 5 Driving torques at low speed by motor

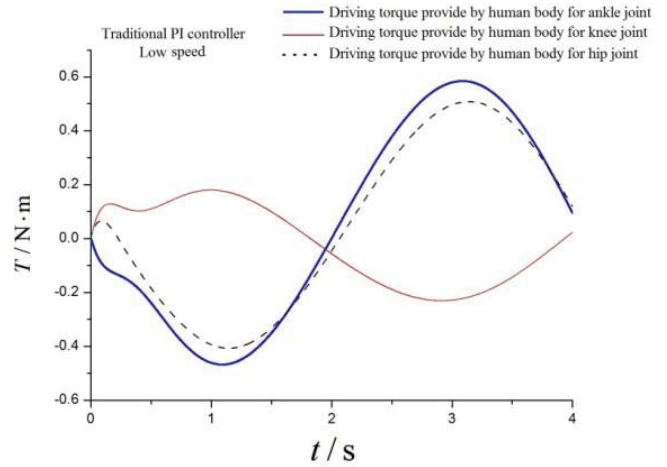

Fig. 6 Driving torques at low speed by human body

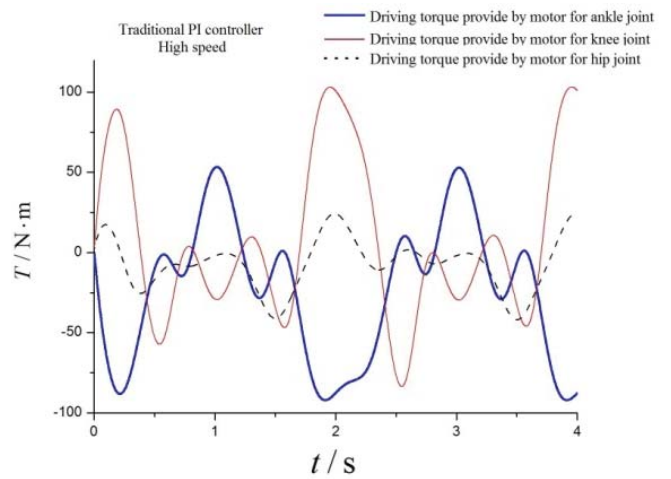

Fig. 7 Driving torques at high speed by motor

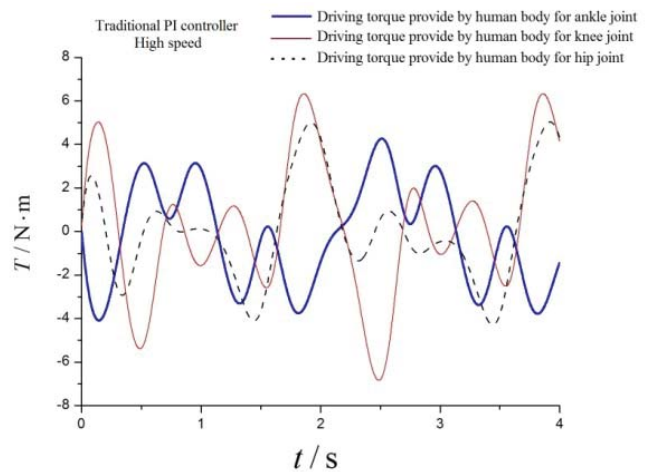

Fig. 8 Driving torques at high speed by human body

It can be remarked from Figs.5-8 that the driving torques provided by motors are more than 10 times of that provided by human body. It means that most of the torques for lower extremity exoskeleton joints to bear heavy payload were provided by motors. So, it proves that the interaction force

control scheme can help human body to bear heavy payload. However, because the parameters of the PI controller are set for the low speed condition, it can be seen by comparing Fig. 4 with Fig. 6 that the human body should provide much larger driving torques at high speed than that at low speed. So, it shows that the PI controller cannot obtain very good effect at high speed.

B. Angular Deviation

The angular deviations between the lower extremity exoskeleton and the human body joints which are obtained by simulating are shown in Figs. 9 and 10.

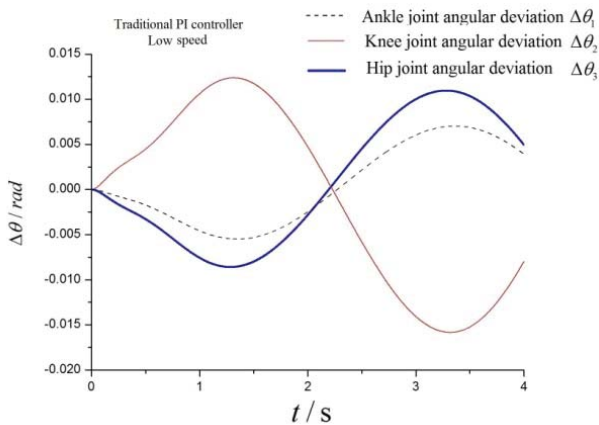

Fig. 9 Angular deviations at low speed

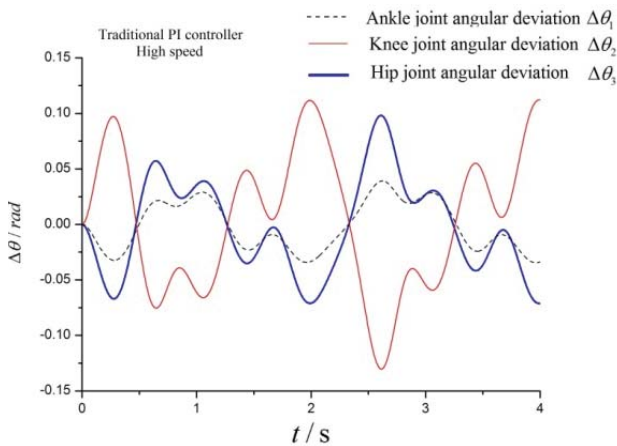

Fig. 10 Angular deviations at high speed

Because of the similarity of the three drive curves, the largest angular deviations of the three joints appear at the same time. It can be seen from Fig. 10 that all the three largest angular deviations at low speed are very small, the largest ankle joint angular deviation is $\Delta\theta_{1\text{max}} = -0.009\text{rad}$ (about 0.52°); the largest knee joint angular deviation is $\Delta\theta_{2\text{max}} = 0.012\text{rad}$ (about 0.69°); the largest hip joint angular deviation is $\Delta\theta_{3\text{max}} = -0.005\text{rad}$ (about 0.29°). So: $\Delta d_{1\text{max}} \approx -1.76\text{mm}$; $\Delta d_{2\text{max}} \approx -1.06\text{mm}$; $\Delta d_{3\text{max}} \approx 0.16\text{mm}$.

Because the parameters of the PI controller are set for the low speed condition, so the lower extremity exoskeleton can track the human body very well at low speed condition. But, the angular deviations at high speed condition become much bigger, and it is unfavorable for the system security and performance.

IV. OPTIMIZATION OF THE PI CONTROLLER

It can be seen from the above analysis that the traditional PI controller is not very suitable for every movement speed of human body. So, one kind self-adaptive PI controller should be designed to make the lower extremity exoskeleton track the human body very well at most conditions.

A. Fuzzy Self-Adaptive PI Controller Model

So, the fuzzy self-adaptive PI controller was proposed to solve this problem. The proportional-action coefficient k_p and integral-action coefficient k_i will be adjusted by the fuzzy controller based on the input signal e and input differential signal ec , so the PI controller can adapt different conditions [11]. The diagram of the fuzzy self-adaptive PI controller is shown in Fig. 11, and the fuzzy self-adaptive PI controller subsystem simulation model in Simulink is shown in Fig. 12.

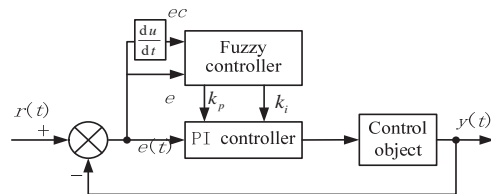

Fig. 11 Diagram of the fuzzy self-adaptive PI controller

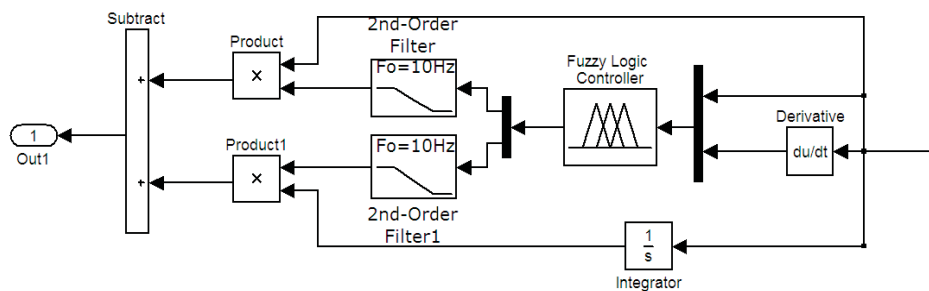

Fig. 12 Simulation model of fuzzy self-adaptive PI controller

After being processed by the low-pass filter, the outputs of fuzzy logic controller will be changed to the proportional-action coefficient k_p and integral-action coefficient k_i . And the proportional integral (PI) signal can be obtained by multiplying the input signal and input Integral signal by k_p and k_i .

B. Parameters Setting for Fuzzy Self-Adaptive PI Controller

Input signal e , input differential signal ec , proportional-action coefficient k_p and integral-action coefficient k_i are all considered to obey normal distribution. The membership functions and fuzzy rules surfaces are shown in Figs. 13-18.

V. SIMULATION VERIFICATION OF THE FUZZY SELF-ADAPTIVE PI CONTROLLER

A. Driving Torque

Only the traditional PI controller of Fig. 2 was changed to fuzzy self-adaptive PI controller, and the obtained driving torques for lower extremity exoskeleton joints by simulating are shown in Figs. 19-22.

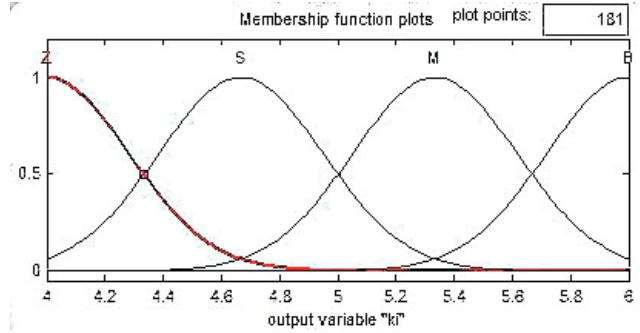

Fig. 16 Membership function of k_i

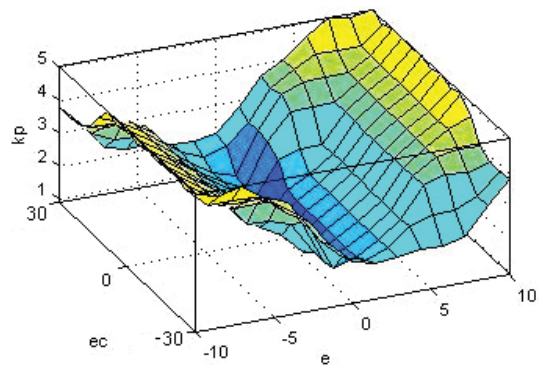

Fig. 17 Fuzzy rules surface of k_p

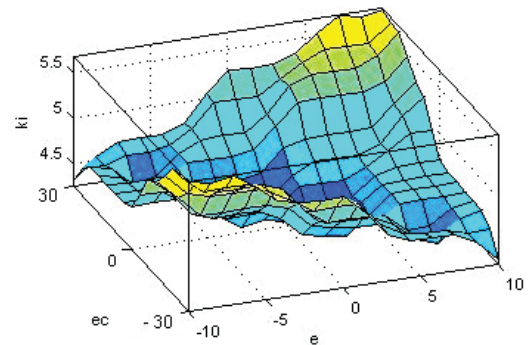

Fig. 18 Fuzzy rules surface of k_i

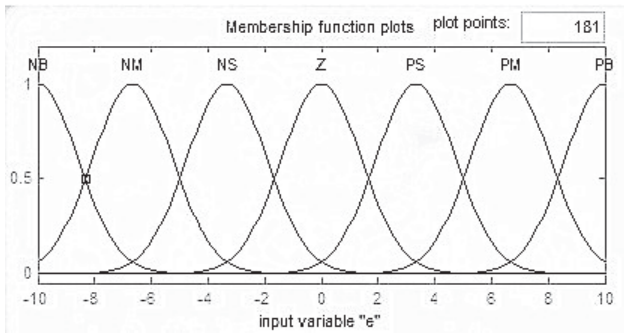

Fig. 13 Membership function of e

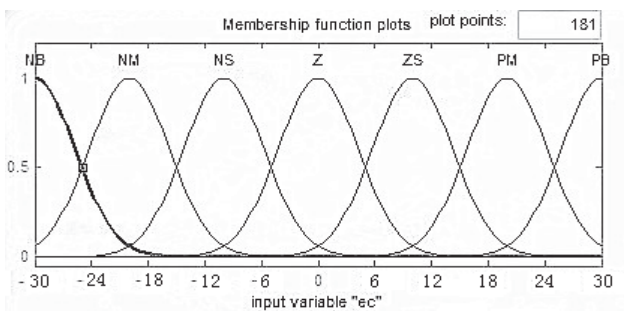

Fig. 14 Membership function of ec

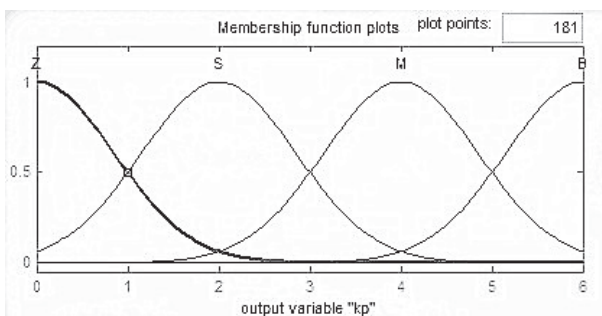

Fig. 15 Membership function of k_p

It can be seen from the figures that the driving torques by motor did not change much after the fuzzy controller was added to the traditional PI controller. However, the driving torques by human body at high speed decreased greatly after the fuzzy controller were added to the traditional PI controller, so it proves that the interaction force control scheme with fuzzy self-adaptive PI controller can achieve very good assisted effect at any condition. Besides, the total torque at high speed for lower extremity exoskeleton joints to bear heavy payload decreased slightly, so it means that the fuzzy self-adaptive PI controller has higher energy efficiency.

B. Angular Deviation

Only the traditional PI controller of Fig. 2 was changed to fuzzy self-adaptive PI controller, and the angular deviations between lower extremity exoskeleton and human body joints

which are obtained by simulating are shown in Figs. 23 and 24.

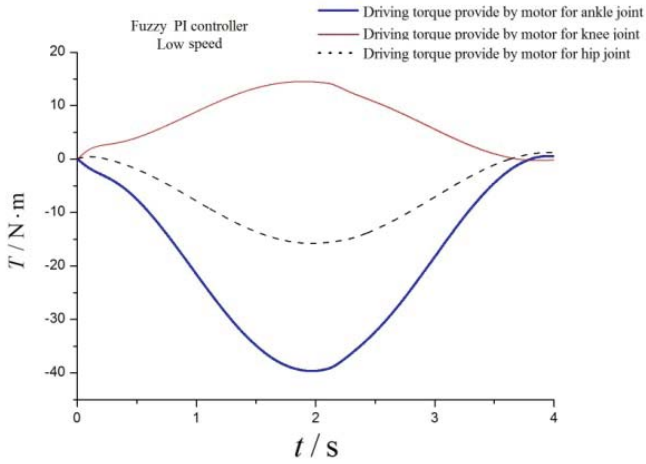

Fig. 19 Driving torques at low speed by motor

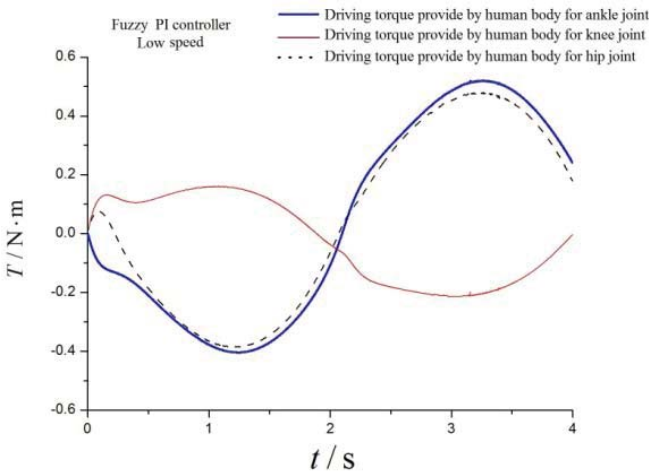

Fig. 20 Driving torques at low speed by human body

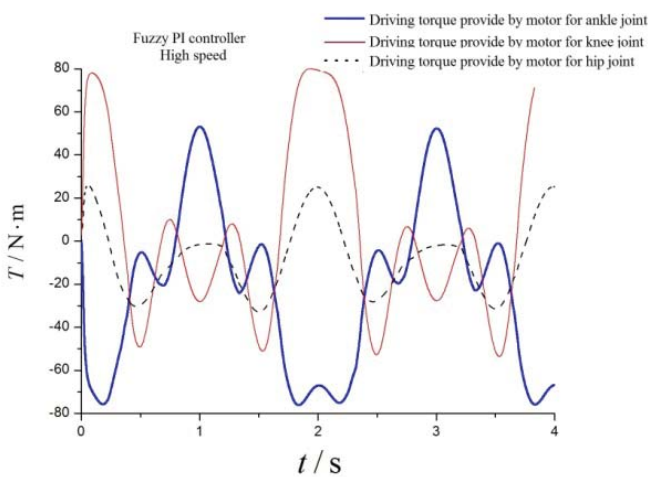

Fig. 21 Driving torques at high speed by motor

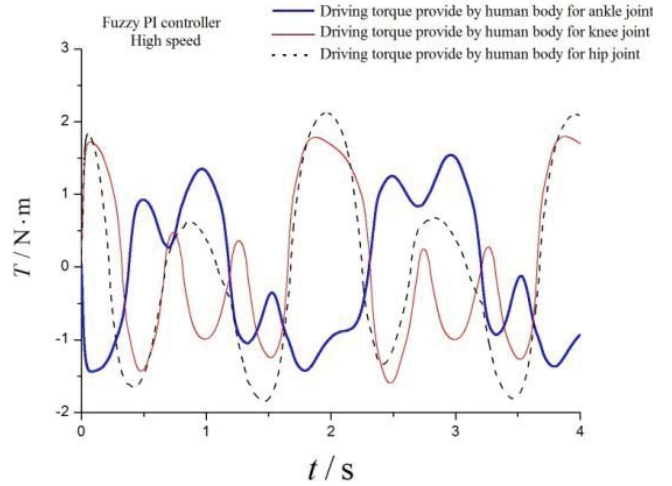

Fig. 22 Driving torques at high speed by human body

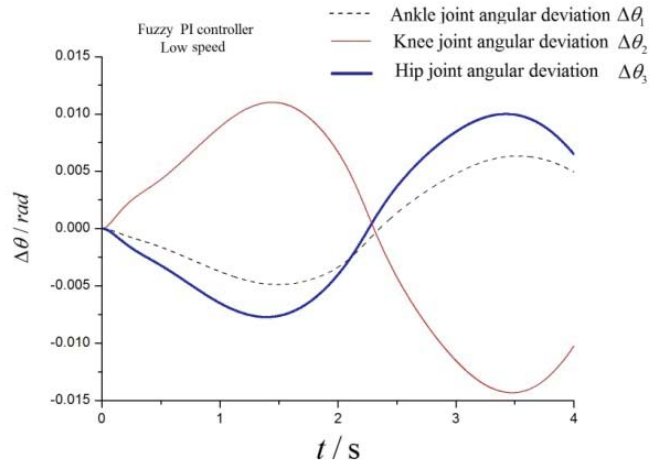

Fig. 23 Angular deviations at low speed

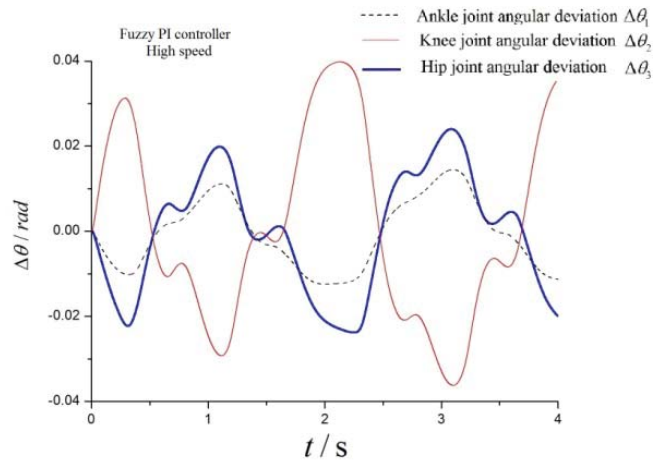

Fig. 24 Angular deviations at high speed

Based on Figs. 21 and 22, it can be seen that all the angular deviations are very small no matter at high speed condition or low speed condition. So, it can be analyzed that the lower extremity exoskeleton can track the human body very well at both high and low speed condition. Therefore, it shows that

the interaction force control scheme with fuzzy self-adaptive PI controller can achieve good man-machine coordinated walking at any condition.

VI. EXPERIMENTAL VERIFICATION OF THE FUZZY SELF-ADAPTIVE PI CONTROLLER

The simple and convenient upper extremity exoskeleton experimental scheme (as shown in Fig. 4) is still adopted here. The experimental elbow joint angular deviations are shown in Figs. 25, 26.

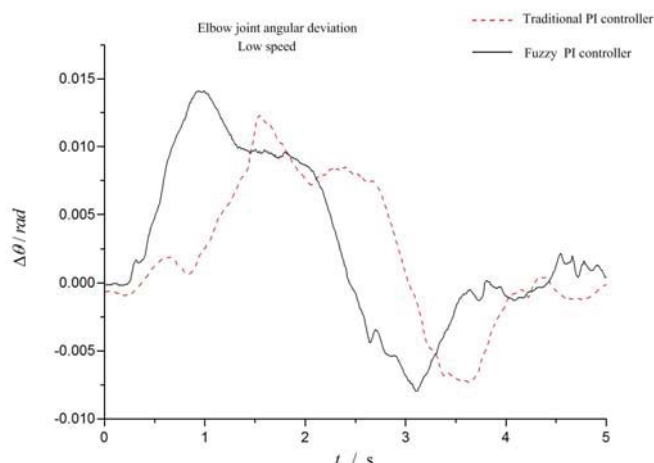

Fig. 25 Elbow joint angular deviation at low speed

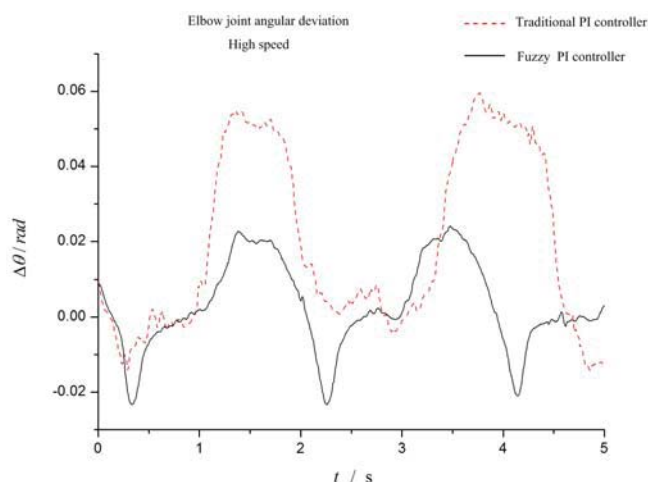

Fig. 26 Elbow joint angular deviation at high speed

It can be seen from Fig. 23 that the elbow joint angular deviation did not change much after the fuzzy controller was added to the traditional PI controller at low speed. And in contrast, it can be seen from Fig. 24 that the angular deviation greatly reduced at high speed. So, just the same as the simulation results, it proves that the interaction force control scheme with fuzzy self-adaptive PI controller can achieve good man-machine coordinated walking no matter at high speed condition or low speed condition. Moreover, from the experience of the pilot, the movement process was easily implemented when the fuzzy controller was added to the

traditional PI controller at high speed. In contrast, the movement process will become much harder for the pilot if the fuzzy controller was removed.

VII. CONCLUSION

To seek a suitable and feasible control scheme for lower extremity exoskeleton, in our previous work, the traditional PI interaction force control scheme was proposed. Then, the simulation model was established and the simulation was carried out. Based on the simulation results, the main problem is that the controller is not very suitable since every movement speed of human body was presented. So, the fuzzy self-adaptive controller was added to the traditional PI controller to solve this problem. At last, the simulation results and experimental results prove that the interaction force control scheme with fuzzy self-adaptive PI controller can achieve good man-machine coordinated walking and also can help human body to bear heavy payload at any condition. At the same time, the rationality and feasibility of the interaction force control scheme with fuzzy self-adaptive PI controller for lower extremity exoskeleton was verified.

ACKNOWLEDGMENTS

This study was supported in part by the national natural science foundation of China (NO.51575279).

REFERENCES

- [1] Zhang Jiafan, Chen Ying, Yang Canjun. Man-machine Intelligent Systems of Flexible Exoskeletons. Science press, 5-6 (2011).
- [2] Yang Zhiyong, Gu Wenjing, Zhang Jing, Gui Lihua. Force Control Theory and Method of Soldier Load Carrying Exoskeleton Suit. National defense industry press, 1-5 (2013).
- [3] A. Zoss and Kazerooni, H. Kazerooni, On the Mechanical Design of the Berkeley Lower Extremity Exoskeleton (BLEEX), Proc. of IEEE Intelligent Robots and Systems, Edmonton, Canada, 3132-3139 (2005).
- [4] A. Zoss, Kazerooni, H. Kazerooni, Andrew Chu. On the Biomechanical Design of the Berkeley Lower Extremity Exoskeleton (BLEEX), IEEE/ASME Transactions on Mechatronics, Vol.11(2), 128-138 (2006).
- [5] H. Kazerooni, Jean-Louis Racine, Lihua Huang, and Ryan Steger, On the Control of Berkeley Lower Extremity Exoskeleton (BLEEX), Proc. of IEEE International Conference on Robotics and Automation, Barcelona, Spain, 4364-4371 (2005).
- [6] Tomoyoshi Kawabata, Hozumi Satoh. Working Posture Control of Robot Suit HAL for Reducing Structural Stress. IEEE International Conference on Robotics and Biomimetics, Guilin, China, 19 -23 (2009).
- [7] K. H. Low, Xiaopeng Liu, Haoyong Yu. Development of NTU Wearable Exoskeleton System for Assistive Technologies. IEEE International Conference on Mechatronics & Automation Niagara Falls, Canada, 1099-1106 (2005).
- [8] Fu Chenglong. Section Mapping Stability Criterion and Application of the Plane Biped Robot. Beijing: tsinghua university Ph.D. Thesis (2006).
- [9] Li Zhengyi, Cao Huimin. Robot Impedance Control Method Adapting to Unknown or Changing Environment Stiffness and Damping Parameters. China Mechanical Engineering, 1581-1585 (2014).
- [10] Yang Li, Cheng Xu, Xiaorong Guan. Modeling and simulation study of electromechanically system of the human extremity exoskeleton. Journal of Vibroengineering, 551-561 (2016).
- [11] Ying Wu, Hang Jiang, Min Zou. The Research on Fuzzy PID Control of the Permanent Magnet Linear Synchronous Motor. Physics Procedia, Vol.24, 1311-1318, (2012).