

Transformer Life Enhancement Using Dynamic Switching of Second Harmonic Feature in IEDs

K. N. Dinesh Babu, P. K. Gargava

Abstract—Energization of a transformer results in sudden flow of current which is an effect of core magnetization. This current will be dominated by the presence of second harmonic, which in turn is used to segregate fault and inrush current, thus guaranteeing proper operation of the relay. This additional security in the relay sometimes obstructs or delays differential protection in a specific scenario, when the 2nd harmonic content was present during a genuine fault. This kind of scenario can result in isolation of the transformer by Buchholz and pressure release valve (PRV) protection, which is acted when fault creates more damage in transformer. Such delays involve a huge impact on the insulation failure, and chances of repairing or rectifying fault of problem at site become very dismal. Sometimes this delay can cause fire in the transformer, and this situation becomes havoc for a sub-station. Such occurrences have been observed in field also when differential relay operation was delayed by 10-15 ms by second harmonic blocking in some specific conditions. These incidences have led to the need for an alternative solution to eradicate such unwarranted delay in operation in future. Modern numerical relay, called as intelligent electronic device (IED), is embedded with advanced protection features which permit higher flexibility and better provisions for tuning of protection logic and settings. Such flexibility in transformer protection IEDs, enables incorporation of alternative methods such as dynamic switching of second harmonic feature for blocking the differential protection with additional security. The analysis and precautionary measures carried out in this case, have been simulated and discussed in this paper to ensure that similar solutions can be adopted to inhibit analogous issues in future.

Keywords—Differential protection, intelligent electronic device (IED), 2nd harmonic, inrush inhibit.

I. INTRODUCTION

DIFFERENTIAL relays are the most important protection of Extra High Voltage (EHV) transformers. When transformers are charged, it results in inrush current which consists of second harmonic current. The second harmonic inrush restraint function of transformer differential relays maintains security of the differential protection during transformer inrush events. The setting of harmonic restraint specifies mode of blocking on magnetizing inrush conditions. Modern transformers may produce small second harmonic ratios during inrush conditions due to use of high grade cold rolled grain oriented (CRGO) for transformer core. Nowadays, condition based maintenance is preferred, and periodically winding resistance measurement is also done. Winding resistance measurement causes saturation of core, and thus,

K. N. Dinesh Babu is a Sr Application Engineer, Megger, India (e-mail: dineshbabu.nagalingam@megger.com).

P. K. Gargava is an Executive Engineer MPPTCL, India (e-mail: pkgargava@hotmail.com).

second harmonic content of inrush current is further reduced. This may result in undesired tripping of the protected transformer. To avoid such tripping, the setting of 'second harmonic inhibit' threshold is reduced and then it may jeopardize dependability and speed of protection. The second harmonic inrush restraint block function affects speed of relay and becomes liable once transformer is charged because once transformer is charged, there is no use of this function.

This paper proposed that if IEDs can be programmed to disable this function after transformer is charged similarly to switch on to fault (SOTF) function of distance protection relay, then the operation time of differential protection can be reduced, and tripping will not be blocked for internal faults due to second harmonic content which is initially observed in faults in some specific cases.

It is an effort to eliminate misoperation of transformer differential relays due to low second harmonic on inrush without sacrificing protection capabilities.

II. TYPES OF INRUSH CURRENT

Inrush current can be discussed under two major categories [1], [2].

A. Energization of the Transformer

This is the distinctive event where magnetizing inrush currents are a distress. The excitation voltage on a winding is augmented from zero to full voltage, which results in saturation of the transformer core, and the saturation level is determined by the design of the transformer, system impedance, the remnant flux present in the core, and the point on the voltage wave when the transformer is energized. The current desired to source this flux may be with typical value for power transformers for two or six times the full load rating.

B. Magnetising Inrush Current during Fault Clearing

An external fault may ominously suppress the system voltage, and consequently diminish the excitation voltage of the transformer. When the fault is cleared, the excitation voltage returns to the normal system voltage level. The reappearance of voltage may force a DC offset on the flux linkages, resulting in magnetizing inrush current. The magnetizing inrush current will be less than that of energization, as there is no remnant flux in the core. The current measured by the IED will be linear due to the presence of load current, and may result in low levels of second harmonic current.

III. CHALLENGES WITH EXISTING INBUILT LOGIC OF IEDS

In existing logic of almost all IEDs, only setting of ratio of second harmonic to fundamental is available. The harmonic block restraint setting delays differential relays by 13-15 ms as per manufacturer's specifications. In most of IEDs, high set differential tripping function is available which eliminates harmonic blocking feature. But, in case of low energy internal fault harmonic restraint feature remains in operation of differential relay. The continuous presence of this feature may result in unwarranted operation under certain situations, and three such situations which occurred in Madhya Pradesh Power Transmission Corporation Limited (MPPTCL), India are explained in Section A and B.

A. Healthy Case Trip Scenario - Transformer Tripping during Charging – 132 kV S/S Ratlam- 40MVA Transformer

At 132/33 kV 40 MVA transformer was charged, but the differential relay tripped due to failure of the CT at 132 kV

side. The healthiness of the transformer was confirmed by conducting a winding resistance test. On completion of the test, the transformer winding was found healthy, and the issue in the CT was resolved and verified for charging. The transformer was charged again, and the differential relay issued a trip. On analysis of the disturbance record (DR), it was observed that the transformer was healthy, and the trip was due to improper setting on second harmonic value. The setting adopted was 20% of second harmonic whereas the transformer was consuming less than 20% of second harmonic due to which the IED failed to block the differential function. The low harmonic value was due to the winding resistance test which caused partial saturation of core. Fig. 1 shows the presence of low current harmonic in R phase. As the differential element has been picked up in all the three phases, the R phase differential was triggered due to low second harmonic function.

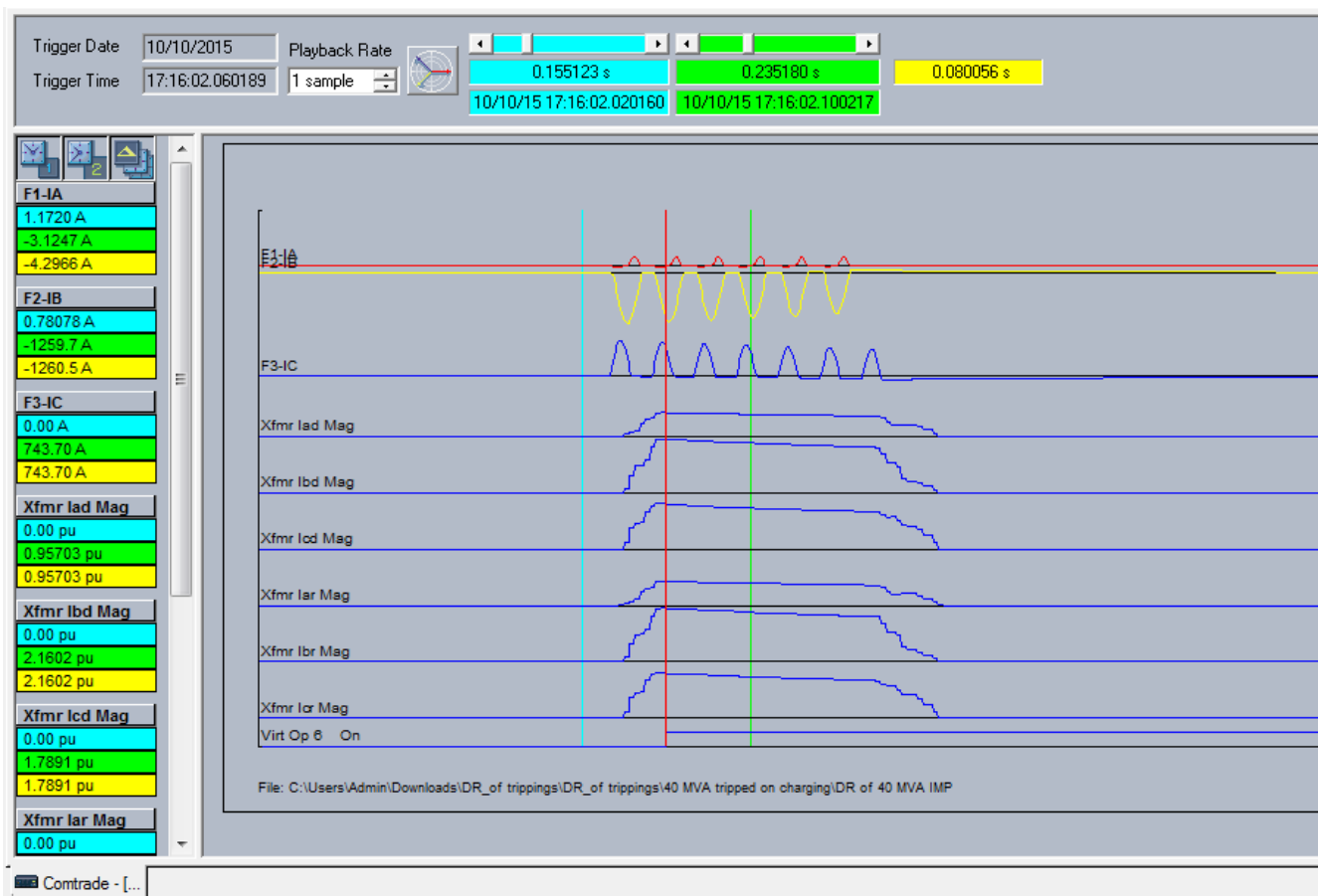

Fig. 1 Ratlam 40MVA Transformer – Tripped on healthy condition

A. Faulty Case Delayed Tripping Scenario - Transformer Bushing Failed and Was on Fire - Nagda 400 kV S/S-315MVA Transformer

A 400/220 kV 315 MVA transformer tripped due to bushing failure and subsequently was on fire. Fig. 2 shows the DR where it can be observed that the differential element was delayed by 16 ms due to second harmonic block feature when

fault occurred.

B. Faulty Case No-Trip Scenario - Differential Blocked Due to Second Harmonic - Bina 400 kV S/S-315MVA Transformer

A 315 MVA Transformer was charged at Bina 400 kV Substation. During charging, some internal fault developed in the tertiary winding of transformer. The IED failed to trip on

differential as second harmonic function has blocked the operation and thus the fault was developed and later cleared by Buchholz relay and PRV. Fig. 3 shows the scenario in DR where the fault was persisting before the DR was triggered.

The 86 A trip relay which has triggered the DR was actuated by Buchholz. In addition, the DR shows that all the differential elements were high, but second harmonic blocked triggering.

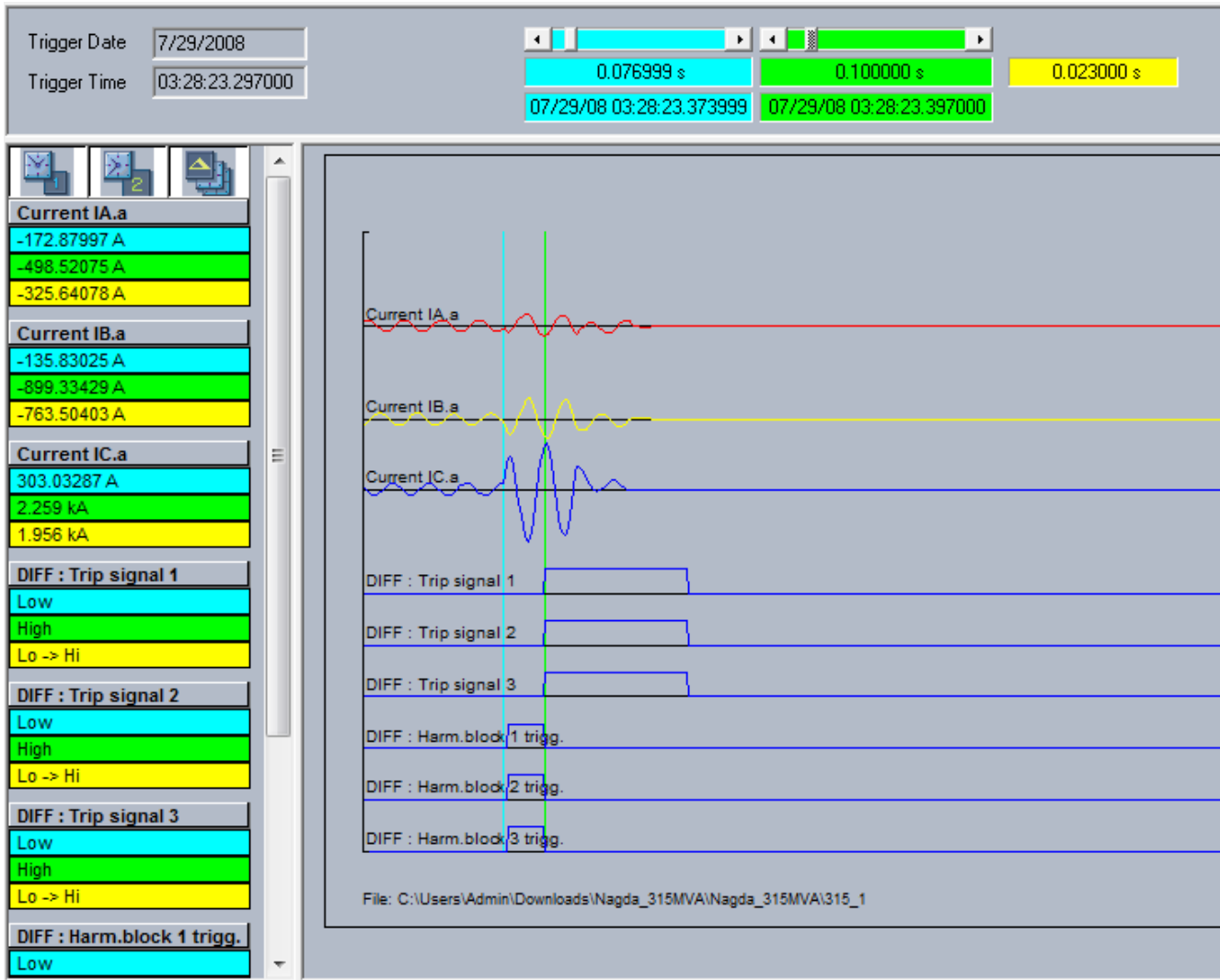

Fig. 2 Nagda 315MVA Transformer – Delayed trip for faulted condition

The internal logic in IEDs has failed to provide the security in the Ratlam, Nagda, and Bina case. In order to handle these cases, a custom logic was developed, and the performance was verified for the aforementioned cases which are discussed in Section IV.

IV. PROPOSED LOGIC

Tripping of transformer due to low second harmonic in one phase can be avoided by using cross block feature of the IED. In some IEDs, this option is available and it can be programmed by flex logic. The restricted earth fault (REF) protection is free from harmonic restraint and if REF protection is provided, it can issue high speed tripping. On the other hand, REF will be operated only if zero sequence current is produced. This paper proposes the logic which will

keep harmonic restraint function active only during charging after a certain time (when inrush current becomes very low) this function will be disabled to increase speed of tripping. The function will be disabled after certain time of charging and will be enabled again by sensing breaker contact or minimum current setting to handle inrush current. The external fault condition sometimes may cause inrush current after fault is cleared and voltage is recovered as explained in Section II. However, bias setting and pickup setting will take care of such phenomenon as transformer will be on load. To check stability against external fault condition proposed logic which is as under has been implemented in a 40 MVA transformer differential relay. The logic will operate differential protection element which is free from harmonic restraint and it will also generate event as events are not dependent on this logic. The

proposed logic is shown in Fig. 4 which was created using UR logic is available in GE-T60 Manual [4].
 setup software of GE [3]. Detailed explanation on creating the

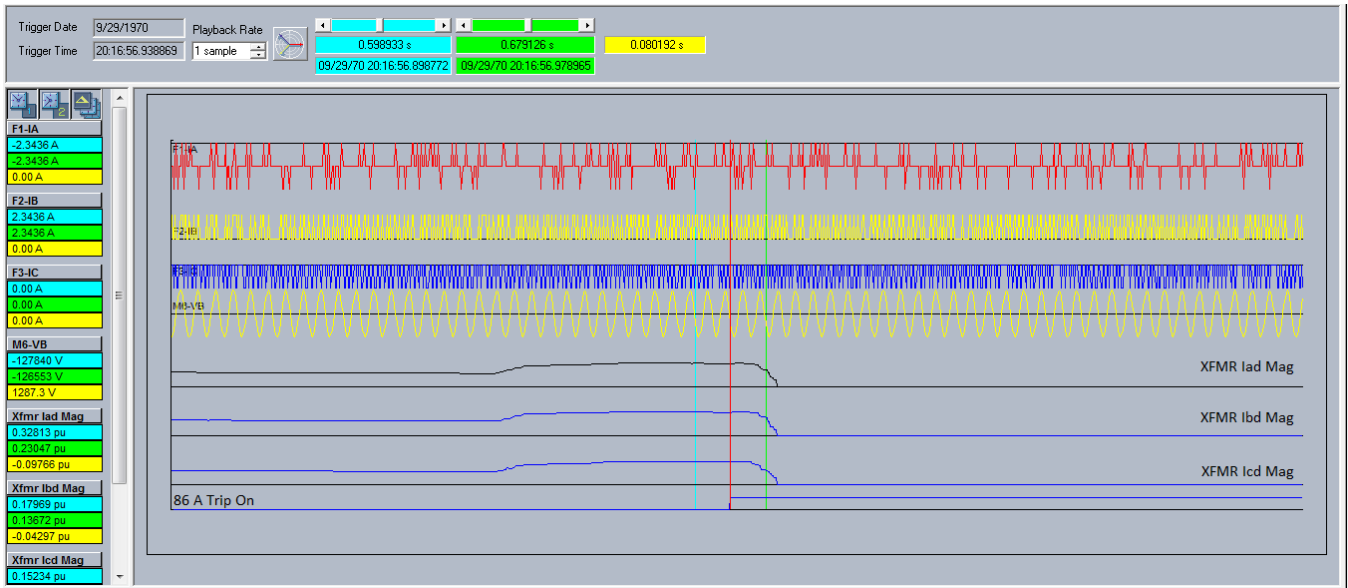

Fig. 3 Bina 315MVA Transformer – No trip for faulted condition

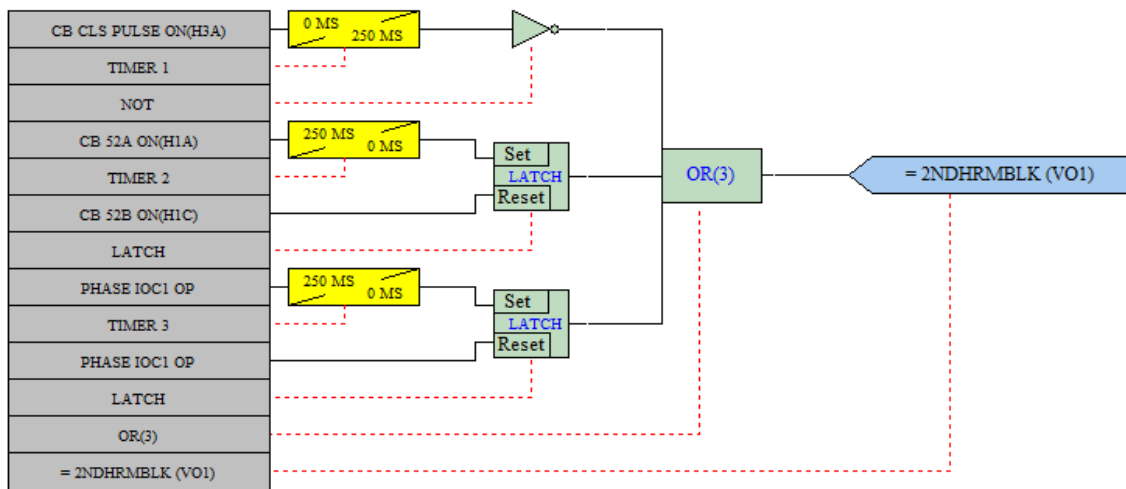

Fig. 4 Proposed logic for dynamic switching of second harmonic

The close pulse issued to the circuit breaker (CB) by the use of a TNC switch is wired to the contact input number H3A, CB open/close feedback (52A/52B) are wired to contact input number H1A, H1C of the IED as shown in Fig. 4. The CB close pulse will be passed through a timer which will hold the signal for pre-set time duration. This duration can be tuned to adapt to the inrush interval of the transformer. The pulse received is inverted and used to pick a virtual output 1 (VO). In case of transformer restrike on external fault scenario, the logic will be secured by the use of CB feedback or current supervision settings using latch logic. The CB feedback contact 52B will be high when the CB is in open position, and 52A will be high when the CB is closed. When the transformer is tripped, 52B will be high, thus resetting the latch which in turn will bring the second harmonic feature into

the logic. When the CB is closed, 52A will be high after 250 ms, and this function will set the latch, thus blocking the second harmonic. An additional security is added using current supervision, to handle situations when the CB feedback fails. This facility can also be used in places where CB feedback cannot be wired. The phase IOC1 OP setting is tuned to pick up for minimum supervision current which will bring the second harmonic function into the logic. After 250 ms, the phase IOC1 will continue to be high which will set the latch. Though the set and reset are high, the SR flip flop is configured for set dominant type, and hence, it will pick up, thus successfully eliminating the second harmonic after charging.

Fig. 5 shows the second harmonic configuration where the signal VO1 is used to block this function after the set time

delay of 250 ms. Thus, the second harmonic block function will be in picture only during the initial charging phase of the

transformer. The implemented logic was verified by suitable test procedures discussed in the next section.

PARAMETER	FLEXELEMENTS 1
Function	Enabled
Name	2ndHar
InputPlus	SRC1 Ia Harm[2]
InputMinus	OFF
InputMode	SIGNED
Compare Mode	LEVEL
Direction Type	OVER
Pickup	0.200 pu
Hysteresis	3.0 %
DeltaTUnits	Milliseconds
DeltaT	20
Pickup Delay	0.000 s
Reset Delay	0.000 s
Block	2ndHrmBLK On (VO1)
Target	Self-reset
Events	Disabled

Fig. 5 Second Harmonic configuration in the IED

V. RESULTS & DISCUSSION

The faulted oscillograph file was played back in using SMRT secondary injection test kit of Megger [5]. This software has the capability to replay the fault file and reproduce the same scenario in secondary value in the IED. The logic discussed in the previous section was implemented in an IED and the fault file was played again to verify the performance. The observations are shown in Table I.

TABLE I
 SUMMARY OF RESULTS BEFORE & AFTER IMPLEMENTING THE PROPOSED LOGIC

Case	Scenario	Without Logic	With Logic
1	Healthy Transformer charging	Trip	Trip
2	Faulty Transformer	Delayed Trip	Trip without delay
3	Faulty Transformer	No Trip	Trip

The first case is a healthy transformer charging where there was no impact of the logic as this scenario is related to tuning of the second harmonic setting or cross blocking phenomena of IEDs. Though this situation is an unwanted trip, the life of the transformer nor the system is not affected and hence this case can be ignored. The other two cases are handled in the proposed logic and hence the deteriorating of insulation is reduced due to accelerated / proper trip for faulted condition.

VI. CONCLUSION

The life of transformer is greatly affected by numbers of faults fed by transformer and duration of fault current. The level of fault current is always high enough. It depends upon the voltage which has been short - circuited and upon the impedance of the circuit up to the fault point. The copper loss of the fault feeding transformer is abruptly increased. This increasing copper loss causes internal heating in the transformer. Large fault current also produces severe mechanical stresses in the transformer. The EHV transformers used in transmission system are feeding 33 KV lines of

DISCOM. Some of these lines are feeding rural areas. The length of lines also varies from short to 15-20 km. The occurrences of faults in 33 KV lines are common and frequent. Due to increase in nos. of EHV lines and Sub-stations fault level of 132/33 KV Sub-stations have also increased. By reducing fault current time, we can not only avoid failure or damage of transformer, but also, we can increase life of transformer. The introduction of concept of second harmonic dynamic switching is one of the important steps in "LIFE MANAGEMENT OF TRANSFORMER".

REFERENCES

- [1] C. E. Lin, C. L. Cheng, C. L. Huang, J. C. Yeh, "Investigation of Magnetizing Inrush Current in Transformers Part II Harmonic Analysis", IEEE Transactions on Power Delivery, Vol. 8, No. 1, January, 1993, pp. 255-263.
- [2] www.ctrical.blogspot.in/2016/10/Sympathetic-Inrush-current.html (Accessed on 29/10/2016).
- [3] www.gegridsolutions.com, Enervista UR setup version, Version 7.32 (Accessed on 29/10/2016).
- [4] GET60 Transformer Protection System - Manual P/N: 1601-0090-AA1 (GEK-119568).
- [5] www.megger.com, SMRT Test kit for comtrade file playback (Accessed on 29/10/2016).



PK Gargava has a bachelor of electrical engineering from Government Engineering College Ujjain (M.P.). He is MBA and Certified Energy Auditor. He is currently working for M.P. Power Transmission Company Limited as an Executive Engineer (Testing). He has more than 27 years of vast experience of operation, maintenance, testing and commissioning of EHV equipments up to 400 KV. He has developed expertise in state of art numerical relays testing technologies and also well acquainted with commissioning and testing of different make of relays. He has thorough experience of inspections of electrical equipments (transformers, circuit breakers, relays, etc) at the works of manufacturers. phone: +91 9425804959, e-mail: pkgargava@hotmail.com



K N Dinesh Babu is a professional power system protection engineer in India with extensive experience in HV / EHV sub stations and industries. His work background includes experience in working for Alstom, ABB, GE and Megger in various roles like testing; commissioning; design and

application engineering. A major portion of this experience has been in the area of protective relaying with a major focus on the application and coordination of protective facilities on electrical power systems. His experience includes the development of protection philosophies, implementation of new technologies in the field; control logic requirements for protective systems; development of specifications for protective relay settings; and analysis of disturbances and faults in electric power systems. He has also experience in training protection engineers, field engineers and O&M engineers on IEDs, SCADA, power system protection and synchrophasors for major utilities and industries in India and Abroad.

He holds a doctorate in electrical engineering and is a DFSS certified six sigma green belt. He is a senior member of IEEE. His areas of contribution are electric traction, power system protection and renewable energy utilization and have published several articles in international journals and conferences. phone: +91 9790920721, e-mail: dineshbabu.nagalingam@megger.com