

# Development of a Remote Testing System for Performance of Gas Leakage Detectors

Gyoutae Park, Woosuk Kim, Sangguk Ahn, Seungmo Kim, Minjun Kim, Jinhan Lee, Youngdo Jo, Jongsam Moon, Hiesik Kim

**Abstract**—In this research, we designed a remote system to test parameters of gas detectors such as gas concentration and initial response time. This testing system is available to measure two gas instruments simultaneously. First of all, we assembled an experimental jig with a square structure. Those parts are included with a glass flask, two high-quality cameras, and two Ethernet modems for transmitting data. This remote gas detector testing system extracts numerals from videos with continually various gas concentrations while LCDs show photographs from cameras. Extracted numeral data are received to a laptop computer through Ethernet modem. And then, the numerical data with gas concentrations and the measured initial response speeds are recorded and graphed. Our remote testing system will be diversely applied on gas detector's test and will be certificated in domestic and international countries.

**Keywords**—Gas leakage detector, inspection instrument, extracting numerals, concentration.

## I. INTRODUCTION

A number of consumed quantities of gases are increasing annually in the proportion of growth of gaseous facilities and plants with by liquefied natural gas (LNG) and liquefied petroleum gas (LPG) and gas industrial complexes utilized with hydrogen sulfide, chlorines, ammonias, and toxic substances [1]. In industrial areas, prevention against accidents of gas leakage and explosion is indispensable for gas safety [2]. For example, on February 27 2016, an accident on LPG gas leakage and explosion happened at Jecheon city, Korea. That accident has brought damage to 40 billion properties [3]. Prevention and safety management against gas risks also are the requisites for industrial fields to be used by toxic and combustible gases [4]. To protect multifarious risks and accidents, Korea Gas Safety Corporation (KGS) has been achieving the first construction completion inspection and regular check on the joints, valves, and pipelines at gaseous industrial facilities. In the safety management and inspection process, gas leakage instruments have to prepare rapidly the initial response time, excellent accuracy, and strong durability [5], [6]. This is because we designed remote testing system for experimenting and

G. Park is with the Institute of Gas Safety R&D, Korea Gas Safety Corporation, Chungbuk-do, 27738 Korea (phone: +82-43-750-1443; e-mail: gtparkgs@kgs.or.kr).

S. Ahn is chief of the RFengine Co., Ltd., Chungju-si, Korea (e-mail: sgahn@rfengine.com).

W. Kim, S. Kim, M. Kim, J. Lee, Y. Jo and J. Moon are with Korea Gas Safety Corporation, Chungbuk-do, Korea. J. Moon is the Chief of Institute of Gas Safety R&D, KGS (e-mail: mjs86@kgs.or.kr).

H. Kim is a professor with Electrical and Computer Engineering, University of Seoul, Korea (e-mail: drhskim@uos.ac.kr).

certificating gas leakage detectors. The measuring accuracy and initial response time are items of tests in a variety of combustible and toxic gas leakage detectors and instrument. At first, portable combustible gas leakage detectors are target on test and certification. In the next chapter, manufacture of testing device, test method, and process are described.

## II. MAIN

### A. Manufacture of Remote Concentration Measurement Jig

Fig. 1 shows jigs to test gas concentration and initial response time of gas leakage detectors. The jigs consist of four columns and sides, a glass flask, and fixed cross stand.

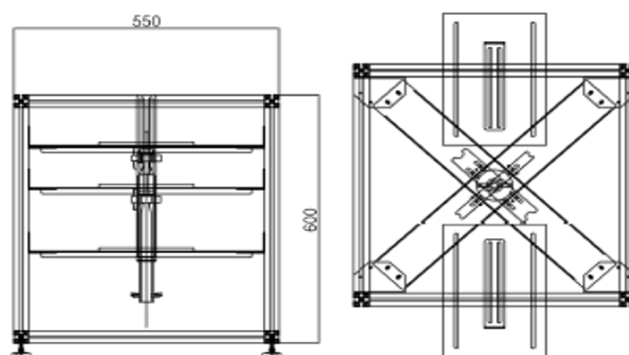

Fig. 1 Appearances of measurement jig

As shown in Fig. 2, jigs for measuring and testing gas leakage detectors are additionally included with several devices and apparatus such as seven types of standard gases and vessels, pressure controlled valves to control flow rates, an apparatus to input gases, equipment to prop two gas leakage detectors, two high quality camera modules, and two Ethernet communication modules for sending video files. Fig. 3 shows devices to transmit video (MPEG) files to notebook PC with MAC address of 48 bits through local area network. Video files are filmed by high-quality cameras and sent to notebook PC at a rate of 100 Mbps.

### B. Development of System to Measure Gas Concentration and Initial Response Time

As it is mentioned above, Fig. 4 shows a whole configuration of remote testing system for gas leakage detectors. Test and comparison of two gas detectors are available. Here, Korea and USA products are tested. Fig. 5 shows comparatively measuring test of the Korea and Japan detectors. Fig. 6 is the

view of a remote measuring system for performance test of gas leakage detectors.

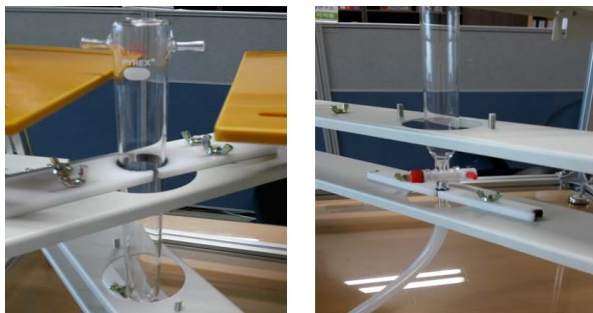

Fig. 2 A glass flask for measuring gas concentration

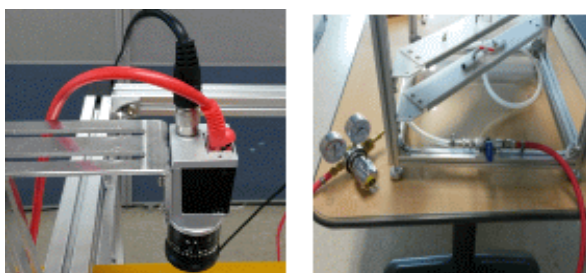

Fig. 3 The jig equipped with a camera and a flow controlling device

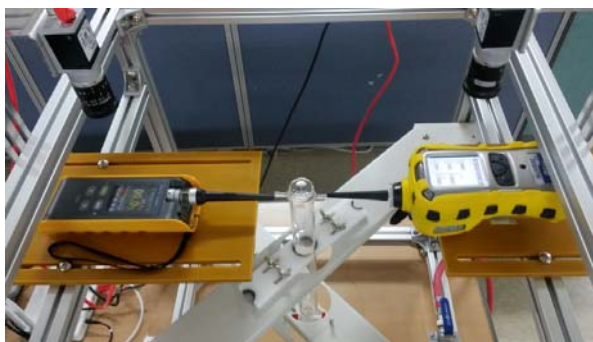

Fig. 4 A remote testing devices for measuring gas concentration (left: Korea' detector, right side: USA's detector)

Structures of this testing system are four standard gaseous vessels injecting to glass flasks and hoses, two racks to set gas leakage detectors, two high-quality cameras for photographing, two Ethernet communication modems for transmitting video files with concentration of gas leakage instruments. Also, there is a laptop computer in which a software tool for receiving and displaying MPEC files is installed. Then, we developed a program for extracting numerals from video (MPEC) files which included gas concentration measured by gas leakage detectors.

A laptop computer has software to display MPEC files after receiving their video files from cameras and a program to extract numerically gaseous concentration on images transformed from MPEC files. Fig. 7 displays the two gas leakage detectors.

A numeric extracting program is coded and compiled by C++ builder. In this program, algorithms to extract numerals form assigned section and to perform image processing are implemented. They specifically transform and convert images to numerals. Their whole remote testing device for measuring concentration and initial response time gas leakage detectors is shown in Fig. 8.

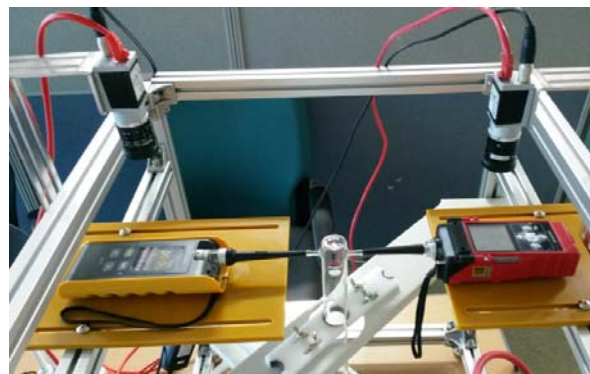

Fig. 5 A remote testing devices for measuring gas concentration (left: Korea' detector, right side: Japan's detector)

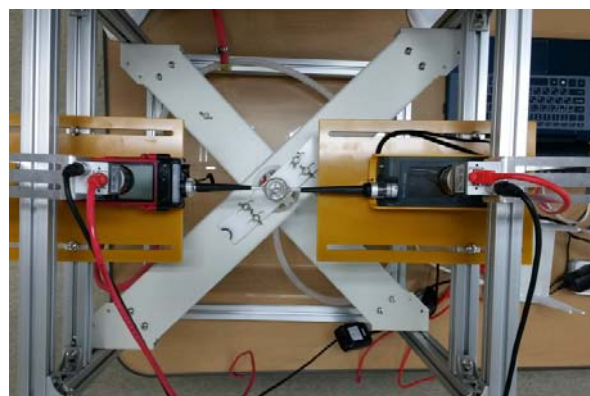

Fig. 6 View from above a remote measuring device

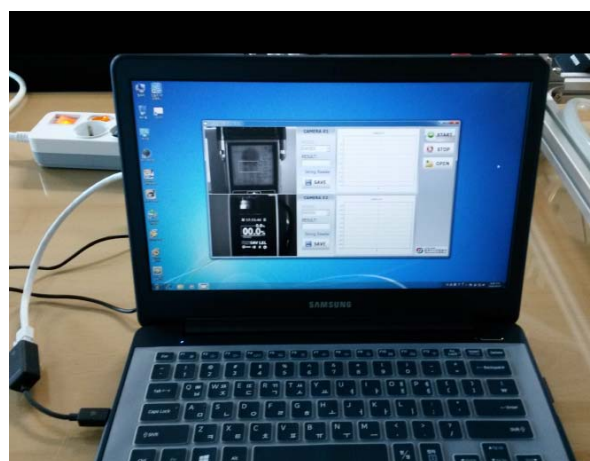

Fig. 7 A laptop computer installed software to extract numerals

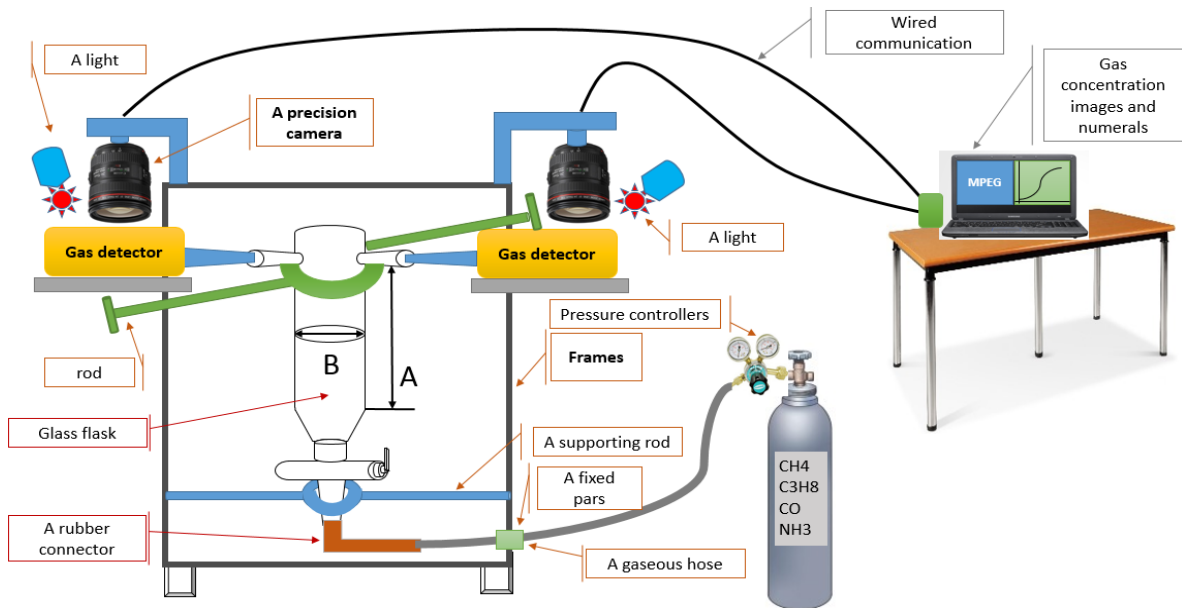

Fig. 8 A whole remote testing system for performing gas leakage detectors

### III. OPERATION OF THE TESTING SYSTEM

To test the performance of combustible and toxic gas leakage detectors, testing item and procedures are required. In those procedures, first, target gas leakage detectors on a manufactured measurement jig are set by two supporting stands. A bottom part of a glass flask is connected by a tapered rubber nozzle to standard gaseous vessels composed of seven type concentrations in case of methane. Every standard gaseous vessel can be changeable according to diverse concentration test. While gas concentration is continuously measured on top of a glass flask, the used gases have to be exhausted to vent of gas leakage detectors. Exhausted gases are dangerous. To avoid interaction with them, we equipped a fume hood. The fume hood is included in testing facility to measure gas concentration. That hum hood emits the used gases such methane, propane, monoxide, oxygen, hydrogen sulfide, and ammonia. While gas concentration is continuously measured, video files photographed by high-quality cameras with concentration are produced. Created MPEC files are sent to a laptop computer in real time. Those MPEG files are automatically displayed on the screen of that notebook as shown in Fig. 9. Simultaneously sections, where gas concentration is displayed, are cut and transformed to images in the MPEG files. Those gas concentration images are transformed into those numerals in real time. Extracted numerals with gas concentration are displayed and graphed on screen of laptop computer and those concentration numbers are saved in e-files at the same time. Sections of concentration displayed on gas leakage detector's LCD can be assigned. Our developed program converted MPEC files to color images, and to gray scale images. At the beginning, it made pattern of images with numbers from zero (0) to nine (9) as shown in Fig 10. Ten gray images are saved with pattern in operation program folder in computer. While testing gas leakage

detectors, if extracted and converted images are matched with their patterns, their images are converted to numbers. Arabic numbers represent the real gas concentration. Those concentrations are displayed and graphed on screen.

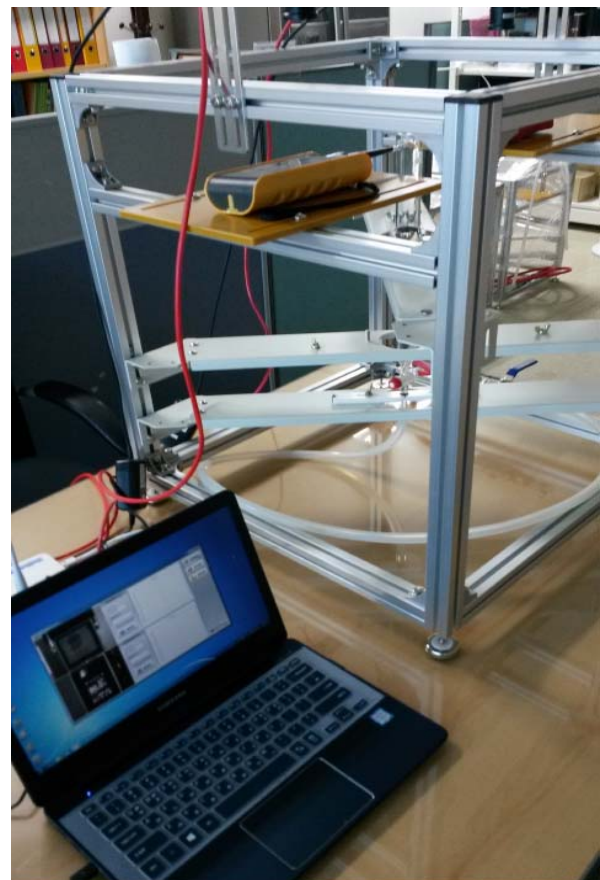

Fig. 9 A whole appearance of a remote gas detector testing system

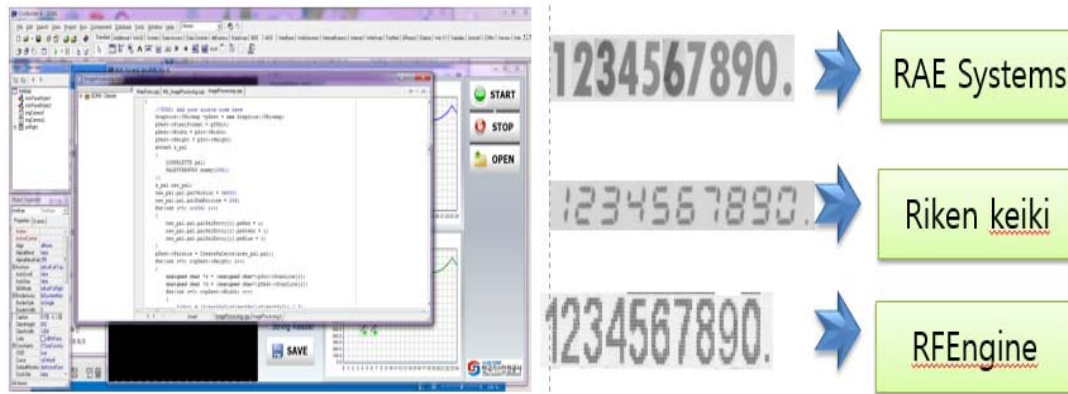

Fig. 10 The extraction method for MPEG concentration to numerals

Fig. 11 shows numerals of gas concentrations which are converted from images for testing Korea and USA gas leakage detectors. These are the recorded gas concentrations of two detectors for 150 seconds from starting test. Fig. 12 shows gas concentration data after 175 seconds.



Fig. 11 Measured concentrations for testing two gas leakage detectors (150 seconds)



Fig. 12 Graphs of measured concentration for testing of two gas leakage detectors (175 seconds)

#### IV. CONCLUSION

In industrial fields, a number of gaseous accidents are occurred. It is essential to efficiently prevent and manage those gas risks. To accomplish gas safety, excellent gas leakage detectors are distributed in industrial areas. Safety managers

have to check and inspect gas facilities with gas leakage instrument of the distinguished performances. So, we have to avoid even minimal and tiny gas accidents. A variety of gas leakage detectors are in the world.

In this research, to verify the performance of gas leakage detectors, we developed a remote testing system for measuring performances of diverse gas leakage detectors. This system measures gas concentration and initial response time of gas leakage detectors. To test gas leakage detectors, we manufactured standard gases with seven types of concentrations. Experimental jigs with a glass flask and two cameras with LAN modems are utilised. While extracting numerals from images with gas concentration, we developed a software program to automatically test gas detectors. This testing system changes MPEC files to grey images and processes eroding, warping, and filtering images. Extracted Arabic numerals of concentration are recorded and graphed. Those performances are verified. If they are distributed in gas industrial fields, gas safety is effectively managed. Our remote testing systems for measuring performance of gas detectors will discriminate best detectors. So, to create better detectors, development of multiple gas leakage detectors will be accelerated.

#### ACKNOWLEDGMENT

This study was supported by the Ministry of Trade, Industry and Energy under the theme of "Portable Combustible Gas Detector with Explosion Proof [Development of Portable Combustible and Toxic Gases Detector with IECEx Intrinsic Safety Certification]", (task number 20142020500140).

#### REFERENCES

- [1] Incident Investigation & Safety Checkup Division, Gas Incident Statistics, Korea Gas Safety Corporation, 2016.
- [2] Seong-Hwan Han, Hem-Chang Lee, Kyoshik Park, Tae-Ok Kim, "Consequence Analysis for Fire and Explosion Accidents in Propylene Recovery Process", KIGAS Vol.18(1), pp 52-60, 2014.
- [3] <http://news.ccstv.co.kr/sNews/pNewsView.php?&nBNo=31939> accessed on 27/02/2016
- [4] Gyou-tae Park and et al, "A Smart Monitoring System for Preventing Gas Risks in Indoor" IJECECE, Vol.9(6), 2015.
- [5] Gyou-tae Park and et al, "Research on Development and Accuracy Improvement of a Combustible gas leakage detector with Explosion Proof Using an IR Sensor", IJECECE Vol.10(4), pp. 360-364, 2014.

- [6] Gyou-tae Park, geunjun Lyu and et al, "A Study on the Development and Accuracy Improvement IR Combustible gas leakage detector with Explosion Proof", KIGAS Vol.18(3), pp 1~12, 2014.



**Gyoutae Park.** He was born at Gyeong-buk Province in South Korea on March 29th, 1970. Now he earned Ph.D degree in School of Electrical and Computer Engineering at University of Seoul, Korea in 2014. He earned the B.S. and M.S. degrees in Electronic Engineering at the Yeungnam University, Gyeongsan, Korea in 1996 and 1999, respectively. He is currently a senior researcher of Electrical and Computer Engineering-based Gas Safety Facilities at Korea Gas Safety Corporation (KGS). His research interests focus on IT convergence technology for gas safety measuring devices and system, catalytic and infrared gas sensors, and gas leakage detectors with explosion proof.

Address: 1390 Wongjung-ro, Maengdong-myon, Eumsung-gun, Chungbuk-do, 22738, Korea. E-mail: gtparkgs@kgs.or.kr



**Hiesik Kim** was born in 1953 in Gyoung-Ju, Korea. He received the Bachelor's degree in mechanical engineering from Seoul National University, Seoul, Korea, in 1977, a Master's degree in production engineering from the Korea Advanced Institute of Science and Technology (KAIST), Daejeon, Korea, and the Doctorate (Doktor-Ingenieur) degree in production engineering (FhG-IPA) from Stuttgart University, Stuttgart, Germany, in 1987, under the supervision of Prof. Dr.-Ing. H.-J. Warnecke. He was a Technical Official with the Ministry of Science and Technology of the Korean Government from 1979 to 1982 and as Senior Researcher with the CAD/CAM Research Laboratory, KAIST from 1987 to 1989. Since 1989, he has been a Professor with the Department of Electrical and Computer Engineering, University of Seoul, Seoul. He was the Vice Dean with the Engineering College. His current research interests include optical measurement of geometries, applications of sensors for automation and image processing. E-mail: drhskim@uos.ac.kr.