

# Vibrational Behavior of Cylindrical Shells in Axial Magnetic Field

Sedrak Vardanyan

**Abstract**—The investigation of the vibrational character of magnetic cylindrical shells placed in an axial magnetic field has important practical applications. In this work, we study the vibrational behaviour of such a cylindrical shell by making use of the so-called exact space treatment, which does not assume any hypothesis. We discuss the effects of several practically important boundary conditions on the vibrations of the described setup. We find that, for some cases of boundary conditions, e.g. clamped, simply supported or peripherally earthed, as well as for some values of the wave numbers, the vibrational frequencies of the shell are approximately zero. The theoretical and numerical exploration of this fact confirms that the vibrations are absent or attenuate very rapidly. For all the considered cases, the imaginary part of the frequencies is negative, which implies stability for the vibrational process.

**Keywords**—Free vibrations, magnetic cylindrical shells, exact space treatment, bending vibrational frequencies.

## I. INTRODUCTION

THE free bending vibrations of metallic shells placed in axial magnetic field are typically investigated by two common methods. The first one is based on averaged theories of plates and shells, while the second approach is based on the so-called exact space treatment. The averaged theories of plates and bending shells are developed quite well. The first hypothesis for developing the bending theory, known as the Kirchhoff-Love hypothesis, was presented by Kirchhoff and further developed by Love (see [1]). The further refinements of these ideas led to the so-called Reissner-Mindlin theories developed by Reissner [2] and Mindlin [3] as in the book [1]. Important contributions to the refined bending theory were made also by Ambartsumyan [4], where the case of zero shear stresses on interfacial surfaces of thin plates is considered. Comprehensive reviews of the above mentioned results can be found in Ozer [5] and Douglas et al. [6]. We have to mention that the application of Kirchhoff-Love and Reissner-Mindlin hypotheses for practical problems has several differences, and there are cases where the refined theories are applicable, and other cases where they are not. Particularly, as it is shown in [7], for investigating the stresses on the tip of the wedge shaped irradiated compound plates, one can effectively use the Reissner-Mindlin theory, while the Kirchhoff-Love theory for this case is not applicable. The averaged approach for plates' and shells' free bending problems was developed by Ambartsumyan et al. [8], [9] and Sarkisyan et al. [11]. The modulation problem for thermomagnetoelastic waves in magnetic field was solved by Bagdov and Movsisyan [12].

Sedrak Vardanyan is with the Plekhanov Russian University of Economics, Yerevan branch, Armenia (e-mail: vardanyan.sv@rea.ru).

Additionally, significant progress has been made in developing an approach to study the bending of plates and shells using the exact space treatment. This method was described by Novatsky in [13]. Applications of the exact space approach for free bending problems can be found in [14]-[16]. General relationships of magnetoelastic case were obtained by Kaliski [10], Kolski [17], and Baghdasaryan and Belubekyan [18]. Some problems for both cases were solved by Bagdov et al. [19]-[25] where the vibrations of magnetoelastic, piezoelectric, and ferromagnetic plates and shells were studied. The situation, when the internal and external surfaces of the shell are free from stresses and the magnetic field is continuous on them, is studied. Comparison of the results presented in these works shows that, for the mentioned cases, the averaged theories are not applicable. Because of that result, in this paper, we will use the exact space approach.

The free vibrations of a circular plate, which are composed of a transversally isotropic, functionally graded piezoelectric material which is placed in a uniform magnetic field, are studied by Dai et al. [26]. The case of functionally graded piezoelectric material is discussed and it is assumed that the material properties depend on the thickness of the circular plate by exponential law. That problem is solved by means of the state space method.

The influence of boundary conditions on vibration characteristics of a shell is very interesting and has practical applications for designing electromagnetic devices. For this reason, we are going to investigate vibrational characteristics of a magnetic shell which is placed in a magnetic field. We are going to study different types of boundary conditions. Particularly, we are considering cases when the internal surface is clamped, simply supported, or peripherally earthed, and we assume the external surface to be free from stresses.

## II. THE BASIC EQUATIONS

In our work, we adopt the model described in [17], [19], namely, a cylindrical magnetic shell, which is placed in axial magnetic field  $\vec{H} = \vec{H}_0 + \vec{h}$ , as it is shown in Fig. 1.

Here,  $R$  is the radius of the cylinder, and  $2h$  is a thickness of the shell. Following [27], we assume the presence of undisturbed and disturbed magnetic fields,  $\vec{H}_0$  and  $\vec{h} = (h_r, h_z)$ , and we assume a cylindrical symmetry of the problem. By using  $a$  and  $b$ , we denote the speeds of longitudinal and transversal elastic waves, and  $\rho$  is going to be the density of shell's material. In cylindrical coordinates  $(r, z)$ , the equations of motion for the shell are:

$$\frac{\partial^2 u_r}{\partial r^2} + \frac{b^2}{a^2} \frac{\partial^2 u_r}{\partial z^2} + \zeta \frac{\partial^2 u_z}{\partial r \partial z} + \frac{1}{r} \frac{\partial u_r}{\partial r} - \frac{1}{r^2} u_r = \frac{1}{a^2} \frac{\partial^2 u_r}{\partial t^2} - \frac{a_1^2}{a^2} \left( \frac{\partial h_r}{\partial z} - \frac{\partial h_z}{\partial r} \right); \quad (1)$$

$$\frac{b^2}{a^2} \frac{\partial^2 u_z}{\partial r^2} + \frac{\partial^2 u_z}{\partial z^2} + \zeta \frac{\partial^2 u_z}{\partial r \partial z} + \frac{b^2}{a^2} \frac{1}{r} \frac{\partial u_z}{\partial r} + \frac{\zeta}{r} \frac{\partial u_r}{\partial z} = \frac{1}{a^2} \frac{\partial^2 u_z}{\partial t^2};$$

where  $\alpha_1^2 = \frac{H_0^2}{4\pi\rho}$ ,  $\zeta = 1 - \frac{b^2}{a^2}$  and  $\bar{u} = (u_r, u_z)$  is the displacement vector.

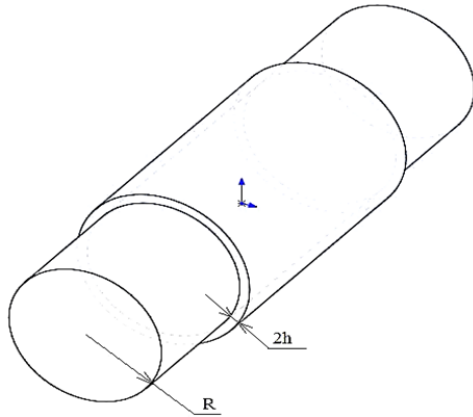

Fig. 1 Cylindrical shell under axial magnetic field

The Maxwell's equation for electromagnetic induction leads to:

$$\frac{\partial \bar{h}}{\partial t} = \text{rot}(\bar{v} \times \bar{H}_0) + \nu_m \Delta \bar{h}; \quad (2)$$

where  $\bar{v} = \frac{\partial \bar{u}}{\partial t}$  and  $\nu_m$  is the magnetic viscosity.

The disturbed magnetic field vector and electrical potential is defined by the relationships (3) and (4):

$$\Delta \bar{h} = \left( \Delta h_r - \frac{h_r}{r^2} \right) \bar{e}_r + \Delta h_z \bar{e}_z; \quad (3)$$

$$h_r = \frac{\partial \varphi}{\partial r}, \quad h_z = \frac{\partial \varphi}{\partial z}; \quad (4)$$

where  $\bar{e}_r, \bar{e}_z$  are the unit vectors along the axis  $r, z$ , and  $\varphi$  is the electric potential.

In order to explore the problem completely, we also have to take into consideration the Lorentz force, which can be introduced as (5) and (6):

$$F_r = -\frac{1}{4\pi\rho} (\text{rot} \bar{h} \times \bar{H}_0)_r = -\frac{H_0}{4\pi\rho} \left( \frac{\partial h_r}{\partial z} - \frac{\partial h_z}{\partial r} \right) \neq 0; \quad (5)$$

$$F_z = -\frac{1}{4\pi\rho} (\text{rot} \bar{h} \times \bar{H}_0)_z = 0. \quad (6)$$

From (3), the time derivatives of the magnetic field vector's projections on  $r, z$  axis are given by:

$$\frac{\partial h_r}{\partial t} = H_0 \frac{\partial^2 u_r}{\partial t \partial z} + \nu_m \left( \frac{\partial^2 h_r}{\partial r^2} + \frac{1}{r} \frac{\partial h_r}{\partial r} + \frac{\partial^2 h_r}{\partial z^2} + \frac{h_r}{r^2} \right);$$

$$\frac{\partial h_z}{\partial t} = -H_0 \left( \frac{\partial^2 u_r}{\partial t \partial r} + \frac{1}{r} \frac{\partial u_r}{\partial t} \right) + \nu_m \left( \frac{\partial^2 h_z}{\partial r^2} + \frac{1}{r} \frac{\partial h_z}{\partial r} + \frac{\partial^2 h_z}{\partial z^2} \right). \quad (7)$$

### III. THE BOUNDARY CONDITIONS

We will consider four types of boundary conditions:

**Type 1.** The internal surface of the shell is clamped, peripherally earthed, while the external surface is free from stresses. Additionally, there is a continuity condition for the magnetic field vector on the external surface.

More precisely, on the internal surface  $r = R - h$ , we impose the conditions (8):

$$u_r = 0, \quad u_z = 0, \quad \varphi = 0; \quad (8)$$

while on the external surface  $r = R + h$  we impose:

$$\sigma_{rr} = 0, \quad \sigma_{rz} = 0, \quad h_r = \bar{h}_r, \quad h_z = \bar{h}_z; \quad (9)$$

**Type 2.** The internal surface of the shell is simply supported, peripherally earthed and, additionally, the external surface is free from stresses. As before, there is a continuity condition for the magnetic field.

On the internal surface  $r = R - h$  we have:

$$\sigma_{rr} = 0, \quad u_z = 0, \quad \varphi = 0. \quad (10)$$

On the external surface  $r = R + h$  we have:

$$\sigma_{rr} = 0, \quad \sigma_{rz} = 0, \quad h_r = \bar{h}_r, \quad h_z = \bar{h}_z. \quad (11)$$

**Type 3.** Internal surface of the shell is clamped, the external surface is free from stresses, and additionally, we impose continuity condition on the magnetic field vector not only on the external surface, but also on the internal one.

On the Internal surface,  $r = R - h$  we have:

$$u_r = 0, \quad u_z = 0, \quad h_r = \bar{h}_r, \quad h_z = \bar{h}_z. \quad (12)$$

On the external surface,  $r = R + h$  we have:

$$\sigma_{rr} = 0, \quad \sigma_{rz} = 0, \quad h_r = \bar{h}_r, \quad h_z = \bar{h}_z. \quad (13)$$

**Type 4:** Internal surface of the shell is simply supported, the external surface is free from stresses, and magnetic field vector continuity condition exists on the internal and external surfaces.

On the internal surface,  $r = R - h$  we have:

$$\sigma_{rr} = 0, \quad u_z = 0, \quad h_r = \bar{h}_r, \quad h_z = \bar{h}_z. \quad (14)$$

On the external surface,  $r = R + h$  we have:

$$\sigma_{rr} = 0, \sigma_{rz} = 0, h_r = \bar{h}_r, h_z = \bar{h}_z. \quad (15)$$

#### IV. SOLVING THE EQUATIONS

We are going to assume ansatz (16) for the solutions of (1) and (7):

$$\begin{aligned} u_r &= (A_j I_1(\xi_j) + A'_j K_1(\xi_j)) e^{-i\omega t + ikz} + c.c., \\ u_z &= (B_j I_0(\xi_j) + B'_j K_0(\xi_j)) e^{-i\omega t + ikz} + c.c.; \\ h_z &= (C_j H_0 I_0(\xi_j) + C'_j H_0 K_0(\xi_j)) e^{-i\omega t + ikz} + c.c., \\ h_r &= (D_j H_0 I_1(\xi_j) + D'_j H_0 K_1(\xi_j)) e^{-i\omega t + ikz} + c.c.; \\ \varphi &= F_j I_0(\xi_j) e^{-i\omega t + ikz} + F'_j K_0(\xi_j) e^{-i\omega t + ikz} + c.c., \\ \xi_j &= r v_j, \quad j = 1, 2, 3; \end{aligned} \quad (16)$$

where  $\omega$  and  $k$  are the vibration frequency and the wave number, respectively.  $A_j, \dots, F_j$  and the corresponding primed quantities are constants. Additionally, summation over the repeated indices  $j=1 \dots 3$  is implied. Equations (16) have the form of a plane wave which is propagating along the  $z$ -axis. Here,  $I_{0,1}, K_{0,1}$  are the Bessel functions of the second kind of complex argument. We are going to make use of the well-known relationships of Bessel functions (17):

$$\begin{aligned} I_0'(\xi) &= I_1(\xi), \quad K_0'(\xi) = -K_1(\xi), \\ \frac{dI_1(\xi)}{d\xi} + \frac{1}{\xi} I_1(\xi) &= I_0(\xi), \\ \frac{dK_1(\xi)}{d\xi} + \frac{1}{\xi} K_1(\xi) &= -K_0(\xi). \end{aligned} \quad (17)$$

By plugging (16) into (1) and (7), we find:

$$\begin{aligned} A_j \left( v_j^2 - \frac{b^2}{a^2} k^2 + \frac{\omega^2}{a^2} \right) + \zeta i k v_j B_j &= \frac{a_1^2}{a^2} H_0 (v_j D_j - i k C_j), \\ \left( \frac{b^2}{a^2} v_j^2 - k^2 + \frac{\omega^2}{a^2} \right) B_j + \zeta i k v_j A_j &= 0; \\ C_j (-i\omega + v_m (k^2 - v_j^2)) &= -i\omega v_j A_j, \\ D_j (-i\omega + v_m (k^2 - v_j^2)) &= \omega k A_j; \\ A'_j \left( v_j^2 - \frac{b^2}{a^2} k^2 + \frac{\omega^2}{a^2} \right) - \zeta i k v_j B'_j &= \frac{a_1^2}{a^2} H_0 (-v_j D'_j - i k C'_j), \\ B'_j \left( \frac{b^2}{a^2} v_j^2 - k^2 + \frac{\omega^2}{a^2} \right) - \zeta i k v_j A'_j &= 0; \\ C'_j (-i\omega + v_m (k^2 - v_j^2)) &= i\omega v_j A'_j, \\ D'_j (-i\omega + v_m (k^2 - v_j^2)) &= \omega k A'_j; \\ D_j &= F_j v_j, \quad C_j = i k F_j, \\ D'_j &= F'_j v_j, \quad C'_j = i k F'_j. \end{aligned} \quad (18)$$

Accordingly, we obtain a system of four linear and homogeneous algebraic equations on coefficients  $A_j, B_j, C_j, D_j$  and another similar system for  $A'_j, B'_j, C'_j, D'_j$ . Requiring system (18) to have non-trivial solutions, we impose:

$$\det \begin{vmatrix} v_j^2 - \frac{b^2}{a^2} k^2 + \frac{\omega^2}{a^2} & \zeta i k v_j & -H_0 \frac{a_1^2}{a^2} v_j & i k H_0 \frac{a_1^2}{a^2} \\ \zeta i k v_j & v_j^2 - \frac{b^2}{a^2} k^2 + \frac{\omega^2}{a^2} & 0 & 0 \\ i\omega v_j & 0 & -i\omega + v_m (k^2 - v_j^2) & 0 \\ \omega k & 0 & 0 & -i\omega + v_m (k^2 - v_j^2) \end{vmatrix} = 0. \quad (19)$$

In the following, we assume  $\frac{a_1^2}{a^2} \ll 1$  and also small values for  $v_m$ . From the determinant equation (19), we find:

$$v_1^2 = k^2 - \frac{\omega^2}{a^2} - \frac{a_1^2}{a^2} \left( k^2 - \frac{\omega^2}{a^2} \right) \left( 1 - i \frac{\omega v_m}{a^2} \right); \quad (20)$$

$$v_2^2 = k^2 - \frac{\omega^2}{a^2} + \frac{a_1^2}{b^2} k^2 - i \frac{\omega a_1^2 k^2 v_m}{b^4}; \quad (21)$$

$$v_3^2 = k^2 - i \frac{\omega}{v_m} - \frac{a_1^2}{a^2} \left( \zeta \frac{a^2}{b^2} k^2 + i \frac{\omega}{v_m} \right). \quad (22)$$

We now impose the boundary conditions.

**Type 1.** Expressing the coefficients  $B_j$  and  $B'_j$  through  $A_j$  and  $A'_j$  at  $r = R - h$ , we have

$$A_j I_1((R-h)v_j) + A'_j K_1((R-h)v_j) = 0; \quad (23)$$

In what follows, we assume  $\frac{a_1^2}{a^2} \ll 1$  and also small values for  $v_m$ . From the determinant equation (19), we find:

$$\begin{aligned} -\frac{\zeta i k v_j}{\frac{b^2}{a^2} v_j^2 - k^2 + \frac{\omega^2}{a^2}} A_j I_0((R-h)v_j) + \\ + \frac{\zeta i k v_j}{\frac{b^2}{a^2} v_j^2 - k^2 + \frac{\omega^2}{a^2}} A'_j K_0((R-h)v_j) &= 0; \end{aligned} \quad (24)$$

$$\begin{aligned} \frac{1}{v_j - i\omega + v_m (k^2 - v_j^2)} A_j I_0((R-h)v_j) + \\ + \frac{1}{v_j - i\omega + v_m (k^2 - v_j^2)} A'_j K_0((R-h)v_j) &= 0. \end{aligned} \quad (25)$$

Using the continuity of magnetic field vector on the external surface, we have for  $r > R + h$ :

$$\bar{h}_r = \bar{D}H_0K_1(rv)e^{-i\alpha r + kz} + c.c., \quad \bar{h}_z = \bar{C}H_0K_0(rv)e^{-i\alpha r + kz} + c.c. \quad (26) \quad \text{where}$$

In the region outside the shell the electrical potential satisfies (27):

$$\Delta\varphi = \frac{1}{r} \frac{\partial}{\partial r} \left( r \frac{\partial \varphi}{\partial r} \right) + \frac{\partial^2 \varphi}{\partial z^2} = \frac{\partial \bar{h}_r}{\partial r} + \frac{\bar{h}_r}{r} + \frac{\partial \bar{h}_z}{\partial z} = 0. \quad (27)$$

Plugging (26) into (27), we can find:

$$-v\bar{D} + ik\bar{C} = 0. \quad (28)$$

From (9), we have

$$D_j I_1((R+h)v_j) + D'_j K_1((R+h)v_j) = i\bar{C}K_1\{(R+h)k\}; \quad (29)$$

$$C_j I_0((R+h)v_j) + C'_j K_0((R+h)v_j) = \bar{C}K_0\{(R+h)k\};$$

or

$$\frac{\omega k}{-i\omega + v_m(k^2 - v_j^2)} (A_j I_1((R+h)v_j) + A'_j K_1((R+h)v_j)) =$$

$$= \frac{\omega v_j}{-i\omega + v_m(k^2 - v_j^2)} \frac{K_1\{(R+h)k\}}{K_0\{(R+h)k\}} \times$$

$$\times \{A'_j K_0((R+h)v_j) - A_j I_0((R+h)v_j)\}. \quad (30)$$

From the stress-free conditions, we have:

$$\zeta' ik \left( -\frac{\zeta ik v_j}{\frac{b^2}{a^2} v_j^2 - k^2 + \frac{\omega^2}{a^2}} A_j I_0((R+h)v_j) + \right.$$

$$\left. + \frac{\zeta ik v_j}{\frac{b^2}{a^2} v_j^2 - k^2 + \frac{\omega^2}{a^2}} A'_j K_0((R+h)v_j) \right)$$

$$+ v_j (A_j I_1((R+h)v_j) + A'_j K_1((R+h)v_j)) +$$

$$+ \frac{\zeta' v_j}{\zeta_j^+} (A_j I_1((R+h)v_j) + A'_j K_1((R+h)v_j)) = 0; \quad (31)$$

$$v_j \left( \frac{\zeta ik v_j}{\frac{b^2}{a^2} v_j^2 - k^2 + \frac{\omega^2}{a^2}} A_j I_1((R+h)v_j) + \frac{\zeta ik v_j}{\frac{b^2}{a^2} v_j^2 - k^2 + \frac{\omega^2}{a^2}} A'_j K_1((R+h)v_j) \right) -$$

$$- ik (A_j I_1((R+h)v_j) + A'_j K_1((R+h)v_j)) = 0; \quad (32)$$

where  $\zeta' = \zeta - \frac{b^2}{a^2}$ , and in (26), (31) and (32), we have summation over j running from 1 to 3. Accordingly, we found six linear, homogeneous, algebraic equations on coefficients  $A_{1,2,3}$  and  $A'_{1,2,3}$ . Analogously, the condition of (26), (31), and (32) having non-trivial solutions can be presented as:

$$\det \|\alpha_{ij}\| = 0, \quad i, j = \overline{1, 2, \dots, 6}; \quad (33)$$

$$\alpha_{1j} = I_1((R-h)v_j), \quad \alpha_{1p} = K_1((R-h)v_p),$$

$$\alpha_{2j} = -\frac{\zeta ik v_j}{\frac{b^2}{a^2} v_j^2 - k^2 + \frac{\omega^2}{a^2}} I_0((R-h)v_j),$$

$$\alpha_{2p} = \frac{\zeta ik v_p}{\frac{b^2}{a^2} v_p^2 - k^2 + \frac{\omega^2}{a^2}} K_0((R-h)v_p),$$

$$\alpha_{3j} = \frac{1}{v_j - i\omega + v_m(k^2 - v_j^2)} I_0((R-h)v_j),$$

$$\alpha_{3p} = \frac{1}{v_p - i\omega + v_m(k^2 - v_p^2)} K_0((R-h)v_p),$$

$$\alpha_{4j} = \frac{\omega k}{-i\omega + v_m(k^2 - v_j^2)} I_1((R+h)v_j) +$$

$$+ \frac{\omega v_j}{-i\omega + v_m(k^2 - v_j^2)} \frac{K_1((R+h)k)}{K_0((R+h)k)} I_0((R+h)v_j),$$

$$\alpha_{4p} = \frac{\omega k}{-i\omega + v_m(k^2 - v_p^2)} K_1((R+h)v_p) -$$

$$- \frac{\omega v_p}{-i\omega + v_m(k^2 - v_p^2)} \frac{K_1((R+h)k)}{K_0((R+h)k)} K_0((R+h)v_p),$$

$$\alpha_{5j} = v_j I_0((R+h)v_j) - \frac{b^2}{a^2} \frac{2}{R+h} I_1((R+h)v_j) +$$

$$+ \frac{\zeta \zeta' k^2 v_j}{\frac{b^2}{a^2} v_j^2 - k^2 + \frac{\omega^2}{a^2}} I_0((R+h)v_j),$$

$$\alpha_{5p} = -v_p K_0((R+h)v_p) - \frac{b^2}{a^2} \frac{2}{R+h} K_1((R+h)v_p) -$$

$$- \frac{\zeta \zeta' k^2 v_p}{\frac{b^2}{a^2} v_p^2 - k^2 + \frac{\omega^2}{a^2}} K_0((R+h)v_p),$$

$$\alpha_{6j} = ik I_1((R+h)v_j) - \frac{\zeta ik v_j^2}{\frac{b^2}{a^2} v_j^2 - k^2 + \frac{\omega^2}{a^2}} I_1((R+h)v_j),$$

$$\alpha_{6p} = ik K_1((R+h)v_p) - \frac{\zeta ik v_p^2}{\frac{b^2}{a^2} v_p^2 - k^2 + \frac{\omega^2}{a^2}} K_1((R+h)v_p), \quad (34)$$

$$j = 1, 2, 3, \quad p = j + 3.$$

**Type 2.** The difference between the type-1 boundary condition and the type-2 is only in the first stress relationship:

$$v_j (A_j I_1'((R-h)v_j) + A'_j K_1'((R-h)v_j)) +$$

$$+ \frac{\zeta'}{R-h} (A_j I_1((R-h)v_j) + A'_j K_1((R-h)v_j)) +$$

$$+ \zeta' ik \left( -\frac{\zeta ik v_j}{\frac{b^2}{a^2} v_j^2 - k^2 + \frac{\omega^2}{a^2}} A_j I_0((R-h)v_j) + \right.$$

$$\left. + \frac{\zeta i k v_j}{\frac{b^2}{a^2} v_j^2 - k^2 + \frac{\omega^2}{a^2}} A'_j K_0((R-h)v_j) \right) = 0. \quad (35)$$

Similarly, the condition for (24), (25), (30)-(32) and (35) having non-trivial solutions can be presented by the condition (33), but we have to take into consideration the fact that we have the relationships (36):

$$\begin{aligned} \alpha_{1j} &= v_j I_0((R-h)v_j) - \frac{b^2}{a^2} \frac{2}{R-h} I_1((R-h)v_j) + \\ &+ \frac{\zeta \zeta' k^2 v_j}{\frac{b^2}{a^2} v_j^2 - k^2 + \frac{\omega^2}{a^2}} I_0((R-h)v_j) \\ \alpha_{1p} &= -v_p K_0((R-h)v_p) - \frac{b^2}{a^2} \frac{2}{R-h} K_1((R-h)v_p) - \\ &- \frac{\zeta \zeta' k^2 v_p}{\frac{b^2}{a^2} v_p^2 - k^2 + \frac{\omega^2}{a^2}} K_0((R-h)v_p) \end{aligned} \quad (36)$$

**Type 3.** For this case, we have Eqs. (23), (24), (30)-(32) and additionally the magnetic field continuity conditions on the internal surface  $r = R - h$ . Making use of this conditions, we have:

$$\begin{aligned} &\frac{\omega k}{-i\omega + v_m(k^2 - v_j^2)} (A_j I_1((R-h)v_j) + A'_j K_1((R-h)v_j)) = \\ &= \frac{\omega v_j}{-i\omega + v_m(k^2 - v_j^2)} \frac{I_1\{(R-h)k\}}{I_0\{(R-h)k\}} \times \\ &\times \{A'_j K_0((R-h)v_j) - A_j I_0((R-h)v_j)\} \end{aligned} \quad (37)$$

The existing condition of non-trivial solution for the system of the mentioned equations is similar to the type-1 case with different coefficients of (37):

$$\begin{aligned} \alpha_{3j} &= \frac{\omega k}{-i\omega + v_m(k^2 - v_j^2)} I_1((R-h)v_j) + \\ &+ \frac{\omega v_j}{-i\omega + v_m(k^2 - v_j^2)} \frac{I_1\{(R-h)k\}}{I_0\{(R-h)k\}} I_0((R-h)v_j) \\ \alpha_{3p} &= \frac{\omega k}{-i\omega + v_m(k^2 - v_p^2)} K_1((R-h)v_p) - \\ &- \frac{\omega v_p}{-i\omega + v_m(k^2 - v_p^2)} \frac{I_1\{(R-h)k\}}{I_0\{(R-h)k\}} K_0((R-h)v_p) \end{aligned} \quad (38)$$

**Type 4.** Finally, for this case, we have (24), (34), (36), (30)-(32). The non-triviality condition is similar to (33), and  $\alpha_{ij}$  coefficients are similar to (34) with difference of two conditions. The coefficients corresponding to the mentioned conditions are presented in (36) and (38).

TABLE I  
 BOUNDARY CONDITIONS OF TYPE-1, NUMERICAL VALUES OF VIBRATION FREQUENCIES' REAL PARTS (Re  $\omega$ )

$k$	$H_0$	0.1	0.2	0.3	0.4	0.5
$10^5$		$10^{-7}$	$10^{-7}$	$10^{-7}$	$10^{-7}$	$10^{-7}$
$2*10^5$		$10^{-7}$	$10^{-7}$	$10^{-7}$	$10^{-7}$	$10^{-7}$
$3*10^5$		$10^{-7}$	$10^{-7}$	$10^{-7}$	$10^{-7}$	$10^{-7}$
$4*10^5$		$10^{-7}$	-0.00009	0.00086	$10^{-7}$	0.00002
$5*10^5$	0.00006	0.0012	-0.0021	0.0028	-0.0034	-0.0034
$6*10^5$	0.0011	-0.0024	-0.0033	-0.0280	0.0047	0.0047
$7*10^5$	0.002	-0.0034	0.0044	-0.0051	0.0058	0.0058
$8*10^5$	-0.0029	0.0043	-0.0052	-0.006	0.0066	0.0066
$9*10^5$	-0.0035	0.0049	0.0059	-0.0066	-0.0073	-0.0073
$10^6$	-0.0041	0.00549	0.0064	0.0071	-0.0077	-0.0077

## V. NUMERICAL RESULTS AND CONCLUSIONS

We now solve the determinant equation (33) numerically for four types of boundary conditions. As a shell's material, we take aluminum with the following parameters:

Young's modulus  $E = 0.69 * 10^5 \text{ MPa}$ .

Poisson's ratio  $\nu = 0.32$ .

Density  $\rho = 2712 \text{ kg/m}^3$ .

Longitudinal wave speed  $a = \sqrt{\frac{E}{\rho}} = 1595.06 \text{ m/s}$ .

Transversal wave speed  $b = \sqrt{\frac{(1-\nu)E}{(1+\nu)(1-2\nu)\rho}} = 1908.06 \text{ m/s}$ .

Electrical conductivity  $\sigma = 35 * 10^6 \text{ sim/m}$ .

Magnetic viscosity  $v_m = \frac{c^2}{4\pi\sigma} = 2 * 10^7 \text{ m}^3 / \text{s}^2 \text{ sim}$ .

Alfven's wave speed  $a_1 = \sqrt{\frac{H_0^2}{4\pi\rho}}$ .

The geometrical sizes of the shell are taken to be:  $h = 0.001 \text{ m}$ ,  $R = 0.05 \text{ m}$ .

TABLE II  
 BOUNDARY CONDITIONS OF TYPE-1, NUMERICAL VALUES OF VIBRATION FREQUENCIES' IMAGINARY PARTS (Im  $\omega$ )

$k$	$H_0$	0.1	0.2	0.3	0.4	0.5
$10^5$		-0.103585	-0.103583	-0.103583	-0.103583	-0.103583
$2*10^5$		-0.103584	-0.103583	-0.103583	-0.103583	-0.103583
$3*10^5$		-0.103584	-0.103583	-0.103583	-0.103583	-0.103582
$4*10^5$		-0.103584	0.181235	0.181235	-0.103583	0.000146
$5*10^5$	0.127234	0.127297	0.127321	0.127327	0.127323	0.127323
$6*10^5$	0.091583	0.091390	0.091234	0.517539	0.090969	0.090969
$7*10^5$	0.066183	0.065739	0.06541	0.065135	0.064892	0.064892
$8*10^5$	0.047178	0.046496	0.046005	0.045603	0.045254	0.045254
$9*10^5$	0.032452	0.031546	0.030904	0.030384	0.029937	0.029937
$10^6$	0.020747	0.019628	0.018844	0.018213	0.017675	0.017675

We perform the calculations for various magnetic field values  $H_0 = 10^5, \dots, 10^4 \text{ T}$ . For these parameters, we present the numerically obtained bending frequencies for four types of boundary conditions (see Tables I-IV). It should be noted that the transcendental equations being solved here have infinitely many roots, but for us, the interesting ones are those the

absolute values of which are the closest to zero. We present precisely these solutions.

TABLE III  
 BOUNDARY CONDITIONS OF TYPE-2, NUMERICAL VALUES OF VIBRATION  
 FREQUENCIES' REAL PARTS (  $\text{Re } \omega$  )

$k$	$H_0$	0.1	0.2	0.3	0.4	0.5
$10^5$	$10^{-8}$	$10^{-8}$	$10^{-8}$	$10^{-8}$	438.818	226.0891
$2*10^5$	$10^{-8}$	$10^{-8}$	$10^{-8}$	$10^{-8}$	172.686	108.9462
$3*10^5$	$10^{-8}$	$10^{-8}$	$10^{-8}$	222.471	112.421	72.4278
$4*10^5$	$10^{-8}$	0.57689	154.704	83.9517	54.4747	
$5*10^5$	$10^{-8}$	$10^{-8}$	120.978	67.2693	43.8222	
$6*10^5$	$10^{-8}$	-0.14006	100.001	56.3263	36.8023	
$7*10^5$	$10^{-8}$	224.151	85.5935	48.6305	31.8615	
$8*10^5$	-1.14726	218.924	75.0953	42.9647	28.2309	
$9*10^5$	-1.316855	178.300	67.1454	38.6667	25.4906	
$10^6$	194.594	149.771	60.9736	35.3513	23.3965	

These numerical checks confirm that the real parts of the free bending frequencies are approximately zero for some values of the wave numbers. These results, particularly the negativity of the imaginary part of the bending vibrational frequencies, confirm that the peripherally earthed, clamped, or simply supported boundary conditions have an impact on magnetic vibrations as attenuation conditions. In the case, when the internal and external surfaces of the shell are free from stresses, the boundary conditions can be viewed as stimulators for vibrations, while for the scenarios studied in this paper the effect is opposite.

TABLE IV  
 BOUNDARY CONDITIONS OF TYPE-2, NUMERICAL VALUES OF VIBRATION  
 FREQUENCIES' IMAGINARY PARTS (  $\text{Im } \omega$  )

$k$	$H_0$	0.1	0.2	0.3	0.4	0.5
$10^5$		-0.103585	-0.145199	-0.103583	-147.822	-30.7525
$2*10^5$		-0.103584	-0.103583	-0.145199	-23.2815	-15.1732
$3*10^5$		-0.103583	-0.103583	-28.9107	-15.3821	-10.2147
$4*10^5$		-0.103584	-167.732	-20.4537	-11.5805	-7.7571
$5*10^5$		-0.103584	-0.145199	-16.1300	-9.3294	-6.2893
$6*10^5$		-0.145199	-0.655049	-13.3830	-7.8398	-5.3157
$7*10^5$		-0.145199	-102.878	-11.4652	-6.7827	-4.6256
$8*10^5$		-66.6034	-64.1050	-10.0456	-5.9963	-4.1145
$9*10^5$		-62.5484	-22.7916	-8.9511	-5.3917	-3.7250
$10^6$		0.0089	-18.9253	-8.0812	-4.9170	-3.4241

TABLE V  
 BOUNDARY CONDITIONS OF TYPE-3, NUMERICAL VALUES OF VIBRATION  
 FREQUENCIES' REAL PARTS (  $\text{Re } \omega$  )

$k$	$H_0$	0.1	0.2	0.3	0.4	0.5
$10^5$		4207.179	3446.062	3055.766	2802.722	2624.180
$2*10^5$		3127.034	2556.076	2262.984	2078.567	1955.880
$3*10^5$		2629.957	2144.676	1898.753	1748.752	1655.295
$4*10^5$		2325.042	1893.226	1677.223	1549.672	1476.028
$5*10^5$		2112.610	1718.585	1524.035	1413.004	1354.462
$6*10^5$		1953.262	1587.927	1409.895	1311.901	1265.670
$7*10^5$		1827.786	1485.281	1320.576	1233.350	1197.599
$8*10^5$		1725.522	1401.799	1248.210	1170.169	1143.610
$9*10^5$		1640.005	1332.125	1188.039	1118.021	1099.703
$10^6$		1567.053	1272.798	1136.993	1074.113	1063.305

TABLE VI  
 BOUNDARY CONDITIONS OF TYPE-3, NUMERICAL VALUES OF VIBRATION  
 FREQUENCIES' IMAGINARY PARTS (  $\text{Im } \omega$  )

$k$	$H_0$	0.1	0.2	0.3	0.4	0.5
$10^5$		-1125.350	-840.005	-731.295	-662.790	-611.880
$2*10^5$		-781.276	-613.008	-535.695	-483.903	-442.873
$3*10^5$		-644.448	-511.537	-446.484	-401.164	-363.308
$4*10^5$		-564.715	-450.130	-392.008	-350.114	-313.472
$5*10^5$		-510.541	-407.642	-354.072	-314.232	-277.944
$6*10^5$		-470.495	-375.895	-325.569	-287.034	-250.647
$7*10^5$		-439.261	-350.953	-303.063	-265.373	-228.627
$8*10^5$		-413.975	-330.651	-284.658	-247.509	-210.243
$9*10^5$		-392.933	-313.685	-269.207	-232.387	-194.507
$10^6$		-375.050	-299.215	-255.971	-219.325	-180.775

TABLE VII  
 BOUNDARY CONDITIONS OF TYPE 4, NUMERICAL VALUES OF VIBRATION  
 FREQUENCIES' REAL PARTS (  $\text{Re } \omega$  )

$k$	$H_0$	0.1	0.2	0.3	0.4	0.5
$10^5$		$10^{-8}$	$10^{-8}$	$10^{-8}$	$10^{-8}$	$10^{-8}$
$2*10^5$		$10^{-10}$	$10^{-8}$	$10^{-8}$	$10^{-8}$	$10^{-8}$
$3*10^5$		$10^{-8}$	$10^{-8}$	$10^{-10}$	$10^{-8}$	70.4725
$4*10^5$		$10^{-8}$	$10^{-8}$	151.389	81.4067	52.4569
$5*10^5$		$10^{-8}$	$10^{-8}$	117.603	64.6237	41.7228
$6*10^5$		$10^{-8}$	228.407	96.4892	53.5538	34.5996
$7*10^5$		$10^{-8}$	222.576	81.8988	45.6998	29.5295
$8*10^5$		$10^{-8}$	216.606	71.1712	39.8375	25.7383
$9*10^5$		$10^{-8}$	172.044	62.9365	35.2949	22.7973
$10^6$		$10^{-8}$	144.683	56.4098	31.6717	20.4501

TABLE VIII  
 BOUNDARY CONDITIONS OF TYPE 4, NUMERICAL VALUES OF VIBRATION  
 FREQUENCIES' IMAGINARY PARTS (  $\text{Im } \omega$  )

$k$	$H_0$	0.1	0.2	0.3	0.4	0.5
$10^5$		-0.145199	-0.103584	-0.103583	-0.103583	-0.103583
$2*10^5$		-0.103584	-0.103583	-0.103583	-0.103583	-0.103583
$3*10^5$		-0.103584	-0.103583	-0.103583	-0.103583	-10.0897
$4*10^5$		-0.145199	-0.103583	-20.5366	-11.4840	-7.6217
$5*10^5$		-0.145199	-0.145199	-16.1761	-9.2180	-6.1435
$6*10^5$		-104.8034	-135.790	-13.4060	-7.71491	-5.1581
$7*10^5$		-104.6211	-101.146	-11.4721	-6.6436	-4.4537
$8*10^5$		-104.6211	-59.8546	-10.0399	-5.8407	-3.9247
$9*10^5$		-104.6211	-23.1294	-8.9347	-5.2164	-3.5128
$10^6$		-104.6211	-19.4081	-8.0548	-4.7168	-3.1828

REFERENCES

- [1] Reddy J. N. (2006) Theory and Analysis of Elastic Plates and Shells, Second Edition, CRC Press, P. 568.
- [2] Reissner E., (1945), The effect of transverse shear deformation on the bending of elastic plates, ASME Journal of Applied Mechanics, Vol. 12, pp. A68-77.
- [3] Mindlin R. D., (1951), Influence of rotatory inertia and shear on flexural motions of isotropic, elastic plates, ASME Journal of Applied Mechanics, Vol. 18 pp. 31-38.
- [4] Ambartsumyan S.A. (1974) General theory of anisotropic shells. M. Nauka, P.448.
- [5] Halil Ozer A comparative analysis of Mindlin and Kirchhoff bending solutions for nonlinearly tapered annular plate with free edges // Archive of Applied Mechanics, 2007, Volume 77, Issue 6, P. 393-405

- [6] Douglas N. Arnold, Alexandre L. Madureira, Sheng Zhang On the Range of Applicability of the Reissner–Mindlin and Kirchhoff–Love Plate Bending Models // *Journal of elasticity and the physical science of solids*, June 2002, Volume 67, Issue 3, P. 171–185.
- [7] Vardanyan S.V. (2005), Less concentration state near the tip of neutron irradiated compound plates for various boundary conditions // *V Mechanical engineering Mixed problems, Russian Conference with International participation, Saratov, Russia*, P. 83-87. (In Russian).
- [8] Ambartsumyan S.A., Bagdasaryan G.E., Belubekyan M.V. (1977) Magnetoelasticity of thin shells and plates. *M. Nauka*, P. 272. (In Russian).
- [9] Ambartsumyan S.A., Bagdasaryan G.E. Electro conducting plates and shells in magnetic field *M. Phys.-math. Literature*, (1996) 286. (In Russian).
- [10] Kaliski S. Magnetoelastic vibration of perfectly conducting plates and bars assuming the principal of plane sections. *Proc. Vibr. Pol. Acad. Sci.*, 3 (1962) 225-234.
- [11] Sarkisyan V.S., Sarkisyan S.V., Dzilavyan S.A., Sarkisyan A.L. Investigation of electroconducting plates in magnetic field, *Mezhvus. Sbornik nauchnikh trudov, Mechanika, Yerevan State University*, (1980) 45-30. (In Russian).
- [12] Bagdoev A.G., Movsisyan L.A. Modulation of thermomagnetoelastic waves in magnetic field. *Izv. NAS Armenia, Mechanica*, 52 (1999) 25-30. (In Russian).
- [13] Novatsky V. *Elasticity. M. Mir.* (1975) 863. (In Russian).
- [14] Bagdoev A.G., Sahakyan S.G. Stability of nonlinear modulation waves in magnetic field for space and averaged problems. *Izv. RAS MTT*, 5 (2001) 35-42.
- [15] Bagdoev A.G., Vantsyan A.A. Theoretical and experimental investigations of waves in plate in magnetic field for space and averaged problems. *Int. J. Solids & Struct.*, 39 (2002), 851-859.
- [16] Safaryan Yu.S. Investigations of vibrations of magnetoelastic plates vibrations in space and averaged treatment. *Inform. Thehnologies and managemen*, 2(2007) 17-49.
- [17] Kolski H. *Stress waves in solids. Oxford* (1953) 192.
- [18] Bagdasaryan G.E., Belubekyan M.V. Axialsymmetric vibrations of cylindrical shell in magnetic field. *Izv. AN Arm SSR, Mechanika*, 20 (1967) 21-27. (In Russian).
- [19] Bagdoev A.G., Vardanyan A.V., Vardanyan S.V. (2006) Linear bending vibrations frequencies determination in magnetoelastic cylindrical shells // *Reports of Armenian National Academy of Sciences Vol.106, № 3, Yerevan*, P. 227-237. (In Russian).
- [20] Bagdoev A.G., Vardanyan A.V., Vardanyan S.V. (2007) The Definition of linear frequencies of bending vibrations of magnetoelastic cylindrical shells by exact space treatment// *Multidiscipline Modeling in Mat. and Str.*, Vol. 3, No. 1, pp. 107-120.
- [21] Bagdoev A.G., Vardanyan A.V., Vardanyan S.V. (2007) Linear bending vibrations frequencies determination of piezoelectric plates and shells by exact space and averaged treatments // *Bulletin of Samara State University, Natural Sciences, № 2 (52), Samara*, P. 80-99.
- [22] Bagdoev A.G., Vardanyan A.V., Vardanyan S.V. (2007) Analytical and numerical investigations of nonlinear modulation waves stability in piezoelectric shells and plates by space and averaged treatment // *Problems of mechanics of deformable solid body. Dedicated to the 85th anniversary of academician of NAS RA Sergey Ambartsumyan, Yerevan*, P. 74-80.
- [23] Bagdoev A. G., Vardanyan A. V., Vardanyan S. V., Kukudzhyanov V. N. (2007) Determining Linear Vibration Frequencies of a Ferromagnetic Shell // *Mechanics of Solids*, 2007, Vol. 42, No. 5, pp. 786–795.
- [24] Bagdoev A.G., Vardanyan A.V., Vardanyan S.V. The determination of linear frequencies of bending vibrations of ferromagnetic shell by exact space treatment // *IUTAM symposium on relations of shell, plate, beam, and 3D models/ IUTAM bookseries, volume 9, 2008*, pp. 49-57.
- [25] Bagdoev A.G., Vardanyan A.V., Vardanyan S.V. (2008) Analytical and numerical definition of free vibration of piezoelectric and magnetoelastic plates and shells // *International conference, "Architecture and Buildings – applied problems". Yerevan-Jermuk*, P. 59-62. (In Russian).
- [26] Hong-Liang Dai, Ting Dai, Lei Yang Free vibration of a FGPM circular plate placed in a uniform magnetic field // *Meccanica*, 2013, 48, P. 2339-2347.
- [27] Landau L.D., Lifshitz E.M. (1960) *Electrodynamics of Continuous Media (Volume 8 of A Course of Theoretical Physics) Pergamon Press*, P. 460.