

Application Procedure for Optimized Placement of Buckling Restrained Braces in Reinforced Concrete Building Structures

S. A. Faizi, S. Yoshitomi

Abstract—The optimal design procedure of buckling restrained braces (BRBs) in reinforced concrete (RC) building structures can provide the distribution of horizontal stiffness of BRBs at each story, which minimizes story drift response of the structure under the constraint of specified total stiffness of BRBs. In this paper, a simple rule is proposed to convert continuous horizontal stiffness of BRBs into sectional sizes of BRB which are available from standardized section list assuming realistic structural design stage.

Keywords—Buckling restrained brace, building engineering, optimal damper placement, structural engineering.

I. INTRODUCTION

RC building structures are designed to satisfy a certain level of earthquake resistant requirement. However, it is concerned that, for quite severe earthquake columns, beams or slabs are damaged, and seismic story drift responses exceed the allowable limits [1]. To solve this problem, a variety of vibration control systems have been developed such as shear wall, base isolation, or dampers. Considering the case of seismic retrofitting, BRBs is a superior system to the other shear resisting devices from the point of view of construction and cost. BRB is expected to dissipate a great amount of energy and to reduce the seismic responses.

A lot of research works have been conducted about using BRB in newly-built or existing building structures. As for the fabrication of BRB, optimal length of BRB steel core is formulated analytically and tested experimentally [2]. On the other hand, there are quite few research works about practical BRB design method compared to the other types of damper systems.

A lot of methods have been proposed to determine linear viscous damper placement for building structures and these methods can be directly extended to linear brace placement. A steel brace optimization procedure is proposed based on transfer function of linear model and two different rehabilitation techniques, steel brace and viscous damper, are compared [3]. A topology optimization method is applied to obtain optimal topology of the bracing system of structures with linear material under harmonic loads [4]. In order to construct a non-linear damper design method, most of the

previous methods use linearization or simplification. An efficient procedure to determine optimal placement of nonlinear hysteretic dampers has been proposed based on design response spectrum and equivalent linearization of hysteretic model [5].

As for the design method of BRBs, a seismic retrofit design method is considered for RC buildings with elastic steel frame and BRBs in order to evaluate the amount of BRB using a simplified equivalent linearization method [6]. A simplified formulation is suggested to determine BRB ductility and strength for steel frames equipped with BRBs considering design spectra of Eurocode 8 [7]. Sensitivity analysis method has been proposed to investigate the relation between seismic performances and brace over-strength distributions as a tool for safer design of BRBs [8]. On the other hand, several methods have been suggested to consider the nonlinearity of dampers directly. A practical method is recommended for optimum design of the non-linear oil dampers with relief mechanism installed in multi-story framed building structures based on a sensitivity analysis by using nonlinear time-history response analysis [9]. A systematic methodology was proposed for determining the optimal cross sectional area of BRBs on the seismic upgrading of existing structures using genetic algorithm [10].

A simple and practical optimal placement procedure was proposed to find the optimal stiffness for BRBs to minimize the seismic story responses (drift) of the structure [11]. This procedure continuously traces the most effective placements of BRB by increasing total BRB stiffness from zero to a specified value based on nonlinear time-history analysis considering nonlinearity of BRB directly. This method provides stiffness of BRBs of each story as continuous value depending on the step length of optimization process.

In a practical design procedure, it is required to select steel members from specified standard section lists. Therefore, in this paper, a simple rule is derived to convert continuous horizontal stiffness of BRBs obtained from the previous method into standard sectional sizes of BRB. In this paper, a new practical method is proposed to determine the sectional sizes of BRBs from the result of the previously proposed method for BRB placement optimization in RC building structures.

II. TARGET MODEL WITHOUT BRB

The target model is the same as the model used in [11]. The model, as shown in Fig. 1, has been modeled in ETABS. This

S. A. Faizi, Master Student, is with the Ritsumeikan University, Shiga, CO 525-8577 Japan (phone: +8170-1749-4391; e-mail: shabirfaizi@gmail.com/gr0258ei@fc.ritsumei.ac.jp).

S. Yoshitomi Ph.D., Professor, is with the Ritsumeikan University, Shiga, 525-8577 Japan (e-mail: yositomi@fc.ritsumei.ac.jp).

model is containing five typical stories, and the structure material is RC. The height of each story is typically 3.6 m. Young's modulus of concrete for the RC structure is 2.094174×10^4 MPa. The damping ratio of the structure is assumed to be as $\xi(h) = 0.05$ which means 5% damping [10].

III. METHODOLOGY

A. Optimal BRB Placement Problem

In this chapter, the previously proposed BRB optimization procedure is introduced. The optimal BRB placement problem is how to determine the adequate BRB stiffness in order to minimize the maximum response of the structure. BRB optimization problem is defined in three equations.

$$\text{Find } X = (k_1^{BRB}, \dots, k_N^{BRB}) \quad (1)$$

$$\text{To minimize } f(X) = \max_i \delta_{imax} \quad (2)$$

$$\text{Subject to } \sum_i k_i^{BRB} = \bar{K} \quad (3)$$

where \bar{K} and k_i^{BRB} indicate total BRB stiffness and BRB stiffness of i -th story, and δ_{imax} indicates the maximum story drift response of the i -th story [10].

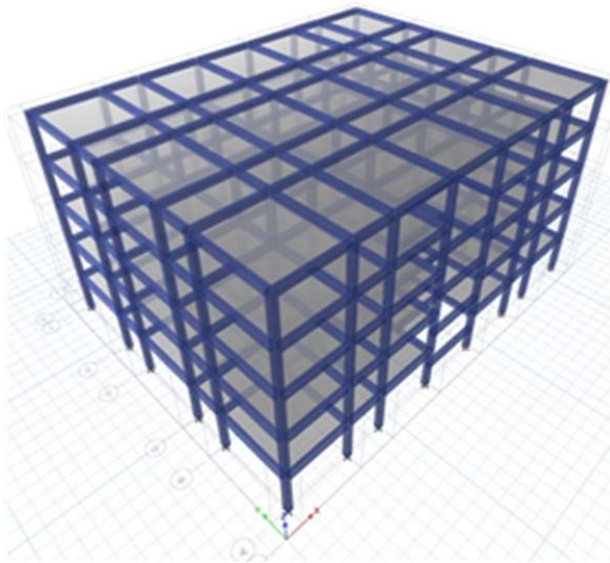
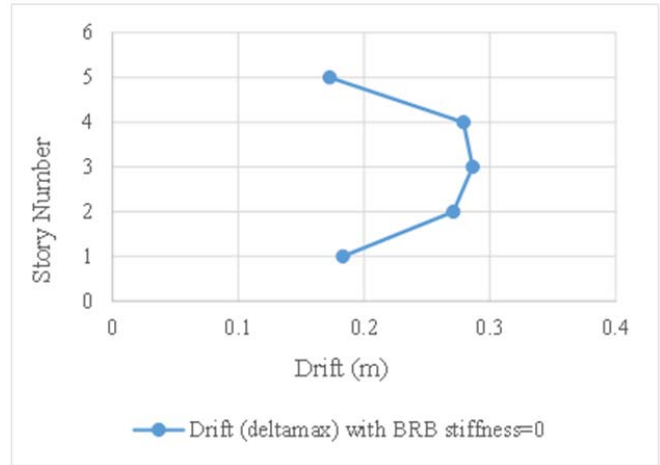

Fig. 1 RC Building 3D-view

TABLE I
 STORY MASS AND STORY STIFFNESS

Story	Mass (kg)	Stiffness (N)	Stiffness (N/m)
1	626430	6143179.77	226315592
2	624705	6126263.31	148560662
3	624705	6126263.31	138974375
4	624705	6126263.31	131338900
5	632842	6206060.02	130239362



(a) Linear direct integration, time history analysis)

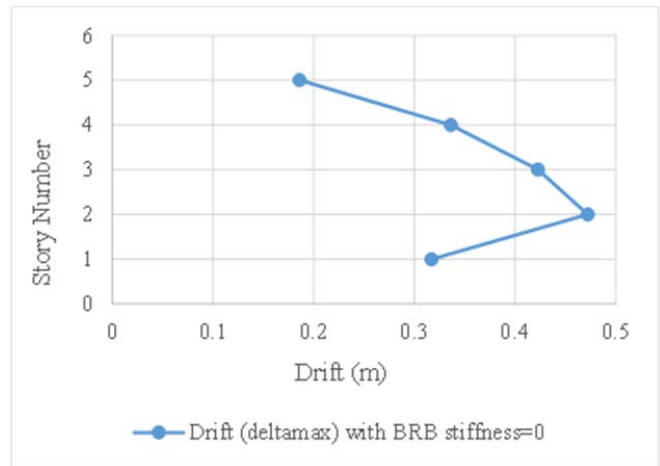

(b) Nonlinear direct integration, time history analysis)

Fig. 2 Story responses before optimization by MATLAB

B. Optimization Procedure

In order to solve the optimization problem described in the previous section, a simple algorithm is proposed in this section. This procedure continuously traces the most effective placements of BRB by increasing total BRB stiffness from zero. The proposed method is summarized in five steps.

- (1) Consider N-story shear building model and set the yield displacements of the structure and BRB and the incremental stiffness of the BRB Δk .
- (2) Consider N candidate models. As for the i -th candidate model, BRB with stiffness Δk is added to the i -th story of the model with optimal BRBs obtained in the previous optimization step.
- (3) Compute the time-history responses of the N candidate models in (2) for input ground acceleration and evaluate the maximum response as an objective function.
- (4) Find the candidate model with the lowest objective function among the N candidate models.
- (5) Update the stiffness of BRBs and return to (2) until the total stiffness of BRBs reaches to the specified value.

The most characteristic point of the proposed method is that

this procedure needs only N candidate models at every optimization step which is equal to the number of the story. Fig. 3 shows the detailed sample of three optimization steps. At every optimization step, only five candidate models are compared with respect to the maximum drift response. In the first optimization step, each of the five candidate models has BRB with stiffness Δk in the different story. In this case, candidate model 1 is selected as an optimal BRB placement at the first optimization step. In the second optimization step, each of the five candidate models has additive BRB with stiffness Δk in the different story to the optimal BRB placement at 1st optimization step. In this case, candidate model 3 is selected as an optimal BRB placement among in the second optimization step. These steps are continued until we find the optimal placement [11].

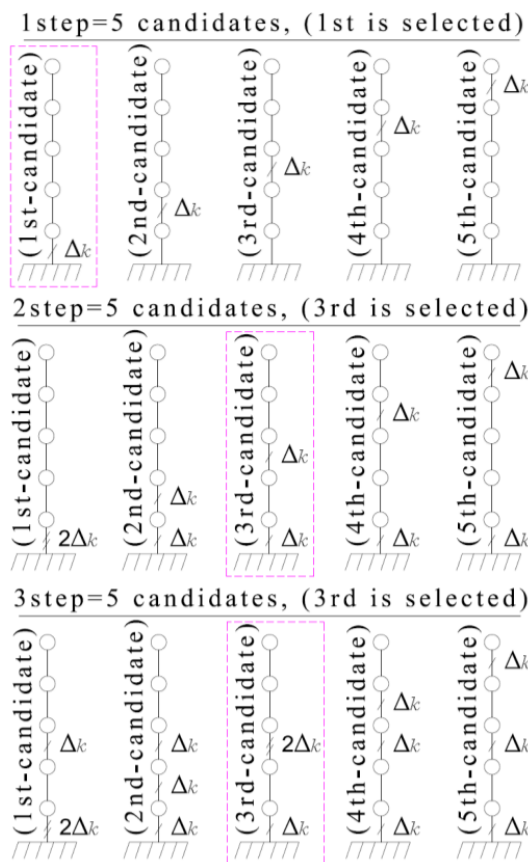

Fig. 3 Schematic model for BRB placement

C. Application of the Optimized Stiffness of the BRBs

In a practical structural design stage, steel members are selected from standard section lists with specified section sizes. Therefore, in this section, a simple rule is derived to convert continuous horizontal stiffness of BRBs obtained by the previous method into standard sectional sizes of BRB.

- (1) Change the optimized stiffness of BRBs into the form of sectional area. The optimized stiffness of BRBs from the last step of the selected candidate has continuous value depending on the step length of optimization process. To change the optimized stiffness of BRBs into the form of

sectional area, we have to follow the procedures according to Fig. 4.

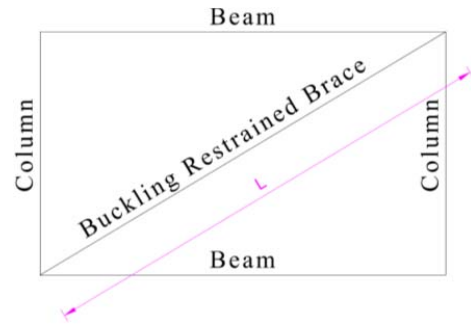

(a) Normal model without Earthquake force

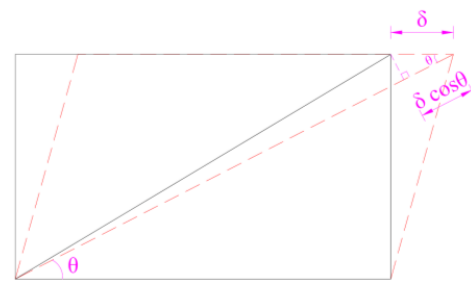

(b) Displaced model by earthquake force

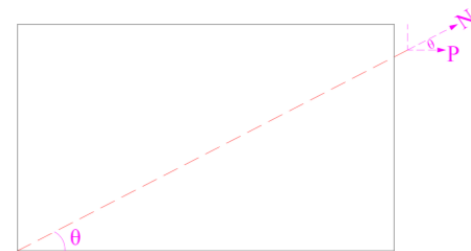

(c) BRB absorbing earthquake force

Fig. 4 State of model of the structure before and during earthquake with BRB

Form Fig. 4 we can get K .

$$\epsilon = \frac{\Delta l}{L}$$

$$\epsilon = \frac{\delta \cos(\theta)}{L}$$

$$N = EA\epsilon = EA \frac{\delta \cos(\theta)}{L}$$

$$P = N \cos(\theta) = \frac{EA \delta \cos^2(\theta)}{L}$$

$$K = \frac{P}{\delta} = \frac{EA \cos^2(\theta)}{L} = \frac{Eab \cos^2(\theta)}{L}$$

where, ϵ : Strain; Δl : Elongation of BRB; L : real length of BRB in normal model; δ : Displacement of the structure as drift; θ : Angle between BRB and beam; N : axial force of BRB; $E=29000\text{ksi}$: modulus of elasticity of the steel for BRB;

$A=a*b$: cross sectional area of the steel for BRB with thickness a and width b ; P : horizontal force (earthquake force); K : stiffness of a brace with specified sectional sizes.

When the sectional sizes of BRB, i.e. a and b , are specified, the horizontal stiffness of one BRB (K_{BRB}) can be evaluated from the formulation resulted in Fig. 4 as $K_{BRB}=E \times a \times b \times \cos^2(\theta)/L$. The necessary number of BRB of each story can be obtained by dividing the optimized BRB stiffness of each story by K_{BRB}

$$N_{BRBi}=K_{BRBi}/K_{BRB}$$

where, N_{BRBi} is the number of BRB in i -th floor, K_{BRBi} is the total stiffness needed for BRB in i -th floor from the last optimization step.

In the case that the number of BRBs does not have integer value, it should be rounded to integer number. In general, it is desirable to select the nearest integer number.

- (2) Compare the response of the structure into three cases that the second and third cases should have almost the same result.
- Case 1: model without BRBs.
 - Case 2: model with the optimized stiffness of the BRBs.
 - Case 3: model with the modified optimized stiffness of the BRBs corresponding to the integer number of the BRBs.

IV. NUMERICAL EXAMPLES

In this section, we are calculating the exact number of BRBs. Fig. 5 and Table II show the optimized placement of BRBs with their stiffness considering the last optimization step of 250 steps. Yielding displacements of building structure and BRB are set as $\delta_{ys}=0.01m$ and $\delta_{yd}=0.007m$, respectively [11].

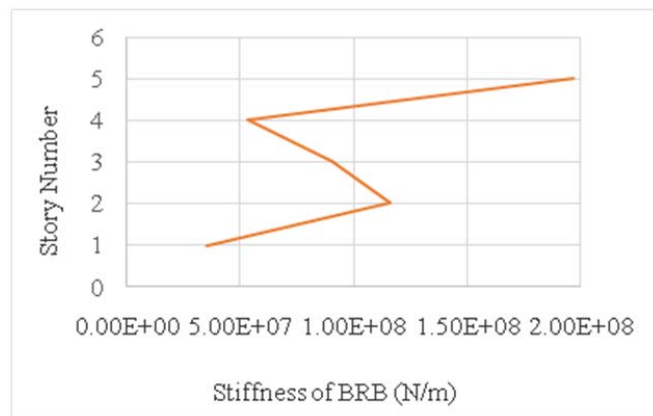

Fig. 5 Optimized stiffness of BRBs (last optimization step of 250 steps)

The θ and L can be known from the dimensions of Fig. 6 as:

$$\theta = \tan^{-1}\left(\frac{3.6m}{6m}\right) = 30.964^\circ$$

$$\cos^2 = \frac{1}{2} + \frac{1}{2}\cos(2\theta) = \frac{1}{2} + \frac{1}{2}\cos(61.928^\circ) = \frac{1}{2} + \frac{1}{2} * 0.471 = 0.735$$

$$L = \sqrt{(3.6)^2 + (6)^2} = 6.997m$$

The stiffness of one BRB can be calculated as shown in Table III for a desired cross sectional area ($A=1 \text{ cm} \times 1.2 \text{ cm}=0.0012 \text{ m}^2$). Here, $E_s=29000 \text{ ksi} = 1.9995760 \times 10^{11} \text{ N/m}^2$. The optimized number of BRBs in each floor can be obtained as shown in Table IV by dividing optimized BRB stiffness in Table II by K_{BRB} . These real numbers are rounded into integer numbers. The modified BRBs stiffness corresponding to the integer numbers is shown in Table IV.

TABLE II
OPTIMIZED STIFFNESS OF BRBs (LAST OPTIMIZATION STEP OF 250 STEPS)

Story	Optimized stiffness of BRBs (N/m)	Stiffness of structure according to Table I (N/m)
1	35429824.62	226315592.45
2	116131091.81	148560662.30
3	90542885.14	138974375.92
4	53144736.93	131338900.74
5	196832359.00	130239362.10

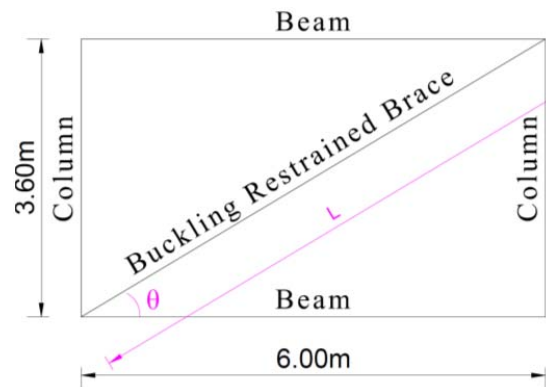

Fig. 6 Dimensions of the braced frame

TABLE III
1 KBRB CALCULATIONS, BRB AREA= (1*12) CM²

Items	Units	Values
One BRB area (A)	m ²	0.0012
Modulus of elasticity of the steel for BRB(E)	N/m ²	199957597569.9800
θ	degree	30.9640
Length of BRB (L)	m	6.9970
K_{BRB} (one BRB's stiffness) = $A * E * \cos^2(\theta) / L$	N/m	25205459.6337

TABLE IV
MODIFIED OPTIMIZED STIFFNESS OF BRBs

Story	Total optimized number of BRBs = optimized stiffness of BRBs/1KBRB	Selected exact number of BRBs	Modified optimized stiffness of BRBs (N/m) = selected exact number of BRBs*1KBRB
1	1.39	2.00	50821710.64
2	4.57	5.00	127054276.60
3	3.56	4.00	101643421.28
4	2.09	2.00	50821710.64
5	7.75	8.00	203286842.56

V. RESULT

Table V and Fig. 7 show the comparisons of the maximum

story drifts among the three models, i.e. model without BRB, model with optimized BRB stiffness in Table II, and model with modified optimized BRB stiffness in Table IV. From Fig. 7 it can be understood that the responses due to modified optimized stiffness of BRBs are almost the same as responses of optimized stiffness of BRBs, and both of them can decrease the maximum responses effectively.

TABLE V
SEISMIC STORY DRIFT RESPONSES OF THE STRUCTURE INTO THREE CASES

Story	Drift (deltamax) with BRB stiffness=0	Drift (deltamax) with BRB stiffness =Optimized	Drift (deltamax) with BRB stiffness =Modified optimized
	M	m	m
1	0.014	0.024	0.022
2	0.029	0.025	0.025
3	0.028	0.025	0.026
4	0.026	0.024	0.024
5	0.012	0.005	0.005

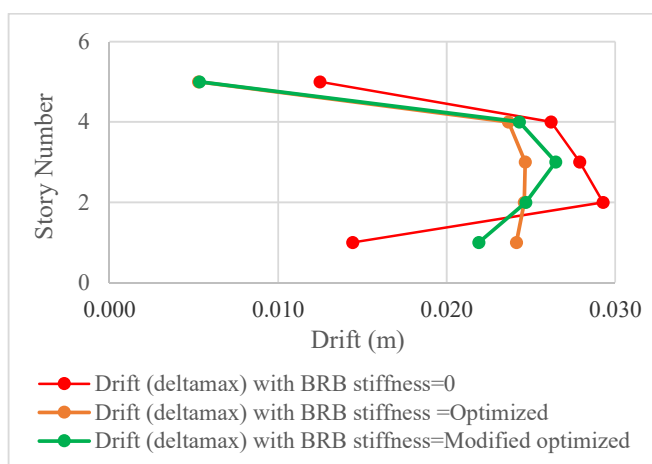

Fig. 7 Seismic story drift responses of the structure into three cases (nonlinear direct integration, time history analysis by MATLAB)

VI. CONCLUSION

A new practical procedure is proposed to determine the sectional sizes of BRBs from the result of the previously proposed method for BRB placement optimization in RC building structures, which minimizes the seismic response drifts, so three conclusions have been derived.

- (1) Considering the practical structural design stage, a formulation is derived to convert the optimized BRB stiffness with real number into the integer number of BRB with sectional sizes selected from standardized section list.
- (2) The validity of the proposed method is demonstrated through numerical examples of five storied building structures.
- (3) The comparisons of the maximum story drifts have been conducted among three models, i.e. model without BRB, model with optimized number of BRBs as real number and model with modified optimized number of BRBs as integer number. From the results, it is demonstrated that the responses due to modified optimized stiffness of BRBs are

almost the same as responses of optimized stiffness of BRBs, and both of them can decrease the maximum responses effectively.

REFERENCES

- [1] Minimum Design Loads for Buildings and Other Structures, ASCE 7-05, chapter.12
- [2] Mirtaheri, M., Gheidi, A., Zandi, A. P., Alanjari, P., and Samani, H. R.: Experimental optimization studies on steel core lengths in buckling restrained braces, *Journal of Constructional Steel Research*, ELSEVIER, Vol.67, 2011, pp.1244-1253.
- [3] Aydin, E. and Boduroglu, M. H.: Optimal placement of steel diagonal braces for upgrading the seismic capacity of existing structures and its comparison with optimal dampers, *Journal of Constructional Steel Research*, ELSEVIER, Vol.64, 2008, pp.72-86.
- [4] Allahdadian, S., Boroomand, B., and Barekatein, A. R.: Towards optimal design of bracing system of multi-story structures under harmonic base excitation a topology optimization scheme, *Finite Elements in Analysis and Design*, ELSEVIER, Vol.61, 2012, pp.60-74.
- [5] Martinez, C. A., Curadelli, O., and Compagnoni, M. E.: Optimal placement of nonlinear hysteretic dampers on planar structures under seismic excitation, *Engineering Structures*, ELSEVIER, Vol. 65, 2014, pp.89-98.
- [6] Sutcu, F., Takeuchi, T., and Matsui, R.: Seismic retrofit design method for RC buildings using buckling-restrained braces and steel frames, *Journal of Constructional Steel Research*, ELSEVIER, Vol.101, 2014, pp.304-313.
- [7] Bosco, M., Marino, E.M., and Rossi, P.P.: Design of steel frames equipped with BRBs in the framework of Eurocode8, *Journal of Constructional Steel Research*, ELSEVIER, Vol.113, 2015, pp.43-57.
- [8] Zona, A., Ragni, L., and Dall'Asta, A.: Sensitivity-based study of the influence of brace over-strength distributions on the seismic response of steel frames with BRBs, *Engineering Structures*, ELSEVIER, Vol.37, 2012, pp.179-192.
- [9] Adachi, F., Yoshitomi, S., Tsuji, M., and Takewaki, I.: Nonlinear optimal oil damper in seismically controlled multi-story building frame, *Soil Dynamics and Earthquake Engineering*, ELSEVIER, Vol.44, 2013, pp.1-13.
- [10] Farhat, F., Nakamura, S., and Takahashi, K.: Application of genetic algorithm to optimization of buckling restrained braces for seismic upgrading of existing structures, *Computers and Structures*, ELSEVIER, Vol.87, 2009, pp.110-119.
- [11] S., A. Faizi. and S. Yoshitomi: Optimal placement of buckling restrained braces in reinforced concrete building structures, proceedings of JAEE annual meeting 2016.