

# Performance of Derna Steam Power Plant at Varying Super-Heater Operating Conditions Based on Exergy

Idris Elfeituri

**Abstract**—In the current study, energy and exergy analysis of a 65 MW steam power plant was carried out. This study investigated the effect of variations of overall conductance of the super heater on the performance of an existing steam power plant located in Derna, Libya. The performance of the power plant was estimated by a mathematical modelling which considers the off-design operating conditions of each component. A fully interactive computer program based on the mass, energy and exergy balance equations has been developed. The maximum exergy destruction has been found in the steam generation unit. A 50% reduction in the design value of overall conductance of the super heater has been achieved, which accordingly decreases the amount of the net electrical power that would be generated by at least 13 MW, as well as the overall plant exergy efficiency by at least 6.4%, and at the same time that would cause an increase of the total exergy destruction by at least 14 MW. The achieved results showed that the super heater design and operating conditions play an important role on the thermodynamics performance and the fuel utilization of the power plant. Moreover, these considerations are very useful in the process of the decision that should be taken at the occasions of deciding whether to replace or renovate the super heater of the power plant

**Keywords**—Exergy, super-heater, fouling, steam power plant, off-design.

## I. INTRODUCTION

IN the conventional thermal cycle analysis, the performances of a power plant are usually determined by its thermal efficiency, where higher efficiency implies better thermodynamics performance. Power plant cycles are often faced with the problems of assessing the change in operating costs due to deterioration of performance of individual pieces of equipment, and the predicting of the effect on performance due to changes in equipment or operating procedures. The fossil-fueled Derna steam power plant (D-SPP) is designed with an overall thermal efficiency of 32% [1]. Currently, the plant operates with the lowest efficiency. It is expected that the main reason for the efficiency loss is due to the reduction in the top temperature due to the deterioration of the super heater performance, and hence, the reduction in the overall temperature difference between the hot gases and the working steam. The main role of the super heater is to play the performance of SPP and it increases plant efficiency by increasing the average temperature ( $T_{\text{recipient}}$ ) at which heat is supplied to the cycle from products of combustion [2]. Therefore, the useful energy (exergy) consumption for driving

heat transfer processes increases with ( $T_{\text{source}}-T_{\text{recipient}}$ ); super heater increases the power plant efficiency by decreasing this difference [2]. The super heater performance is decreased by decreasing its overall thermal conductance (UA). This variation in the overall thermal conductance may result from:

- i- Reduction in super heater surface area (A) due to performance deteriorates and leaks invariably occur. In order to restore the super heater functioning properly, the leaking tubes are plugged to keep them out of service and thereby reducing the super heater surface area.
- ii- Reduction in overall heat transfer coefficient (U) due to fouling (deposits) on heat transfer surfaces of the super heater' tubes.

These changes cause decrease in the overall conductance of the super heater to the point where the super heater can no longer operate near the design condition. As the super heater efficiency drops off, it affects the overall cycle efficiency, which causes an increase in operating costs. This is due to the additional fuel supply in the boiler to bring the turbine-driving steam temperature up to the design value. If the additional fuel cannot be supplied to the boiler, to avoid the furnace tube overheating due to excessive flue gases temperature, the steam temperature will be below the design value. At certain stage, the deterioration of super heater performance becomes so great that the super heater should be taken out of service for cleaning or replacement. Moreover, as the overall conductance (UA) decreases, the amount of heat transfer decreases, which causes a reduction in the steam outlet temperature. The rate of heat transfer between the flue gases and steam decreases, the exergy destruction increases due to the irreversibility of the heat transfer process. Therefore, the electrical power and the overall performance of the plant decrease.

The exergetic approach to reducing energy consumption in thermal power plants was used by several authors. Gaggioli and Fehring [3] carried out detailed exergy analysis for a 350 MW SPP and investigated the effect of the boiler inlet feedwater temperature on the unit operating cost. Lior [4] conducted a thermo-economic and exergy analysis of the effects of fossil-fuel superheating in a nuclear power plant. Benyo et al. [5] introduced a simulation model to describe the thermal process of a single steam super heater stage. An energy-exergy analysis of a coal-base thermal power plant was reported by Suresh et al. [6], using the design data from a 63 MWe plant under operation. Srinivas et al. [7] examined the improvements in efficiency with increase in boiler pressure, turbine inlet temperature and furnace temperature on the basis of exergy analysis. Different ways of enhancing the performance of SPPs were presented by Bhatt and Rajkumar

Idris Elfeituri is with the Department of Mechanical Engineering, University of Benghazi, Benghazi City, P.O.Box: 32834Libya (phone: +218-94-471-0641; e-mail: idrisffff@yahoo.com).

[8]. Moreover, Rosen and Raymond [9] carried out energy and exergy analysis for a SPP and evaluated possible modifications to improve the efficiency of the plant, as well as, Szargut [10] and Elfeituri [11] performed the first and second law analysis of the influence of regenerative feedwater heaters operation conditions on the thermodynamic performance of the steam power plants.

In current study, 65 MW SPP is modeled, analyzed and the effect of the varying super heater operating conditions are investigated.

## II. POWER PLANT DESCRIPTION

D-SPP was designed and built in 1980 by BBC at Derna-Libya [1]. A detailed process flow-diagram of the plant is shown in Fig. 1, with three stages of extraction to the regenerative feedwater heating system. Feedwater heating is carried out in one stage of low pressure heater (LPH) and one stage of high pressure heater (HPH) along with one open heater, Deaerator (DA). A saturated steam from the boiler drum is fed to the super heater (SH) and that elevates the heat to 520 °C at a pressure of 87 bar. The super heater has a total surface area of 2035 m<sup>2</sup> and heat transferred rate of 58.2 MW [1]. The flue gases with high temperature pass through the super heater, evaporator, economizer and air heater sections and finally exit to the surrounding through the stack. The extraction pressures at the design conditions of steams (in bar) from the turbine are as:

- High pressure heater (HPH): 21.8
- Low pressure heater (LPH): 1.15
- De-aerator (DA): 6.03
- Condenser (CND): 0.07

This study is based on the off-design conditions with the following assumptions:

- i- In order to calculate exergy flow rate, the reference ambient conditions were taken as 1.0131 bar and 25 °C, respectively.
- ii- The maximum flue gases temperature ( $T_3$ ): 1300 °C.
- iii- The maximum steam temperature at the super heater outlet ( $T_2$ ): 520 °C.
- iv- The amount of energy supplied by the fuel to the boiler ( $Q_{f,o}$ ): 195.4 MW.
- v- The heavy fuel oil is used with LHV of 44MJ/kg.
- vi- The steam generated in the boiler ( $m_1$ ): 67.46 kg/s.
- vii- The design value of overall conductance of the super heater (UA): 48. kW/K [1].
- viii- The maximum reduction in the overall conductance (UA): 50% of the design value.
- ix- The feedwater temperature, pressure and flow rate at the boiler inlet are constant.
- x- Dry saturated steam with constant enthalpy is supplied to the super heater.
- xi- The parasitic power consumption by the plant equals the pumping power requirement only (condenser extraction pump, cooling water pump and boiler feedwater pump).

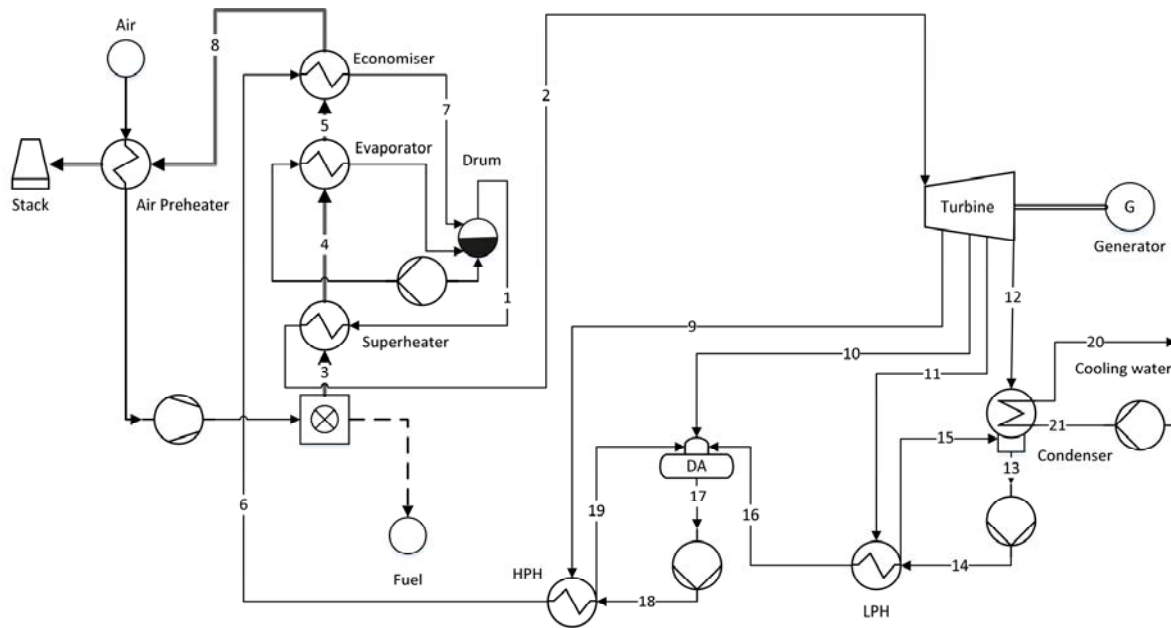

Fig. 1 Schematic diagram of D-SPP

The power plant flow diagram is shown in Fig. 1. The mathematical model takes into account the off-design operating conditions for the whole thermal system. The off-design condition is the result of the change of steam temperature ( $T_2$ ) at the super heater outlet. The off-design condition is accomplished by reducing the super heater overall conductance (UA). The energy supplied by fuel ( $Q_f$ ), boiler

inlet feedwater temperature ( $T_6$ ), steam output pressure ( $p_2$ ) and flow rate ( $m_2$ ) are kept constant.

The detailed equations are not presented here in view of brevity. The problem is attempted by means of a general method of defining the state of thermal system at off-design operating conditions. With regard of Fig. 1, each component in the power plant was considered as a control volume and

analyzed separately. Three balance equations were written for each component including mass, energy and exergy. The basic balance equations are;

$$\text{For mass; } \sum m_{in} - \sum m_{out} = 0.0 \quad (1)$$

$$\text{Energy; } \sum m_{in} h_{in} - \sum m_{out} h_{out} + \sum Q_{in} - \sum Q_{out} + \sum P_{in} - \sum P_{out} = 0.0 \quad (2)$$

$$\text{Exergy; } \sum EX_{in} - \sum EX_{out} + \sum P_{in} - \sum P_{out} - EXD = 0.0 \quad (3)$$

#### A. Steam Boiler Model

The first law efficiency of the boiler is obtained from performance test data of the considered plant [1]. The curve fitting was used to obtain an equation for calculating the boiler efficiency at varying boiler heat capacity. The equation is as:

$$\eta_B = \eta_{B,o} \left[ a + b \left( \frac{Q_B}{Q_{B,o}} \right) + c \left( \frac{Q_B}{Q_{B,o}} \right)^2 + d \left( \frac{Q_B}{Q_{B,o}} \right)^3 \right] \quad (4)$$

where  $Q_B$  and  $Q_{B,o}$  are the boiler heat capacity at design and off design conditions respectively, coefficients:  $a=0.263$ ,  $b=2.5$ ,  $c=2.5$  and  $d=0.654$

#### B. Superheater Model

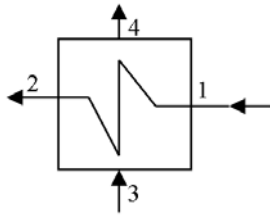

Fig. 2 Schematic diagram of the super heater: 1-saturated steam inlet, 2-superheat steam outlet, 3-hot gases inlet, 4- hot gases outlet

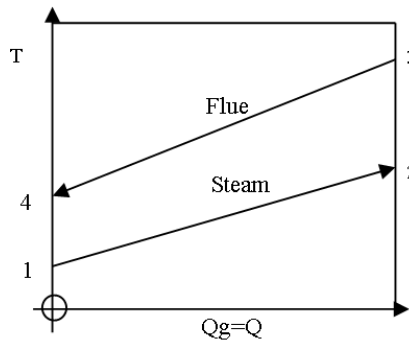

Fig. 3 Temperature distribution in the super heater

The schematic diagram of the super heater and its temperature distribution are shown in Figs. 2 and 3, which is a counter-flow type of super heater. For the given relative change ( $k$ ) in the super heater overall conductance ( $UA$ ), the task of the super heater model is to calculate the outlet temperatures for steam ( $T_2$ ) and flue gases ( $T_4$ ). The superheater model may be written as: The super heater effectiveness  $\varepsilon$  is defined as the ratio of the actual rate of heat

transfer in a given super heater to the maximum possible rate of exchange, and is given by [12]:

$$\varepsilon = \frac{1 - \exp[-NTU(1-R)]}{1-R} = \frac{(T_2 - T_1)}{(T_3 - T_1)} \quad (5)$$

where  $R$  is the ratio of the heat capacity rates of the hot and cold streams, and is expressed as

$$R = \frac{m_s C_{p,s}}{m_g C_{p,g}} = \frac{(T_3 - T_4)}{(T_2 - T_1)} \quad (6)$$

and  $NTU$  is the number of transfer units and is given as

$$NTU = \frac{UA}{m_s C_{p,s}} = \frac{(T_2 - T_1)}{LMTD} \quad (7)$$

where,  $LMTD$  is the log-mean temperature difference and is calculated from

$$LMTD = \frac{(T_3 - T_2) - (T_4 - T_1)}{\ln \frac{(T_3 - T_2)}{(T_4 - T_1)}} \quad (8)$$

The relative change ( $k$ ) is defined as the ratio of the actual value ( $UA$ ) to the design value ( $UA_0$ ) of overall conductance in the super heater and is given by:

$$k = \frac{UA}{UA_0} \quad (9)$$

The method of number of transfer units has been introduced for super heater, to solve for the two unknown outlet temperatures  $T_2$  and  $T_4$ . The flue gases ( $Q_g$ ) and steam sides ( $Q_s$ ) heat transfer rates may now be calculated through:

$$Q_g = m_g C_{p,g} (T_3 - T_4) \quad (10)$$

and

$$Q_s = m_s C_{p,s} (T_2 - T_1) \quad (11)$$

#### C. Power Plant Performance Model

The overall energy efficiency of the power plant is defined as

$$\eta_l = \left( \frac{P_{net}}{Q_f} \right) * 100\% \quad (12)$$

$$P_{gross} = \eta_{Gen} * P_m \quad (13)$$

$$P_{net} = P_{gross} - P_{par} \quad (14)$$

where,  $P_{gross}$  and  $P_{net}$  are the gross and net electrical power produced respectively,  $P_{par}$  is the parasitic electrical power required to drive the water pumps, and  $Q_f$  is the total amount

of energy supplied by the fuel to the boiler at given super heater condition, and is equal to:

$$Q_f = Q_{f,o} + Q_{f,add} \quad (15)$$

The value of  $Q_{f,o}$  at design condition equals to 195.4 MW and considered as a constant through the calculations of the present study. While,  $Q_{add}$  is the additional amount of fuel energy supplied to the boiler when the super heater is in deterioration condition, it was assumed as zero in this analysis. If, the additional fuel supply is considered, then:

$$Q_{f,add} = \frac{m_s * C_{p,s} (T_{4,o} - T_4)}{\eta_B} \quad (16)$$

where  $T_{4,o}$ ,  $T_4$  are the live steam temperature at design and off-design conditions respectively, and  $C_{p,s}$  is the specific heat of steam generated. The additional mass of fuel required may be calculated as:

$$m_{f,add} = \frac{Q_{f,add}}{LHV} \quad (17)$$

The exergy balance applied to the considered power plant is described in [2]. The system turbine and pumps shaft power and electrical energy are full transfers of exergy. The exergy destruction rate ( $EXD_i$ ) in  $i$ th component is based on the exergy balance for incoming and outgoing exergy flow rates as:

$$EXD_i = \sum EX_{in} - \sum EX_{out} \quad (18)$$

Therefore, the total exergy destruction rate ( $EXDT$ ) of the whole power plant is given by:

$$EXDT = \sum EXD_i \quad (19)$$

The physical exergy flow rate ( $EX_i$ ) for any mass flow (water or steam) is calculated from [2]:

$$EX_i = m_i [ (h_i - h_o) - T_o (s_i - s_o) ] \quad (20)$$

The overall exergy efficiency (second-law efficiency) of the power plant can be found by:

$$\eta_{II} = \left( \frac{EX_{recovered}}{EX_{supplied}} = 1 - \frac{EX_{destroyed}}{EX_{supplied}} = \frac{P_{net}}{EX_f} \right) \times 100\% \quad (21)$$

The fuel exergy input ( $EX_f$ ) is calculated from [2]:

$$EX_f = \phi \times m_f \times LHV \quad (22)$$

where,  $\phi$  is taken as 1.064.

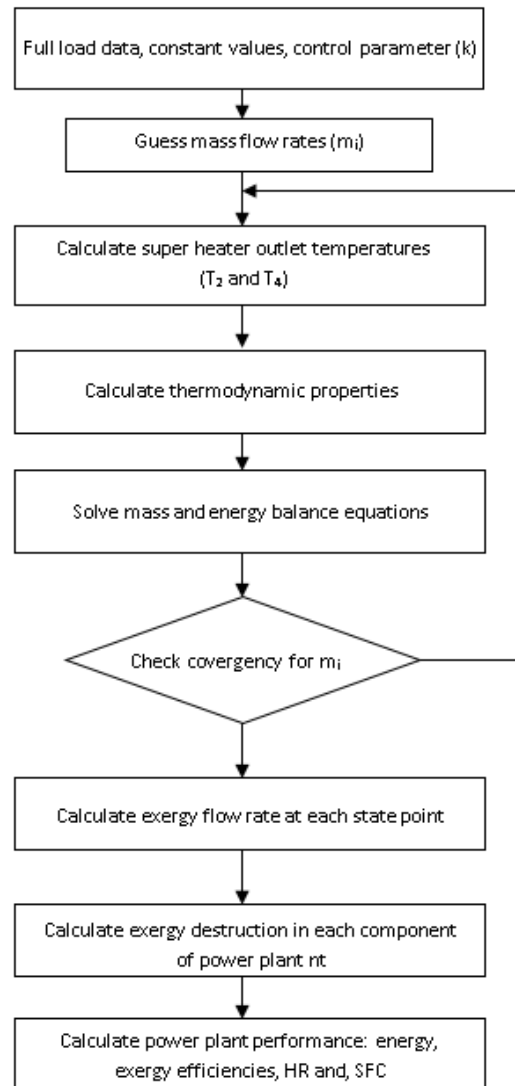

Fig. 4 Flow chart of computing steps

#### D. Analysis Procedure

The appropriate model analysis is used to carry out the influence of changes in the super heater overall conductance (UA) on the electrical power output of the SPP and the changes of exergy destruction rate in the particular component of the power plant. The model consists of the mass-energy balance equations, and equations involving thermodynamic parameters and plant performance. A computer program for the energy and exergy analysis has been written to simulate the thermodynamic performance of the considered power plant. The computational procedure is outlined in the flow chart of the program shown in Fig. 2. To perform its simulation, the main program consisting of subroutines, which consider the off-design operating conditions for the power plant components, as boiler, turbine stages, condenser, feedwater heaters and pumps. Using the full load data, the relative change of the super heater overall conductance (k), and the mathematical models for the components of the power

plant as discussed in the previous section, one can get the thermodynamic properties and mass and energy flow rates at each state point in Fig. 1. These steps are repeated until the solution reaches the required accuracy. The exergy flow rate at each state point and the exergy destruction in each component, the overall energy and exergy efficiencies, heat rate and specific fuel consumption of the power plant are then calculated.

### III. RESULTS AND DISCUSSION

The constructed computer program for this analysis has been used to study the effect of the super heater operating conditions (reduction in overall conductance) on SPP performance. The effect of the super heater operating conditions is studied on the basis of relative change of super heater overall conductance ( $k$ ) from 1.0 to 0.5. In this analysis, the value of energy supplied by fuel ( $Q_f$ ) is taken as constant and equals 195.4 MW. The obtained results are represented in graphical form through Figs. 5-10.

Fig. 5 shows the steam temperature at various relative changes of the overall conductance ( $k$ ). The increase of the relative change ( $k$ ) increases the steam temperature ( $T_1$ ). It shows that, when the relative change ( $k$ ) increases from 0.5 to 1.0, the steam temperature increases from 390 to 520 °C. Therefore, the obtained temperature difference is about 130 °C for the overall conductance reduction of a 50% from the design value.

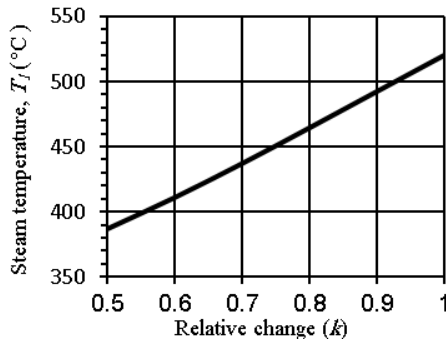

Fig. 5 Relative Change of Overall Conductance vs Steam Temperature

The effect of overall conductance variation on total exergy destruction and in major components of the plant is shown in Fig. 6. The analysis shows an increase in exergy destruction with decrease in overall conductance. The dominant exergy destruction takes place in steam boiler unit on account of carrying out combustion and heat transfer processes with a large temperature difference. Moreover, the decreasing trend of the exergy destruction may be noticed in the turbine which may be due to the decrease in turbine capacity. The feed water heaters and condenser, however, have no variations in the exergy destruction. This may be attributed to the constant heat transfer rate through this equipment due to the changes in the super heater overall conductance.

The variation of heat rate, specific fuel consumption and electrical power output with overall conductance are

illustrated in Figs. 7, 8 and 9 respectively. The decrease in overall conductance increases heat rate and specific fuel consumption and decreases the electrical power output values. The change in these values is attributed to the decrease in the enthalpy of steam at the turbine inlet and the increase in exergy destruction in the steam boiler unit.

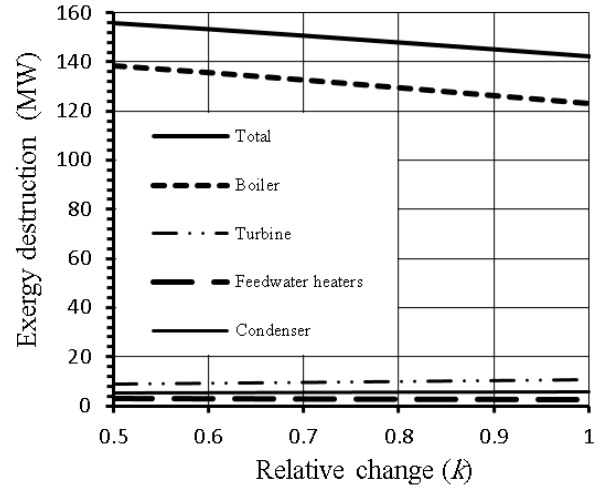

Fig. 6 Relative Change of Overall Conductance Vs Exergy Destruction in Plant Components

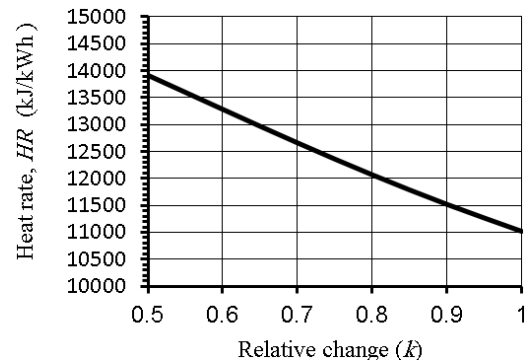

Fig. 7 Relative Change of Overall Conductance Vs. Heat Rate

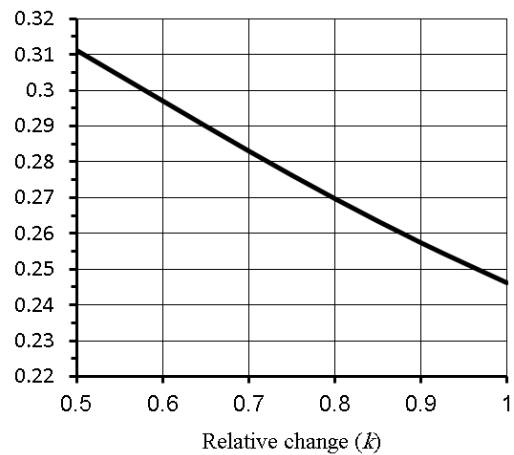

Fig. 8 Relative Change of Overall Conductance Vs. SFC

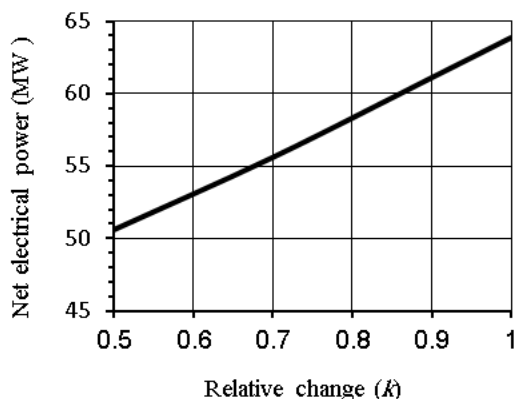

Fig. 9 Relative Change of Overall Conductance Vs. Net Electrical Power

Finally, the variation of overall energy and exergy efficiencies with the change in overall conductance is shown in Fig. 10. The overall energy and exergy efficiencies decrease by 6.8% and 6.4% respectively, when the super heater overall conductance decreases by 50%. The decrease in the overall energy efficiency can be accounted to the decrease in the turbine output power, whereas the decrease in overall exergy efficiency is attributed to the increase in exergy destruction in the steam boiler unit.

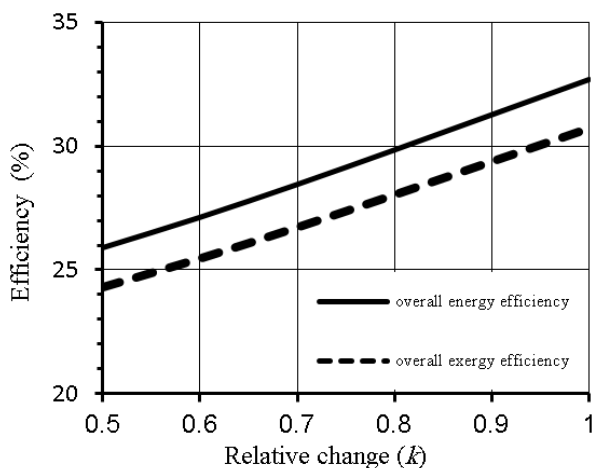

Fig. 10 Relative Change of Overall Conductance Vs Overall Energy and Exergy Efficiencies

#### IV. CONCLUSION AND RECOMMENDATIONS

In the present work, an energy-exergy based thermodynamic analysis of D-SPP has been carried out. The analysis has included the exergy destruction in the components of the power plant and assessment of the effect of super heater operating conditions, under design as well as deteriorated conditions on the plant performance. The results lead to the following conclusion:

1. The steam temperature, total exergy destruction rate, net power output, energy and exergy efficiencies decrease, while the heat rate and specific fuel consumption increase with decrease in the overall conductance of the super heater.

2. The maximum exergy destruction rate was found in the steam boiler unite.
3. The total exergy destructions of the power plant with deteriorated super heater operating condition reach the value of around 14 MW.
4. The off-design calculations resulted in an overall exergy efficiency and net power output of 24.3% and 50.56 MWe respectively, at 50% reduction in super heater overall conductance compared to 30.7% and 63.87 MWe at design condition.
5. The analysis results are expected to be beneficial to the researchers and engineers working in the area of thermal power plants. They show that super heater design and operating conditions have an important influence on the performance and the fuel utilization of the power plant, as well as, its usefulness on the decision making process during planning or renovation period, or replacement of super heater.

In future, the current results will be followed by the economic justification (operating and additional fuel costs) of super heater replacement. Moreover, the impacts of exhaust gases that are affecting the environment surroundings have to be analyzed.

#### ACKNOWLEDGMENTS

The author is grateful to Mr. *Ali Amer* for supplying the operation data and his technical advice.

#### REFERENCES

- [1] Derna Power Plant Working Documents, 1980, Turbine and Boiler Units, Brown Boveri, Vol. 4.
- [2] Szargut, J., Morris, R., and Steward, F., 1988, Exergy Analysis of Thermal, Chemical and Metallurgical Processes, First Edition, Hemisphere Publishing, New York.
- [3] Gaggioli, R., and Fehring T., 1977, "Economics of feedwater Heater replacement," ASMA Journal of Engineering for Power, Vol. 112, pp. 482-489.
- [4] Lior, N., 1996, "Energy, Exergy and Thermo-economic Analysis of the Effects of Fossil-Fuel Superheating in Nuclear Power plant," ECOS, Stockholm, pp. 669-674.
- [5] Benyo, I., et al., 2004, "Modelling of Steam Temperature Dynamics of a Superheater," Proceeding 16th European Simulation Symposium, Finland, pp. 286-290.
- [6] Suresh, M., et al., 2004, "Energy and Exergy Based Thermodynamic Analysis of a 62.5 MWe Coal-Based Thermal Power Plant- A Case Study," Int. Conference on Energy and Environment, Malaysia, pp. 1-6.
- [7] Srinivas, T. et al., 2007, "Generalized Thermodynamic analysis of Steam Power Cycles with 'n' Number of Feedwater Heaters," Int. J. of Thermodynamics, Vol. 10, pp. 177-185.
- [8] Bhatt, M. and Rajkumar, N., 1999, "Performance Enhancement in Coal Fired Thermal Power Plants, Part II: Steam Turbines, Int. J. of Energy Research, Vol. 23, pp. 489-515.
- [9] Ronsen, M. and Raymond, T., 2006, "Assessing and Improving the Efficiencies of a Steam Power Plant using Exergy Analysis part I: assessment", Int. J. of Exergy, vol. 3(4), pp. 362-376.
- [10] Szargut, J., 2005, "Influence of Regenerative Feedwater Heaters on the Operational Costs of Steam Power Plants and HP Plants", Int. J. of Thermodynamics, Vol. 8(3), pp. 137-141.
- [11] Elfeituri A. L., "The Influence of Feed water Heaters Operation Conditions on the Exergy Loss and Economic Effects of a Steam Power Plant" PhD Thesis, Warsaw Technical University, Poland, (1997).
- [12] Cengel, Y. A., 1997, Introduction to Thermodynamics and Heat Transfer, McGraw-Hill, New York.