

# Electromagnetic Assessment of Submarine Power Cable Degradation Using Finite Element Method and Sensitivity Analysis

N. Boutra, N. Ravot, J. Benoit, O. Picon

**Abstract**—Submarine power cables used for offshore wind farms electric energy distribution and transmission are subject to numerous threats. Some of the risks are associated with transport, installation and operating in harsh marine environment. This paper describes the feasibility of an electromagnetic low frequency sensing technique for submarine power cable failure prediction. The impact of a structural damage shape and material variability on the induced electric field is evaluated. The analysis is performed by modeling the cable using the finite element method, we use sensitivity analysis in order to identify the main damage characteristics affecting electric field variation. Lastly, we discuss the results obtained.

**Keywords**—Electromagnetism, defect, finite element method, sensitivity analysis, submarine power cables.

## I. CONTEXT AND WORK OVERVIEW

**E**LECTRIC power supply is deeply involved in economic, strategic and environmental key issues nowadays. Offshore wind conversion represents one of the most important and the fastest growing resources for electric power generation. Submarine power cables are part of the electric collection and transmission grid which harvests the power produced by the wind farms and carry it to the shore. Maintenance of submarine power cables is proved difficult because of water depth, large length of the transmission link, besides rough climatic conditions. Faults on submarine power cables can occur during transport, installation and operating under high voltage power. The risks encountered can be related to natural ageing or unforeseen events such as ships anchoring. Submarine power cables are made of three coaxial cores, polymer insulated, copper or lead sheathed, steel armoured with some other layers insuring the proper cable functioning. They can be placed in a flat or trefoil formations.

In this paper, we investigate the fault initiators for short and long term cable failure prediction by means of an electromagnetic analysis. The finite element method (FEM) is used to solve the Maxwell's equations in low frequency, when the wavelength is greater than the cable dimensions.

N. Boutra is with the French Alternative Energies and atomic Energy Commission, Gif-Sur-Yvette, 91191 FR (phone: +33 1 69 08 93 90 fax: +33 1 69 08 83 95; e-mail: nadir.boutra@cea.fr).

N. Ravot is with the French Alternative Energies and atomic Energy Commission, Gif-Sur-Yvette, 91191 FR (phone: +33 1 69 08 37 87; fax: +33 1 69 08 83 95; e-mail: nicolas.ravot@cea.fr).

J. Benoit is with the French Alternative Energies and atomic Energy Commission, Gif-Sur-Yvette, 91191 FR (phone: +33 1 69 08 00 94; fax: +33 1 69 08 20 82; e-mail: Jaume.benoit@cea.fr).

O. Picon is with University of Paris-Est, Marne-La-Vall, ESYCOM (EA 2552) 77454 FR (phone: +33 1 60 95 72 84; fax: +33 1 60 95 72 14; e-mail: odile.picon@univ-mlv.fr).

Damage is represented as a crack characterized by its shape, and material. Then, the induced electric field distribution in terms of the damage characteristics is obtained. In order to determine the most contributing damage characteristics to the electric field's variation, we make use of sensitivity analysis. The electromagnetic problem is quasi static. If the electric field's variation only is taken into account, the capacitive phenomena can be studied, since displacement currents are dominant comparing to conduction currents. In this case, the problem is referred to as electro quasi static. On the other hand, if the magnetic field variation only is taken into account, the inductive phenomena can be studied and the problem is called magneto quasi static. Considering the magneto quasi static problem, the electric field induced in cable metallic layers can be obtained. An electric field is induced in the metallic layers because of the main current flowing into the cable center conductor. By scanning the metallic layer contour called screen, we have noticed that a crack in this layer increases the electric field's induced amplitude over the crack area. The application of the sensitivity analysis in our context aims at simplifying the electromagnetic analysis of the submarine power cable. The sensitivity analysis is a probabilistic approach that evaluates the impact of input data variability on the output of a model. Finally, we discuss the relevance of our electromagnetic analysis for detecting the considered damages and the possible use of this analysis as a sensing technique.

## II. SUBMARINE POWER CABLES FOR OFFSHORE APPLICATIONS

An offshore wind farm (OWF) is an electric facility that produces electric power from mechanical wind energy conversion. Submarine power cables are part of the electric collection and transmission grid which harvests the power produced by the offshore installation and carries it to the shore. An overview of the major components of an OWF are shown in Fig. 1.

As it can be seen in Fig. 2, we distinguish two groups of submarine power cables installed in an OWF facility. The inter-array cables (also called dynamic cables), which connect group of turbines to the offshore substation. The second group of cables are the export cables (called static cables) for transmitting the electric power from the offshore substation to the onshore collection point.

A cross section of a single core submarine power cable can be seen in Fig. 3. The conductor is made of copper or



Fig. 1 Offshore wind farm main components [1]

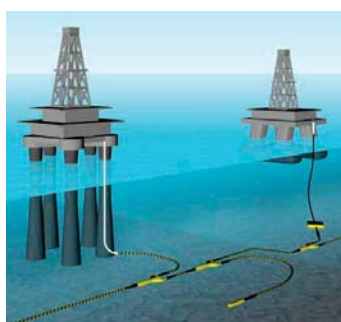

Fig. 2 Dynamic and static submarine power cables

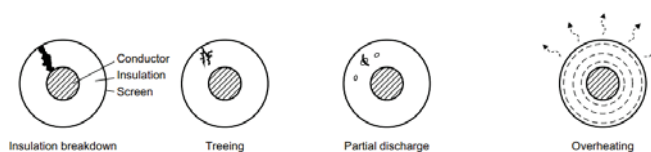

Fig. 5 Internal threats [5]

Open Science Index, Electronics and Communication Engineering Vol:11, No:3, 2017 publications.waset.org/10006567.pdf

aluminum stranded wires. the semi-conductive layers are made of polymer mixed with carbon black. a copper screen is used as an electric shield. Finally the outer sheath provides an overall protective covering [2].



Fig. 3 Single core submarine power cable cross section [3]

Submarine power cables failure has been surveyed by the CIGRE (Comité international des Grands Réseaux Electriques) [4]. The main cause of the submarine cable failure is reported to be originating from the cable environment such as: Fishing activity, anchoring (Fig. 4). Other causes of cable failure are attributed to the cable operational conditions such as: Overheating, high voltage combined with impurities and the weakening of the insulation system (Fig. 5)



Fig. 4 External threats

### III. ELECTROMAGNETIC QUASI-STATIC ASSUMPTION

Electromagnetic field phenomena are described by the set of Maxwell's equations. The quasi-static approximation means that the field considered are slowly varying with no spatial propagation. The contribution to electric and magnetic field from the  $\partial/\partial t$  terms in Faraday's and Ampere's law are sufficiently small that their own induced  $(\partial/\partial t)^2$  can be neglected. Only the original and first order induced fields are for interest [6]. This assumption holds if the the wavelength  $\lambda = c/(f * \sqrt{\epsilon_r \mu_r})$  is much larger than the length of the considered geometry.

### IV. CABLE MODELING AND FEM ANALYSIS

#### A. Finite Element Analysis

The FEM is a numerical method that enables solving differential equations, which governs physical phenomena. For some complex geometries and problems, no analytical solution can be computed. Instead, the geometry is cut into several pieces called elements and the equations are discretized to be solved within these small pieces. In electromagnetic simulations, FEM is used to calculate the electric and magnetic fields by solving the Maxwell's equations. In our work, a commercial electromagnetic solver (CST STUDIO SUITE) has been used to model the submarine cable and compute the electric and magnetic fields in low frequency (50 Hz).

#### B. Single Core Modeling

The metallic part of the cable are considered (center conductor and metallic screen) and the inductive phenomena are investigated. By adjusting both center conductor and metallic screen conductivity, these layers can be represented as cylindrical shapes. Since the problem need to be solved is a finite expansion, we have considered a small section of the cable, 100 mm length. A 600 A current excitation source is applied to the cable center conductor. The varying current generates a magnetic field, which in return will set an induced

current flowing into the screen. The current loop is mainly closed by the boundaries, equivalent to a perfect conductor. In order to evaluate the current induced in the metallic screen without the contribution of the current flowing through the bounding box, we have defined a termination on both sides of the model. This termination acts as a variable resistance (Fig. 6).

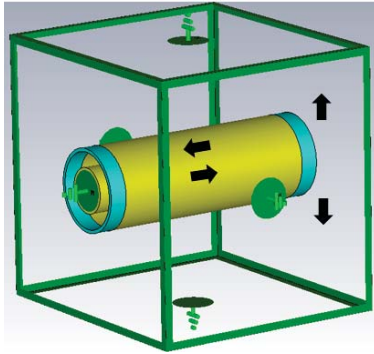

Fig. 6 The cable model and the boundary conditions

The amount of current flowing through the termination as a function of the termination resistance is represented in Fig. 7. If the termination resistance is low, it will allow some of the bounding box's current to flow through it and to be added to the induced current in the screen.

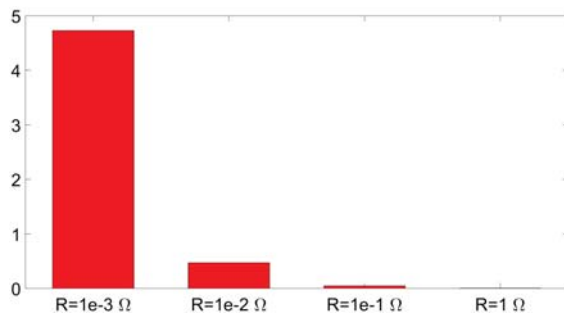

Fig. 7 Current flow across the termination resistance

For a termination resistance value of 1 ohm, the measured current into the screen is related exclusively to the inductive phenomena.

## V. SENSITIVITY ANALYSIS METHODS

Sensitivity analysis (SA) [7] is the study of how the variation of the output in a model (numerical or not) depending qualitatively or quantitatively upon the variability of the information fed into it (inputs). The sensitivity analysis approach is commonly used to identify important parameters that dominate model behavior. In this paper, the Morris screening method is used. The basic principle and the implementation of this method is explained, an application to the cable damage assessment is presented.

### A. Morris Screening Method

1) *Basic Principle:* The Morris method [8] is a one-at-a-time (OAT) approach, it is based on the elementary

effect. The elementary effect is calculated by changing individually by a small amount one input parameter. The Morris method comes with an experimental plan composed of the OAT randomized experiments. Each model input  $X_i$ ,  $i = 1, \dots, k$  varies across  $p$  selected levels. The elementary effect of the  $i$ th parameter  $x_i$  is defined as:

$$ee_j(x_i) = \frac{f(x_1, x_2, x_{i-1}, x_i + \Delta, x_{i+1}, \dots, x_k) - f(x)}{\Delta} \quad (1)$$

A convenient choice of  $p$  and  $\Delta$  is  $p$  even and  $\Delta = p/2(p - 1)$ . The process is described by the following mathematical equation:

$$B^* = (J_{k+1,1}x^* + \frac{\Delta}{2}[(2B - J_{k+1,k})D + J_{k+1,k}])P \quad (2)$$

The method proceeds as following:

- Randomly select a base value  $X^*$  for  $X$ , each component is sampled from the subset of possible values  $\{0, 1/(p - 1), \dots, 1 - \Delta\}$
- Increase one or more component of  $X^*$  by  $\Delta$  such that the resulting vector  $X^{(1)}$  is still in the set of possible values.
- Generate the second sampling point  $X^{(2)}$  from  $X^*$  with the property that it differs from  $X^1$  in the randomly selected  $i^{th}$  component by  $\pm\Delta$ .

The average of the elementary effects labeled  $\mu_i$  estimates the overall effect of each input on the output. A large mean of the elementary effect implies that the corresponding model parameter has an important influence on the model output. The average of the elementary effect is expressed as:

$$\mu_i = \frac{1}{r} \sum_{j=1}^r ee_j \quad (3)$$

The standard deviation of the elementary effects labeled  $\sigma_i$  estimates the higher order effects such as non-linearity and interaction between parameters. A high standard deviation indicates that either the parameter is correlated with other parameters or the parameter has non-linear effect on the output. The standard deviation of the elementary effects is expressed as:

$$\sigma_i = \sqrt{\frac{\sum_{j=1}^r (ee_j(x_i) - \mu_i)^2}{r}} \quad (4)$$

Both sensitivity measures are relative measures, their value does not have any specific meaning. It can only be used for comparing the influence between input parameters (example:  $\mu_1 > \mu_2$  then  $X^{(1)}$  is more influential than  $X^{(2)}$ ). The sensitivity measures can also be shown graphically by screening plots, which have the x- and y-axes the mean and the standard deviation respectively. Each input is represented in the screening plot by a point with coordinates  $(\mu_i, \sigma_i)$ . The plot can be divided into four quadrants exhibiting the influence of inputs on the output (see Fig. 8)

The main advantage of the Morris method is the low computational cost. One drawback is that it only gives an overall measure of the interactions.

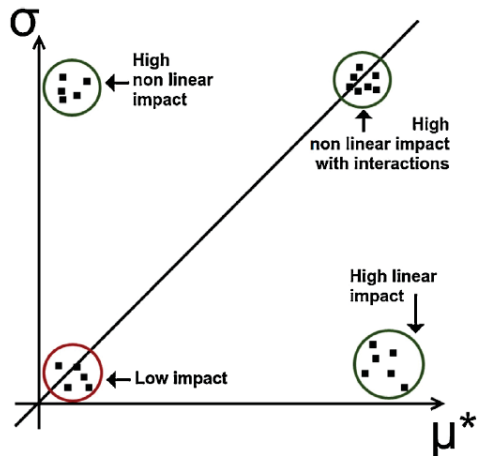

Fig. 8 Screening plot and impact of the input parameters

2) *Implementation and Benchmarking*: The Morris screening method has been implemented in MATLAB [9], [10]. The Morris method is after that tested on the analytical Sobol g-function defined as:

$$g(X_i) = \prod_{i=1}^k \frac{|4X_i - 2| + a_i}{1 + a_i} \quad (5)$$

where  $a_i$  are parameters, such that  $a_i \geq 0$ . The Sobol g-function is non-linear and non-monotonic. The values of the  $a_i$  determine the importance of the input  $X_i$ . The higher the  $a_i$ , the lower importance the importance of the input  $X_i$ . The behavior of the Sobol's g-function for one input  $X_1$  as a function of the parameter  $a_1$ , as:  $a_1 = 0.9$ ,  $a_1 = 9$  and  $a_1 = 99$ , is computed.

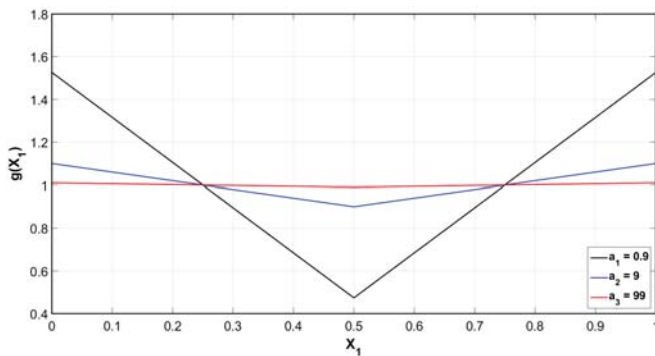

Fig. 9 Sobol g-function as function of one input  $X_1$  for  $a_1 = 0.9$ ,  $a_1 = 9$  and  $a_1 = 99$

It can be seen from Fig. 9 that the parameter  $a_i$  indicates the input importance into the variation of the Sobol g-function output. In order to apply the Morris screening method to compute the sensitivity of the Sobol g-function output, we assume  $k=6$  and we define the  $a_i$  parameter values as in Table I.

TABLE I  
 VALUES OF THE PARAMETERS OF THE G-FUNCTION FOR EACH INPUT

$a_1$	$a_2$	$a_3$	$a_4$	$a_5$	$a_6$
78	12	0.5	2	97	33

The Morris method is performed by assuming 6 input variables uniformly distributed in  $[0; 1]$ ,  $p = 4$ ,  $\Delta = 2/3$  are chosen and  $r = 4$  trajectories are employed.

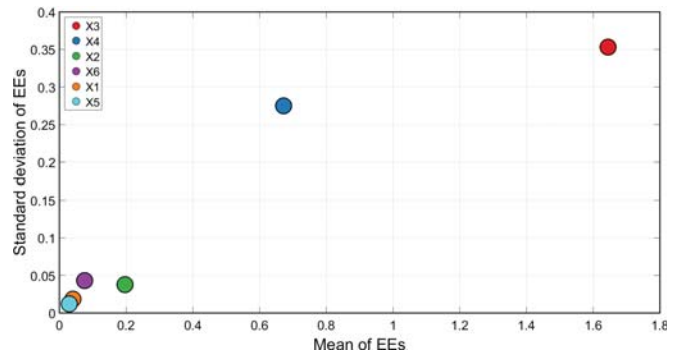

Fig. 10 Screening plot for the Sobol g-function

The screening plot for the Sobol g-function is represented in Fig. 10. As expected, the input variables  $X_3$  and  $X_4$  are the most relevant.

## VI. SUBMARINE CABLE DAMAGE DETECTION APPLICATION

### A. Screen Damage

In [11], we have shown that the amplitude of the induced electric field on the outer contour of the metallic screen increases in presence of a crack as defined in Fig. 11. The amplitude of the induced electric field norm on the outer contour of the screen as a function of crack's length and crack's opening angle are represented in Fig. 12. It can be seen at the center of the crack (located in the 90 angle position) that the amplitude of the induced electric field is bigger as the length and opening angle of the crack increase. In order to evaluate the behavior of the induced electric field in presence of a crack on the metallic screen, we have identified two more parameters responsible for the induced electric field variation. These parameters are the crack's depth and permittivity.

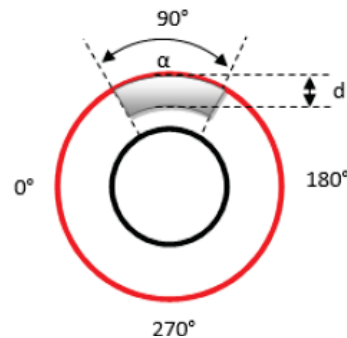

Fig. 11 Crack damage in the metallic screen

### B. Damage Parameters

Sensitivity analysis (SA) was performed on the four identified parameters responsible for the induced electric field variation on the outer contour of the metallic screen. The lower and upper limits of the input parameters are described in Table

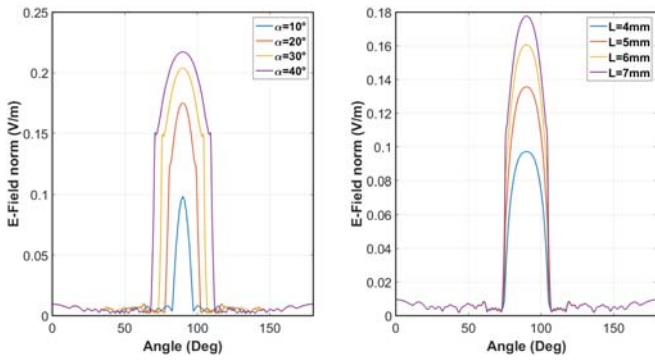

Fig. 12 Induced electric field variation on the outer contour of the metallic screen in presence of a damage

II. One output is studied: The pick amplitude of the induced electric field over the considered crack.

TABLE II  
 RANGE OF INPUT PARAMETERS CONSIDERED DURING SENSITIVITY ANALYSIS

Parameters	Maximum limit	Minimum limit
depth [mm]	2	0
Length [mm]	10	2
Angle [deg]	60	5
permittivity	80	1

### C. Morris Method Application

The Morris SA method has been applied for the fourth input parameters ( $M=4$ ). A number of 20 trajectories ( $r=4$ ) has been chosen. For consequence, we the model have been evaluated 100 times and the peak amplitude of the induced electric field on the outer contour of the screen as an output. The screening plot is shown in Fig. 13.

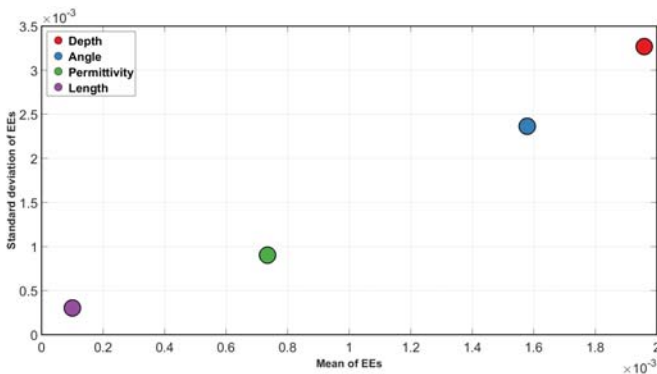

Fig. 13 Screening plot for the induced electric field on the outer contour of the metallic screen

The depth and the opening angle of the crack appear to be the most relevant parameters responsible for the induced electric field variation on the outer contour of the metallic screen. the crack's permittivity contributes, to a lesser extent to this variation. On the other hand, the screening plot reveals that the crack's length has a lower impact than the other input parameters.

## VII. CONCLUSION

The sensitivity analysis used in this work has been proved to be effective in identifying the few important factors contributing the most to detect a submarine single core power cable metallic screen damage, with a relatively small number of model evaluations. This study also found through the evaluation of the mean and standard deviation of the Morris elementary effects, computed for a crack's geometrical and material parameters, that the crack's depth and opening angle were dominant parameters as they had the mean and the standard deviation greater than other parameters.

## ACKNOWLEDGMENT

The authors would like to thank the French National Research Agency for the financial support and the EMODI project consortium members for the knowledge arising from their collaboration.

## REFERENCES

- [1] D. le trepot. (2017) How offshore wind farms work. [Online]. Available: <http://dieppe-le-treport.eoliennes-mer.fr/en/offshore-wind-power/how-offshore-wind-farms-work/>
- [2] T. Worzyk, *Submarine power cables: design, installation, repair, environmental aspects*. Springer Science & Business Media, 2009.
- [3] L. Henan Huatai Special Cable Group Co. (2017) Armored cable specifications. [Online]. Available: [https://huataitelan.en.alibaba.com/product/489593578-200736931/armoured\\_cable\\_specifications.html](https://huataitelan.en.alibaba.com/product/489593578-200736931/armoured_cable_specifications.html)
- [4] T. CIGRÉ, "Brochure# 379,," *Update of service experience of HV underground and submarine cable systems*, 2009.
- [5] *Subsea Power Cables in Shallow Water Renewable Energy Applications*, DNV, 2 2014.
- [6] D. H. Staelin, "Electromagnetics and applications," *Department of Electrical Engineering and Computer Science, Massachusetts Institute of Technology, Cambridge, MA, USA*, 2011.
- [7] A. Saltelli, S. Tarantola, F. Campolongo, and M. Ratto, *Sensitivity analysis in practice: a guide to assessing scientific models*. John Wiley & Sons, 2004.
- [8] F. Campolongo, J. Cariboni, and A. Saltelli, "An effective screening design for sensitivity analysis of large models," *Environmental modelling & software*, vol. 22, no. 10, pp. 1509–1518, 2007.
- [9] F. Pianosi, F. Sarrazin, and T. Wagener, "A matlab toolbox for global sensitivity analysis," *Environmental Modelling & Software*, vol. 70, pp. 80–85, 2015.
- [10] P.-A. Ekström, "Eikos: A simulation toolbox for sensitivity analysis," in *2nd International Conference on Radioactivity in the Environment, 26th October, 2005*, p. 361e364.
- [11] N. Boutra, J. B. N Ravot, and O. Picon, "Etude du champ electromagnetique dun cable sous marin dans le cadre d'un scenario de defaillance," in *13ème Colloque International sur la Compatibilité Electromagnétique, Rennes (France)*, 2016.