

# Application of Robotics to Assemble a Used Fuel Container in the Canadian Used Fuel Packing Plant

Dimitrie Marinceu

**Abstract**—The newest Canadian Used Fuel Container (UFC)- (called also “Mark II”) modifies the design approach for its Assembly Robotic Cell (ARC) in the Canadian Used (Nuclear) Fuel Packing Plant (UFPP). Some of the robotic design solutions are presented in this paper. The design indicates that robots and manipulators are expected to be used in the Canadian UFPP. As normally, the UFPP design will incorporate redundancy of all equipment to allow expedient recovery from any postulated upset conditions. Overall, this paper suggests that robot usage will have a significant positive impact on nuclear safety, quality, productivity, and reliability.

**Keywords**—Used fuel packing plant, robotic assembly cell, used fuel container, deep geological repository.

## I. INTRODUCTION

THE Nuclear Waste Management Organization (NWMO) is implementing Adaptive Phased Management (APM), the approach selected by the Government of Canada for the long-term management of Canada’s used nuclear fuel [1]. The goal of APM is the development of a Deep Geological Repository (DGR), constructed in a suitable rock formation in either sedimentary or crystalline rock. The repository design concept is based on a multiple-barrier system that incorporates engineered and natural barriers to contain and isolate used nuclear fuel (Fig. 1). The implementation of APM is based on safety, technical excellence, and social acceptability. An objective of the APM Engineering Program is to develop preliminary designs and cost estimates for the DGR. This includes the design of robotic equipment to transfer and package used nuclear fuel at the UFPP surface facility at the DGR site.

As of June 2010, approximately 2.2 million used Canadian Deuterium Uranium (CANDU) fuel bundles were in storage at Canadian reactor sites. Used nuclear fuel is currently stored in wet bays or in dry storages located at the reactor sites. Used nuclear fuel will be delivered in suitable transportation casks to the DGR site, where it will be repacked into corrosion-resistant, long-lived containers, and then transferred underground to be placed in the repository [5].

The UFPP, which will be part of the DGR surface facilities (Fig. 1) [2], is designed to receive used nuclear fuel in the transportation casks and transfer it to the long-lived UFCs. The UFC is sealed, inspected, and placed into a shielded transfer cask for transport to the underground repository. The UFPP is designed to process 120,000 CANDU used fuel

bundles per year over its 40-year lifetime. This is high throughput for a nuclear facility.

Nuclear fuel removed from a reactor core is highly radioactive and must be handled in environments that provide both shielding and containment. As such, areas designed for the handling of used fuel are normally not accessible to operators, and remote-controlled equipment is required for fuel-handling operations.

In the case of the UFPP, the fuel received at the plant will be packed under dry conditions into UFCs. Fuel handling operations including loading and sealing of the UFCs will be performed within a containment volume, which provides shielding for the safety of UFPP personnel.

Another requirement for the UFPP systems design is redundancy. Operators must be able to recover from upset conditions and continue the fuel packing operations using redundant equipment. Remote handling processes and equipment are required for this purpose. Historically, remote manipulators have been used in such environments. Recent advances in robot technologies for harsh environments make robot usage in nuclear facilities a viable option. Provisions for recovery from upset conditions place unique design constraints on the integration of robots in the plant processes.

In the present context, a robot is a programmable machine that can be easily reprogrammed when required. It consists of mechanical components, actuators, controls and sensors, and generally has three or more degrees of freedom.

A manipulator has similar features to those of a robot, but it is normally under the direct control of an operator, usually in the form of manual remote control.

## II. OPERATIONS TO BE DONE WITH ROBOTS IN THE UFC ASSEMBLY CELL

The applicability of robotic equipment to carry out the operations in the UFPP was evaluated in our previous published paper [3].

For the Mark II UFC, in its Assembly Cell (one of the UFPP’s most important cells), the following main operations are executed:

1. Transfer of the UFC from transport dollies, into the operational assembly area;
2. Local pre-heating prior welding;
3. HLW-seal welding of the lid onto UFC;
4. Weld grinding (if needed);
5. Inspecting the closure seal;
6. Repairing any detected weld defects;
7. Installing a corrosion barrier (“cold” copper spray) over the welded areas;

Dimitrie Marinceu is with the Nuclear Waste Management Organization, Canada (e-mail: dmarinceu@nwmco.ca).

- 8. Copper layer annealing;
- 9. Sprayed copper shell-clean machining (if needed);
- 10. Inspecting the UFC;
- 11. Placing the UFC back into the transport dollies.

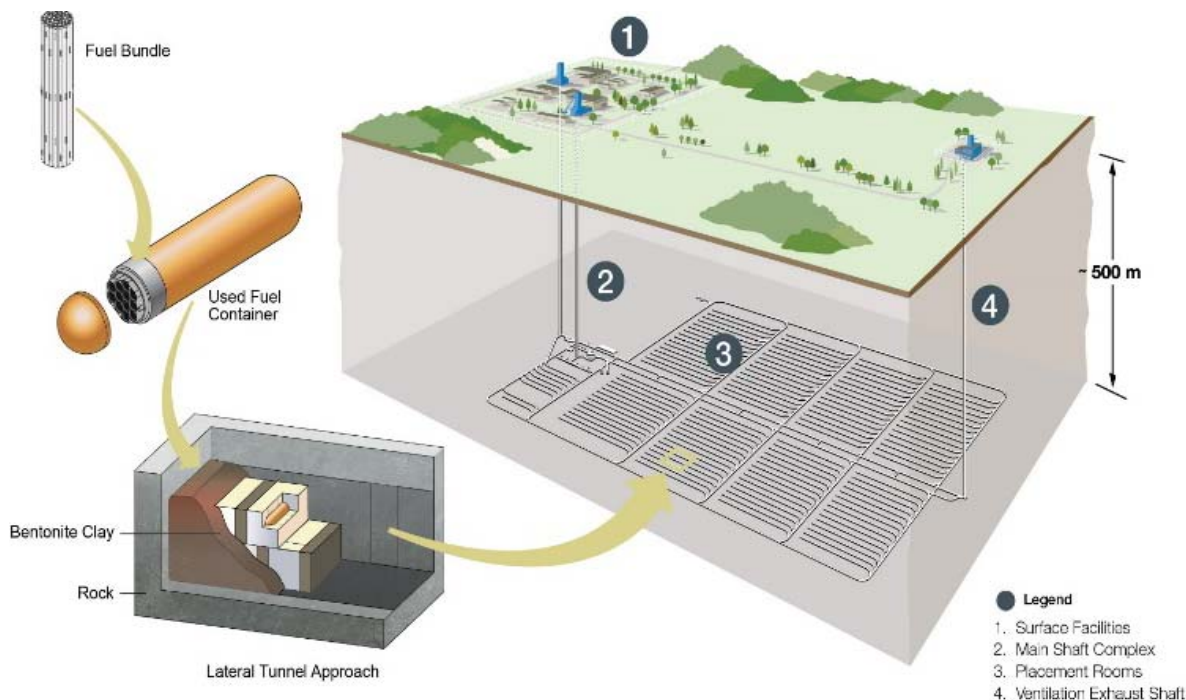

Fig. 1 APM deep geological repository

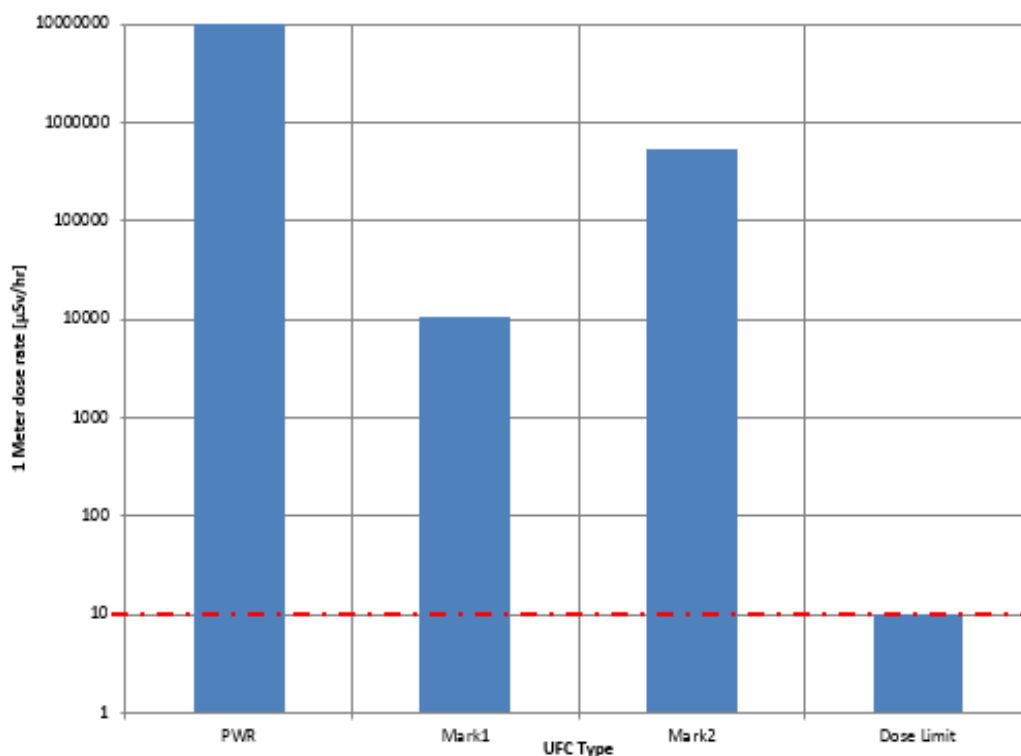

Fig. 2 Radiation dose rates (radial, gamma -1m)

From the above, using principles shown in [x], we calculated that robots can be used extensively for the operations no: 3, 4, 5, 6, 9, and 10. Future developments for

the Cu “cold” spray technologies will permit, maybe, robot usage also for operation 7.

### III. RADIATION LEVELS IN THE UFPP UFC ASSEMBLY CELL AND CONSEQUENCES

In [3], some aspects related to radiation level influence on the robotic equipment used in the UFPP were mentioned.

Because the Mark II UFC has thinner walls than its predecessors, the radiation level in the cell can be relatively high (max. gamma of 543 mSv/hr at 1 m from the UFC surface –in UFC radial direction [4]). See Fig. 2 for details.

Special radiation protection measures are suggested to be taken in the cell. We mention some [3]:

- Replacing or elimination of plastic or rubber materials in the cell's construction;
- Radiation-hardened electrical motors and encoders;
- Minimum IP67 qualification for all actuators;
- Motor and encoder redundancy;
- Manipulator motor override possibility;
- Manipulator-friendly fasteners and surfaces for the robot's components, for recovery and maintenance;
- Simple assembly, disassembly and maintenance procedures that can be accomplished by remote manipulators;
- Main components and subassemblies sized to fit into UFPP low-level waste container for easy disposal;
- Accessible lift points for crane lifting;
- Radiation-resistant cables and hoses;
- Washable components for ease of decontamination.

Due to the radiological hazard, human presence in the cell would be very limited, and manipulators will be used for maintenance, repairs, recovery from upset conditions within the LWC.

### IV. UFC ASSEMBLY ROBOTIC CELL DESCRIPTION

Figs. 3-5 show the presented ARC layout.

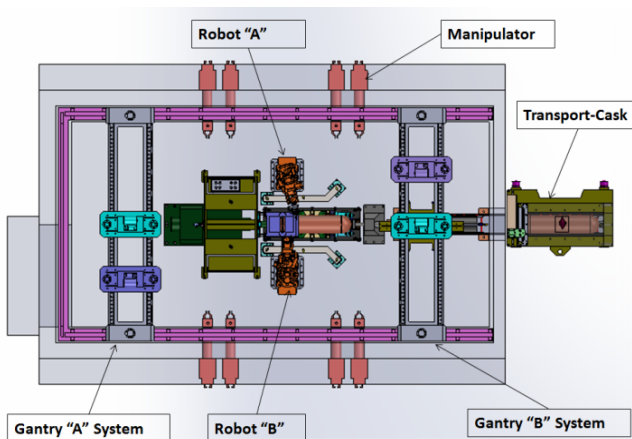

Fig. 3 ARC-Top View

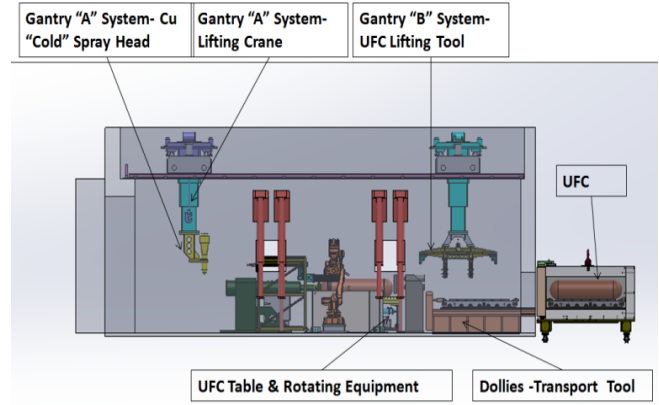

Fig. 4 ARC-Side View

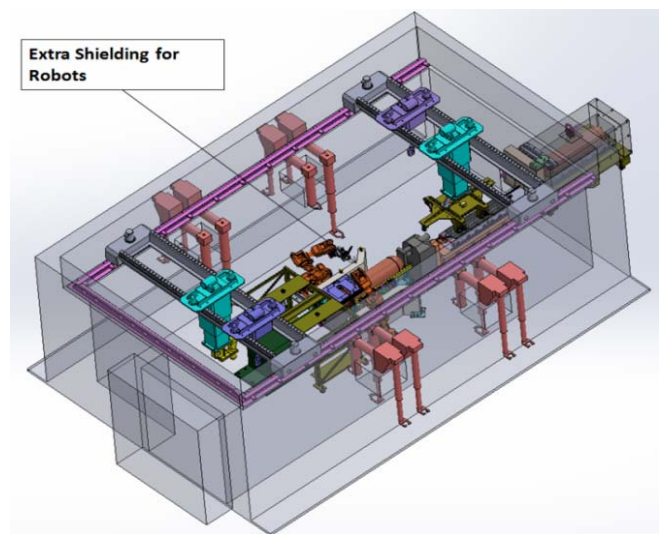

Fig. 5 ARC-ISO View

The main components of the ARC are:

- Dual Gantry systems (called "A" and "B");
- Two stationary radiation hardened (commercially available) RRRRR robots ("A" and "B");
- UFC lifting equipment (on Gantry "B");
- Cu "cold" spray system (on Gantry "A");
- Manipulator systems for disturbance handling;
- UFC lifting and rotating table;
- UFC steel vessel heating (prior, after or during welding), Cu annealing (after Cu spray), chips and dust (or sparks) evacuation, and "all-time" UFC surfaces protection system;
- IR cameras for temperature control;
- Extra radiation shielding for the robots;
- The transport cask docking station;
- Dollies transfer tool.

The Gantry "A" is dedicated for Cu cold spray operation and various lifting needs. The Gantry "B" is dedicated for UFC lifting and various other needs.

The robot "A" is dedicated for Hybrid Laser Welding only. It has welding head interchangeability assured (not shown for clarity). The robot "B" is dedicated for: NDE, milling,

grinding, etc. It has various tooling interchangeability assured (not shown-for clarity).

#### V. DETAILS OF ROBOT USAGE IN THE CELL

The robots “A” and “B” have some well-defined “non-active” configuration positions, behind the extra radiation shielding (incoming radiation is minimized). This fact will ensure a relative long “life” for the equipment. Fig. 6 shows the radiation shields.

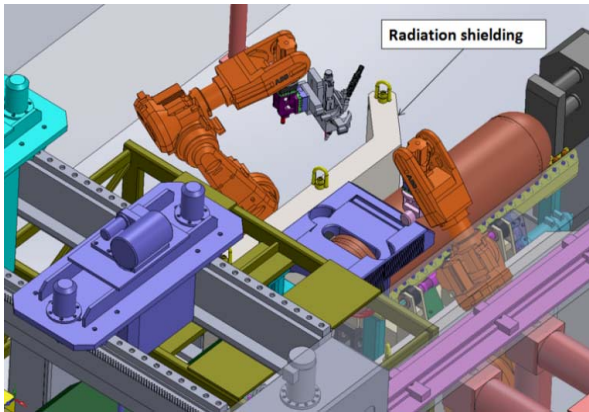

Fig. 6 Robot - Radiation Shielding

The UFC closure weld is a key step in the fuel packing process. The weld integrity ensures containment and isolation of the used fuel.

Using a robot is the appropriate choice for performing this essential task. Robot “A” is dedicated for this task-only. Robot “A” has one inter-changeable (redundancy) Hybrid Laser Welding (HLW) head, with which the robot is performing the welding. See Fig. 7. The interchangeable tooling storages are not shown for clarity purposes.

One interesting feature of the ARC is the UFC protection, heating, dust and gases evacuation tool. The heating can be done during HLW operation if needed, which will improve the quality and the productivity of the entire operation. Fig. 10 shows the heating and protection head.

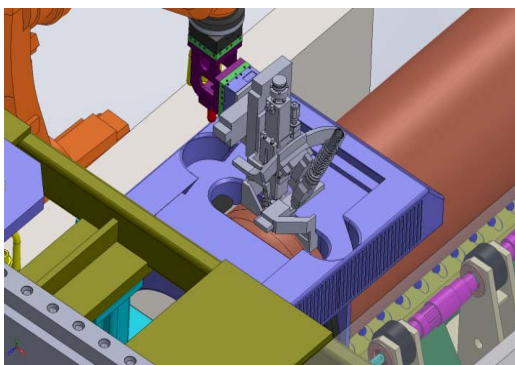

Fig. 7 UFC- Hybrid Laser Welding using robot “A”

The robot “B” has multiple tasks. Some of these tasks, are shown in Figs. 8 and 9.

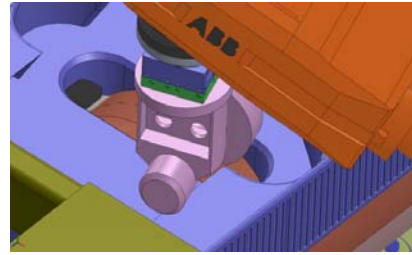

Fig. 8 UFC Grinding (or Milling)- using Robot “B”



Fig. 9 UFC NDE- using Robot “B”

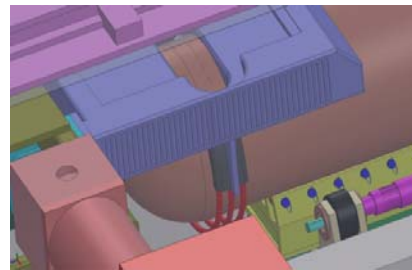

Fig. 10 UFC Heating, & Protection Tool

#### VI. CONCLUSIONS

In the Mark II UFC Assembly Cell- considering adequate shielding strategies, safe robotic work processes can be implemented. Reducing robot radiation levels has a positive impact on both safety and system design, which translates to a positive economic impact. The robots will have special features [3].

Like in the entire UFPP, in ARC-remote manipulators are intended to be used, in order to provide the required redundancy for recovery from process upsets.

Robot usage will provide a significant positive impact on nuclear safety, quality, productivity, and reliability.

#### REFERENCES

- [1] Nuclear Waste Management Organization. 2005. Choosing A Way Forward: The Future Management of Canada’s Used Nuclear Fuel – Final Study. Issued by NWMO to the Minister of Natural Resources Canada in November 2005, Toronto, Canada.
- [2] SNC Lavalin “Deep Geological Repository Design Report, Crystalline Rock Environment”, 0206-06-6100-REPT-0001, Toronto, Canada.
- [3] D. Marinceu, A. Murchison, C. Hatton – “Robots Usage into a Canadian Used Nuclear Fuel Plant”, CARPI 2012, Zurich.
- [4] C. Medri, Internal document: “Scoping Estimates of UFC Shielding Thickness Requirements”, APM-CALC-04330, NWMO, April 2012.
- [5] Z. G. Keszthelyi, D. Morikawa - “The CANDU 9 Fuel Transfer System”, First Conference on CANDU Fuel Handling Systems”, May 1996, Toronto.