

Seismic Soil-Pile Interaction Considering Nonlinear Soil Column Behavior in Saturated and Dry Soil Conditions

Mohammad Moeini, Mehrdad Ghyabi, Kiarash Mohtasham Dolatshahi

Abstract—This paper investigates seismic soil-pile interaction using the Beam on Nonlinear Winkler Foundation (BNWF) approach. Three soil types are considered to cover all the possible responses, as well as nonlinear site response analysis using finite element method in OpenSees platform. Excitations at each elevation that are output of the site response analysis are used as the input excitation to the soil pile system implementing multi-support excitation method. Spectral intensities of acceleration show that the extent of the response in sand is more severe than that of clay, in addition, increasing the PGA of ground strong motion will affect the sandy soil more, in comparison with clayey medium, which is an indicator of the sensitivity of soil-pile systems in sandy soil.

Keywords—Beam on nonlinear Winkler foundation method, multi-support excitation, nonlinear site response analysis, seismic soil-pile interaction.

I. INTRODUCTION

SOIL-PILE-STRUCTURE interaction plays a paramount role in seismic evaluation of structures founded on piles. Considering the effect of soil-pile interaction, structure response can be greatly different from that of a fully restrained structure. Currently, many building and bridge design codes use factored static loads to explain dynamic effects of piles in the structure. Although, in very low amplitude vibrations, this approach is capable of modeling the system with reasonable accuracy, the effects of nonlinear soil behavior, damping and dynamic soil-pile interaction can render the structural response notably different. Nevertheless, considering the lack of a comprehensive research in seismic soil-pile-structure interaction (SSPI) to account for different conditions of saturated and dry soil, there is still room for improvement of SSPI analysis. The aim of this research is to evaluate the valid methods of SSPI in saturated and dry soil conditions.

Currently, in order to analyze the pile-soil systems, most of the researchers use three methods namely: numerical study using Finite Element Method [1], [2], Boundary Element Method [3], and Winkler Springs (p-y springs) Method [4]. These solutions reasonably consider the bilateral effects of foundation and ground surface excitement, inertial and kinematic interactions between pile and soil, and therefore, they are used in practical projects and researches depending on

the type of application. This research focuses on Winkler springs (Dynamic p-y).

Dynamic p-y method has long been implemented for solving problems related to seismic soil-pile interaction (see [5]-[12]). Wang et al. [13] evaluated different methods to apply dynamic p-y and concluded that calculations can be sensitive to the detailing of nonlinear springs and dampers, however different methods lead to identical results when using similar spring-damper configurations.

Penzien et al. [14] were among the first researchers who developed a method for seismic analysis of piles. They introduced a system based on separate parameters and multi degrees of freedom elements to model the response of soil media under seismic excitation. In this method, to account for the nonlinear hysteretic response of soil, bilinear springs along with parallel and series dampers are respectively implemented to account for soil damping and creep. After Penzien et al. [14]; [10]-[12], [15], [16] attempted to provide models for seismic response analysis of the pile.

Accuracy and precision of the p-y dynamic method have been evaluated by several studies, most of which were in the form of laboratory tests using the centrifuge method [4], [17]-[19]. Boulanger et al. [4] used a particular type of dynamic p-y element for soft clay; and the results were validated against centrifuge tests. Curras et al. [17] used another type of dynamic p-y to evaluate the response of structures based on a group of piles and take advantage of one-dimensional analysis and equivalent linear method for site response analysis. The method of this research is similar to the method of Boulanger et al. [4] for seismic soil-pile interaction.

In this research, to evaluate site response, a 2D finite element model has been developed considering the nonlinear behavior of soil material. Soil parameters have been selected using recommendations in OpenSees software. The output of soil column excitation at different depths are used as input excitations of the pile-soil model to evaluate the pile-soil interaction, and the results are presented in the form of a spectral acceleration response recorded at the top of the pile in different soil types, and saturated and dry conditions.

II. NONLINEAR SOIL COLUMN MODELING

During an earthquake event, there is a significant difference between the excitation recorded at the ground surface and the excitation recorded in the bedrock or outcrop rock, and this difference will vary depending on the depth of the data recording set and the soil type of the site. This difference is

especially important in modeling of soil-structure systems. Currently, numerous softwares such as SHAKE and EERA [20], [21] have been developed to analyze the response of semi-infinite soil medium and are mostly based on the equivalent linear model concept. Based on this concept, the nonlinear cyclic behavior of soil in high strains can be simulated by an equivalent linear system. The equivalent linear model is in fact a simplification of the viscoelastic model known as the Kelvin-Voigt model [23].

Although the equivalent linear approach has an acceptable performance in many cases and shows quick performance and adequate accuracy in intense vibrations, the method generates responses far from reality, especially when an incremental dynamic analysis (IDA) is in progress [26]. Thus, in the present study, accurate simulation of site response considering the nonlinear behavior of the soil was placed in the agenda. The soil column analysis has been performed taking advantage of the finite element method in the OpenSees platform in dry and saturated soil conditions. The dry and saturated conditions have been modeled using total stress and effective stress methods, respectively, and the model is verified against centrifuge results. At each elevation, the output of site response analysis is used as the input excitation to the free ends of p-y, t-z and Q-z springs at different depths as the input excitation using multi-support excitation method.

In soil column analysis, complex algorithms are used to ensure the stability and convergence of solution, most of which are rooted in numerical theories to solve dynamic problems. One of the most powerful available methods is the method presented by Courant, Frederick and Levy [24] to ensure the validity of the time step to solve the problem. Based on this method, the user makes sure that the time step is small enough to make the analysis stable. Accordingly, having maximum shear wave velocity in soil medium and the size of the vertical element, the time step and total number of steps necessary to solve the problem are calculated and the dynamic analysis is performed based on these results.

In dry site response analysis, since groundwater is absent in the soil medium, the total stress method is implemented for the analysis. In the finite element model, soil elements have been modeled using 4-node quad elements with two degrees of freedom, and plain-strain formulation. The general form of the model is shown in Fig. 1.

In this section, horizontal and vertical degrees of freedom are respectively the first and the second degrees and numbering of nodes and elements start from the bottom of the soil column. To consider the finite rigidity of the bedrock underneath the soil column, Lysmer-Kuhlemeyer dashpot [27] at the bottom of soil column has been modeled using zero-length element and viscous materials. According to Joyner and Chen [28], the damper coefficient is calculated by multiplying the shear wave velocity of the underlying bedrock by the density of bedrock. Earthquake excitation is applied to the bottom of soil column and on the bedrock in the form of a force time-history resulting from bedrock damper resistance. Mesh size must meet the conditions of the problem according to the theory of wave propagation. According to Kramer's

recommendations [26], a total of eight to 10 elements should be placed in a wavelength to ensure the accuracy of numerical modeling results. The cut-off frequency (maximum frequency) and the number of elements available in a wavelength should be selected to meet this condition accordingly. The wavelength of the seismic wave in this case is calculated by dividing the minimum shear wave velocity by the determined cut-off frequency and the size of the vertical elements are then calculated based on the resulting wavelength. Dimensions of horizontal elements are also set to be equal to the smallest dimension of the vertical elements. Ultimately, soil nodes are automatically created based on meshing dimensions. The final node which has been defined for Lysmer dashpot definition is in the same location with node number one, and this point is fixed in all degrees of freedom defined in the problem domain, however it is connected to the first node by a *zero-length* element defined by viscous materials.

The bottom nodes of the soil column are fixed against vertical displacement because the bedrock prevents their vertical movement. In the rest of points, all nodes with equal elevations are horizontally tied to each other to have identical displacements.

When allocating proper material properties to soil elements, extreme attention should be paid to the properties of external load exerted on soil medium, the mechanical behavior of soil during the formation of stress field, and the behavior of the soil during the application of the shear force. Soil constitutive models in OpenSees are based on the multi-yield surface plasticity framework [29]. For fine grained and coarse grained materials, *PressureDependMultiYield* and *PressureIndpenedMultiYield* are used, respectively.

In the grained materials, the modulus of elasticity and lateral earth pressure depend on a confining pressure exerted by finite soil elements. Thus, a grained soil will show different mechanical properties at different depths and its yield surface in the main stresses space depends on the confining pressure (σ'_3), as shown in Fig. 2. Thus, *PressureDependMultiYield* material have been used to model sandy soil in this project.

In fine-grained materials, stress-strain behavior of soil is insensitive to confining pressure exerted on the soil elements [31] (Fig. 3), thus, its yield surface can be modeled in form of a multi-surface Von-Mises independent of the main stress of σ'_3 . In this study, *PressureIndpenedMultiYield01* material has been used to model fine-grained soil.

The first step of the analysis is gravitational analysis to create stress field at different depths and to form soil elements' confinement pressure. This step is divided into elastic and plastic parts. In the first part of the analysis transient analysis with a large time step is carried out where the behavior of soil materials is elastic; then, soil domain is prepared for plastic analysis by updating the parameters of defined materials. In this step, there is no external load and weight of soil elements acts as the.

After the gravitational analysis step, according to the proposed method by Joyner and Chen [28], the force history is applied to the bottom of the soil column. Since the elastoplastic model is used, there is inherent hysteresis damping in the model, however, a small amount of Rayleigh

damping is defined in the model to ensure the existence of damping in very low strains.

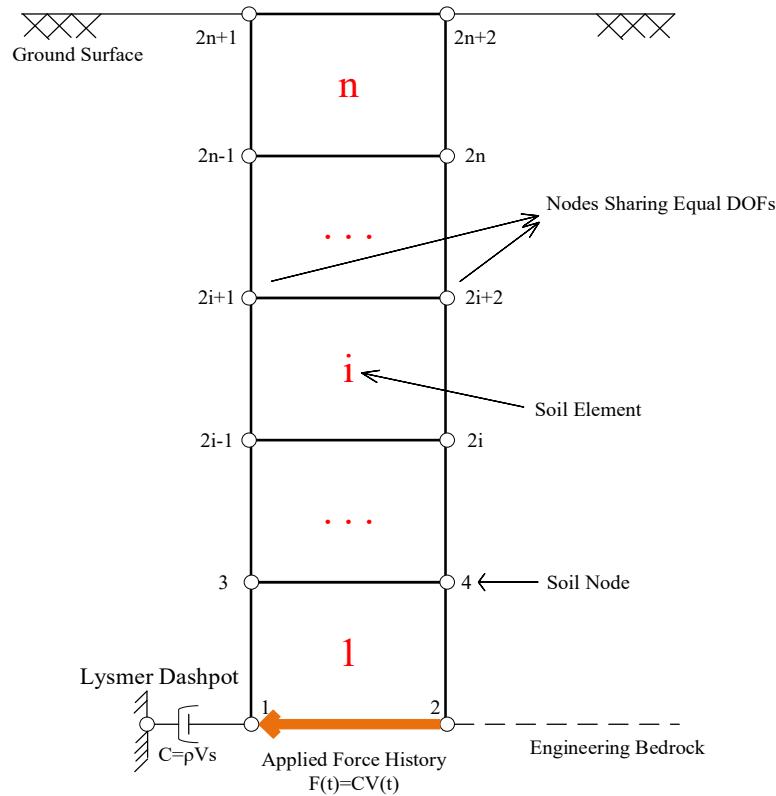

Fig. 1 Soil-column modeling in dry condition

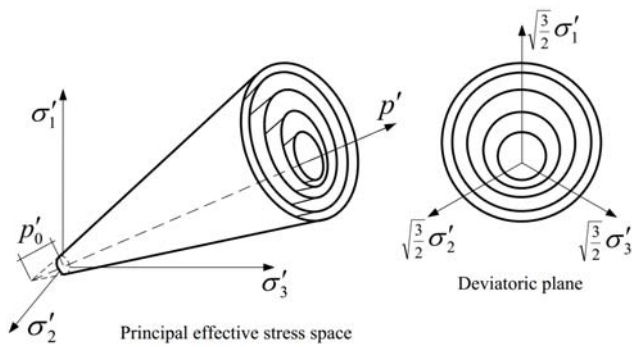

Fig. 2 Yield surface and behavior of pressure-dependent materials [30]

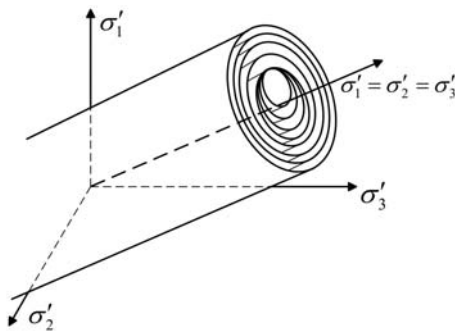

Fig. 3 Yield surface of materials independent of the pressure (for fine-grained soil) [30]

III. VERIFICATION OF SOIL COLUMN MODEL

Finite element model has been verified against centrifuge test results conducted by Hashash et al. [32]. In the centrifuge experiment, a layer of Nevada sand with prototype depth of 26 meters and a relative density of 60% was exposed to a different one-dimensional earthquake. After necessary instrumentation, the set of box and soil was subjected to six acceleration time histories which were recorded on the bedrock. The results have been provided in the form of spectral acceleration and Arias intensity at different depths.

TABLE I
 CHARACTERISTICS OF THE EARTHQUAKE USED IN CENTRIFUGE TEST AND VALIDATION MODEL

Event Name	Year	Moment magnitude	Site	Record Identifier	Distance to rupture (km)	PGA (g)
Kobe	1999	6.9	Takatori	TAK090	1.5	0.76

To validate the finite element model, an earthquake event according to Table I was used as the input excitation to the soil column and the spectral acceleration was compared to the spectral acceleration derived from centrifuge test. The result of the comparison is depicted in Fig. 4. According to Fig. 4, the results of the numerical model have reasonable correspondence with the centrifuge test results. The greatest difference can be observed in the periods under one second, which can be due to the low amount of damping defined in the

numerical model. Also, given that the data recording in numerical model is done with more accuracy compared to the data recorded by the accelerometers, data of numerical model show more fluctuations.

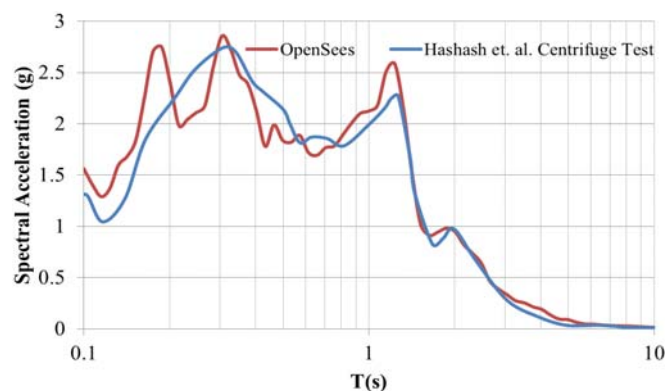

Fig. 4 Validation of soil column analysis code using the results of centrifuge test, comparison of spectral acceleration (5% damping) obtained from tests and OpenSees model

A method similar to dry condition is implemented to model soil column in saturated condition, with the only difference that, instead of 4-node elements, 9-node elements (according to Fig. 5) have been used and there are pore water pressure degrees of freedom of in corner nodes in addition to translational degrees of freedom, other nodes in this type of element have only two horizontal and vertical degrees of freedom.

9 node Quad_U_P Element

- Corner Nodes: 3 DOFs (U1, U2, Pore Pressure)
- Middle Nodes: 2 DOFs (U1, U2)

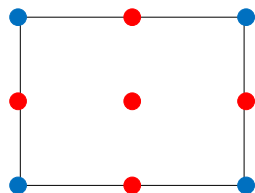

Fig. 5 9-node element with degree of freedom of pore water pressure in corner nodes

In the finite element model for site response analysis, user is able to define the ground water level, and accordingly, in the elements placed above the groundwater level, the pore water pressure degree of freedom will be fixed, hence, the stresses in these elements are calculated based on total stresses, and the stresses in elements under the groundwater level will be based on the effective stress method.

Similar to the dry condition, A gravitational analysis must be done in the first step, however, in the saturated condition, and 9-node elements, body forces are defined by applying gravitational acceleration.

Permeability of the soil elements is initially set equal to one m/s in order to ensure formation of the hydrostatic conditions after applying gravity loads. After gravitational analysis, and when all geostatic and hydrostatic stresses are created in the model, permeability parameter is updated properly to account for pore water generation during seismic excitation.

Aside from conditions and modeling techniques discussed in the preceding paragraphs, in saturated condition, other definitions are totally identical to that of dry condition.

IV. SEISMIC SOIL-PILE INTERACTION

In this section, initially, the pile model is developed using the method introduced by Boulanger et al. [4]. The, output excitations at every elevation is extracted from the soil column analysis and these excitations are applied to the free ends of the springs as the input excitation using multi-support excitation pattern. Analyses have been divided into two categories of dry and saturated in order to consider the effects of dry and saturated soil condition.

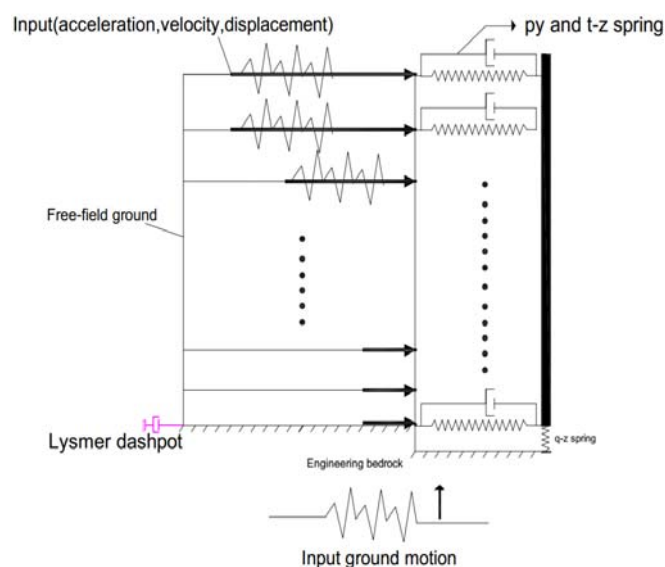

Fig. 6 Method of seismic analysis of pile-soil interaction considering the effect of site response

For seismic analysis of soil-pile interaction, one record out of the 44 records suggested by [33] FEMA p695 for the purpose of collapse analysis, is used according to the specifications presented in Table II. These records were initially divided into the relevant PGA then were scaled to $PGA = 1$. Afterwards, in each seismic analysis they were multiplied by a certain scale factor according to the desired PGA level.

TABLE II
CHARACTERISTICS OF THE EARTHQUAKE USED IN CENTRIFUGE TEST AND VALIDATION MODEL

Event Name	Year	Moment Magnitude	Site Name	Reference
San Fernando	1971	6.6	LA-Hollywood	PEER

TABLE III
CODING THE CONDUCTED SEISMIC ANALYSES

Specification	Explanation of the relevant index
S	Soft clay: 1
	stiff clay: 2
	Sand: 3
P	PGA in terms of g

Table III summarizes the specifications used to represent seismic analyses results. For example, according to Table III, data shown as S1P0.25 represents the seismic analysis on the soft clay with PGA = 0.25.

V. RESULTS AND DISCUSSION

As shown in Fig. 7, spectral acceleration recorded at the top of the pile shows that the response received is greater in sandy soil compared to soft and stiff clayey soils. In addition, the increased level of PGA makes the difference of responses among different soils more clear. The results also show that making PGA four times greater makes the behavior of various soils different, the highest increase in response occurs in soft clay which experiences the greatest response intensification after sand and stiff clay. This is due to the fact that, in sand, dynamic compaction with increased earthquake intensity makes the soil denser, and in stiff clay, less deformation occurs compared to soft clay; and as expected, the responses and their intensifications are lower with increased earthquake intensity.

Hysteresis damping during dynamic loading in soils is dependent on cohesiveness and also the maximum shear modulus of the soil. Accordingly, the Hysteresis damping in the soft clay is more than stiff clay, and this level is more in stiff clay compared to sand. Thus, the response amplitude is smaller in soft clay.

Open Science Index, Geotechnical and Geological Engineering Vol:11, No:2, 2017 publications.waset.org/10006530.pdf

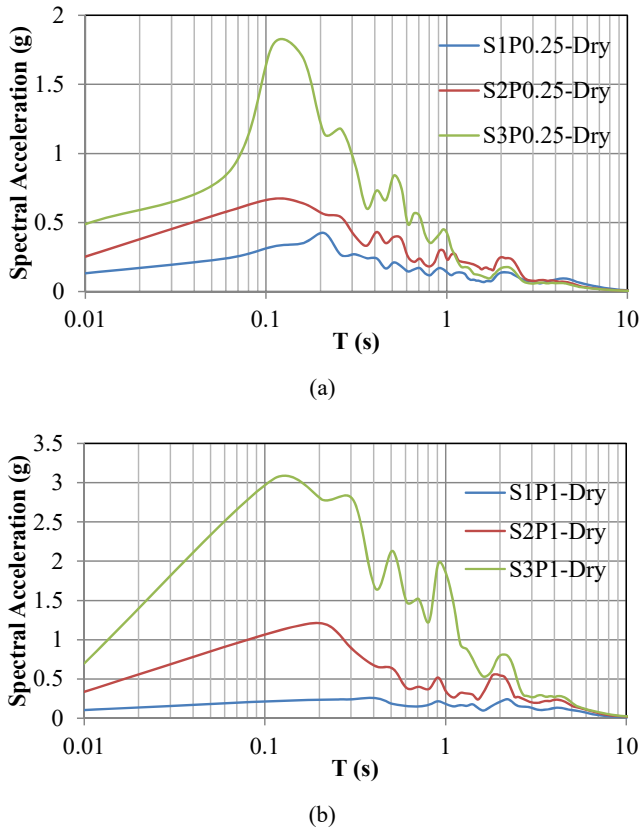

Fig. 7 The results of spectral acceleration (5% damping) obtained from accelerogram recorded at the pile top in different soils in dry conditions: (a) for PGA = 0.25, (b) for PGA = 1.

In case of saturated soil, as it is shown in Fig. 8, the same procedure as dry soil can be observed. Another important point about spectral response values is the value of inherent Hysteresis Damping in each type of soil. According to the studies of Vucetic and Dobry [22] and Seed et. al. [25], the

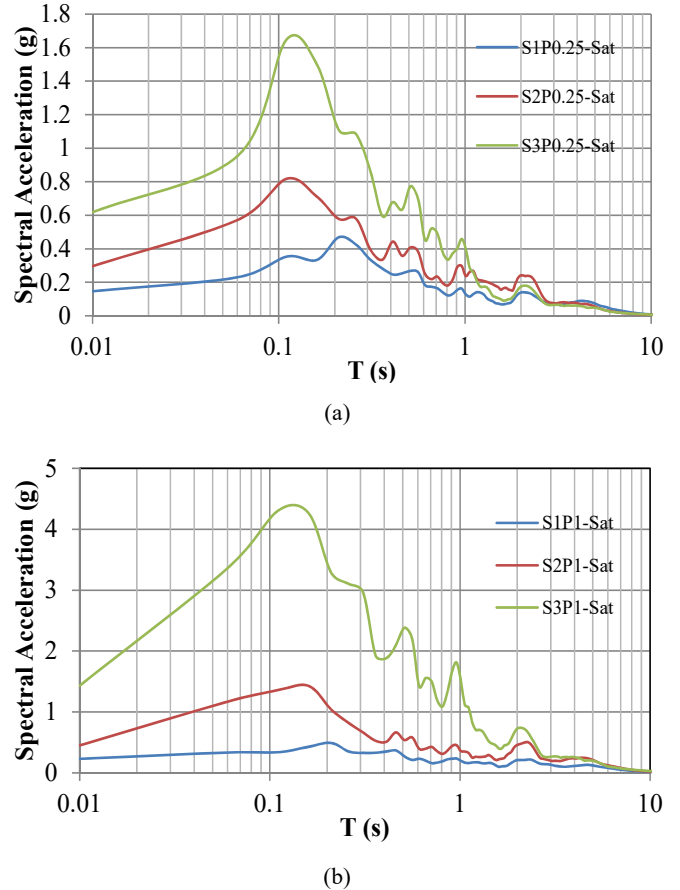

Fig. 8 Spectral acceleration (5% damping) calculated from acceleration time history recorded at the pile top in different soil types saturated conditions: (a) PGA = 0.25, (b) PGA = 1.

TABLE IV
 CHARACTERISTICS OF THE EARTHQUAKE USED IN CENTRIFUGE TEST AND VALIDATION MODEL

Parameter	Dry condition, PGA = 0.25	Saturated condition, PGA = 0.25	Change in soil condition (%)	Change in saturated soil condition (%)
PGA (g)	Soft clay	0.1	0.18	Soft clay 50
	stiff clay	0.2	0.35	stiff clay 48
	Sand	0.48	0.65	Sand 56
Maximum spectral acceleration (g)	Soft clay	0.31	0.48	Soft clay 65
	stiff clay	0.72	0.81	stiff clay 74
	Sand	1.6	1.68	Sand 94

To determine the effect of increasing PGA on the response of the soil-pile system in each of the dry and saturated conditions, a comparison has been carried out according to

Table IV. Evaluated parameters are maximum spectral response and PGA recorded at the soil surface.

Accordingly, sand showed the greatest change in all parameters due to increased PGA. Also, neglecting changes in the sand, fine grained saturated soil experiences less effect

from this increasing the PGA level, in average, and the effect of increased PGA on dry soil is greater.

To evaluate the effect of dry or saturated soil, the results of each of these two conditions were compared in Fig. 9.

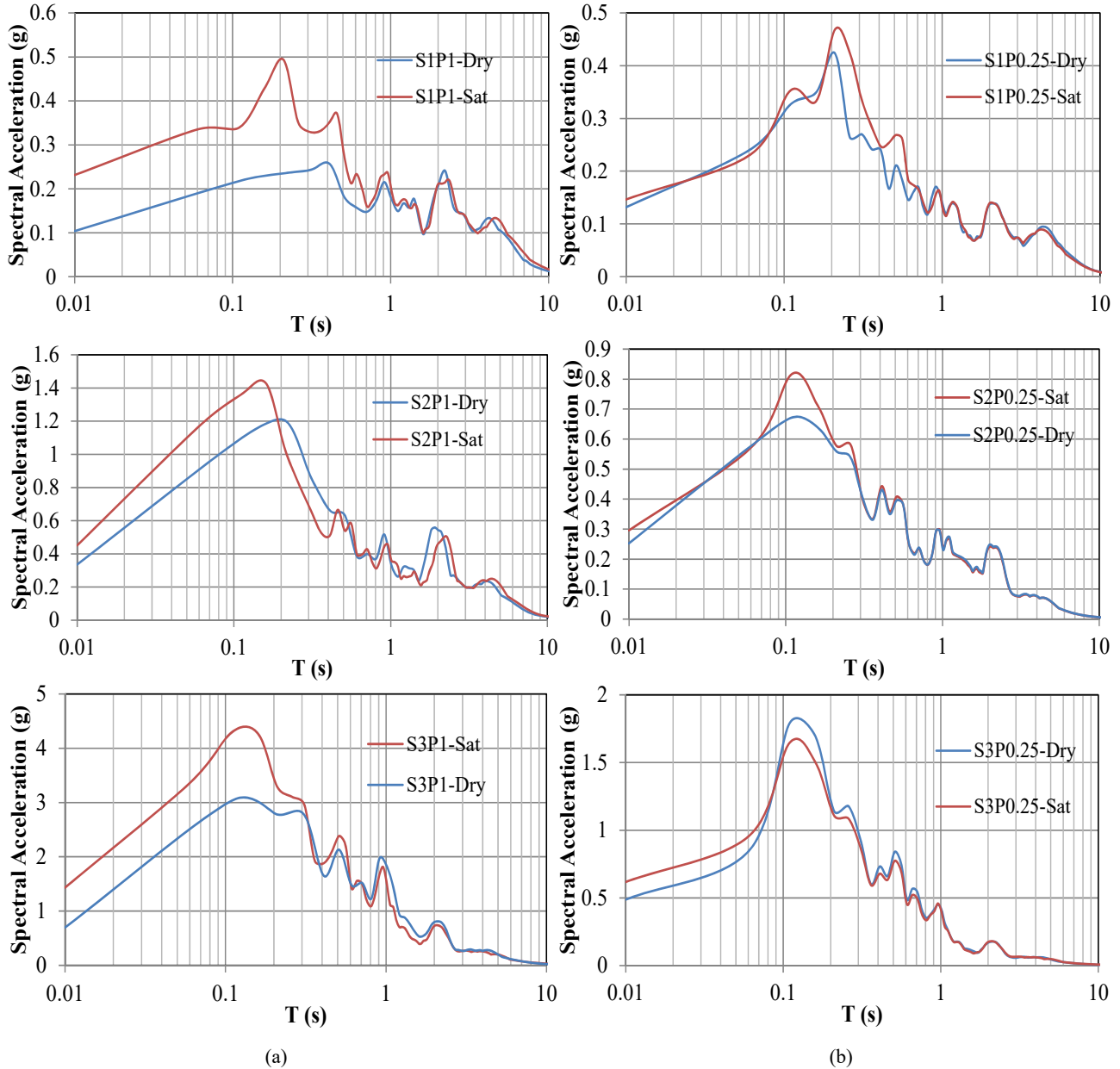

Fig. 9 Comparing the response of different soils in saturated and dry conditions and various PGAs

According to Fig. 9, the difference in $PGA = 0.25g$ is negligible but this difference becomes more conspicuous when increasing PGA. Increased PGA leads to increased strains in soil, and soil will experience a higher level of nonlinear behavior. Also, increased intensity of earthquake will increase the soil pore water pressure which can be a source of increased recorded responses due to reduction of effective stress and soil shear strength.

VI. SUMMARY AND CONCLUSIONS

This paper evaluated the soil-pile interaction under seismic excitation. Sandy soil, stiff clay and soft clay have been studied to cover a wide range of responses in different site conditions. Boulanger et. al. [4] method and dynamic p-y elements have been implemented to model soil-pile interaction. In addition, one-dimensional nonlinear finite element model was developed to analyze the response of soil column at different depths. In the next step, an earthquake

event in accordance with FEMA p695 was used to perform, seismic analysis with two values of PGA.

The results show that saturation of soil increases the response obtained from the pile-soil system and the highest value is related to sandy soils. Also, according to the sensitivity analysis conducted, increased level of PGA makes the difference of responses in dry and saturation conditions more clear, while the increasing percentage is significant in sandy soil. Results of this research show that in the analysis of structures founded on saturated sandy sites, considering the effect of soil-pile interaction can significantly affect the structure's responses.

The results also show that different soils show different behaviors with increased intensity of the earthquake. The greatest increase in response can be observed in soft clay, sand and stiff clay, respectively. This intensification can be attributed to the fact that in sand dynamic compaction occurs with increased intensity of earthquake which makes soil denser, and increases the affecting parameters of maximum shear modulus. In the case of stiff clay, less deformation occurs compared to soft clay, and as expected, both responses and their intensification are lower with increased intensity of earthquakes. In addition, the outputs reveal the effect of inherent hysteresis damping of materials in the intensity of the responses. Given that the hysteresis damping of soft clay is greater than stiff clay, and it is greater in the stiff clay compared to the sand, the response of soft clay has a smaller value.

REFERENCES

- [1] C. Luo, X. Yang, C. Zhan, X. Jin, and Z. Ding, "Nonlinear 3D finite element analysis of soil - pile - structure interaction system subjected to horizontal earthquake excitation," *Soil Dyn. Earthq. Eng.*, vol. 84, pp. 145-156, 2016.
- [2] Y. X. Cai, P. L. Gould, and C. S. Desai, "Nonlinear analysis of 3D seismic interaction of soil-pile-structure systems and application," *Eng. Struct.*, vol. 22, no. 2, pp. 191-199, 2000.
- [3] J. Guin and P. K. Banerjee, "Coupled Soil-Pile-Structure Interaction Analysis under Seismic Excitation," *J. Struct. Eng.*, vol. 124, no. 4, pp. 434-444, Apr. 1998.
- [4] R. W. Boulanger, C. J. Curras, B. L. Kutter, D. W. Wilson, and A. Abghari, "Seismic Soil-Pile-Structure Interaction Experiments and Analyses," *J. Geotech. Geoenvironmental Eng.*, vol. 125, no. 9, pp. 750-759, Sep. 1999.
- [5] J. Penzien, "Seismic Analysis of Platform Structure-Foundation Systems," in *Offshore Technology Conference*, 1975.
- [6] H. G. Poulos, "Analysis of the Settlement of Pile Group," *Geotechnique*, vol. 4, no. 3.
- [7] L. C. Reese, W. Cox, and F. Koop, "Analysis of laterally loaded piles in sand," 6th Annual Offshore Technology Conference, vol. 2. Offshore Technology Conference, pp. 473-484, 08-Apr-1997.
- [8] L. C. Reese and M. W. O. Neill, *Drilled Shafts: Construction Procedures and LRFD Design Methods*, no. 132014. 2010.
- [9] H. Matlock, "Correlations for design of laterally loaded piles in soft clay," *Proc 2nd Annual Offshore Technol Conf*, vol. 1. Offshore Technology Conference, pp. 577-594, 08-Apr-1970.
- [10] M. H. El Naggar and K. J. Bentley, "Dynamic analysis for laterally loaded piles and dynamic p-y curves," *Can. Geotech. J.*, vol. 37, no. 6, pp. 1166-1183, 2000.
- [11] T. Nogami and Y. C. Lam, "Two-Parameter Layer Model for Analysis of Slab on Elastic Foundation," *J. Eng. Mech.*, vol. 113, no. 9, pp. 1279-1291, Sep. 1987.
- [12] T. Kagawa and L. M. Kraft Jr, "Seismic p-y Responses of Flexible Piles," *J. Geotech. Geoenvironmental Eng.*, vol. 106, no. GT8, 1980.
- [13] S. Wang, B. L. Kutter, M. J. Chacko, D. W. Wilson, R. W. Boulanger, and A. Abghari, "Nonlinear seismic soil-pile structure interaction," *Earthq. Spectra*, vol. 14, no. 2, pp. 377-396, May 1998.
- [14] Penzien, Scheffey, and Parmelee, "Seismic Analysis of Bridges on Long Pile," *J. Eng. Mech. Div.*, vol. 90, no. 3, pp. 223-254, 1964.
- [15] H. Matlock, S. FOO, and Bryant, "Simulation of Lateral Pile Behavior Under Earthquake Motion." 1978.
- [16] R. G. Bea, "Earthquake Geotechnology in Offshore Structures," 1991.
- [17] C. J. Curras, R. W. Boulanger, B. L. Kutter, and D. W. Wilson, "Dynamic experiments and analyses of a pile-group-supported structure," *J. Geotech. Geoenvironmental Eng.*, vol. 127, no. 7, p. 585, Jul. 1999.
- [18] P. J. Meymand, "Shaking table scale model tests of nonlinear soil-pile-superstructure interaction in soft clay," *Phd Thesis*, p. 75, 1994.
- [19] E. Rovithis, E. Kirtas, and K. Pitilakis, "Experimental p-y loops for estimating seismic soil-pile interaction," *Bull. Earthq. Eng.*, vol. 7, no. 3, pp. 719-736, Aug. 2009.
- [20] P. B. Schnabel, Lysmer, John, and H. B. Seed, "SHAKE," *UCB/EERC-72/12, Earthq. Eng. Res. Cent.*, vol. 12, pp. 1-92, 1972.
- [21] J. Bardet, K. Ichii, and C. Lin, "EERA - A computer program for Equivalent-linear Earthquake Site Response Analyses of layered soil deposits," *Univ. South. Calif.*, no. August, 2000.
- [22] M. Vucetic and R. Dobry, "Effect of soil plasticity on cyclic response," *J. Geotech. Eng.*, vol. 117, pp. 89-107, 1991.
- [23] D. Bratosin and T. Sireteanu, "Hysteretic damping modelling by nonlinear Kelvin-Voigt model," *Proc. Rom. Acad. Ser. A*, vol. 3, no. 3, pp. 1-6, 2002.
- [24] R. J. LeVeque, *Finite Difference Methods for Ordinary and Partial Differential Equations*. Society for Industrial and Applied Mathematics, 2007.
- [25] H. B. Seed, R. T. Wong, I. M. Idriss, and K. Tokimatsu, "Moduli and Damping Factors for Dynamic Analyses of Cohesionless Soils," *J. Geotech. Eng.*, vol. 112, no. 11, pp. 1016-1032, Nov. 1986.
- [26] Steven L. Kramer, "Geotechnical Earthquake Engineering." Prentice Hall, p. 376, 1996.
- [27] J. Lysmer and Roger L. Kuhlemeyer, "Finite Dynamic Model For Infinite Media," *J. Eng. Mech. Div.*, vol. 95, no. 4, pp. 859-878, 1969.
- [28] W. B. Joyner and A. T. F. Chen, "Calculation of nonlinear ground response in earthquakes," *Bull. Seismol. Soc. Am.*, vol. 65, no. 5, 1975.
- [29] J. H. Prevost, "A simple plasticity theory for frictional cohesionless soils," *Int. J. Soil Dyn. Earthq. Eng.*, vol. 4, no. 1, pp. 9-17, 1985.
- [30] University of California at Berkeley, "Open System for Earthquake Engineering Simulation." (Online). Available: OpenSees.berkeley.edu.
- [31] Z. Yang, A. Elgamal, and E. Parra, "Computational Model for Cyclic Mobility and Associated Shear Deformation," *J. Geotech. Geoenvironmental Eng.*, vol. 129, no. 12, pp. 1119-1127, Dec. 2003.
- [32] Y. M. A. Hashash, S. Dashti, M. I. Romero, M. Ghayoomi, and M. Musgrove, "Evaluation of 1-D seismic site response modeling of sand using centrifuge experiments," *Soil Dyn. Earthq. Eng.*, vol. 78, pp. 19-31, 2015.
- [33] ATC, "Quantification of building seismic performance factors," *Fema*, no. June, p. 421, 2009.