

# Sky Farming: The Alternative Concept of Green Building Using Vertical Landscape Model in Urban Area as an Effort to Achieve Sustainable Development

Nadiah Yola Putri, Nesia Putri Sharfina, Traviata Prakarti

**Abstract**—This paper is a literature review presented descriptively to review the concept of green building to face the challenge of sustainable development and food in urban areas. In this paper, researchers initiated the concept of green building with sky farming method. Sky farming use vertical landscape system in order to realizing food self-sufficient green city. Sky farming relying on plantings and irrigation system efficiency in the building which is adopted the principles of green building. Planting system is done by applying hydroponic plants with *Nutrient Film Technique* (NFT) using energy source of solar cell and grey water from the processing of waste treatment plant. The application of sky farming in urban areas can be a recommendation for the design of environmental-friendly construction. In order to keep the land and distance efficiency, this system is a futuristic idea that would be the connector of human civilization in the future.

**Keywords**—Green building, urban area, sky farming, vertical landscape.

## I. INTRODUCTION

GLOBAL warming has been known as an environmental problem which causes extensive impact to human life. This environmental problem is exacerbated by the increasing of world population. By 2050, it is estimated that 80% of the world's population will grow from 6.8 billion people to 9 billion people will live in urban areas and metropolitan [1]. Population growth will encourage the opening of new land for cultivation. In 2050, it is predicted about 2.5 billion hectares of new land will be opened all over the world with the extent will be equal to 20% of the size of Brazil [2]. The opening of new land will also increase the rate of forest clearing (deforestation) which will accelerate the process of global warming. Real consequences arising from human population growth, especially in urban areas is increasing air pollution implications due to the distribution of food supplies from production sites outside the urban to the urban community

(greater area) significantly from USD 20 billion in 2002 to USD 80 billion in 2007 [3].

Indonesia has the fourth largest population in the world with 237.5 million peoples in 2008 (BPS Indonesia, 2008) [4]. Population in Indonesia has increased exponentially from year to year, this increases should be anticipated with increased demands of food. Population increase should be accompanied with food needs, but what occurred in Indonesia is conversely, the population increased while the land conversion also increased. Based on agricultural census data in the year 1983-2003, a tendency of land conversion on the average of 128,000 hectares per year. However, in recent years, the conversion rate increased significantly. In the year 2007-2010 on the island of Java, the rate of land conversion experience an average of 200,000 per year [5]. In the local context, urban areas with high population in Indonesia including Jakarta, Bogor, Depok, Tangerang, and Bekasi provide new problems in terms of food supply. The high cost on transportation and carbon dioxide emission because of a long-distance distribution have led to losses both from the economic and environmental perspective view. Moreover, the metropolis layout and the planology consideration involving the concept of green building and green environmental are another problem in urban areas. The rate of high air pollution resulting in poor sanitation and health quality. Based on the data from the Indonesian Ministry of Health in 2011, it is noted that 2/3 of the population in Jakarta prone to respiratory illnesses and derivative diseases including stroke [6].

In order to deal with the problems, it requires a new perspective on how to produce food differently from horizontal landscape system that covers the surface of the earth. In this paper, the researchers initiated the concept of green building with sky farming methods. Sky farming is a method of indoor farming applied in the skyscraper. In the implementation, sky farming will rely on system efficiency of planting and irrigation inside the building which adopt the general principle of green building. Green building refers to the structures and using the processes that are environmentally responsible and resource-efficient throughout a building's life cycle [7]. In order to keep the distance and land efficiency, the concept of farming in skyscraper is a futuristic idea that would be the connector of human civilization in the future.

Nadiah Yola Putri is with the Environmental Engineering Department, Faculty of Architecture Landscape and Environmental Technology, Trisakti University (phone: 6282111291109, e-mail: nadiahjolaputri@engineer.com).

Nesia Putri Sharfina is with the Occupational Health and Safety Department, Faculty of Public Health, Indonesia University (e-mail: nesiaputris@gmail.com).

Traviata Prakarti is with the Epidemiology Department, Faculty of Public Health, Indonesia University (e-mail: traviataprakartii@gmail.com).

## II. METHOD

This paper is a literature review presented descriptively to examine the concept of green building in respond to the challenges of sustainable development and food in urban areas. Sky farming is one of the vertical landscape system in order to realize a green city with food self-sufficient.

In sky farming system design will be used two types of system: planting system and irrigation system. In planting system, hydroponic plant will be used, known as Nutrient Film Technique (NFT). In order to flow the nutrients and make plants grow, water flow pump is needed and it comes from water reservoir. In order to activate the pump to drain the water to plants, solar cell as an energy source can be used.

In sky farming system, rainwater and wastewater from the building can be utilized as a water system that will be used for hydroponic plants. The rainwater can be accommodated by gravity system using a reservoir that will be flowed from the top of the building. Whereas, for the wastewater itself can be used a waste treatment plant to process the wastewater itself until it becomes clean water that can be used and reused. The results obtained from these tools are clean water and sediment. The clean water can be flow into the reservoir with the rainwater to be reused later as a sprinkler or an irrigation system for hydroponic plants. All the processed water will be delivered back to the plants to help its growth using the help of pumps.

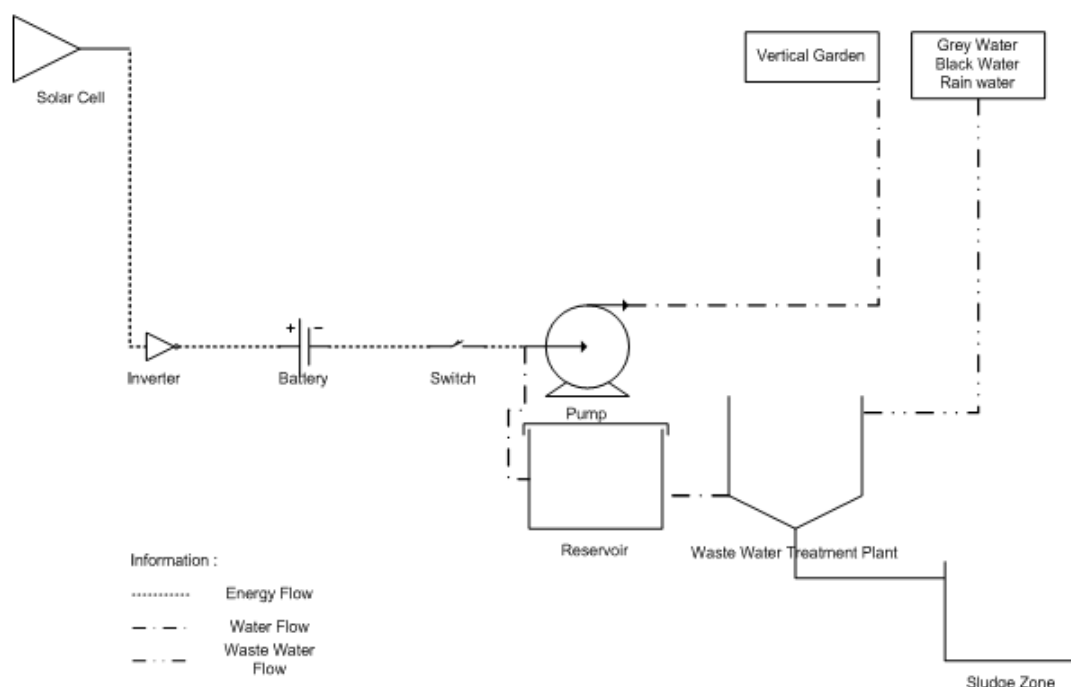

Fig. 1 Diagram Schematic of Vertical Garden Process

## III. RESULT

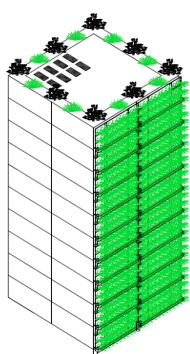

Fig. 2 Application of Vertical Garden

Vertical garden has several benefits, one of them is to lower the temperature around the building about  $\pm 8^{\circ}\text{C}$ . In addition, vertical garden can also reduce the level of noise about 5-10 dB at low frequency, and 2-3.9 dB at high frequency. Vertical

garden can also reduce the air pollution, capture dust particles, and also increase the supply of oxygen [8]. Besides, the concept developed from vertical garden used solar energy captured by solar cell instead of electrical energy to operate the pump to supply the water and plant nutrients, so it can certainly save the operational and maintenance cost of vertical garden. The application of gardening on the rooftop can utilize *Prefabricated Extensive Green (PEG)*.

## IV. DISCUSSION

### A. Green Building Concept

Green building is a concept for a sustainable development which have certain conditions involving the location, planning and design system, renovation and operation, adhere to the principle of energy saving and should have a positive impact on the environment, economic, and social [9]. In implementing the concept, green building prioritize the

efficiency of energy, land, and materials used, also has a solid plan for waste management.

### B. Implementing Sky Farming Methods on Green Building

Sky farming is an application method of green building. This method is an alternative concept for an efficient and strategic crop production, which is related to the minimization of resource use per unit produced [10]. Several things to consider in green building concept is as follows:

#### 1. Efficient Use of Energy

Architecture is one of the most influential consideration during the implementation of sustainable architecture, because of its impact directly on the land. A design concept that can minimize the use of electrical energy, for example, can be classified as sustainable concepts in energy, which can be integrated with the concept of the use of source of maximum sunlight for lighting, natural conditioning, heating water for domestic needs, etc.

#### 2. Efficient Use of Land

Narrower and more expensive land should not be used entirely to build a building, thus it is better to keep some green areas and supporting sustainable land. The potential of green plants in the soil can be replaced or maximized with a variety of innovations, such as the manufacture of roof above the building (roof garden), the hanging gardens (with hanging pots of plants on the surrounding buildings), hedgerow, or wall with garden on it.

#### 3. Efficient Use of Materials

The efficient use of materials can be done with utilizing the potential of renewable energy such as wind, sunlight, and water energy to generate domestic electrical energy for household and other buildings independently. Advancement in technology may open possibilities of new materials that is open to innovation and inexpensive.

#### 4. In the Waste Management

It is done by making domestic wastewater treatment systems such as sewage (black water, gray water) independently and do not overload the city's water flow system. The detail of sky farming system design proposed are as follows:

### C. Planting System

The increasing scarcity of land resources, especially due to the development of industry and services sectors led to conventional agricultural activities increasingly uncompetitive because of the high price of land. The agricultural cultivation technology of hydroponic system provides an alternative for farmers who have a narrow field, especially in urban areas where there is no location found for cultivation.

Planting system presented in this paper uses a hydroponic system where the planting is done by using the media of water without soil. The advantages of hydroponic cultivation system includes: (1) the density of plants per unit area can be multiplied thus saving the land use; (2) the quality of the product (shape, size, flavor, color, sanitation / hygiene) can be

guaranteed due to the needs of plant nutrients supplied in a controlled manner inside the greenhouse; (3) does not depend on the season / time of planting and harvesting can be adjusted in accordance with market needs.

Hydroponic type that used in the sky farming concept in urban building is Nutrient Film Technique (NFT). NFT system apply a constant nutrient flow (with water and air), so it does not require a timer in its application. NFT works by flowing the nutrient solution that pumped from the reservoir continuously into the growing tray (usually made from PVC pipe). The nutrient solution which has passed through roots will be back to the reservoir, and the cycle repeated [11].

NFT system depends on electricity. The loss of power or pump damage can cause the roots to dry out quickly. Therefore, in order to fulfill energy needs, the sky farming concept utilize all types of energy that can be exploited to reduce consumption. In order to flow the nutrients and make plants grow, water flow pump is needed and it comes from water reservoir. In order to activate the pump to drain the water to plants, solar cell as an energy source can be used.

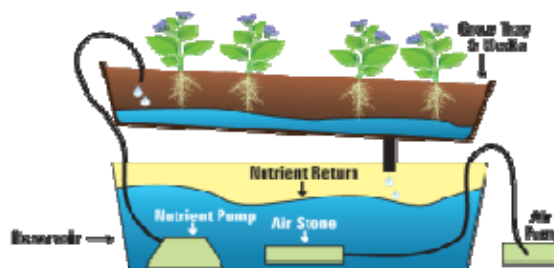

Fig. 3 Nutrient Film Technique (NFT)

### D. Irrigation System

Irrigation system on sky farming concept has less energy characteristics due to the irrigation system that do not use pumps, but rather utilizing the force of gravity in flowing the water where on the roof of the building must be installed a capturing rainwater tool to capture rainwater [12]. Water is an important factor in the growth and the progress of plants. In order to maximize the use of water in the building, the irrigating process of cycle farming plant will be given of the processing result water from processing of rain, building, and black water which is processed to standardize the Environmental Quality Standard for the use in watering plants accordance to Government Regulation number 82 year 2001.

In order to achieve the quality standard, the rain water coming from catchment will be included in the filtration processing unit, recycle tub, then distributed to the sky farming drains. Black water and grey water will be mixed and processed in waste treatment plant. The results obtained from these tools are clean water and sediment. The clean water can be flow into the reservoir with the rainwater to be reused later as a sprinkler or an irrigation system for hydroponic plants. All the processed water will be delivered back to the plants to help its growth using the help of pumps.

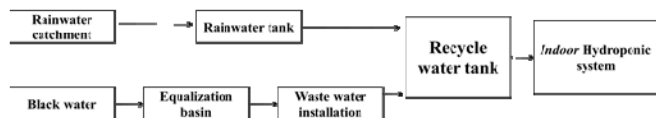

Fig. 4 Waste Treatment Plant

### E. The Benefits of Vertical Farming Model

The concept of indoor farming in skyscrapers have goals and benefits as follows:

1. The supply of foodstuffs to urban areas will be sustainable and not seasonal,
2. Reduce the possibility of crop failures caused by disasters such as floods and droughts,
3. Balancing the ecosystem by reducing the amount of horizontal land cleared for farming,
4. Reducing carbon dioxide emission as a pollutant in foodstuffs transport which requires a long distance distribution from agriculture to urban locations,
5. Reduce the cost of food production,
6. Applying the concept of green building which still very rare in the urban area.

### V. CONCLUSION

The concept of green building with sky farming method is an alternative concept to answer the challenge of sustainability in land and food in urban areas. Vertical farm or vertical landscape is a farm concept which demonstrated in skyscrapers that are environmentally friendly. This concept is shown as a futuristic design by relying on the optimization of planting and irrigation systems. The application of sky farming in urban areas is expected to be a recommendation for the design of environmentally friendly building construction by utilizing the efficiency of energy, land, and materials, and also waste management so that a green city with food self-sufficient will realized. Multi-variant user technology is required to be explored further so that it can be implemented in a systematic project management and well worth the investment.

### REFERENCES

- [1] United Nations Statistics Division (Internet). United States: United Nations; 2014 (cited 2015 April 25). Available from: <http://unstats.un.org/unsd/demographic/default.htm>
- [2] Food and Agriculture Organization of the United Nations (Internet) Rome: FAO; 2011 (cited 2015 April 24). Available from: <http://www.fao.org/docrep/015/i2307e/i2307e.pdf>
- [3] Nellemann, C., Henriksen, R., Raxier, P., Ash, N., Mrema, E. (Eds). The Environmental Crime Crisis – Threats to Sustainable Development from Illegal Exploitation and Trade in Wildlife and Forest Resources (Internet). (Place unknown): UNEP; 2011 (cited 2015 Apr 20). Available from: <http://www.unep.org/unea/docs/racrimccrisis.pdf>
- [4] Central Bureau of Statistics Indonesia (Internet). Jakarta: Statistics Indonesia Association; 2010 (cited 2015 April 23). Available from: <http://www.bps.go.id/linkTabelStatis/view/id/1267>
- [5] Ardita Rizky P.A. The function of social media as Cycle Farming Branding on Vertical Farming Model (Internet). 2015 Feb 01 (cited 2015 Apr 23). Available from Indonesia Newsstand: <http://m.kompasiana.com/post/read/720705/1/peran-media-dalam-branding-cycle-farming-strategi-integrasi-model-pertanian-vertikal-dengan-konsep-green-building-sebagai-solusi-pemanfaatan-lahan-basis-modal-usaha-dari-ekonomi-kreatif.html>

- [6] Research and Development Health Division (Internet). Jakarta: Ministry of Health Republic of Indonesia; 2010 (cited 2015 April 23). Available from: <http://www.depkes.go.id/resources/download/general/Hasi%20Risksedas%202013.pdf>
- [7] Ian Douglas, Philip James. Urban Ecology: An Introduction (Internet). Routledge; 2014 (cited 2015 Apr 22) Available from google books: [https://books.google.co.id/books?id=jBohBQAAQBAJ&dq=Prefabricated+Extensive+Green+\(PEG\).&hl=id&source=gbs\\_navlinks\\_s](https://books.google.co.id/books?id=jBohBQAAQBAJ&dq=Prefabricated+Extensive+Green+(PEG).&hl=id&source=gbs_navlinks_s)
- [8] Suryandari, Danusastro, The Role of Research and Improvement Skills of Landscape Architects in Facing the Implementation of Green Building Concept. Vol. 3 No. 2. Jakarta: Journal of Indonesian Landscape; 2011.
- [9] Sudarwani. The Application of Green Architecture and Green Building as an Effort to Reach Sustainable Architecture. Faculty of Engineering Pandanaran University. Jakarta; 2002.
- [10] Germer, Jorn, editor. Skyfarming an Ecological Innovation to Enhance Global Food Security. United States: Journal of Consumer Protection and Food Safety; 2002.
- [11] Department of Agriculture (Internet). Asia: Ministry of Agriculture; 2011 (cited 2015 April 23). Available from: [http://ruaf-asia.iwmi.org/Data/Sites/6/PDFs/H\\_Eng.pdf](http://ruaf-asia.iwmi.org/Data/Sites/6/PDFs/H_Eng.pdf)
- [12] Prayong K. Efficiency of Wastewater Treatment with Hydroponics. ARPN Journal of Agricultural and Biological Science (Internet). 2013 December (cited 2015 Apr 22); Vol.08, no.12: (about 6 pp.) Available from: [http://www.arpnjournals.com/jabs/research\\_papers/tp\\_2013/jabs\\_1213\\_625.pdf](http://www.arpnjournals.com/jabs/research_papers/tp_2013/jabs_1213_625.pdf)